



FAN2108 — TinyBuck™ 3-24 V Input, 8 A, High-Efficiency, Integrated Synchronous Buck Regulator

Features

- Wide Input Voltage Range: 3 V-24 V
- Wide Output Voltage Range: 0.8 V to 80% V_{IN}
- 8 A Output Current
- Programmable Frequency Operation: 200 KHz to 600 KHz
- Over 95% Peak Efficiency
- Integrated Schottky Diode on Low-side MOSFET Boosts Efficiency
- Internal Bootstrap diode
- Power-Good Signal
- Pre-Bias Startup
- Accepts Ceramic Capacitors on Output
- External Compensation for Flexible Design
- Input Under-Voltage Lockout
- Programmable Current Limit
- Under-Voltage, Over-Voltage, and Thermal Shutdown Protections
- Internal Soft-Start
- 5 x 6 mm, 25-Pin, 3-Pad MLP Package

Applications

- Servers
- Point-of-Load Regulation
- High-End Computing Systems
- Graphics Cards
- Battery-Powered Equipment
- Set-Top Boxes

Description

The FAN2108 TinyBuck™ is a highly efficient, small footprint, 8 A, synchronous buck regulator.

The FAN2108 contains both synchronous MOSFETs and a controller/driver with optimized interconnects in one package, which enables designers to solve high-current requirements in a small area with minimal external components.

External compensation, programmable switching frequency, and current limit features allow design optimization and flexibility.

The summing current mode modulator uses lossless current sensing for current feedback and over-current protection. Voltage feedforward helps operation over a wide input voltage range.

Fairchild's advanced BiCMOS power process, combined with low- $R_{DS(ON)}$ internal MOSFETs and a thermally efficient MLP package, provide the ability to dissipate high power in a small package.

Output over-voltage, under-voltage, and thermal shutdown protections help protect the device from damage during fault conditions. FAN2108 prevents pre-biased output discharge during startup in point-of-load applications.

Related Application Notes

[AN-8022 — TinyCalc™ Calculator](#)

Ordering Information

Part Number	Operating Temperature Range	Package	Packing Method
FAN2108MPX	-10°C to 85°C	Molded Leadless Package (MLP) 5 x 6 mm	Tape and Reel
FAN2108EMPX	-40°C to 85°C		

Typical Application

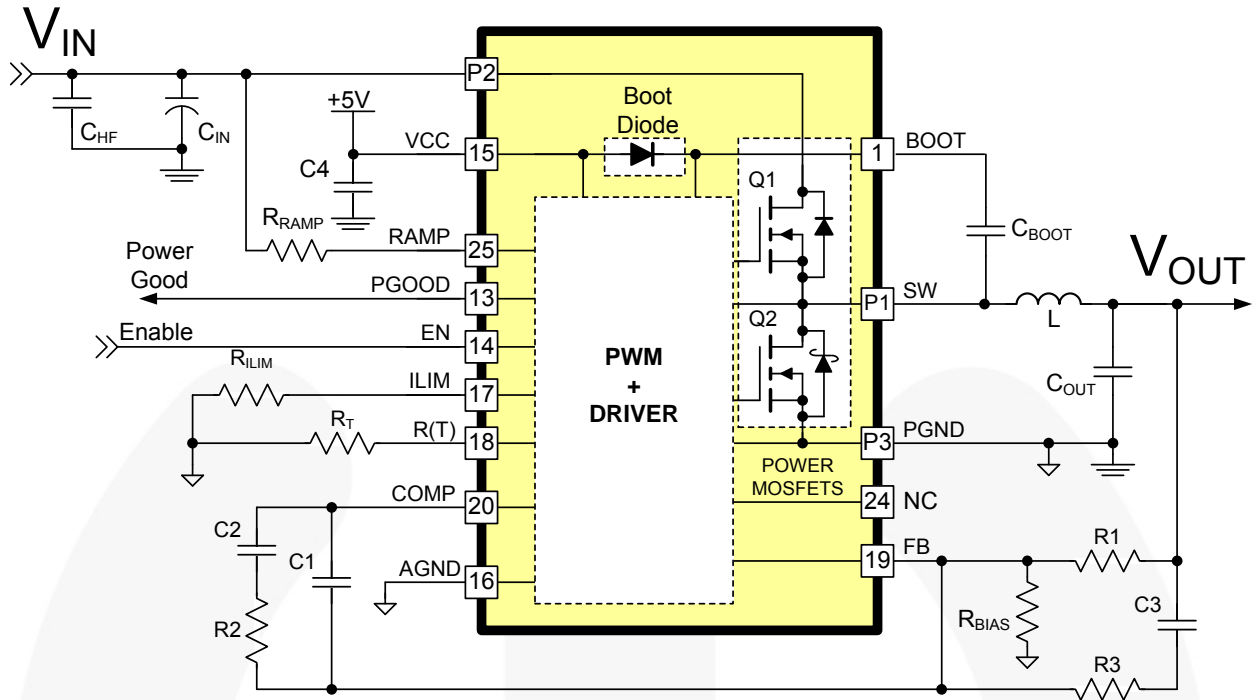

Figure 1. Typical Application Diagram

Block Diagram

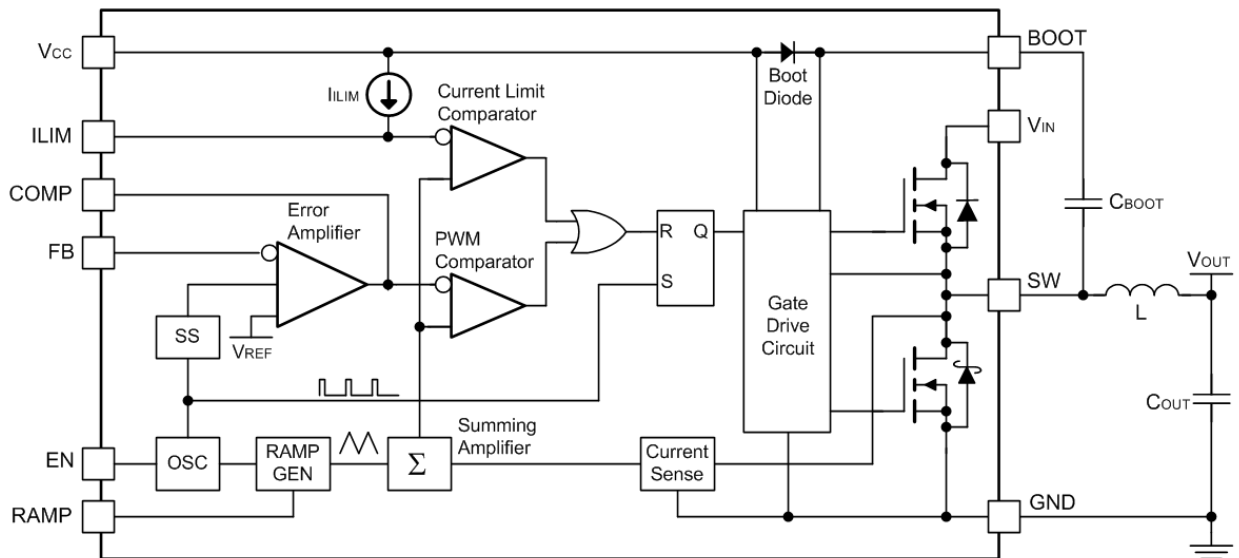

Figure 2. Block Diagram

Pin Configuration

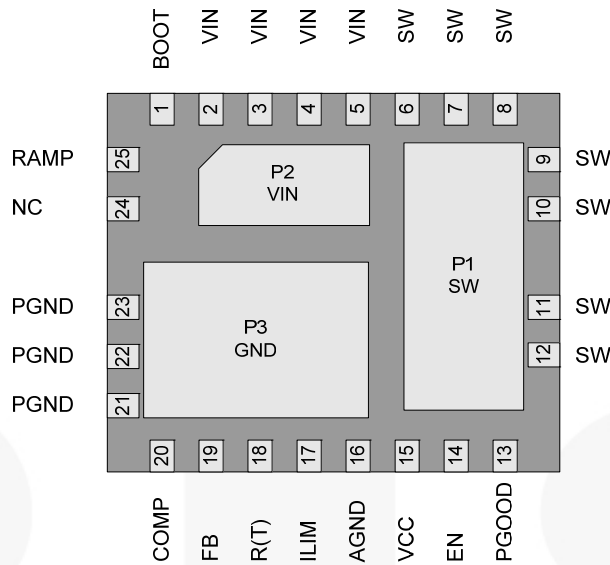

Figure 3. MLP 5 x 6 mm Pin Configuration (Bottom View)

Pin Definitions

Pin #	Name	Description
P1, 6-12	SW	Switching Node.
P2, 2-5	VIN	Power Input Voltage. Connect to the main input power source.
P3, 21-23	PGND	Power Ground. Power return and Q2 source.
1	BOOT	High-Side Drive BOOT Voltage. Connect through capacitor (C_{BOOT}) to SW. The IC includes an internal synchronous bootstrap diode to recharge the capacitor on this pin to V_{CC} when SW is LOW.
13	PGOOD	Power-Good Flag. An open-drain output that pulls LOW when FB is outside a $\pm 10\%$ range of the reference. PGOOD does not assert HIGH until the fault latch is enabled.
14	EN	ENABLE. Enables operation when pulled to logic HIGH or left open. Toggling EN resets the regulator after a latched fault condition. This input has an internal pull-up when the IC is functioning normally. When a latched fault occurs, EN is discharged by a current sink.
15	VCC	Input Bias Supply for IC. The IC's logic and analog circuitry are powered from this pin.
16	AGND	Analog Ground. The signal ground for the IC. All internal control voltages are referred to this pin. Tie this pin to the ground island/plane through the lowest impedance connection.
17	ILIM	Current Limit. A resistor (R_{ILIM}) from this pin to AGND can be used to program the current-limit trip threshold lower than the default setting.
18	R(T)	Oscillator Frequency. A resistor (R_T) from this pin to AGND sets the PWM switching frequency.
19	FB	Output Voltage Feedback. Connect through a resistor divider to the output voltage.
20	COMP	Compensation. Error amplifier output. Connect the external compensation network between this pin and FB.
24	NC	No Connect. This pin is not used.
25	RAMP	Ramp Amplitude. A resistor (R_{RAMP}) connected from this pin to V_{IN} sets the ramp amplitude and provides voltage feedforward functionality.

Absolute Maximum Ratings

Stresses exceeding the absolute maximum ratings may damage the device. The device may not function or be operable above the recommended operating conditions and stressing the parts to these levels is not recommended. In addition, extended exposure to stresses above the recommended operating conditions may affect device reliability. The absolute maximum ratings are stress ratings only.

Parameter	Conditions	Min.	Max.	Unit
V _{IN} to PGND			28	V
V _{CC} to AGND	AGND=PGND		6	V
BOOT to PGND			35	V
BOOT to SW		-0.3	6.0	V
SW to PGND	Continuous	-0.5	24.0	V
	Transient (t < 20 ns, f ≤ 600 KHz)	-5	30	V
All other pins		-0.3	V _{CC} +0.3	V
ESD	Human Body Model, JEDEC JESD22-A114	2		kV
	Charged Device Model, JEDEC JESD22-C101	2.5		

Recommended Operating Conditions

The Recommended Operating Conditions table defines the conditions for actual device operation. Recommended operating conditions are specified to ensure optimal performance to the datasheet specifications. Fairchild does not recommend exceeding them or designing to absolute maximum ratings.

Symbol	Parameter	Conditions	Min.	Typ.	Max.	Unit
V _{CC}	Bias Voltage	V _{CC} to AGND	4.5	5.0	5.5	V
V _{IN}	Supply Voltage	V _{IN} to PGND	3		24	V
T _A	Ambient Temperature	FAN2108MPX	-10		+85	°C
		FAN2108EMPX	-40		+85	°C
T _J	Junction Temperature				+125	°C
f	Switching Frequency				600	kHz

Thermal Information

Symbol	Parameter	Min.	Typ.	Max.	Unit
T _{STG}	Storage Temperature	-65		+150	°C
T _L	Lead Soldering Temperature, 10 Seconds			+300	°C
T _{VP}	Vapor Phase, 60 Seconds			+215	°C
T _I	Infrared, 15 Seconds			+220	°C
θ _{JC}	Thermal Resistance: Junction-to-Case	P1 (Q2)	4		°C/W
		P2 (Q1)	7		°C/W
		P3	4		°C/W
θ _{J-PCB}	Thermal Resistance: Junction-to-Mounting Surface ⁽¹⁾		35		°C/W
P _D	Power Dissipation, T _A =25°C ⁽¹⁾			2.8	W

Note:

1. Typical thermal resistance when mounted on a four-layer, two-ounce PCB, as shown in Figure 25. Actual results are dependent on mounting method and surface related to the design.

Electrical Specifications

Electrical specifications are the result of using the circuit shown in Figure 1 unless otherwise noted.

Symbol	Parameter	Conditions	Min.	Typ.	Max.	Unit
Power Supplies						
I_{CC}	V_{CC} Current	SW=Open, FB=0.7 V, V_{CC} =5 V, f_{SW} =600 KHz		8	12	mA
		Shutdown: EN=0, V_{CC} =5 V		7	10	μ A
V_{UVLO}	V_{CC} UVLO Threshold	Rising V_{CC}	4.1	4.3	4.5	V
		Hysteresis		300		mV
Oscillator						
f	Frequency	R_T =50 K Ω	255	300	345	KHz
		R_T =24 K Ω	540	600	660	KHz
t_{ON}	Minimum On-Time ⁽²⁾			50	65	ns
V_{RAMP}	Ramp Amplitude, peak-to-peak	16 V_{IN} , 1.8 V_{OUT} , R_T =30 K Ω , R_{RAMP} =200 K Ω		0.53		V
t_{OFF}	Minimum Off-Time ⁽²⁾			100	150	ns
Reference						
V_{FB}	Reference Voltage (see Figure 4 for Temperature Coefficient)	FAN2108MPX, 25°C	794	800	806	mV
		FAN2108EMPX, 25°C	795	800	805	mV
Error Amplifier						
G	DC Gain ⁽²⁾		80	85		dB
BW	Gain Bandwidth Product ⁽²⁾	V_{CC} =5 V	12	15		MHz
V_{COMP}	Output Voltage		0.4		3.2	V
I_{SINK}	Output Current, Sourcing	V_{CC} =5 V, V_{COMP} =2.2 V	1.5	2.2		mA
I_{SOURCE}	Output Current, Sinking	V_{CC} =5 V, V_{COMP} =1.2 V	0.8	1.2		mA
I_{BIAS}	FB Bias Current	V_{FB} =0.8 V, 25°C	-850	-650	-450	nA
Protection and Shutdown						
I_{LIM}	Current Limit	R_{LIM} Open at 25°C (see Circuit Description)	12	15	18	A
I_{LIM}	I_{LIM} Current		-11	-10	-9	μ A
T_{TSD}	Over-Temperature Shutdown	Internal IC Temperature		+155		°C
T_{HYS}	Over-Temperature Hysteresis			+30		°C
V_{OVP}	Over-Voltage Threshold	Two Consecutive Clock Cycles	110	115	121	% V_{OUT}
V_{UVLO}	Under-Voltage Shutdown	16 Consecutive Clock Cycles	68	73	78	% V_{OUT}
V_{FLT}	Fault Discharge Threshold	Measured at FB Pin		250		mV
V_{FLT_HYS}	Fault Discharge Hysteresis	Measured at FB Pin (V_{FB} ~500 mV)		250		mV
Soft-Start						
t_{SS}	V_{OUT} to Regulation (T0.8)	Frequency=600 KHz		5.3		ms
t_{EN}	Fault Enable/SSOK (T1.0)			6.7		ms

Note:

- Specifications guaranteed by design and characterization; not production tested.

Electrical Specifications (Continued)

Recommended operating conditions are the result of using the circuit shown in Figure 1 unless otherwise noted.

Symbol	Parameter	Conditions	Min.	Typ.	Max.	Unit
Control Functions						
V_{EN_R}	EN Threshold, Rising			1.35	2.00	V
V_{EN_HYS}	EN Hysteresis			250		mV
R_{EN}	EN Pull-Up Resistance			800		K Ω
I_{EN}	EN Discharge Current	Auto-Restart Mode		1		μ A
R_{FB}	FB OK Drive Resistance				800	Ω
V_{PG}	PGOOD Threshold	$FB < V_{REF}$	-14	-11	-8	% V_{REF}
		$FB > V_{REF}$	+7	+10	+13.5	
V_{PG_L}	PGOOD Output Low	$I_{OUT} \leq 2$ mA			0.4	V

Typical Characteristics

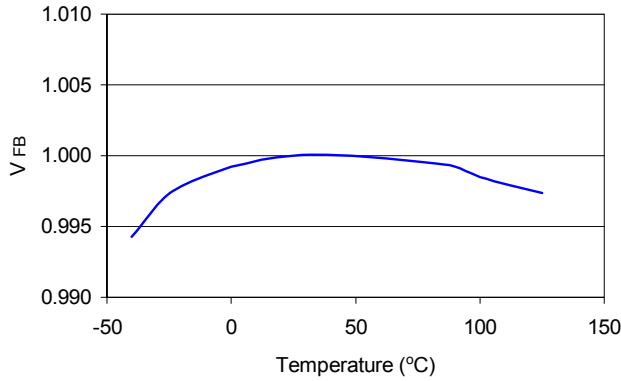

Figure 4. Reference Voltage (V_{FB}) vs. Temperature, Normalized

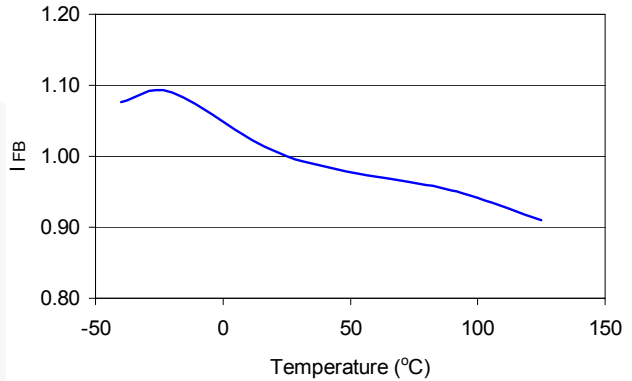

Figure 5. Reference Bias Current (I_{FB}) vs. Temperature, Normalized

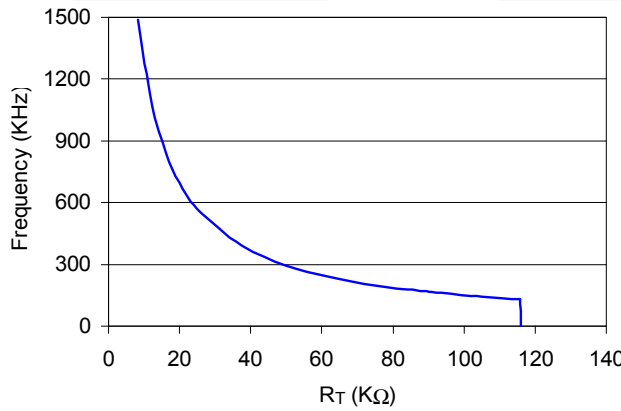

Figure 6. Frequency vs. R_T

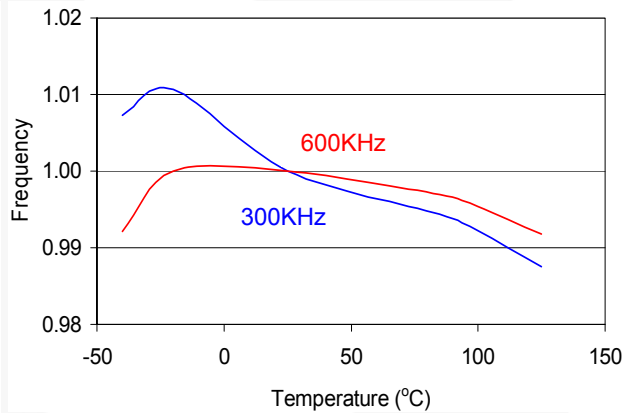

Figure 7. Frequency vs. Temperature, Normalized

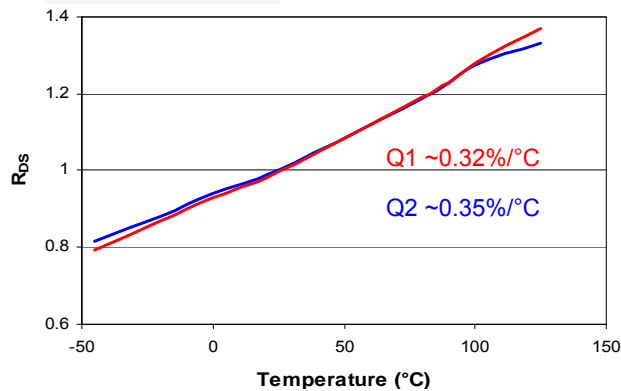

Figure 8. R_{DS} vs. Temperature, Normalized ($V_{CC}=V_{GS}=5V$)

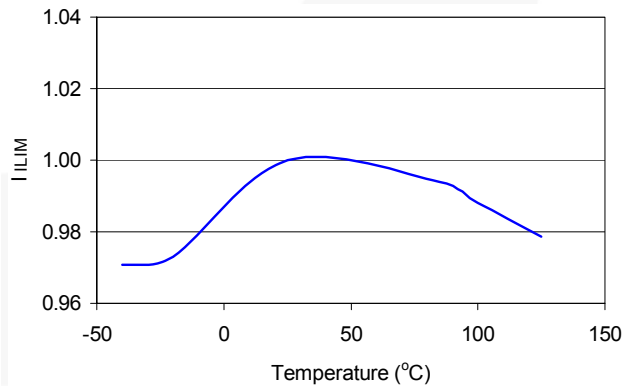

Figure 9. I_{LIM} Current (I_{LIM}) vs. Temperature, Normalized

Application Circuit

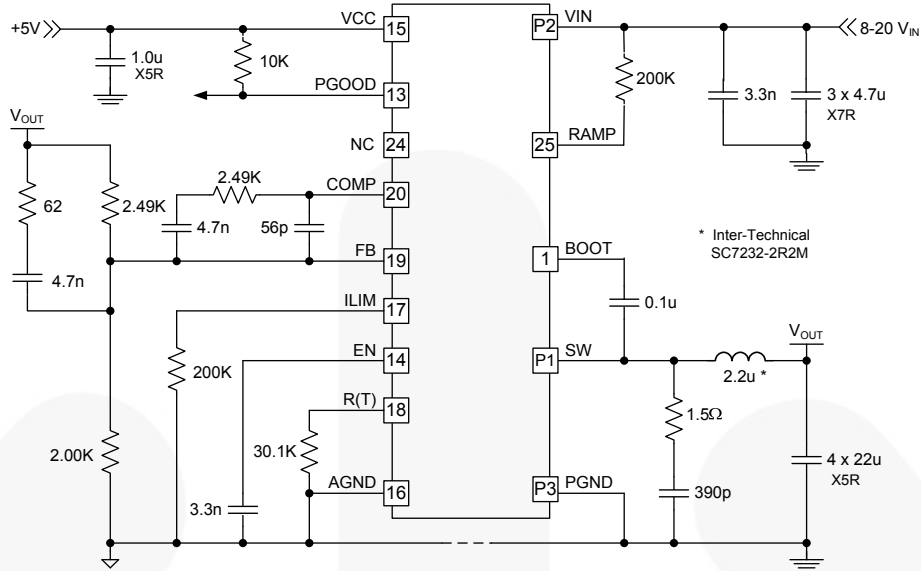

Figure 10. Application Circuit: 1.8 V_{OUT}, 500 KHz

Typical Performance Characteristics

Typical operating characteristics using the circuit shown in Figure 10. V_{IN}=12 V, V_{CC}=5 V, unless otherwise specified.

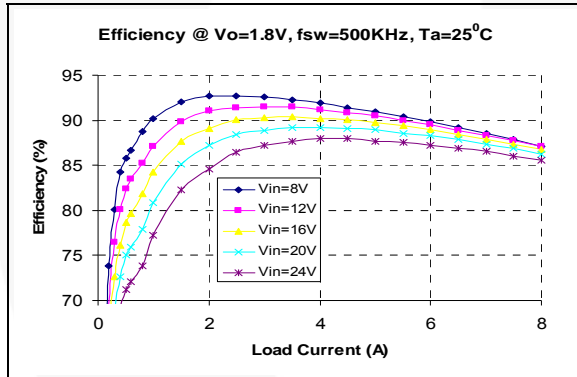

Figure 11. 1.8 V_{OUT} Efficiency Over V_{IN} vs. Load

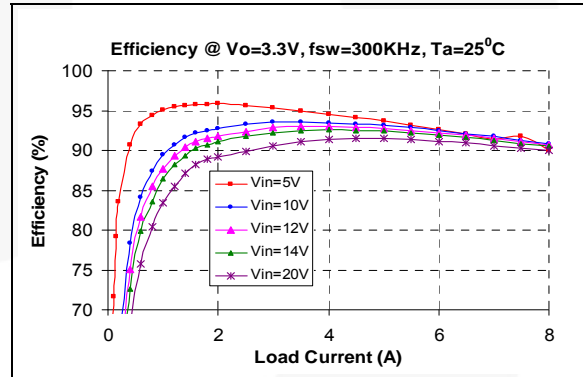

Figure 12. 3.3 V_{OUT} Efficiency Over V_{IN} vs. Load

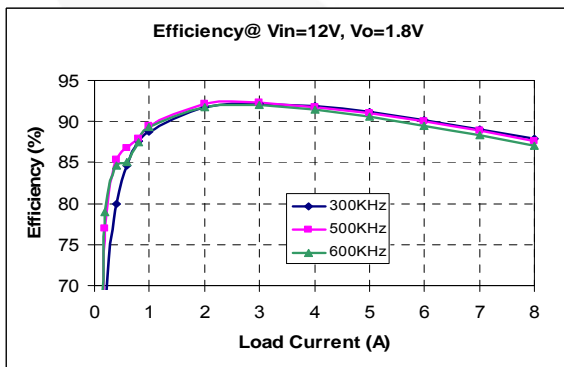

Figure 13. 1.8 V_{OUT} Efficiency Over Frequency vs. Load

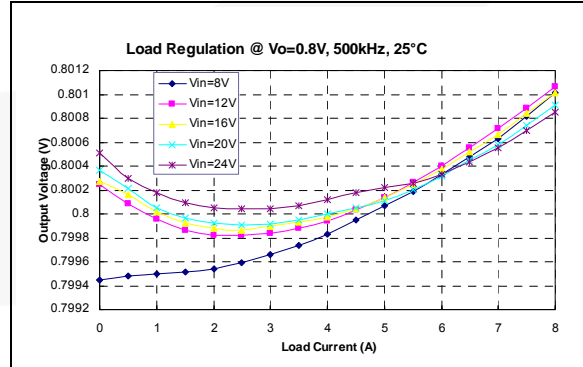

Figure 14. 0.8 V_{OUT} Load Regulation Over V_{IN} vs. Load

Typical Performance Characteristics (Continued)

Typical operating characteristics using the circuit shown in Figure 10. $V_{IN}=12\text{ V}$, $V_{CC}=5\text{ V}$, unless otherwise specified.

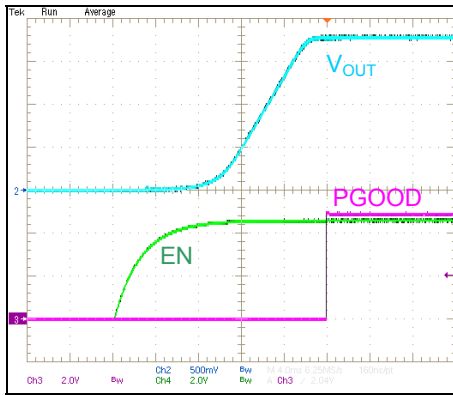

Figure 15. Startup, 3 A Load

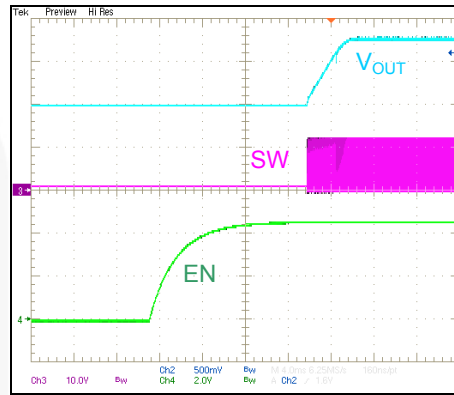

Figure 16. Startup with 1 V Pre-Bias on V_{OUT}

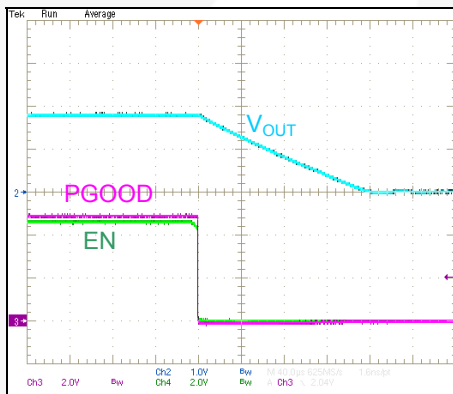

Figure 17. Shutdown, 1 A Load

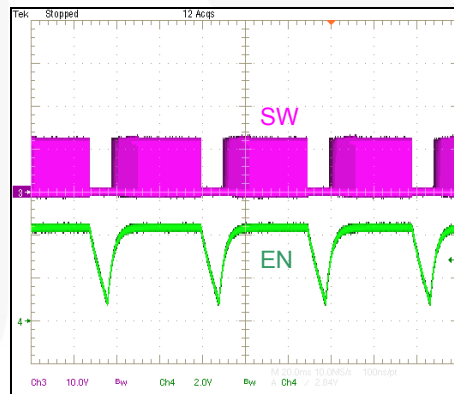

Figure 18. Restart on Fault

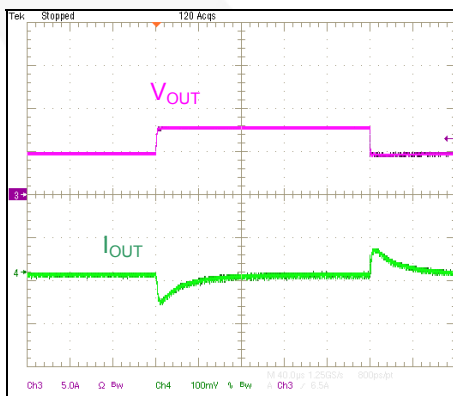

Figure 19. Transient Response, 2-8 A Load

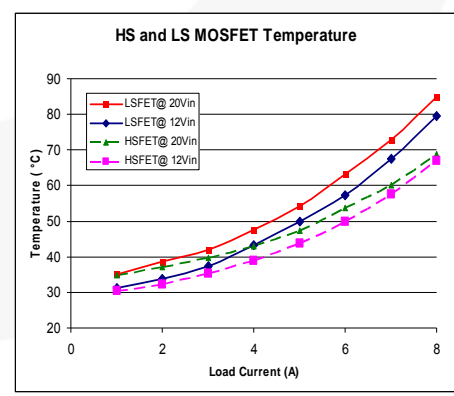

Figure 20. MOSFET Temperature – Still Air at Room Temperature

Circuit Description

Initialization

Once V_{CC} exceeds the UVLO threshold and EN is HIGH, the IC checks for an open or shorted FB pin before releasing the internal soft-start ramp (SS).

If R1 is open (Figure 1), the error amplifier output (COMP) is forced LOW and no pulses are generated. After the SS ramp times out (T1.0), an under-voltage latched fault occurs.

If the parallel combination of R1 and R_{BIAS} is $\leq 1\text{ K}\Omega$, the internal SS ramp is not released and the regulator does not start.

Bias Supply

The FAN2108 requires a 5 V supply rail to bias the IC and provide gate-drive energy. Connect a $\geq 1.0\ \mu\text{f}$ X5R or X7R decoupling capacitor between VCC and PGND.

Since V_{CC} is used to drive the internal MOSFET gates, supply current is frequency and voltage dependent. Approximate V_{CC} current (I_{CC}) is calculated by:

$$I_{CC(mA)} = 4.58 + \left[\left(\frac{V_{CC} - 5}{227} + 0.013 \right) \cdot (f - 128) \right] \quad (1)$$

where frequency (f) is expressed in KHz.

Enable

FAN2108 has an internal pull-up to enable pin so that the IC is enabled once V_{CC} is applied. Connecting a small capacitor across EN and AGND delays the rate of voltage rise on the EN pin. EN pin also serves for the restart whenever a fault occurs (refer to the Auto-Restart section). For applications where sequencing is required, FAN2108 can be enabled (after the V_{CC} comes up) with external control, as shown in Figure 20.

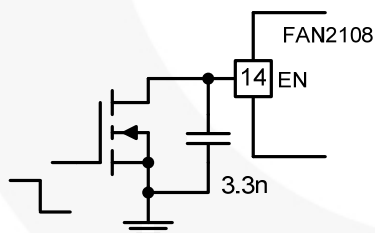

Figure 20. Enabling with External Control

Setting the Frequency

Oscillator frequency is determined by an external resistor, R_T , connected between the R(T) pin and AGND. Resistance is calculated by:

$$R_{T(K\Omega)} = \frac{(10^6 / f) - 135}{65} \quad (2)$$

where R_T is in $K\Omega$ and frequency (f) is in KHz.

The regulator cannot start if R_T is left open.

Soft-Start

Once internal SS ramp has charged to 0.8 V (T0.8), the output voltage is in regulation. Until SS ramp reaches 1.0 V (T1.0), the fault latch is inhibited.

To avoid skipping the soft-start cycle, it is necessary to apply V_{IN} before V_{CC} reaches its UVLO threshold.

Soft-start time is a function of oscillator frequency.

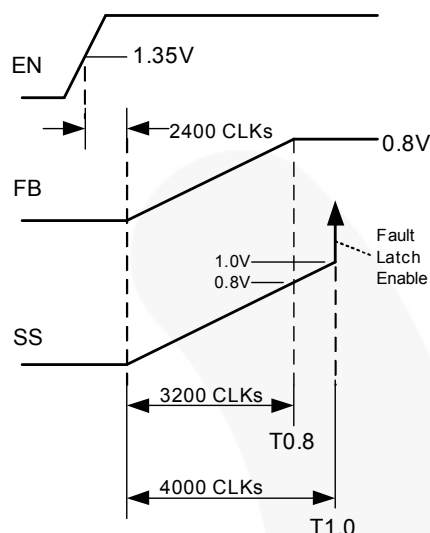

Figure 21. Soft-Start Timing Diagram

The regulator does not allow the low-side MOSFET to operate in full synchronous rectification mode until internal SS ramp reaches 95% of V_{REF} (~0.76 V). This helps the regulator to start on a pre-biased output and ensures that inductor current does not "ratchet" up during the soft-start cycle.

V_{CC} UVLO or toggling the EN pin discharges the SS and resets the IC.

Setting the Output Voltage

The output voltage of the regulator can be set from 0.8 V to 80% of V_{IN} by an external resistor divider ($R1$ and R_{BIAS} in Figure 1).

The internal reference is 0.8 V with 650 nA, sourced from the FB pin to ensure that, if the pin is open, the regulator does not start.

The external resistor divider is calculated using:

$$\frac{0.8V}{R_{BIAS}} = \frac{V_{OUT} - 0.8V}{R1} + 650nA \quad (3)$$

Connect R_{BIAS} between FB and AGND.

Calculating the Inductor Value

Typically the inductor is set for a ripple current (ΔI_L) of 10% to 35% of the maximum DC load. Regulators requiring fast transient response use a value on the high side of this range; while regulators that require very low output ripple and/or use high-ESR capacitors restrict allowable ripple current.

$$L = \frac{V_{OUT} \cdot (1 - \frac{V_{OUT}}{V_{IN}})}{\Delta I_L \cdot f} \quad (4)$$

where f is the oscillator frequency.

Setting the Ramp Resistor Value

The internal ramp voltage excursion (ΔV_{RAMP}) during t_{ON} should be set to 0.6 V at nominal operating point. R_{RAMP} is approximately:

$$R_{RAMP(k\Omega)} = \frac{(V_{IN} - 1.8) \cdot V_{OUT}}{18 \times 10^{-6} \cdot V_{IN} \cdot f} - 2 \quad (5)$$

where frequency (f) is expressed in KHz.

Setting the Current Limit

The current limit system involves two comparators. The MAX I_{LIMIT} comparator is used with a V_{ILIM} fixed-voltage reference and represents the maximum current limit allowable. This reference voltage is temperature compensated to reflect the R_{DSON} variation of the low-side MOSFET. The ADJUST I_{LIMIT} comparator is used where the current limit needs to be set lower than the V_{ILIM} fixed reference. The 10 μA current source does not track the R_{DSON} changes over temperature, so change is added into the equations for calculating the ADJUST I_{LIMIT} comparator reference voltage, as is shown below. Figure 22 shows a simplified schematic of the over-current system.

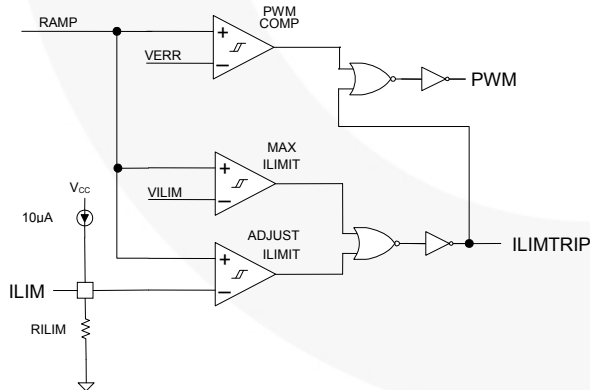

Figure 22. Current-Limit System Schematic

Since the I_{LIM} voltage is set by a 10 μA current source into the R_{ILIM} resistor, the basic equation for setting the reference voltage is:

$$V_{RILIM} = 10\mu A \cdot R_{ILIM} \quad (6)$$

To calculate R_{ILIM} :

$$R_{ILIM} = V_{RILIM} / 10\mu A \quad (7)$$

The voltage V_{RILIM} is made up of two components, V_{BOT} (which relates to the current through the low-side MOSFET) and V_{RMPEAK} (which relates to the peak current through the inductor). Combining those two voltage terms results in:

$$R_{ILIM} = (V_{BOT} + V_{RMPEAK}) / 10\mu A \quad (8)$$

$$R_{ILIM} = \{0.96 + (I_{LOAD} \cdot R_{DSON} \cdot K_T \cdot 8)\} + \{D \cdot (V_{IN} - 1.8) / (f_{SW} \cdot 0.03 \cdot 10^{-3} \cdot R_{RAMP})\} / 10\mu A \quad (9)$$

where:

$$V_{BOT} = 0.96 + (I_{LOAD} \cdot R_{DSON} \cdot K_T \cdot 8);$$

$$V_{RMPEAK} = D \cdot (V_{IN} - 1.8) / (f_{SW} \cdot 0.03 \cdot 10^{-3} \cdot R_{RAMP});$$

I_{LOAD} = the desired maximum load current;

R_{DSON} = the nominal R_{DSON} of the low-side MOSFET;

K_T = the normalized temperature coefficient for the low-side MOSFET (on datasheet graph);

$D = V_{OUT} / V_{IN}$ duty cycle;

f_{SW} = Clock frequency in kHz; and

R_{RAMP} = chosen ramp resistor value in k Ω .

After 16 consecutive, pulse-by-pulse, current-limit cycles, the fault latch is set and the regulator shuts down. Cycling V_{CC} or EN restores operation after a normal soft-start cycle (refer to the Auto-Restart section).

The over-current protection fault latch is active during the soft-start cycle. Use 1% resistor for R_{ILIM} .

Loop Compensation

The loop is compensated using a feedback network around the error amplifier. Figure 23 shows a complete type-3 compensation network. For type-2 compensation, eliminate R_3 and C_3 .

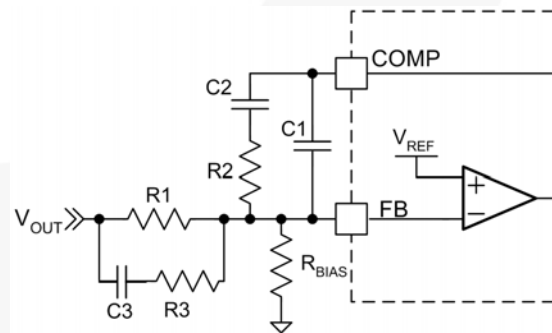

Figure 23. Compensation Network

Since the FAN2108 employs summing current-mode architecture, type-2 compensation can be used for many applications. For applications that require wide loop bandwidth and/or use very low-ESR output capacitors, type-3 compensation may be required.

Protection

The converter output is monitored and protected against extreme overload, short-circuit, over-voltage, under-voltage, and over-temperature conditions.

An internal fault latch is set for any fault intended to shut down the IC. When the fault latch is set, the IC discharges V_{OUT} by enhancing the low-side MOSFET until $FB < 0.25 V$. The MOSFET is not turned on again unless $FB > 0.5 V$. This behavior discharges the output without causing undershoot (negative output voltage).

Under-Voltage Shutdown

If voltage on the FB pin remains below the under-voltage threshold for 16 consecutive clock cycles, the fault latch is set and the converter shuts down. This protection is not active until the internal SS ramp reaches 1.0 V during soft-start.

Over-Voltage Protection / Shutdown

If voltage on the FB pin exceeds the over-voltage threshold for two consecutive clock cycles, the fault latch is set and shutdown occurs.

A shorted high-side MOSFET condition is detected when SW voltage exceeds $\sim 0.7 V$ while the low-side MOSFET is fully enhanced. The fault latch is set immediately upon detection.

The two fault protection circuits above are active all the time, including during soft-start.

Auto-Restart

After a fault, EN pin is discharged by a 1 μA current sink to a 1.1 V threshold before the internal 800 K Ω pull-up is restored. A new soft-start cycle begins when EN charges above 1.35 V.

Depending on the external circuit, the FAN2108 can be configured to remain latched-off or to automatically restart after a fault.

Table 1. Fault / Restart Configurations

EN Pin	Controller / Restart State
Pull to GND	OFF (Disabled)
Pull-up to V_{CC} with 100K	No Restart – Latched OFF (After V_{CC} Comes Up)
Open	Immediate Restart After Fault
Cap. to GND	New Soft-Start Cycle After: $t_{DELAY} (ms) = 3.9 \cdot C(nf)$

With EN is left open, restart is immediate.

If auto-restart is not desired, tie the EN pin to the VCC pin or pull it HIGH after V_{CC} comes up with a logic gate to keep the 1 μA current sink from discharging EN to 1.1 V. Figure 24 shows one method to pull up EN to V_{CC} for a latch configuration.

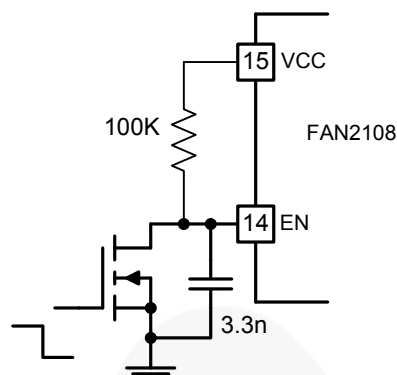

Figure 24. Enable Control with Latch Option

Over-Temperature Protection (OTP)

The chip incorporates an over-temperature protection circuit that sets the fault latch when a die temperature of about 150°C is reached. The IC restarts when the die temperature falls below 125°C.

Power-Good (PGOOD) Signal

PGOOD is an open-drain output that asserts LOW when V_{OUT} is out of regulation, as measured at the FB pin. Thresholds are specified in the Electrical Specifications section. PGOOD does not assert HIGH until the fault latch is enabled (T1.0).

PCB Layout

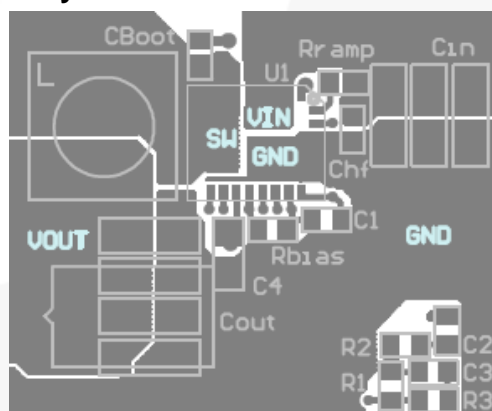
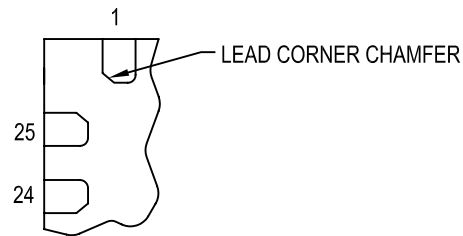
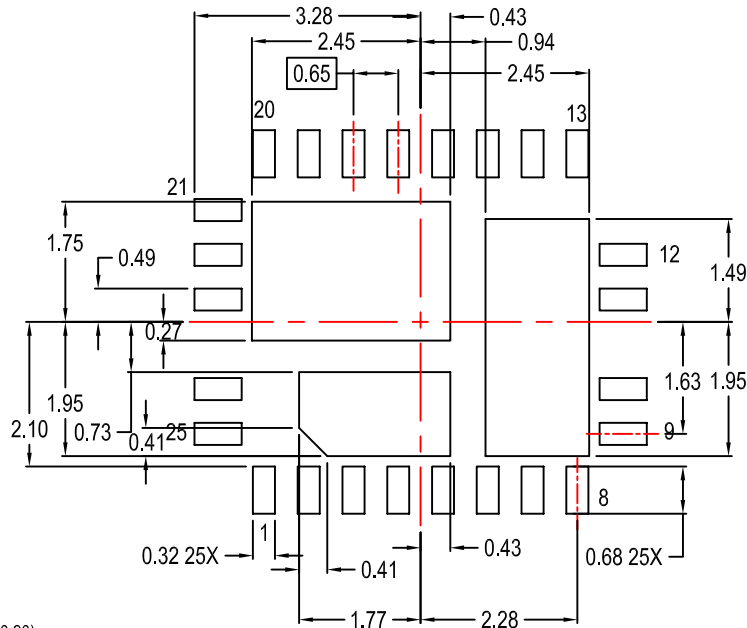
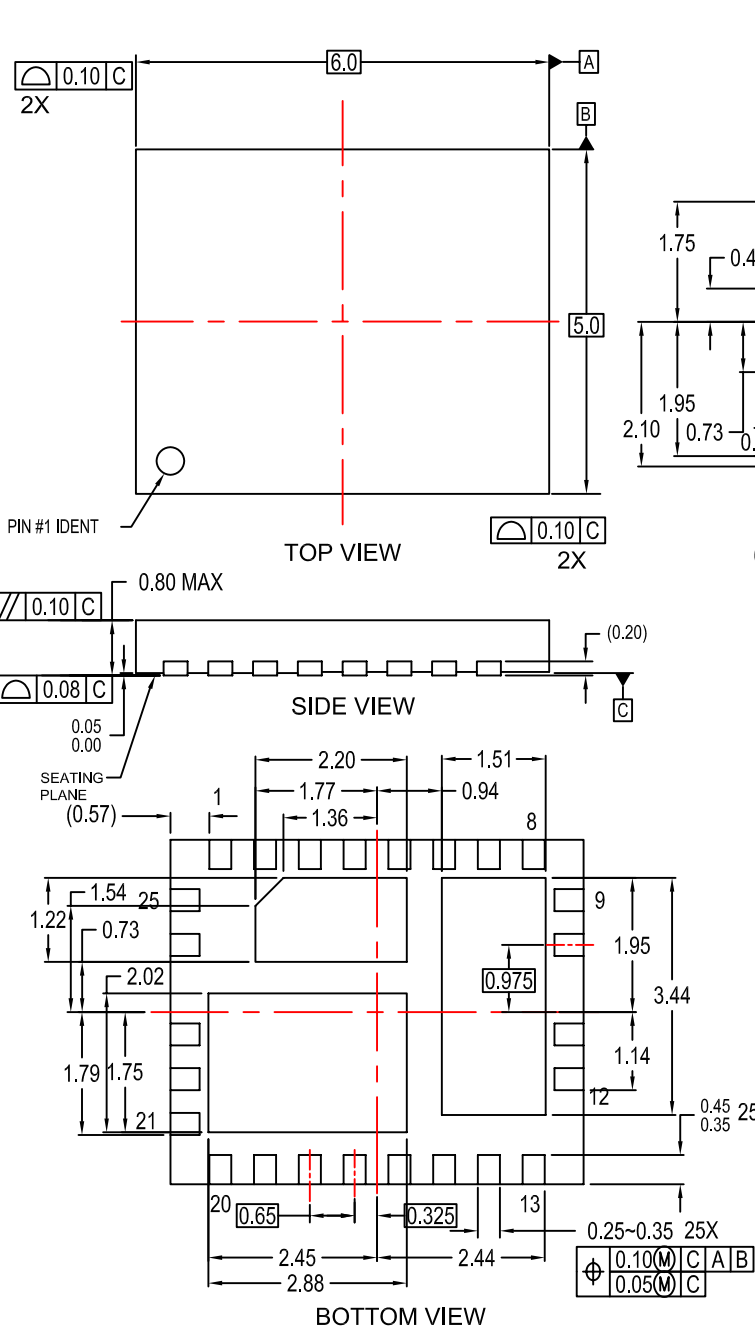

Figure 25. Recommended PCB Layout

REVISIONS			
LTR	DESCRIPTION	DATE	BY/SITE
1	RELEASE TO DOCUMENT CONTROL	12-Jul-2007	J.Chan/FSPM
2	ADDED DIMENSIONS TO BOTTOM VIEW AND LANDPATTERN RECOMMENDATION	7-SEPT-2007	H.ALLEN/FSME
3	CHAMFERED LANDPATTERN PAD 1	17-JUN-2009	H.ALLEN/FSME



- NOTES: UNLESS OTHERWISE SPECIFIED**
- A) DIMENSIONS ARE IN MILLIMETERS.
 - B) DIMENSIONS AND TOLERANCES PER ASME Y14.5M, 1994
 - C) DIMENSIONS DO NOT INCLUDE MOLD FLASH OR BURRS.
 - D) DESIGN BASED ON JEDEC MO-220 VARIATION WJHC
 - E) TERMINALS ARE SYMMETRICAL AROUND THE X & Y AXIS EXCEPT WHERE DEPOPULATED.
 - F) DRAWING FILENAME: MKT-MLP25AREV3

APPROVALS		DATE	Bayan Lepas, FIZ, 11900, Penang, Malaysia.		
DRAWN	H.ALLEN	7-SEPT-07			
DFTG. CHK.	S.MARTIN	7-SEPT-07			
ENGR. CHK.					
25LD, MLP, QUAD, NON-JEDEC, 6x5MM TRIPLE DAP					
		SCALE	SIZE	DRAWING NUMBER	REV
		N/A	N/A	MKT-MLP25A	3
DO NOT SCALE DRAWING				SHEET 1 of 1	



TRADEMARKS

The following includes registered and unregistered trademarks and service marks, owned by Fairchild Semiconductor and/or its global subsidiaries, and is not intended to be an exhaustive list of all such trademarks.

- AccuPower™
- AttitudeEngine™
- Awinda®
- AX-CAP®*
- BitSiC™
- Build it Now™
- CorePLUS™
- CorePOWER™
- CROSSVOL™
- CTL™
- Current Transfer Logic™
- DEUXPEED®
- Dual Cool™
- EcoSPARK®
- EfficientMax™
- ESBC™
- F**™
- Fairchild®
- Fairchild Semiconductor®
- FACT Quiet Series™
- FACT®
- FastvCore™
- FETBench™
- FPS™
- F-PFS™
- FRFET®
- Global Power ResourceSM
- GreenBridge™
- Green FPS™
- Green FPS™ e-Series™
- Gmax™
- GTO™
- IntelliMAX™
- ISOPLANAR™
- Making Small Speakers Sound Louder and Better™
- MegaBuck™
- MICROCOUPLER™
- MicroFET™
- MicroPak™
- MicroPak2™
- MillerDrive™
- MotionMax™
- MotionGrid®
- MTi®
- MTx®
- MVN®
- mWSaver®
- OptoHiT™
- OPTOLOGIC®
- OPTOPLANAR®
- ®
- Power Supply WebDesigner™
- PowerTrench®
- PowerXS™
- Programmable Active Droop™
- QFET®
- QS™
- Quiet Series™
- RapidConfigure™
- ™
- Saving our world, 1mW/W/kW at a time™
- SignalWise™
- SmartMax™
- SMART START™
- Solutions for Your Success™
- SPM®
- STEALTH™
- SuperFET®
- SuperSOT™-3
- SuperSOT™-6
- SuperSOT™-8
- SupreMOS®
- SyncFET™
- Sync-Lock™
- ®
- TinyBoost®
- TinyBuck®
- TinyCalc™
- TinyLogic®
- TINYOPTO™
- TinyPower™
- TinyPWM™
- TinyWire™
- TranSiC™
- TriFault Detect™
- TRUECURRENT®*
- μSerDes™
- ™
- UHC®
- Ultra FRFET™
- UniFET™
- VcX™
- VisualMax™
- VoltagePlus™
- XS™
- Xsens™
- 仙童®

* Trademarks of System General Corporation, used under license by Fairchild Semiconductor.

DISCLAIMER

FAIRCHILD SEMICONDUCTOR RESERVES THE RIGHT TO MAKE CHANGES WITHOUT FURTHER NOTICE TO ANY PRODUCTS HEREIN TO IMPROVE RELIABILITY, FUNCTION, OR DESIGN. TO OBTAIN THE LATEST, MOST UP-TO-DATE DATASHEET AND PRODUCT INFORMATION, VISIT OUR WEBSITE AT [HTTP://WWW.FAIRCHILDSEMI.COM](http://www.fairchildsemi.com). FAIRCHILD DOES NOT ASSUME ANY LIABILITY ARISING OUT OF THE APPLICATION OR USE OF ANY PRODUCT OR CIRCUIT DESCRIBED HEREIN; NEITHER DOES IT CONVEY ANY LICENSE UNDER ITS PATENT RIGHTS, NOR THE RIGHTS OF OTHERS. THESE SPECIFICATIONS DO NOT EXPAND THE TERMS OF FAIRCHILD'S WORLDWIDE TERMS AND CONDITIONS, SPECIFICALLY THE WARRANTY THEREIN, WHICH COVERS THESE PRODUCTS.

AUTHORIZED USE

Unless otherwise specified in this data sheet, this product is a standard commercial product and is not intended for use in applications that require extraordinary levels of quality and reliability. This product may not be used in the following applications, unless specifically approved in writing by a Fairchild officer: (1) automotive or other transportation, (2) military/aerospace, (3) any safety critical application – including life critical medical equipment – where the failure of the Fairchild product reasonably would be expected to result in personal injury, death or property damage. Customer's use of this product is subject to agreement of this Authorized Use policy. In the event of an unauthorized use of Fairchild's product, Fairchild accepts no liability in the event of product failure. In other respects, this product shall be subject to Fairchild's Worldwide Terms and Conditions of Sale, unless a separate agreement has been signed by both Parties.

ANTI-COUNTERFEITING POLICY

Fairchild Semiconductor Corporation's Anti-Counterfeiting Policy. Fairchild's Anti-Counterfeiting Policy is also stated on our external website, www.fairchildsemi.com, under Terms of Use

Counterfeiting of semiconductor parts is a growing problem in the industry. All manufacturers of semiconductor products are experiencing counterfeiting of their parts. Customers who inadvertently purchase counterfeit parts experience many problems such as loss of brand reputation, substandard performance, failed applications, and increased cost of production and manufacturing delays. Fairchild is taking strong measures to protect ourselves and our customers from the proliferation of counterfeit parts. Fairchild strongly encourages customers to purchase Fairchild parts either directly from Fairchild or from Authorized Fairchild Distributors who are listed by country on our web page cited above. Products customers buy either from Fairchild directly or from Authorized Fairchild Distributors are genuine parts, have full traceability, meet Fairchild's quality standards for handling and storage and provide access to Fairchild's full range of up-to-date technical and product information. Fairchild and our Authorized Distributors will stand behind all warranties and will appropriately address any warranty issues that may arise. Fairchild will not provide any warranty coverage or other assistance for parts bought from Unauthorized Sources. Fairchild is committed to combat this global problem and encourage our customers to do their part in stopping this practice by buying direct or from authorized distributors.

PRODUCT STATUS DEFINITIONS

Definition of Terms

Datasheet Identification	Product Status	Definition
Advance Information	Formative / In Design	Datasheet contains the design specifications for product development. Specifications may change in any manner without notice.
Preliminary	First Production	Datasheet contains preliminary data; supplementary data will be published at a later date. Fairchild Semiconductor reserves the right to make changes at any time without notice to improve design.
No Identification Needed	Full Production	Datasheet contains final specifications. Fairchild Semiconductor reserves the right to make changes at any time without notice to improve the design.
Obsolete	Not In Production	Datasheet contains specifications on a product that is discontinued by Fairchild Semiconductor. The datasheet is for reference information only.

Rev. I77