



# FAN21SV06 — TinyBuck™ 6 A, 24V Single-Input Integrated Synchronous Buck Regulator with Synchronization Capability

## Features

- Single-Supply Operation with 6 A Output Current
- Over 94% Efficiency
- Fully Synchronous Operation with Integrated Schottky Diode on Low-Side MOSFET Boosts Efficiency
- Single Supply Device for  $V_{IN} > 6.5\text{ V} - 24\text{ V}$
- Programmable Frequency Operation (200-600 KHz)
- Externally Synchronizable Clock with Master/Slave Provisions
- Wide Input Range with Dual Supply: 3.0 V to 24 V
- Output Voltage Range: 0.8 V to 80% $V_{IN}$
- Power-Good Signal
- Accepts Ceramic Capacitors on Output
- External Compensation for Flexible Design
- Starts Up on Pre-Bias Outputs
- Integrated Bootstrap Diode
- Programmable Over-Current Protection
- Under-Voltage, Over-Voltage, and Thermal-Shutdown Protections
- 5 x 6 mm, 25-pin, 3-pad MLP

## Applications

- Servers & Telecom
- Graphics Cards & Displays
- High-End Computing Systems
- Set-Top Boxes & Game Consoles
- Point-of-Load Regulation

## Description

The FAN210SV06 TinyBuck™ is a highly efficient, small-footprint, programmable-frequency, 6 A integrated synchronous buck regulator.

FAN21SV06 contains both synchronous MOSFETs and a controller/driver with optimized interconnects in one package, which enables designers to solve high-current requirements in a small area with minimal external components, thereby saving cost. On-board internal 5 V regulator enables single-supply operation for input voltages  $>6.5\text{ V}$ .

The FAN21SV06 can be configured to drive multiple slave devices OR synchronize to an external system clock. In slave mode, FAN21SV06 may be set up to be free-running in the absence of a master clock signal.

External compensation, programmable switching frequency, and current-limit features allow for design optimization and flexibility. High-frequency operation allows for all ceramic solutions.

Fairchild's advanced BiCMOS power process combined with low- $R_{DS(ON)}$  internal MOSFETs and a thermally efficient MLP package provide the ability to dissipate high power in a small package. Integration helps to minimize critical inductances making layout simpler and more efficient compared to discrete solutions.

Output over-voltage, under-voltage, over-current and thermal-shutdown protections help protect the device from damage during fault conditions. FAN21SV06 prevents pre-biased output discharge during startup in point-of-load applications.

## Related Resources

- [TinyCalc™ Calculator Design Tool AN-6033 — FAN21SV06 Design Guide](#)
- [AN-8022 — TinyCalc™ Calculator](#)

## Ordering Information

Part Number	Operating Temperature Range	Package	Packing Method
FAN21SV06MPX	-10°C to 85°C	Molded Leadless Package (MLP) 5 x 6 mm	Tape and Reel
FAN21SV06EMPX	-40°C to 85°C		

### Typical Application Diagram

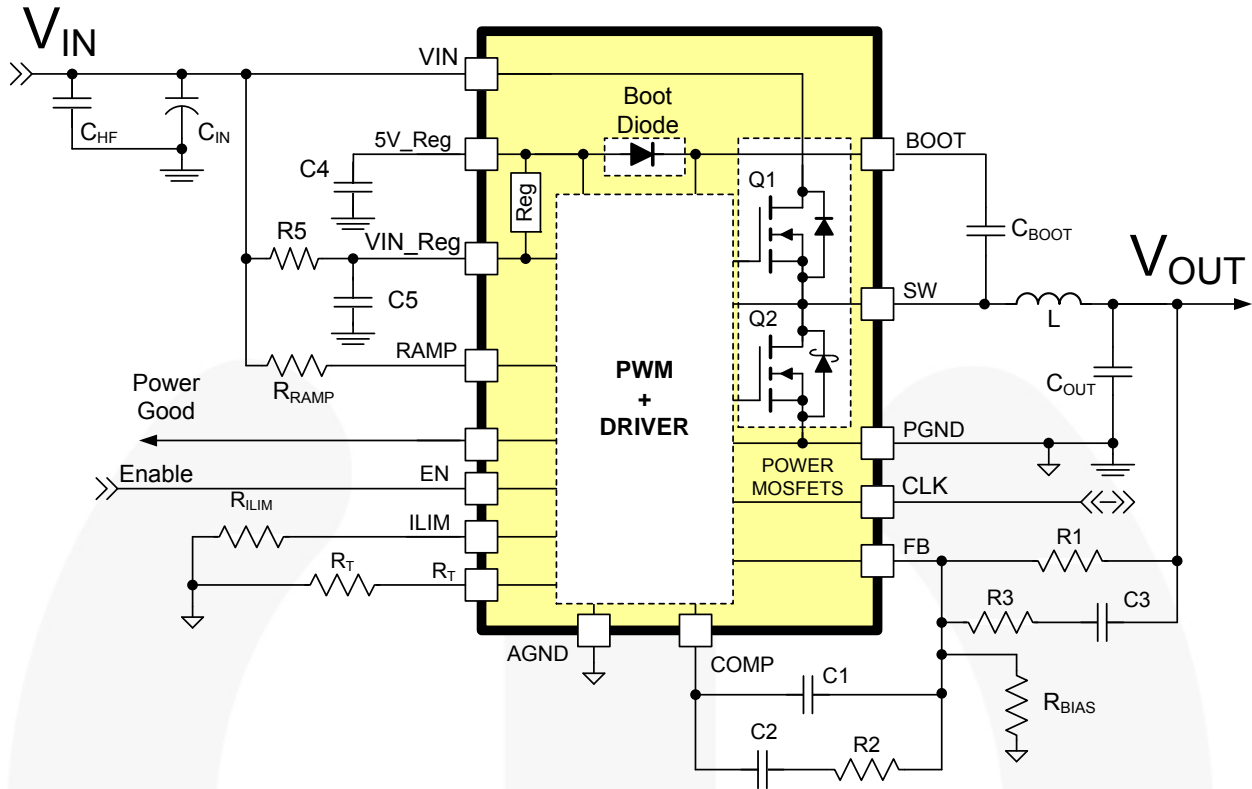


Figure 1. Typical Application, Master,  $V_{IN}=6.5\text{ V to }24\text{ V}$

### Block Diagram

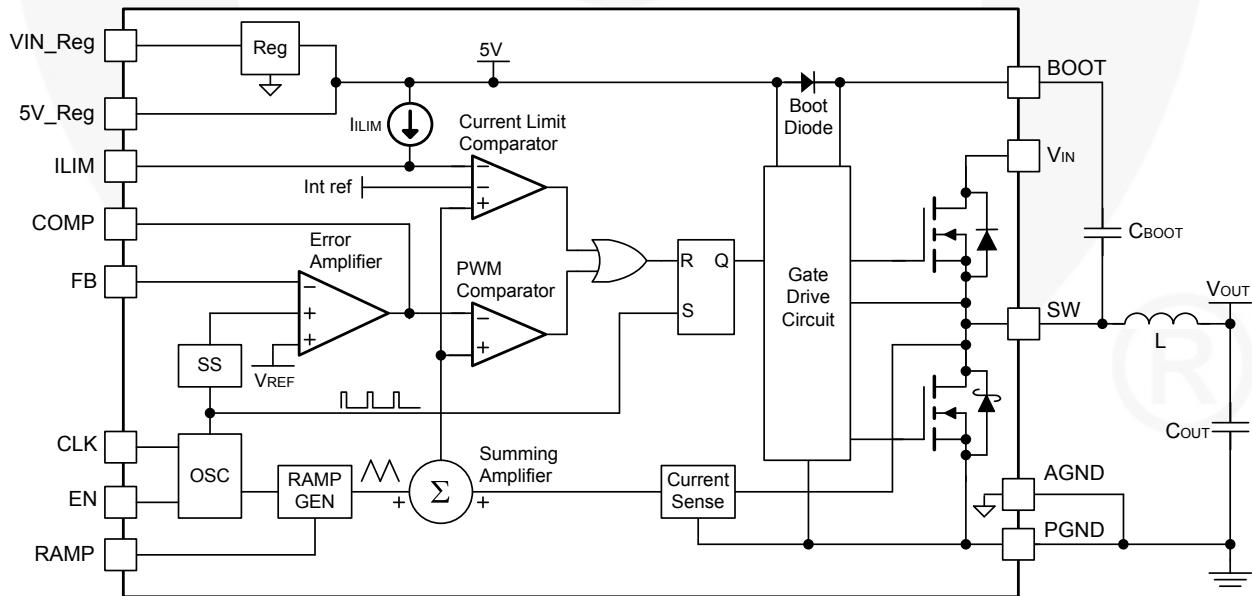


Figure 2. Block Diagram

## Pin Configuration

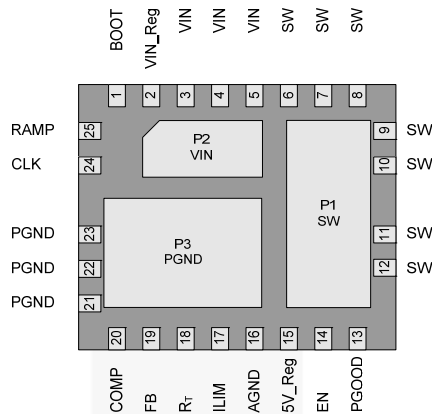


Figure 3. MLP 5 x 6 mm Pin Configuration (Bottom View)

## Pad / Pin Definitions

Pad / Pin	Name	Description
P1, 6-12	SW	<b>Switching Node.</b> Junction of high-side and low-side MOSFETs.
P2, 3-5	VIN	<b>Power Input Voltage.</b> Supply voltage for the converter.
P3, 21-23	PGND	<b>Power Ground.</b> Power return and Q2 source.
1	BOOT	<b>High-Side Drive BOOT Voltage.</b> Connect through capacitor ( $C_{BOOT}$ ) to SW. The IC has an internal synchronous bootstrap diode to recharge the capacitor on this pin to 5 V.
2	VIN_Reg	<b>Regulator Input Voltage.</b> Input voltage to the internal regulator. Connect to input voltage >6.5 V with 1 $\mu$ F bypass capacitor at the pin.
13	PGOOD	<b>Power-Good.</b> An open-drain output that pulls LOW when the voltage on the FB pin is outside the limits specified in the electrical specs. PGOOD does not assert HIGH until the fault latch is enabled.
14	EN	<b>ENABLE.</b> Enables operation when pulled to logic HIGH or left open. Toggling EN resets the regulator after a latched-fault condition. This input has an internal pull-up. When a latched fault occurs, EN is discharged by a current sink.
15	5V_Reg	<b>5V Regulator Output.</b> Internal regulator output that provides power for the IC's logic and analog circuitry. This pin should be connected to AGND through a >2.2 $\mu$ F X5R/X7R capacitor.
16	AGND	<b>Analog Ground.</b> The signal ground for the IC. All internal control voltages are referred to this pin. Tie this pin to the ground island/plane through the lowest impedance connection.
17	ILIM	<b>Current Limit.</b> A resistor ( $R_{ILIM}$ ) from this pin to AGND can be used to program the current-limit trip threshold lower than the internal default setting.
18	$R_T$	<b>Oscillator Frequency and Master/Slave Set.</b> Connecting a resistor ( $R_T$ ) to AGND sets the oscillator frequency and configures the CLK pin as an output (master). Tying this pin to 5 V_Reg through a resistor configures the CLK signal as an input (slave) and establishes the free-running oscillator frequency.
19	FB	<b>Output Voltage Feedback.</b> Connect through a resistor divider to the output voltage.
20	COMP	<b>Compensation.</b> Error amplifier output. Connect the external compensation network between this pin and FB.
24	CLK	<b>Clock.</b> Bi-directional signal pin, depending on master/slave configuration. When configured as a master, this pin represents the clock output that connects directly to the slave(s) for synchronizing with 180° phase shift.
25	RAMP	<b>Ramp Amplitude.</b> A resistor ( $R_{RAMP}$ ) connected from this pin to VIN sets the internal ramp amplitude and also provides voltage feedforward functionality.

## Absolute Maximum Ratings

Stresses exceeding the absolute maximum ratings may damage the device. The device may not function or be operable above the recommended operating conditions and stressing the parts to these levels is not recommended. In addition, extended exposure to stresses above the recommended operating conditions may affect device reliability. The absolute maximum ratings are stress ratings only.

Parameter	Conditions	Min.	Max.	Units
VIN, VIN_Reg to AGND	AGND=PGND		28	V
5V_Reg to AGND	AGND=PGND		6	V
BOOT to PGND			35	V
BOOT to SW		-0.5	6.0	V
SW to PGND	Continuous	-0.5	24.0	V
	Transient (t < 20 ns, f ≤ 600 KHz)	-5	30	V
All other pins		-0.3	6.0	V
ESD	Human Body Model, JESD22-A114	1.5		kV
	Charged Device Model, JESD22-C101	2.5		

## Recommended Operating Conditions

The Recommended Operating Conditions table defines the conditions for actual device operation. Recommended operating conditions are specified to ensure optimal performance to the datasheet specifications. Fairchild does not recommend exceeding them or designing to Absolute Maximum Ratings.

Symbol	Parameter	Conditions	Min.	Typ.	Max	Units
f <sub>SW</sub>	Switching Frequency		200	500	600	KHz
V <sub>IN</sub> , VIN_Reg	Supply Voltage for Power and Bias	VIN to PGND	3.0		24.0	V
		VIN_Reg to AGND	6.5		24.0	V
T <sub>A</sub>	Ambient Temperature	FAN21SV06MX	-10		+85	°C
		FAN21SV06EMX	-40		+85	°C
T <sub>J</sub>	Junction Temperature				+125	°C

## Thermal Information

Symbol	Parameter	Min.	Typ.	Max.	Units
T <sub>STG</sub>	Storage Temperature	-65		+150	°C
T <sub>L</sub>	Lead Soldering Temperature, 30sec			+300	°C
θ <sub>JC</sub>	Thermal Resistance: Junction-to-Case	P1 (Q2)		4	°C/W
		P2 (Q1)		7	°C/W
		P3		4	°C/W
θ <sub>J-PCB</sub>	Thermal Resistance: Junction-to-Mounting Surface <sup>(1)</sup>		35 <sup>(1)</sup>		°C/W
P <sub>D</sub>	Total Power Dissipation in the package, T <sub>A</sub> =25°C <sup>(1)</sup>			2.8	W

**Note:**

1. Typical thermal resistance when mounted on a four-layer, two-ounce PCB, as shown in Figure 37. Actual results are dependent upon mounting method and surface related to the design.

## Electrical Characteristics

Recommended operating conditions, using the circuit in Figure 1, with  $V_{IN}$ ,  $V_{IN\_Reg}=12$  V, unless otherwise noted.

Parameter	Conditions	Min.	Typ.	Max.	Units
<b>Power Supplies</b>					
Operating Current (VIN+VIN_Reg)	$V_{IN}=12$ V, 5 V_Reg open, CLK open, $f_{SW}=500$ KHz, No Load		22	30	mA
VIN_Reg Operating Current	EN=High, 5 V_Reg open, CLK open, $f_{SW}=500$ KHz		11		mA
VIN_Reg Quiescent Current	EN=High, FB=0.9 V		4	5	mA
VIN_Reg Standby Current	EN=0, $V_{IN}=12$ V			1	mA
5V_Reg Output Voltage	Internal $V_{CC}$ Regulator, No Load (6.5 V < $V_{IN\_Reg}$ < 24 V)	4.7	5.0	5.3	V
5V_Reg Max Current Load	$V_{IN\_Reg}=12$ V)			5	mA
VIN_Reg UVLO Threshold	Rising $V_{IN}$ , $V_{IN}=V_{IN\_Reg}$		5.6	6.3	V
	Falling $V_{IN}$ , $V_{IN}=V_{IN\_Reg}$			5	V
<b>Reference</b>					
Reference Voltage measured at FB (See Figure 4 for Temperature Coefficient)	FAN21SV06M, 25°C	794	800	806	mV
	FAN21SV06EM, 25°C	795	800	805	mV
<b>Oscillator</b>					
Frequency	$R_T=50$ k $\Omega$ to GND (Master Mode)	255	300	345	KHz
	$R_T=24$ k $\Omega$ to GND (Master Mode)	540	600	660	KHz
Frequency in Slave Mode compared to Master Mode	$R_T=24$ k $\Omega$ to 50k $\Omega$ to 5 V_Reg (Slave Mode)	-15		+15	%
Minimum On-Time <sup>(2)</sup>			40	65	ns
Duty Cycle	$V_{IN}=6.5$ V, $f_{SW}=600$ KHz		80	85	%
Ramp Amplitude, Peak-to-Peak <sup>(2)</sup>	16 $V_{IN}$ , 1.8 $V_{OUT}$ , $R_T=30$ k $\Omega$ , $R_{RAMP}=200$ k $\Omega$		0.5		V
Minimum Off-Time <sup>(2)</sup>			100	150	ns
<b>Synchronization</b>					
CLK Output Pulse Width	Master ( $R_T$ to GND)	70	85	100	ns
CLK Output Sink Current	Master, $V_{CLK}=0.4$ V	0.25		0.35	mA
CLK Output Source Current	Master, $V_{CLK}=2$ V	-2.5		-2.0	mA
CLK Input Pulse Width	Slave: $V_{CLK} \geq 2$ V	50			ns
CLK Input Source Current	Slave: $V_{CLK}=1$ V	-230	-200	-170	$\mu$ A
CLK Input Threshold, Rising	Slave	1.73	1.83	1.93	V
<b>Soft-Start</b>					
$V_{OUT}$ to Regulation ( $T_{0.8}$ )	Frequency=500 KHz		2.5		ms
Fault Enable/SSOK ( $T_{1.0}$ )			3.1		ms
<b>Error Amplifier</b>					
DC Gain <sup>(2)</sup>	$V_{IN\_Reg} > 6.5$ V	80	85		dB
Gain Bandwidth Product <sup>(2)</sup>		12	15		MHz
Output Voltage Swing ( $V_{COMP}$ )		0.4		4.0	V
Output Current, Sourcing	5V_Reg=5 V, $V_{COMP}=2.2$ V	1.5	2.2	2.5	mA
Output Current, Sinking	5V_Reg=5 V, $V_{COMP}=1.2$ V	0.8	1.2	1.5	mA
FB Bias Current	$V_{FB}=0.8$ V, 25°C	-850	-650	-450	nA

### Note:

- Specifications guaranteed by design and characterization; not production tested.

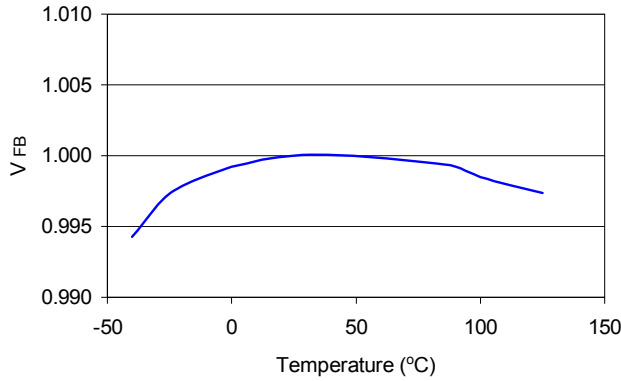
**Electrical Characteristics** (Continued)Recommended operating conditions using the circuit in Figure 1 with  $V_{IN}$ ,  $V_{IN\_Reg}=12$  V, unless otherwise noted.

Parameter	Conditions	Min.	Typ.	Max.	Units
<b>Control Functions</b>					
EN Threshold, Rising			1.35	2.00	V
EN Hysteresis			250		mV
EN Pull-Up Current	$V_{IN\_Reg} > 6.5$ V	-8	-6	-4	$\mu$ A
EN Discharge Current	Auto-Restart Mode, $V_{IN\_Reg} > 6.5$ V		1		$\mu$ A
FB OK Drive Resistance			800	1000	K $\Omega$
PGOOD LOW Threshold	$FB < V_{REF}$ , 2 Consecutive Clock Cycles <sup>(3)</sup>	-14.5	-11.0	-8.0	% $V_{REF}$
	$FB > V_{REF}$ , 2 Consecutive Clock Cycles <sup>(3)</sup>	+6.5	+10.0	+13.5	% $V_{REF}$
PGOOD Low Voltage	$I_{OUT} \leq 2$ mA			0.4	V
PGOOD Leakage Current	$V_{PGOOD}=5$ V		0.2	1.0	$\mu$ A
<b>Protection and Shutdown</b>					
Current Limit	$R_{LIM}$ Open, fsw=500 KHz., $V_{OUT}=1.8$ V, $R_{ramp}=200$ k $\Omega$ , 16 Consecutive Clock Cycles <sup>(3)</sup>	7	9	11	A
$I_{LIM}$ Current	$V_{IN\_Reg} > 6.5$ V, 25°C	-11	-10	-9	$\mu$ A
Over-Temperature Shutdown	Internal Temperature		155		°C
Over-Temperature Hysteresis			30		°C
Over-Voltage Threshold	2 Consecutive Clock Cycles <sup>(3)</sup>	110	115	120	% $V_{OUT}$
Under-Voltage Shutdown	16 Consecutive Clock Cycles <sup>(3)</sup>	68	73	78	% $V_{OUT}$
Fault-Discharge Threshold	Measured at FB pin		250		mV
Fault-Discharge Hysteresis	Measured at FB pin ( $V_{FB} \sim 50$ mV)		250		mV

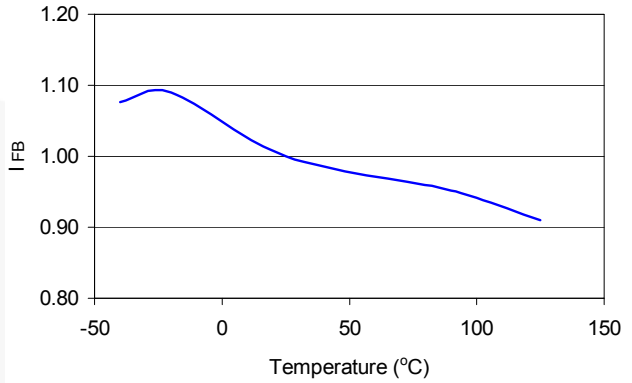
**Note:**

3. Delay times are not tested in production. Guaranteed by design.

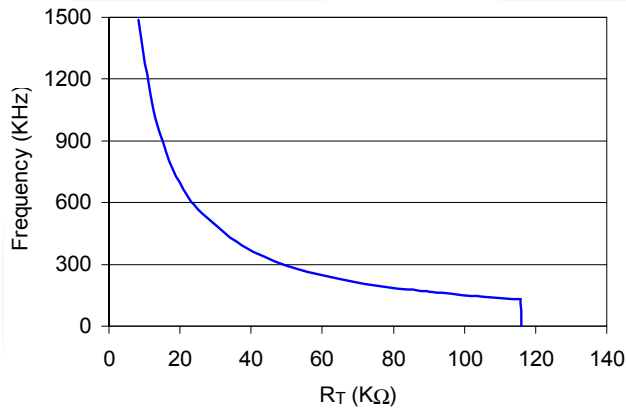
## Typical Characteristics



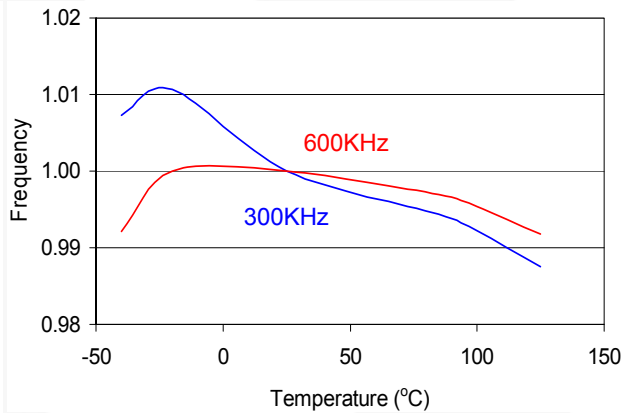
**Figure 4. Reference Voltage ( $V_{FB}$ ) vs. Temperature, Normalized**



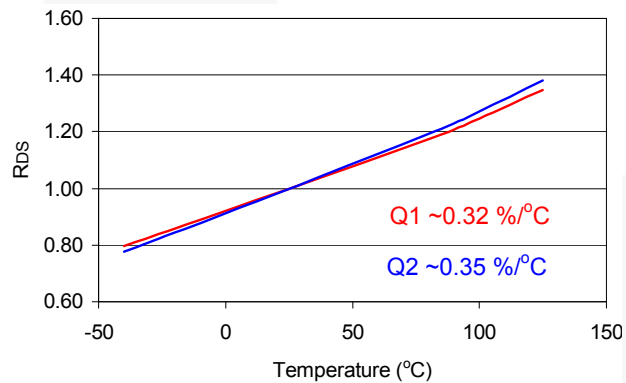
**Figure 5. Reference Bias Current ( $I_{FB}$ ) vs. Temperature, Normalized**



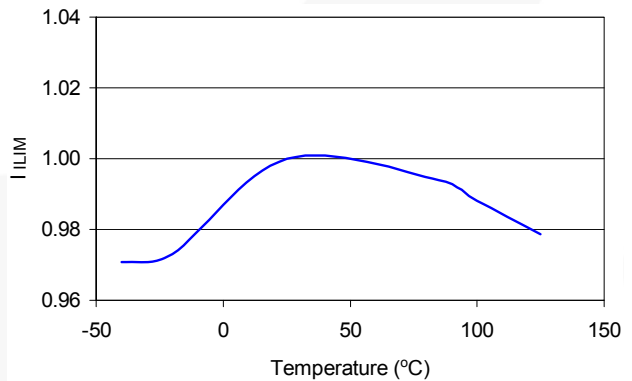
**Figure 6. Frequency vs.  $R_T$  (Master)**



**Figure 7. Frequency vs. Temperature, Normalized**



**Figure 8.  $R_{DS}$  vs. Temperature, Normalized ( $5 V_{Reg}=V_{GS}=5 V$ )**



**Figure 9.  $I_{ILIM}$  Current ( $I_{ILIM}$ ) vs. Temperature, Normalized**

### Application Circuit

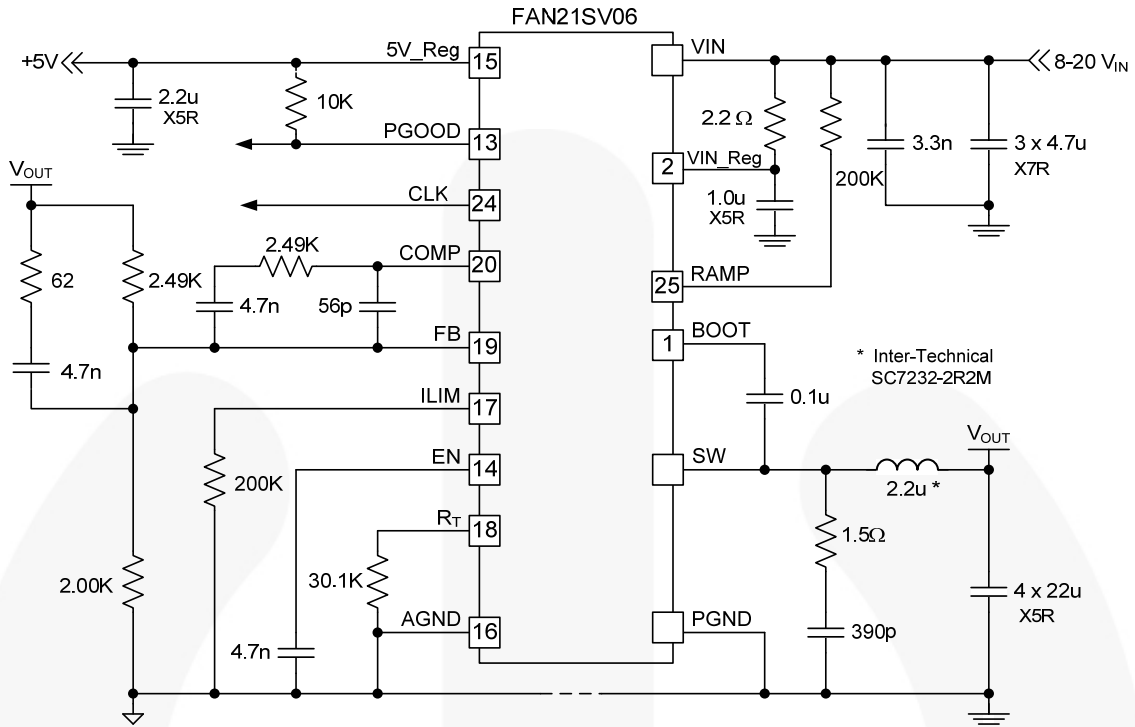


Figure 10. Single-Supply Application Circuit: 1.8 V<sub>OUT</sub>, 500 KHz, Master

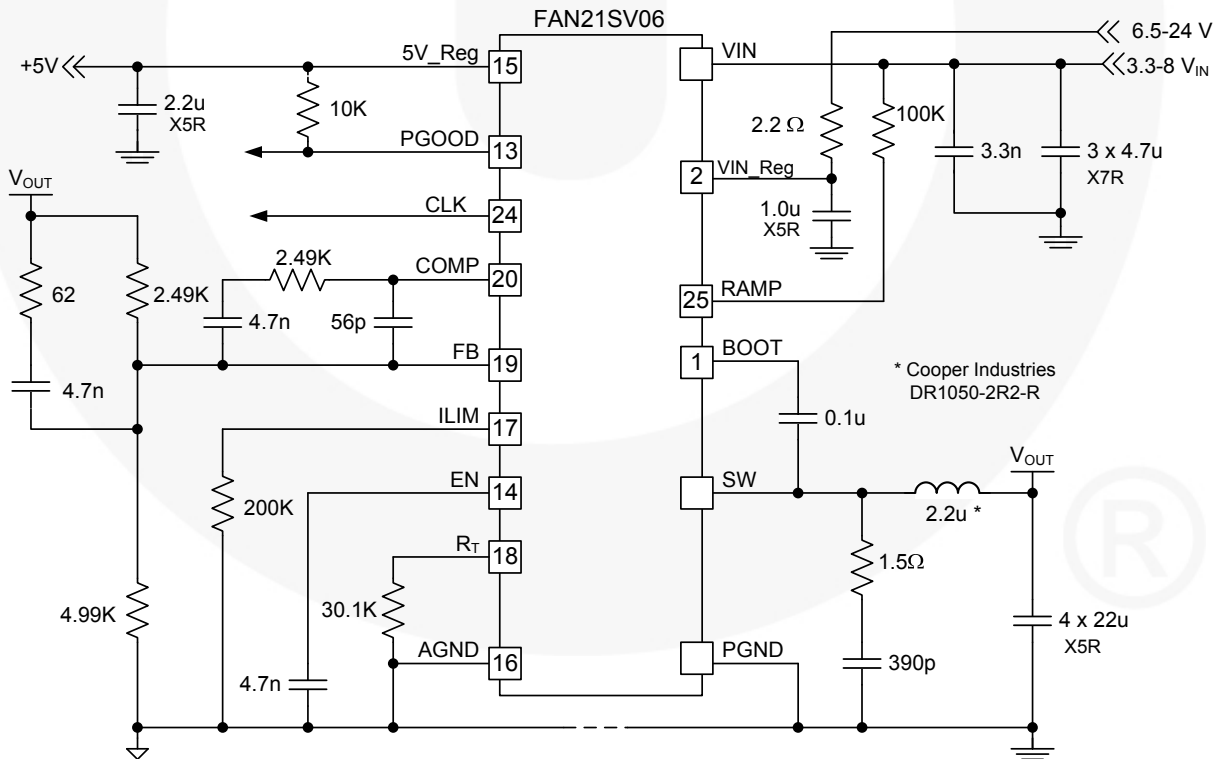


Figure 11. Dual-Supply Application Circuit: 1.2 V<sub>OUT</sub>, 600 KHz, Master 3.3 V – 8 V Input

## Typical Performance Characteristics

Typical operating characteristics using the circuit shown in Figure 10, unless otherwise specified.

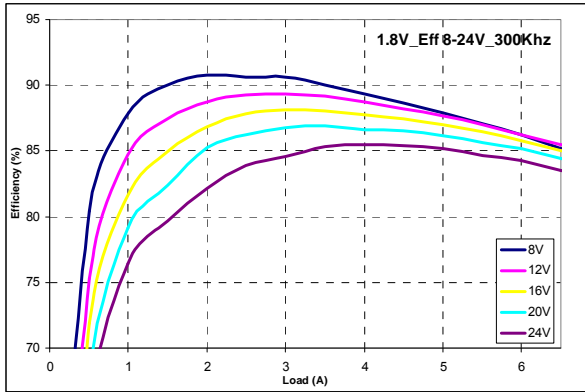


Figure 12. 1.8 V<sub>OUT</sub> Efficiency Over V<sub>IN</sub> vs. Load

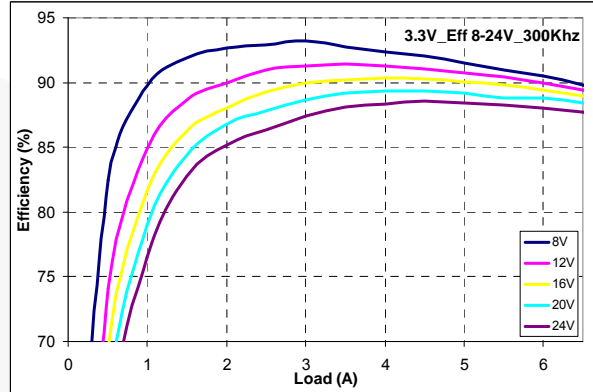


Figure 13. 3.3 V<sub>OUT</sub> Efficiency vs. Load (Circuit Value Changes)

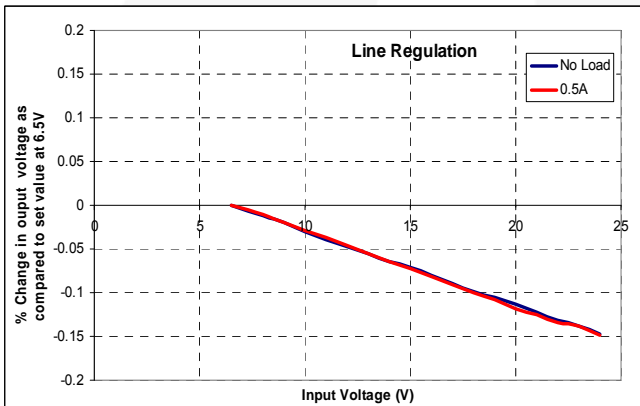


Figure 14. 1.8 V<sub>OUT</sub> Line Regulation

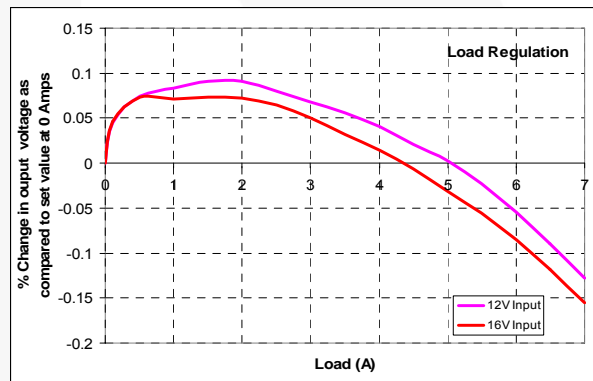


Figure 15. 1.8 V<sub>OUT</sub> Load Regulation

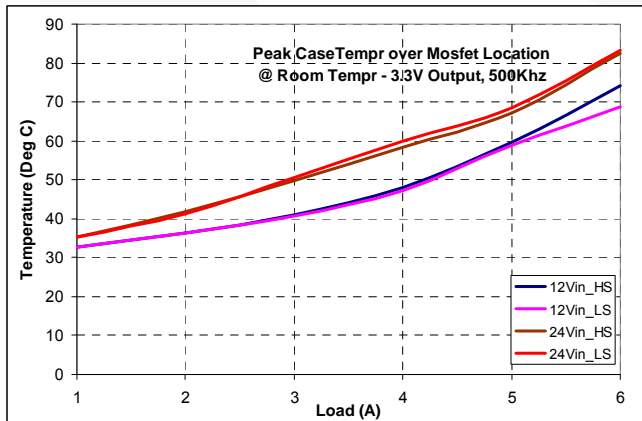


Figure 16. Peak Case Temp over MOSFET Locations  
3.3 V Output, 12 V and 24 V Input (500 KHz)

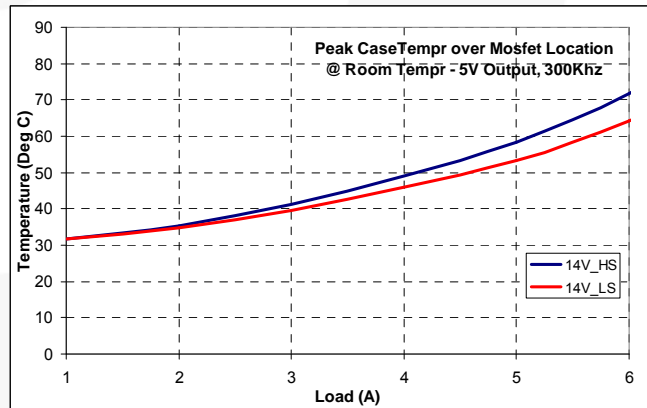


Figure 17. Peak Case Temp. Over MOSFET Locations  
5 V Output (300 KHz)

## Typical Performance Characteristics (Continued)

Typical operating characteristics using the circuit shown in Figure 10.  $V_{IN}=12\text{ V}$ , unless otherwise specified.

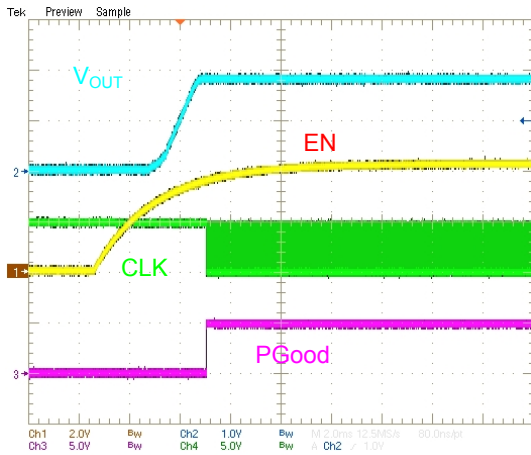


Figure 18. CLK and  $V_{OUT}$  at Startup

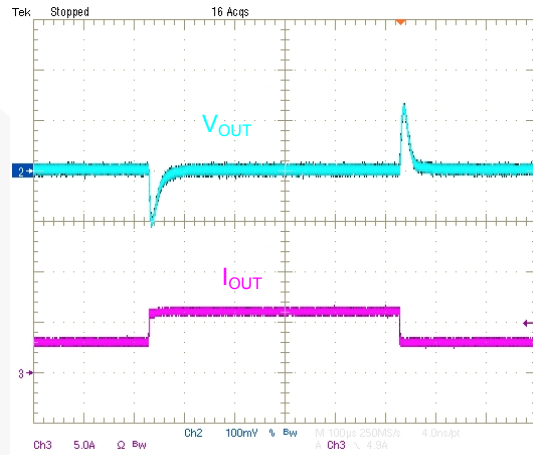


Figure 19. Transient Response, 3-6 A Load

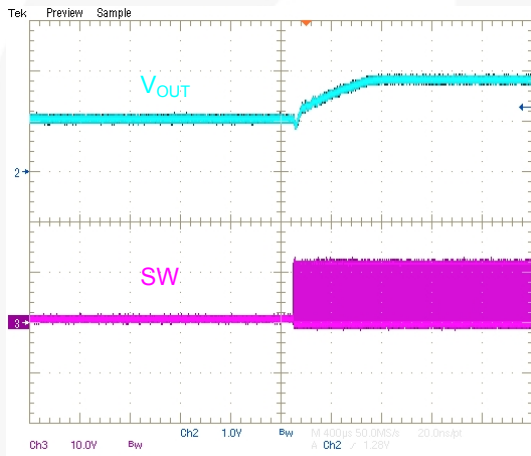


Figure 20. Startup on Pre-Bias

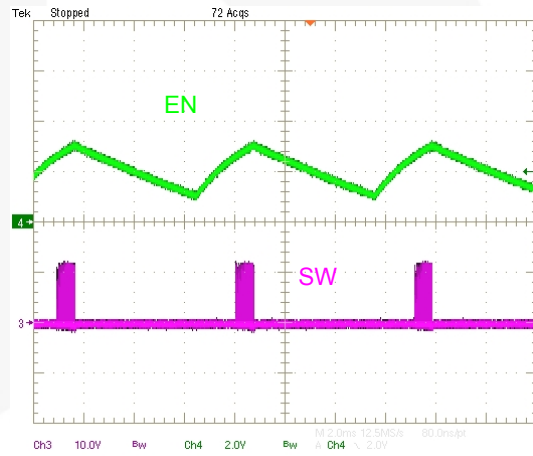


Figure 21. Restart on Fault

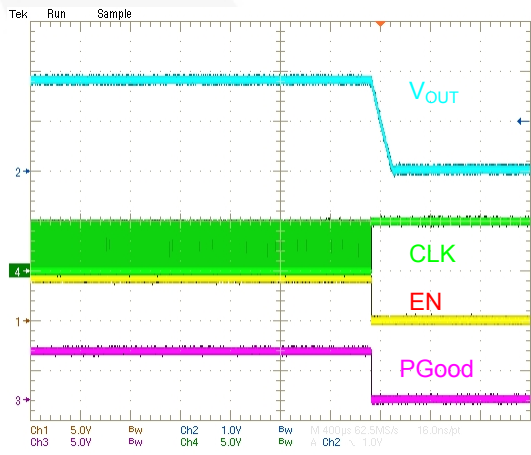


Figure 22. Shutdown, 1 A Load

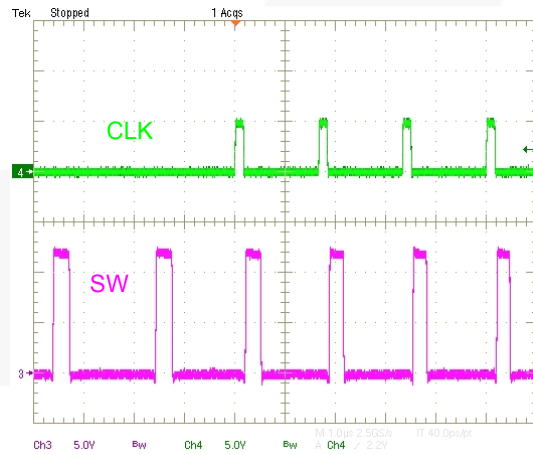


Figure 23. Slave (500 KHz Free-Run to 600 KHz Synchronization)

## Typical Performance Characteristics (Continued)

Typical operating characteristics using the circuit shown in Figure 10, unless otherwise specified.

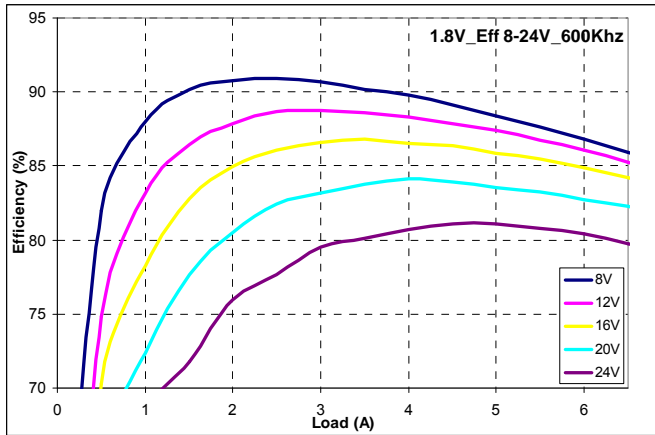


Figure 24. 1.8 V<sub>OUT</sub> Efficiency 600 KHz

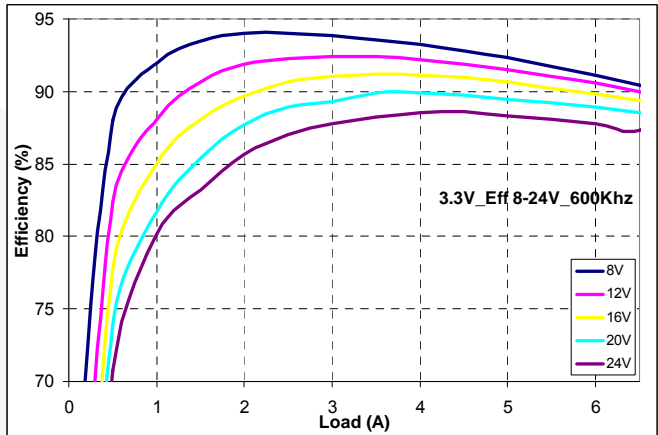


Figure 25. 3.3 V<sub>OUT</sub> Efficiency 600 KHz

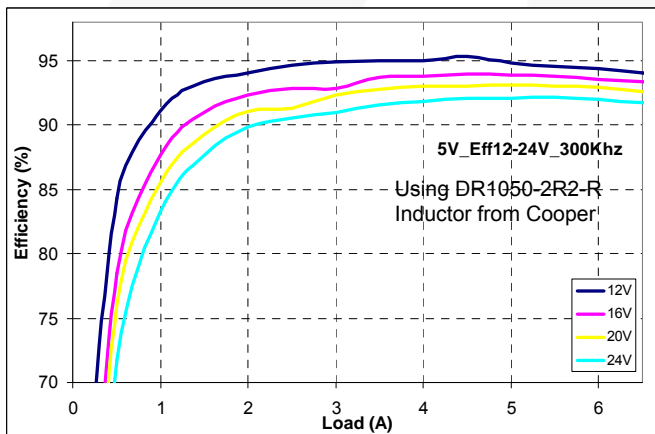


Figure 26. 5 V<sub>OUT</sub> Efficiency 300 KHz (Circuit Values Change)

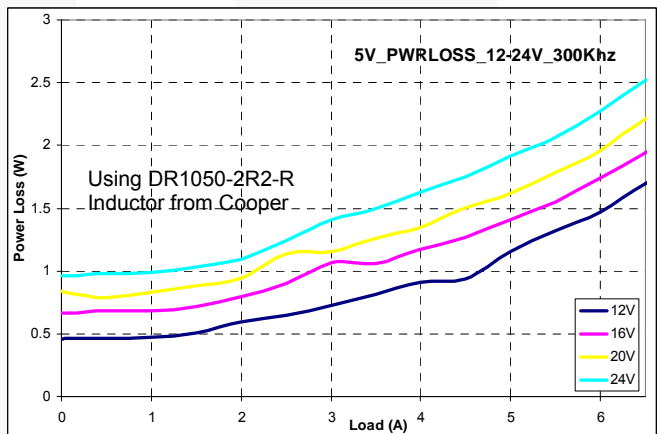


Figure 27. Device Power Loss (5 V<sub>OUT</sub>, 300 KHz) (Circuit Values Change)

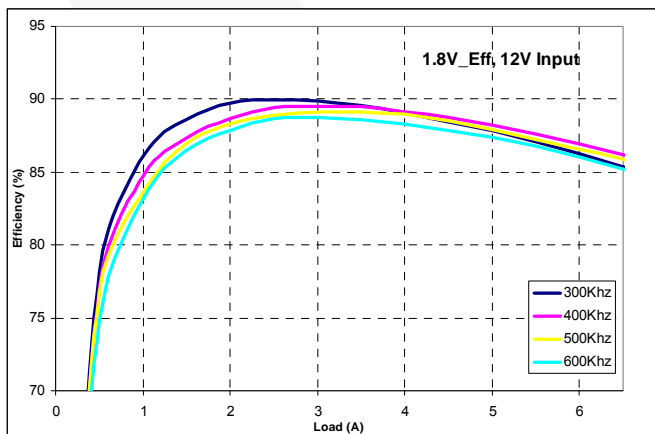


Figure 28. 1.8 V<sub>OUT</sub> Efficiency Over  $f_{sw}$  (Circuit Values Change)

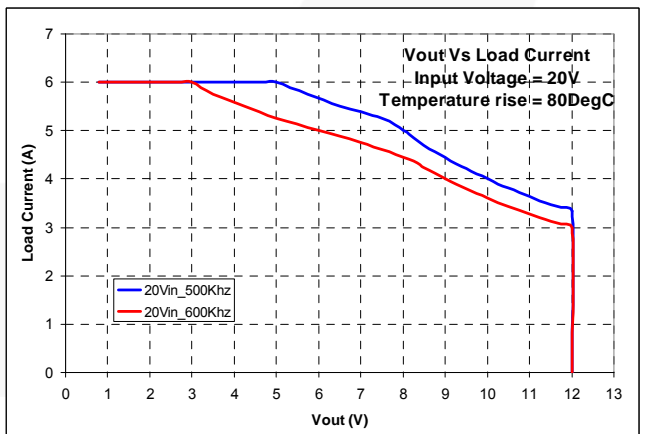


Figure 29. Typical Output Operating Area Based on Thermal Limitations (Circuit Values Change)

## Circuit Operation

### PWM Generation

Refer to Figure 2 for the PWM control mechanism. FAN21SV06 uses the summing-mode method of control to generate the PWM pulses. An amplified current-sense signal is summed with an internally generated ramp and the combined signal is compared with the output of the error amplifier to generate the pulse width to drive the high-side MOSFET. Sensed current from the previous cycle is used to modulate the output of the summing block. The output of the summing block is also compared against a voltage threshold set by the  $R_{LIM}$  resistor to limit the inductor current on a cycle-by-cycle basis. The controller facilitates external compensation for enhanced flexibility.

### Initialization

Once  $V_{IN\_Reg}$  voltage exceeds the UVLO threshold and EN is high, the IC checks for an open or shorted FB pin before releasing the internal soft-start ramp (SS).

If R1 is open (Figure 1), error amplifier output (COMP) is forced LOW and no pulses are generated. After the SS ramp times out (T1.0), an under-voltage fault occurs.

If the parallel combination of R1 and  $R_{BIAS}$  is  $\leq 1\text{ k}\Omega$ , the internal SS ramp is not released and the regulator does not start.

### Internal Regulator

FAN21SV06 facilitates single-supply operation for input voltages  $>6.5\text{ V}$ . At startup, the output of the internal regulator tracks the input voltage and comes into regulation (5 V) when  $V_{IN\_Reg}$  exceeds the UVLO threshold. The EN pin is released at the same time. The output voltage of the internal regulator (5 V\_Reg) is set to 5 V. The internal regulator supplies power to all the control circuits including the drivers.

For applications with  $V_{IN} < 6.5\text{ V}$ , FAN21SV06 can be used if  $V_{IN\_Reg}$  is provided with a separate low-power source  $>6.5\text{ V}$ .  $V_{IN\_Reg}$  supply should come up after  $V_{IN}$  during dual-supply operation. The  $V_{IN\_Reg}$  pin should always be decoupled with at least  $1\text{ }\mu\text{F}$  ceramic capacitor (see Figure 11).

Since  $V_{CC}$  is used to drive the internal MOSFET gates, high peak currents are present on the 5 V\_Reg pin. Connect a  $\geq 2.2\text{ }\mu\text{F}$  X5R or X7R decoupling capacitor between the 5 V\_Reg pin and PGND.

In addition to supplying power for the control circuits internally, 5 V\_Reg output can be used as a reference voltage for other applications requiring low noise reference voltage. 5 V\_Reg is capable of sourcing up to 5 mA of output current.

When EN is pulled LOW externally, 5 V\_Reg output is still present but the IC is in standby mode with no switching.

### Soft-Start

FAN21SV06 uses an internal digital soft-start circuit to slowly ramp up the output voltage and limit inrush current during startup. When 5 V\_Reg is in regulation and EN is high, the circuit releases SS and enables the PWM regulator. Soft-start time is a function of switching frequency (number of clock cycles).

Once internal SS ramp has charged to 0.8 V (T0.8), the output voltage is in regulation. Until SS ramp reaches 1.0 V (T1.0), only over-current-protection circuit is active during soft-start and all other output protections are inhibited.

In dual-supply operation mode, it is necessary to apply  $V_{IN}$  before  $V_{IN\_Reg}$  reaches its UVLO threshold to avoid skipping the soft-start cycle.

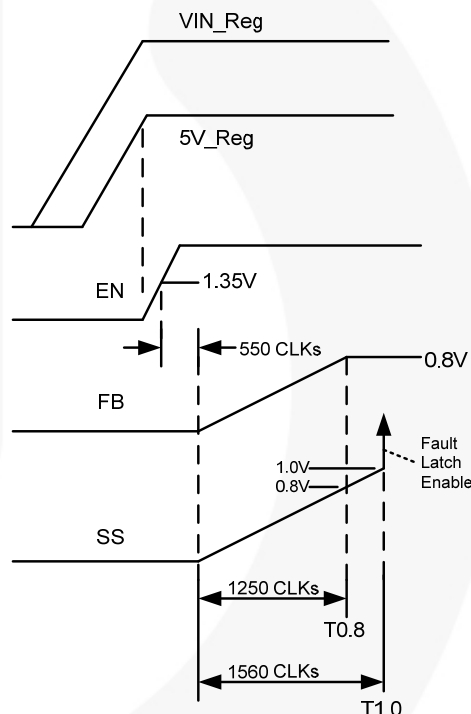


Figure 30. Typical Soft-Start Timing Diagram

$V_{IN\_Reg}$  UVLO or toggling the EN pin discharges the SS and resets the IC.

### Startup on Pre-Bias

The regulator does not allow the low-side MOSFET to operate in full synchronous mode until SS reaches 95% of  $V_{REF}$  ( $\sim 0.76\text{ V}$ ). This enables the regulator to startup on a pre-biased output and ensures that output is not discharged during the soft-start cycle.

### Protections

The converter output is monitored and protected against extreme overload, short-circuit, over-voltage, and under-voltage conditions.

## Under-Voltage Protection

If FB remains below the under-voltage threshold for 16 consecutive clock cycles, the fault latch is set and the converter shuts down. This fault is prevented from setting the fault latch during soft-start.

## Over-Voltage Protection

If FB exceeds  $115\% \cdot V_{REF}$  for two consecutive clock cycles, the fault latch is set and shutdown occurs.

A shorted high-side MOSFET condition is detected when SW voltage exceeds  $\sim 0.7$  V while the low-side MOSFET is fully enhanced. The fault latch is set immediately upon detection.

These two fault conditions are allowed to set the fault latch at any time, including during soft-start.

## Over-Temperature Protection

The chip incorporates an over-temperature-protection circuit that sets the fault latch when a die temperature of about  $155^{\circ}\text{C}$  is reached. The IC is allowed to restart when the die temperature falls below  $125^{\circ}\text{C}$ .

## EN / Auto-Restart

After a fault, EN pin is discharged with  $1 \mu\text{A}$  current pull down to a 1.1 V threshold before the internal  $800 \text{ k}\Omega$  pull up is restored. A new soft-start cycle begins when EN charges above 1.35 V.

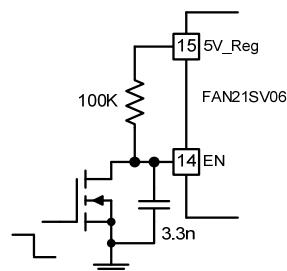
Depending on the external circuit, the FAN21SV06 can be configured to remain latched off or automatically restart after a fault, as listed in Table 1.

**Table 1. Fault / Restart Configurations**

EN pin	Controller / Restart State
Pull to GND	Standby
Connected to 5 V_Reg	No restart – latched OFF
Open	Immediate restart after fault
Cap to GND	New soft-start cycle after: EN is HIGH (Auto Restart Mode)

With EN left open, restart is immediate.

If auto-restart is not desired, tie the EN pin high with a logic gate to keep the  $1 \mu\text{A}$  current sink from discharging EN to 1.1 V. Figure 31 shows one method to pull up EN to  $V_{CC}$  for a latch configuration.



**Figure 31. Enable Control with Latch Option**

## Power Good (PGOOD) Signal

PGOOD is an open-drain output that asserts LOW when  $V_{OUT}$  is out of regulation, as measured at the FB pin. The thresholds are specified in the Electrical Specifications section. PGOOD does not assert HIGH until soft start is complete (T1.0).

## Application Information

### Setting the Output Voltage

The output voltage of the regulator can be set from 0.8 V to  $\sim 80\%$  of  $V_{IN}$  by an external resistor divider ( $R_1$  and  $R_{BIAS}$  in Figure 1). For output voltages  $> 3.3$  V, output current rating may need to be de-rated depending on the ambient temperature, power dissipated in the package and the PCB layout. (Refer to Thermal Information table and Figure 29.)

The internal reference is set to 0.8 V with  $650 \text{ nA}$  sourced from the FB pin to ensure that the regulator does not start if the pin is left open.

The external resistor divider is calculated using:

$$\frac{0.8\text{V}}{R_{BIAS}} = \frac{V_{OUT} - 0.8\text{V}}{R_1} + 650\text{nA} \quad (1)$$

Connect  $R_{BIAS}$  between FB and AGND.

### Setting the Clock Frequency

Oscillator frequency is determined by a resistor,  $R_T$ , that is connected between the ( $R_T$ )pin and AGND (Master Mode) or 5 V\_Reg (Slave Mode):

$$f_{(KHz)} = \frac{10^6}{(65 \cdot R_T) + 135} \quad (2)$$

where  $R_T$  is expressed in  $\text{k}\Omega$ .

$$R_{T(K\Omega)} = \frac{(10^6 / f) - 135}{65} \quad (3)$$

where frequency (f) is expressed in KHz. In slave mode, the switching frequency is about 10% slower for the same  $R_T$ .

The regulator does not start if  $R_T$  is open in Master mode.

### Calculating the Inductor Value

Typically the inductor value is chosen based on ripple current ( $\Delta I_L$ ) which is chosen between 10 to 35% of the maximum DC load. Regulator designs that require fast transient response use a higher ripple-current setting while regulator designs that require higher efficiency keep ripple current on the low side and operate at a lower switching frequency.

$$\Delta I_L = \frac{V_{OUT} \cdot (1-D)}{L \cdot f} \quad (4)$$

where  $f$  is the oscillator frequency, and

$$L = \frac{V_{OUT} \cdot (1-D)}{\Delta I_L \cdot f} \quad (5)$$

### Setting the Ramp-Resistor Value

As a starting point, set the internal ramp amplitude ( $\Delta V_{RAMP}$ ) to 0.5 V.  $R_{RAMP}$  is approximately:

$$R_{RAMP(K\Omega)} = \frac{(V_{IN} - 1.8) \cdot V_{OUT} - 2}{18 \times 10^{-6} \cdot V_{IN} \cdot f} \quad (6)$$

where frequency ( $f$ ) is expressed in KHz.

Refer to [AN-6033 — FAN21SV06 Design Guide](#) to determine the optimal  $R_{RAMP}$  value.

### Setting the Current Limit

The current limit system involves two comparators. The MAX  $I_{LIMIT}$  comparator is used with a  $V_{ILIM}$  fixed-voltage reference and represents the maximum current limit allowable. This reference voltage is temperature compensated to reflect the  $R_{DS(ON)}$  variation of the low-side MOSFET. The ADJUST  $I_{LIMIT}$  comparator is used where the current limit needs to be set lower than the  $V_{ILIM}$  fixed reference. The 10  $\mu A$  current source does not track the  $R_{DS(ON)}$  changes over temperature, so change is added into the equations for calculating the ADJUST  $I_{LIMIT}$  comparator reference voltage, as is shown below. Figure 32 shows a simplified schematic of the over-current system.

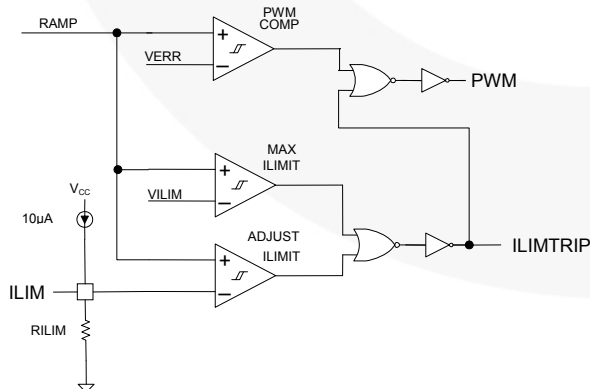


Figure 32. Current-Limit System Schematic

Since the  $I_{LIMIT}$  voltage is set by a 10  $\mu A$  current source into the  $R_{ILIM}$  resistor, the basic equation for setting the reference voltage is:

$$V_{RILIM} = 10\mu A \cdot R_{ILIM} \quad (7)$$

To calculate  $R_{ILIM}$ :

$$R_{ILIM} = V_{RILIM} / 10\mu A \quad (8)$$

The voltage  $V_{RILIM}$  is made up of two components,  $V_{BOT}$  (which relates to the current through the low-side MOSFET) and  $V_{RMPEAK}$  (which relates to the peak current through the inductor). Combining those two voltage terms results in:

$$R_{ILIM} = (V_{BOT} + V_{RMPEAK}) / 10\mu A \quad (9)$$

$$R_{ILIM} = \{0.96 + (I_{LOAD} \cdot R_{DS(ON)} \cdot K_T \cdot 8)\} + \{D \cdot (V_{IN} - 1.8) / (f_{SW} \cdot 0.03 \cdot 10^{-3} \cdot R_{RAMP})\} / 10\mu A \quad (10)$$

where:

$$V_{BOT} = 0.96 + (I_{LOAD} \cdot R_{DS(ON)} \cdot K_T \cdot 8);$$

$$V_{RMPEAK} = D \cdot (V_{IN} - 1.8) / (f_{SW} \cdot 0.03 \cdot 10^{-3} \cdot R_{RAMP});$$

$I_{LOAD}$  = the desired maximum load current;

$R_{DS(ON)}$  = the nominal  $R_{DS(ON)}$  of the low-side MOSFET;

$K_T$  = the normalized temperature coefficient for the low-side MOSFET (on datasheet graph);

$D$  =  $V_{OUT} / V_{IN}$  duty cycle;

$f_{SW}$  = Clock frequency in kHz; and

$R_{RAMP}$  = chosen ramp resistor value in k $\Omega$ .

After 16 consecutive, pulse-by-pulse, current-limit cycles, the fault latch is set and the regulator shuts down. Cycling  $V_{CC}$  or EN restores operation after a normal soft-start cycle (refer to the Auto-Restart section).

The over-current protection fault latch is active during the soft-start cycle. Use 1% resistor for  $R_{ILIM}$ .

### Loop Compensation

The control loop is compensated using a feedback network around the error amplifier. Figure 33 shows a complete Type-3 compensation network. Type-2 compensation eliminates  $R3$  and  $C3$ .

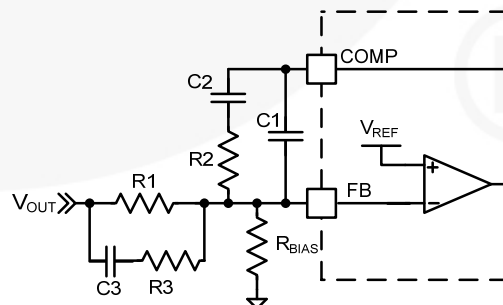


Figure 33. Compensation Network

Since the FAN21SV06 employs summing current-mode architecture, Type-2 compensation can be used for many applications. For applications that require wide loop bandwidth and/or use very low-ESR output capacitors, Type-3 compensation may be required.

$R_{RAMP}$  provides feedforward compensation for changes in  $V_{IN}$ . With a fixed  $R_{RAMP}$  value, the modulator gain increases as  $V_{IN}$  is reduced, which could make it difficult to compensate the loop. For low-input-voltage-range designs (3 V to 8 V),  $R_{RAMP}$  and the compensation component values are going to be different as compared to designs with  $V_{IN}$  between 8 V and 24 V.

### Master/Slave Configuration

When first enabled, the IC determines if it is configured as a master or slave for synchronization, depending on how  $R_T$  is connected.

**Table 2. Master / Slave Configuration**

$R_T$ to:	Master / Slave	CLK Pin
GND	Master	Output
5V_Reg	Slave, free-running	Input

Slaves free-run in the absence of an external clock signal input when  $R_T$  is connected to 5V\_Reg, allowing regulation to be maintained. It is not recommended to leave  $R_T$  open when running in slave mode to avoid noise pick up on the clock pin.

Slave free-running frequency should be set at least 25% lower than the incoming synchronizing pulse frequency. Maximum synchronizing clock frequency is recommended to be below 600 KHz.

### Synchronization

The synchronization method employed by the FAN21SV06 also provides the following features for maximum flexibility.

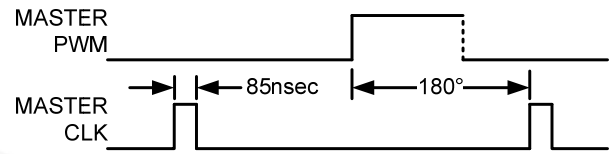
- Synchronization to an external system clock
- Multiple FAN21SV06s can be synchronized to a single master or system clock
- Independently programmable phase adjustment for one or multiple slaves
- Free-running capability in the absence of system clock or, if the master is disabled/failed, the slaves can continue to regulate at a lower frequency

The FAN21SV06 master outputs an 85 ns-wide clock (CLK) signal, delayed 180° from its leading PWM edge. This feature allows out-of-phase operation for the slaves, thereby reducing the input capacitance requirements when more than one converter is operating on the same input supply. The leading SW-node edge is delayed ~40 ns from the rising PWM signal.

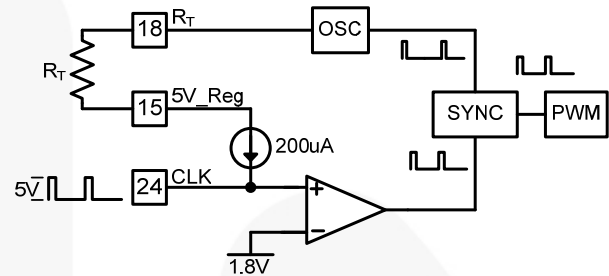
On a slave, synchronization is rising-edge triggered. The CLK input pin has a 1.8 V threshold and a 200  $\mu$ A current source pull-up.

In Master mode, the clock signals go out after power-good signal asserts high. Likewise, in Slave mode synchronization to an external clock signal occurs after

the power-good signal goes high. Until then, the converter operates in free-run mode.

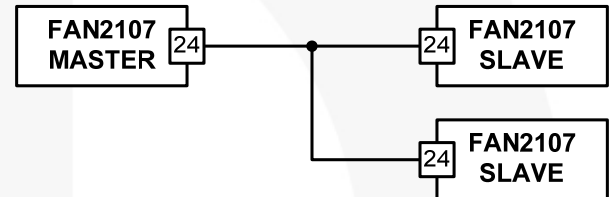


**Figure 34. Synchronization Timing Diagram**



**Figure 35. Slave-CLK-Input Block Diagram**

One or more slaves can be connected directly to a master or system clock to achieve a 180° phase shift.



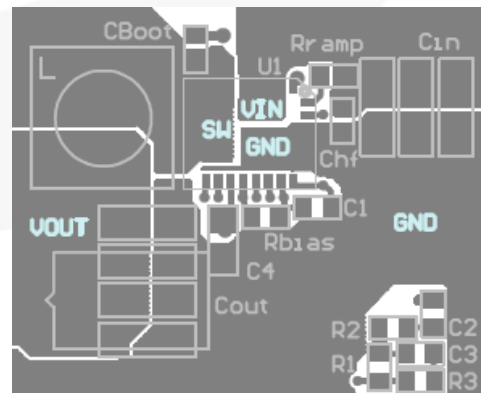
**Figure 36. Slaves with 180° Phase Shift**

Since the synchronizing circuit utilizes a narrow reset pulse, the actual phase delay is slightly more than 180°.

The FAN21SV06 is not intended for use in single-output, multi-phase regulator applications.

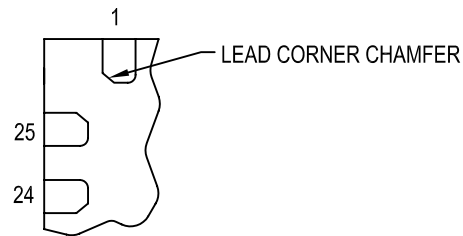
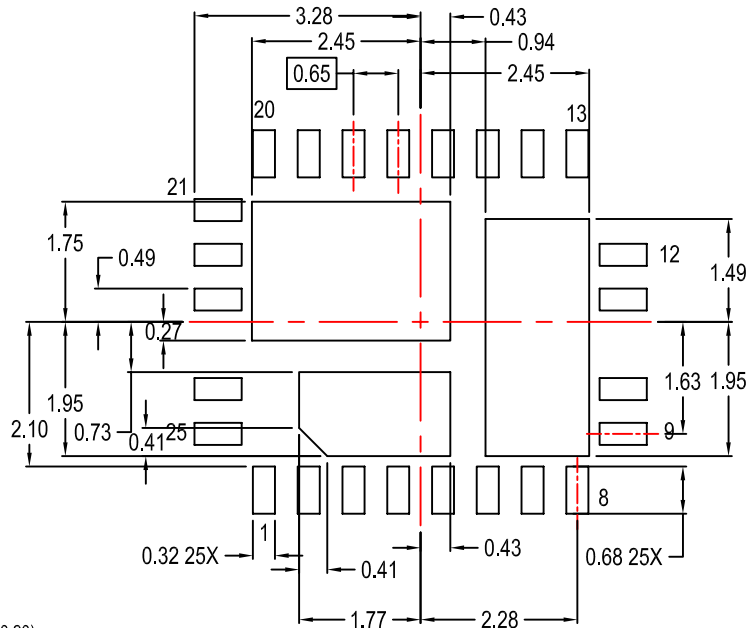
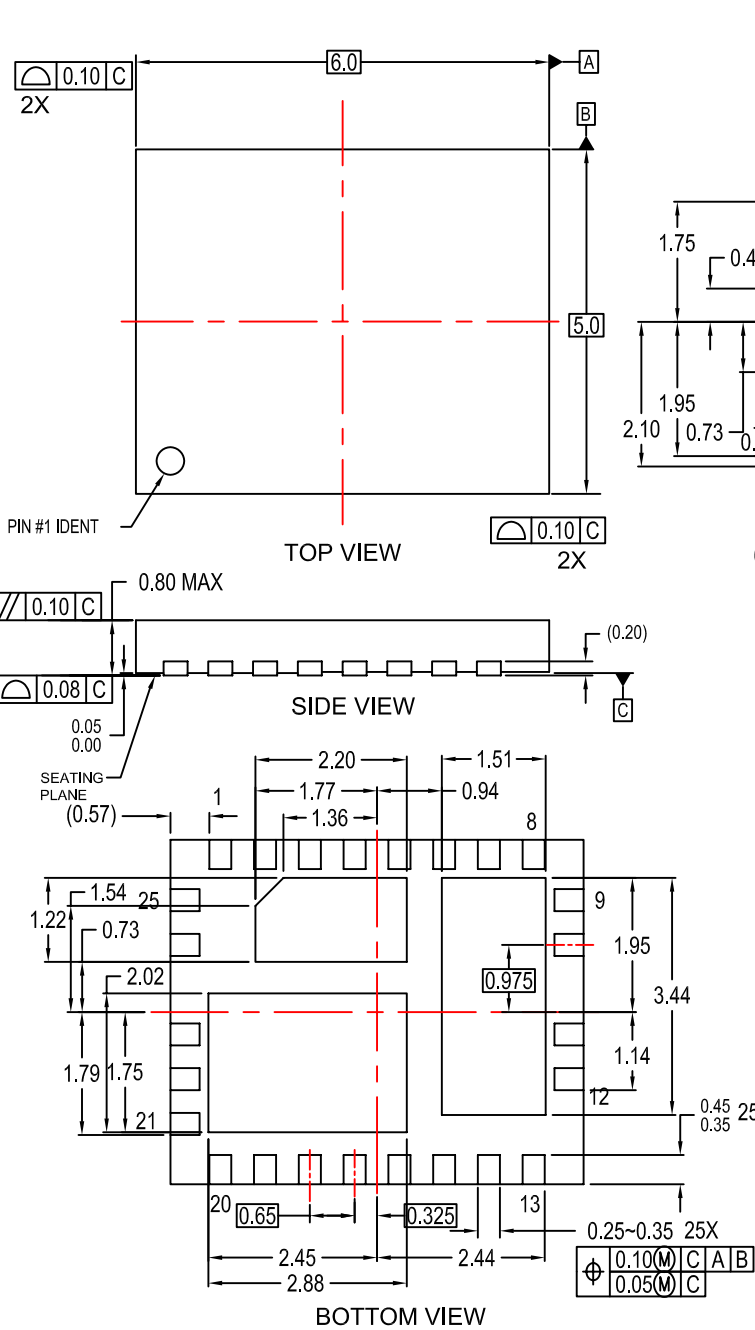
### PCB Layout

Good PCB layout and careful attention to temperature rise is essential for reliable operation of the regulator. Four-layer PCB with 2-ounce copper on the top and bottom side and thermal vias connecting the layers is recommended. Keep power traces wide and short to minimize losses and ringing. Do not connect AGND to PGND below the IC. Connect AGND pin to PGND at the output OR to the PGND plane.



**Figure 37. Recommended PCB Layout**

REVISIONS			
LTR	DESCRIPTION	DATE	BY/SITE
1	RELEASE TO DOCUMENT CONTROL	12-Jul-2007	J.Chan/FSPM
2	ADDED DIMENSIONS TO BOTTOM VIEW AND LANDPATTERN RECOMMENDATION	7-SEPT-2007	H.ALLEN/FSME
3	CHAMFERED LANDPATTERN PAD 1	17-JUN-2009	H.ALLEN/FSME



**NOTES: UNLESS OTHERWISE SPECIFIED**

- A) DIMENSIONS ARE IN MILLIMETERS.
- B) DIMENSIONS AND TOLERANCES PER ASME Y14.5M, 1994
- C) DIMENSIONS DO NOT INCLUDE MOLD FLASH OR BURRS.
- D) DESIGN BASED ON JEDEC MO-220 VARIATION WJHC
- E) TERMINALS ARE SYMMETRICAL AROUND THE X & Y AXIS EXCEPT WHERE DEPOPULATED.
- F) DRAWING FILENAME: MKT-MLP25AREV3

APPROVALS		DATE	Bayan Lepas, FIZ, 11900, Penang, Malaysia.		
DRAWN	H.ALLEN	7-SEPT-07			
DFTG. CHK.	S.MARTIN	7-SEPT-07			
ENGR. CHK.					
25LD, MLP, QUAD, NON-JEDEC, 6x5MM TRIPLE DAP					
		SCALE	SIZE	DRAWING NUMBER	REV
		N/A	N/A	MKT-MLP25A	3
DO NOT SCALE DRAWING				SHEET 1 of 1	



**TRADEMARKS**

The following includes registered and unregistered trademarks and service marks, owned by Fairchild Semiconductor and/or its global subsidiaries, and is not intended to be an exhaustive list of all such trademarks.

- |                          |  |                                       |                  |
|--------------------------|--|---------------------------------------|------------------|
| AccuPower™               | F-PFS™   | OPTOPLANAR®                           | SYSTEM GENERAL®  |
| AttitudeEngine™          | FRFET®   | Power Supply WebDesigner™             | TinyBoost®       |
| Awinda®                  | Global Power Resource <sup>SM</sup>            | PowerTrench®                          | TinyBuck®        |
| AX-CAP®*                 | GreenBridge™                                   | PowerXS™                              | TinyCalc™        |
| BitSiC™                  | Green FPS™                                     | Programmable Active Droop™            | TinyLogic®       |
| Build it Now™            | Green FPS™ e-Series™                           | QFET®                                 | TINYOPTO™        |
| CorePLUS™                | Gmax™  | QS™                                   | TinyPower™       |
| CorePOWER™               | GTO™   | Quiet Series™                         | TinyPWM™         |
| CROSSVOL™                | IntelliMAX™                                    | RapidConfigure™                       | TinyWire™        |
| CTL™                     | ISOPLANAR™                                     | Saving our world, 1mW/W/kW at a time™ | TranSiC™         |
| Current Transfer Logic™  | Making Small Speakers Sound Louder and Better™ | SignalWise™                           | TriFault Detect™ |
| DEUXPEED®                | MegaBuck™                                      | SmartMax™                             | TRUECURRENT®*    |
| Dual Cool™               | MICROCOUPLER™                                  | SMART START™                          | μSerDes™         |
| EcoSPARK®                | MicroFET™                                      | Solutions for Your Success™           | UHC®             |
| EfficientMax™            | MicroPak™                                      | SPM®                                  | Ultra FRFET™     |
| ESBC™                    | MicroPak2™                                     | STEALTH™                              | UniFET™          |
| F <sup>®</sup>           | MillerDrive™                                   | SuperFET®                             | VCX™             |
| Fairchild®               | MotionMax™                                     | SuperSOT™-3                           | VisualMax™       |
| Fairchild Semiconductor® | MotionGrid®                                    | SuperSOT™-6                           | VoltagePlus™     |
| FACT Quiet Series™       | MTi®   | SuperSOT™-8                           | XST™             |
| FACT®                    | MTx®   | SupreMOS®                             | Xsens™           |
| FastvCore™               | MVN®   | SyncFET™                              | 仙童®              |
| FETBench™                | mWSaver®                                       | Sync-Lock™                            |                  |
| FPS™                     | OptoHiT™                                       |                                       |                  |
|                          | OPTOLOGIC®                                     |                                       |                  |

\* Trademarks of System General Corporation, used under license by Fairchild Semiconductor.

**DISCLAIMER**

FAIRCHILD SEMICONDUCTOR RESERVES THE RIGHT TO MAKE CHANGES WITHOUT FURTHER NOTICE TO ANY PRODUCTS HEREIN TO IMPROVE RELIABILITY, FUNCTION, OR DESIGN. TO OBTAIN THE LATEST, MOST UP-TO-DATE DATASHEET AND PRODUCT INFORMATION, VISIT OUR WEBSITE AT [HTTP://WWW.FAIRCHILDSEMI.COM](http://www.fairchildsemi.com). FAIRCHILD DOES NOT ASSUME ANY LIABILITY ARISING OUT OF THE APPLICATION OR USE OF ANY PRODUCT OR CIRCUIT DESCRIBED HEREIN; NEITHER DOES IT CONVEY ANY LICENSE UNDER ITS PATENT RIGHTS, NOR THE RIGHTS OF OTHERS. THESE SPECIFICATIONS DO NOT EXPAND THE TERMS OF FAIRCHILD'S WORLDWIDE TERMS AND CONDITIONS, SPECIFICALLY THE WARRANTY THEREIN, WHICH COVERS THESE PRODUCTS.

**AUTHORIZED USE**

Unless otherwise specified in this data sheet, this product is a standard commercial product and is not intended for use in applications that require extraordinary levels of quality and reliability. This product may not be used in the following applications, unless specifically approved in writing by a Fairchild officer: (1) automotive or other transportation, (2) military/aerospace, (3) any safety critical application – including life critical medical equipment – where the failure of the Fairchild product reasonably would be expected to result in personal injury, death or property damage. Customer's use of this product is subject to agreement of this Authorized Use policy. In the event of an unauthorized use of Fairchild's product, Fairchild accepts no liability in the event of product failure. In other respects, this product shall be subject to Fairchild's Worldwide Terms and Conditions of Sale, unless a separate agreement has been signed by both Parties.

**ANTI-COUNTERFEITING POLICY**

Fairchild Semiconductor Corporation's Anti-Counterfeiting Policy. Fairchild's Anti-Counterfeiting Policy is also stated on our external website, [www.fairchildsemi.com](http://www.fairchildsemi.com), under Terms of Use

Counterfeiting of semiconductor parts is a growing problem in the industry. All manufacturers of semiconductor products are experiencing counterfeiting of their parts. Customers who inadvertently purchase counterfeit parts experience many problems such as loss of brand reputation, substandard performance, failed applications, and increased cost of production and manufacturing delays. Fairchild is taking strong measures to protect ourselves and our customers from the proliferation of counterfeit parts. Fairchild strongly encourages customers to purchase Fairchild parts either directly from Fairchild or from Authorized Fairchild Distributors who are listed by country on our web page cited above. Products customers buy either from Fairchild directly or from Authorized Fairchild Distributors are genuine parts, have full traceability, meet Fairchild's quality standards for handling and storage and provide access to Fairchild's full range of up-to-date technical and product information. Fairchild and our Authorized Distributors will stand behind all warranties and will appropriately address any warranty issues that may arise. Fairchild will not provide any warranty coverage or other assistance for parts bought from Unauthorized Sources. Fairchild is committed to combat this global problem and encourage our customers to do their part in stopping this practice by buying direct or from authorized distributors.

**PRODUCT STATUS DEFINITIONS**

**Definition of Terms**

Datasheet Identification	Product Status	Definition
Advance Information	Formative / In Design	Datasheet contains the design specifications for product development. Specifications may change in any manner without notice.
Preliminary	First Production	Datasheet contains preliminary data; supplementary data will be published at a later date. Fairchild Semiconductor reserves the right to make changes at any time without notice to improve design.
No Identification Needed	Full Production	Datasheet contains final specifications. Fairchild Semiconductor reserves the right to make changes at any time without notice to improve the design.
Obsolete	Not In Production	Datasheet contains specifications on a product that is discontinued by Fairchild Semiconductor. The datasheet is for reference information only.

Rev. I77