



# FPF2165R

## Full Function Load Switch with Adjustable Current Limit

### Features

- 1.8 to 5.5 V Input Voltage Range
- Controlled Turn-On
- 0.15-1.5 A Adjustable Current Limit
- $\pm 10\%$  Current Limit Accuracy vs. Temperature
- Under-Voltage Lockout (UVLO)
- Thermal Shutdown
- $< 2 \mu\text{A}$  Shutdown Current
- Fast Current limit Response Time
  - 5  $\mu\text{s}$  to Moderate Over Currents
  - 30 ns to Hard Shorts
- Reverse Current Blocking
- RoHS Compliant

### Applications

- PDAs
- Cell Phones
- GPS Devices
- MP3 Players
- Digital Cameras
- Peripheral Ports
- Hot Swap Supplies

### Related Resources

- [FPF2165R Product Information](#)

### Description

The FPF2165R is a load switch which provides full protection to systems and loads which may encounter large current conditions. The device contains a  $0.12 \Omega$  current-limited Pchannel MOSFET which can operate over an input voltage range of 1.8-5.5 V. Internally, current is prevented from flowing when the MOSFET is off and the output voltage is higher than the input voltage. Switch control is by a logic input (ON) capable of interfacing directly with low-voltage control signals. The FPF2165R contains thermal shutdown protection, which shuts off the switch to prevent damage to the part when a continuous over-current condition causes excessive heating.

When the switch current reaches the current limit, the part operates in a Constant-Current (CC) mode to prohibit excessive currents from causing damage. The FPF2165R does not turn off after a current limit fault; it remains in the constant current mode indefinitely. The minimum current limit is 150 mA.

The FPF2165R is available in a space-saving 6-pin 2 mm x 2 mm Molded Leadless Package (MLP).



Figure 1. 2 mm x 2 mm Molded Leadless Package (MLP)

### Ordering Information

Part Number	Current Limit [mA]	Current Limit Blanking Time [ms]	Auto Restart Time [ms]	On Pin Activity	Top Mark
FPF2165R	150-1500	0	NA	Active HI	65R

Typical Application

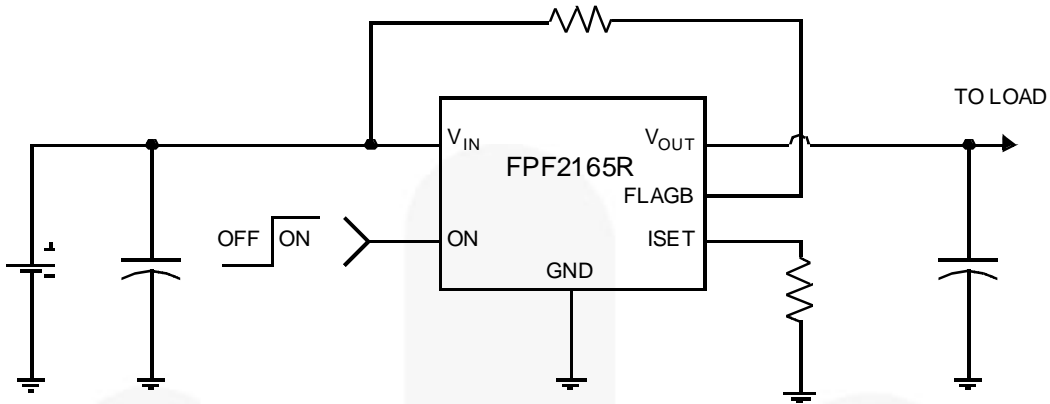

Figure 2. Typical Application

Block Diagram

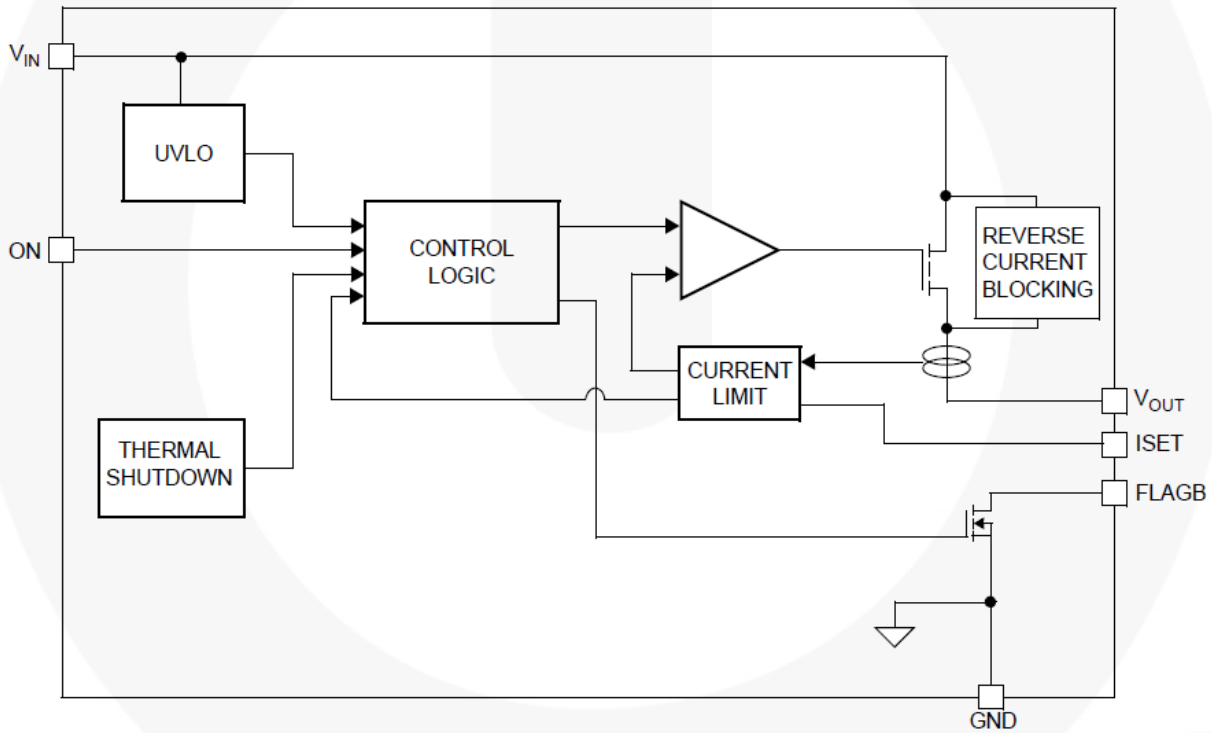

Figure 3. Block Diagram

## Pin Configuration

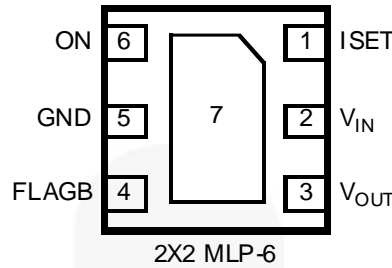

Figure 4. Pin Assignment (Top Through View)

## Pin Descriptions

Name	Type	Description
1	ISET	Current Limit Set Input: A resistor from ISET to ground sets the current limit for the switch.
2	$V_{IN}$	Supply Input: Input to the power switch and the supply voltage For the IC
3	$V_{OUT}$	Switch Output: Output of the power switch
4	FLAGB	Fault Output: Active LO, open drain output which indicates an over-current supply under-voltage or over-temperature state.
5, 7	GND	Ground
6	ON	ON Control Input

## Absolute Maximum Ratings

Stresses exceeding the absolute maximum ratings may damage the device. The device may not function or be operable above the recommended operating conditions and stressing the parts to these levels is not recommended. In addition, extended exposure to stresses above the recommended operating conditions may affect device reliability. The absolute maximum ratings are stress ratings only.

Symbol	Parameter		Min.	Max.	Unit	
$V_{IN}$	$V_{IN}$ , $V_{OUT}$ , ON, FLAGB, ISET to GND		-0.3	6.0	V	
$P_D$	Power Dissipation			1.2	W	
$T_{STG}$	Operating and Storage Junction Temperature		-65	150	°C	
$\Theta_{JA}$	Thermal Resistance, Junction to Ambient			86	°C/W	
ESD	Electrostatic Discharge Capability	Human Body Model; JEDEC A1141	4000		V	
		Charged Device Model; JEDEC C101C	2000			
		Machine Model; JEDEC A115	400			
		IEC 61000-4-2	Air Discharge	15000		
			Contact Discharge	8000		

## Recommended Operating Conditions

The Recommended Operating Conditions table defines the conditions for actual device operation. Recommended operating conditions are specified to ensure optimal performance. Fairchild does not recommend exceeding them or designing to Absolute Maximum Ratings.

Symbol	Parameter	Min.	Max.	Unit
$V_{IN}$	Input Voltage	1.8	5.5	V
$T_A$	Ambient Operating Temperature	-40	85	°C

## Electrical Characteristics

$V_{IN} = 1.8$  to  $5.5$  V,  $T_A = -40$  to  $+85^\circ\text{C}$  unless otherwise noted. Typical values are at  $V_{IN} = 3.3$  V and  $T_A = 25^\circ\text{C}$ .

Symbol	Parameter	Conditions	Min.	Typ.	Max.	Unit	
<b>Basic Operation</b>							
$V_{IN}$	Operating Voltage		1.8		5.5	V	
$I_Q$	Quiescent Current	$I_{OUT} = 1$ mA	$V_{IN} = 1.8$ V		63	100	$\mu\text{A}$
			$V_{IN} = 3.3$ V		68		
			$V_{IN} = 5.5$ V		77	120	
$R_{ON}$	On Resistance	$V_{IN} = 3.3$ V, $I_{OUT} = 200$ mA, $T_A = 25^\circ\text{C}$		120	160	m $\Omega$	
		$V_{IN} = 3.3$ V, $I_{OUT} = 200$ mA, $T_A = 85^\circ\text{C}$		135	180		
		$V_{IN} = 3.3$ V, $I_{OUT} = 200$ mA, $T_A = -40^\circ\text{C}$ to $+85^\circ\text{C}$	65		180		
		$V_{IN} = 5$ V, $I_{OUT} = 200$ mA, $T_A = 25^\circ\text{C}$		95	124		
		$V_{IN} = 5$ V, $I_{OUT} = 200$ mA, $T_A = 85^\circ\text{C}$		110	143		
		$V_{IN} = 5$ V, $I_{OUT} = 200$ mA, $T_A = -40^\circ\text{C}$ to $+85^\circ\text{C}$	58		143		
$V_{IH}$	ON Input Logic High Voltage (ON)	$V_{IN} = 1.8$ V	0.8			V	
		$V_{IN} = 5.5$ V	1.4				
$V_{IL}$	ON Input Logic Low Voltage	$V_{IN} = 1.8$ V			0.5	V	
		$V_{IN} = 5.5$ V			1		
	ON Input Leakage	$V_{ON} = V_{IN}$ or GND	-1		1	$\mu\text{A}$	
	$V_{IN}$ Shutdown Current	$V_{ON} = 0$ V, $V_{IN} = 5.5$ V, $V_{OUT} = \text{Short to GND}$	-2		2	$\mu\text{A}$	
	FLAGB Output Logic Low Voltage	$V_{IN} = 5$ V, $I_{SINK} = 10$ mA		0.05	0.20	V	
		$V_{IN} = 1.8$ V, $I_{SINK} = 10$ mA		0.12	0.30		
	FLAGB Output High Leakage Current	$V_{IN} = 5$ V, Switch On			1	$\mu\text{A}$	
<b>Reverse Block</b>							
	$V_{OUT}$ Shutdown Current	$V_{ON} = 0$ V, $V_{OUT} = 5.5$ V, $V_{IN} = \text{Short to GND}$	-2		2	$\mu\text{A}$	
<b>Protections</b>							
$I_{LIM}$	Current Limit	$V_{IN} = 3.3$ V, $V_{OUT} = 3.0$ V, $R_{SET} = 1840\Omega$	135	150	165	mA	
		$V_{IN} = 3.3$ V, $V_{OUT} = 3.0$ V, $R_{SET} = 361\Omega$	720	800	880		
		$V_{IN} = 3.3$ V, $V_{OUT} = 3.0$ V, $R_{SET} = 196\Omega$	1350	1500	1650		
	Thermal Shutdown	Shutdown Threshold		140		$^\circ\text{C}$	
		Return from Shutdown		130			
		Hysteresis		10			
UVLO	Under-Voltage Shutdown	$V_{IN}$ Increasing	1.55	1.65	1.75	V	
	Under-Voltage Shutdown Hysteresis			50		mV	
<b>Dynamic</b>							
$t_{DON}$	Delay On Time	$R_L = 500\Omega$ , $C_L = 0.1\mu\text{F}$		25		$\mu\text{s}$	
$t_{DOFF}$	Delay Off Time	$R_L = 500\Omega$ , $C_L = 0.1\mu\text{F}$		45		$\mu\text{s}$	
$t_{RISE}$	$V_{OUT}$ Rise Time	$R_L = 500\Omega$ , $C_L = 0.1\mu\text{F}$		10		$\mu\text{s}$	
$t_{FALL}$	$V_{OUT}$ Fall Time	$R_L = 500\Omega$ , $C_L = 0.1\mu\text{F}$		110		$\mu\text{s}$	
	Short-Circuit Response Time	$V_{IN} = V_{OUT} = 3.3$ V, Moderate Over-Current Condition		5		$\mu\text{s}$	
		$V_{IN} = V_{OUT} = 3.3$ V, Hard Short		30		ns	

### Note:

- Package power dissipation on 1square inch pad, 2 oz copper board.

## Typical Performance Characteristics

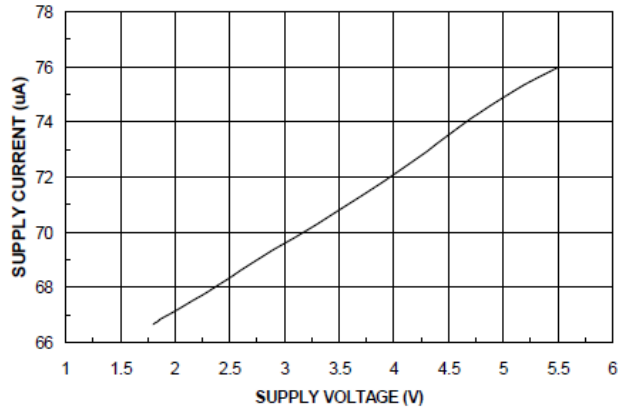

Figure 5. Quiescent Current vs. Input Voltage

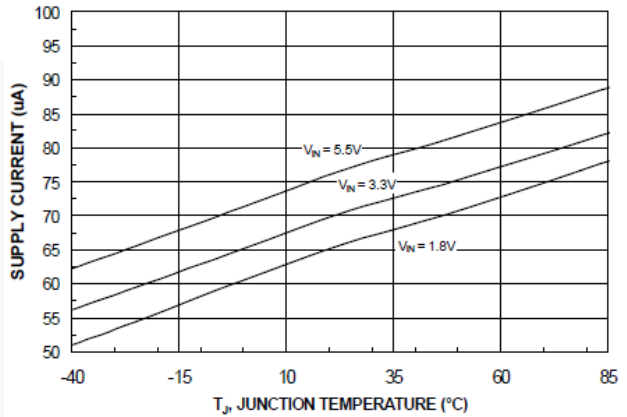

Figure 6. Quiescent Current vs. Temperature

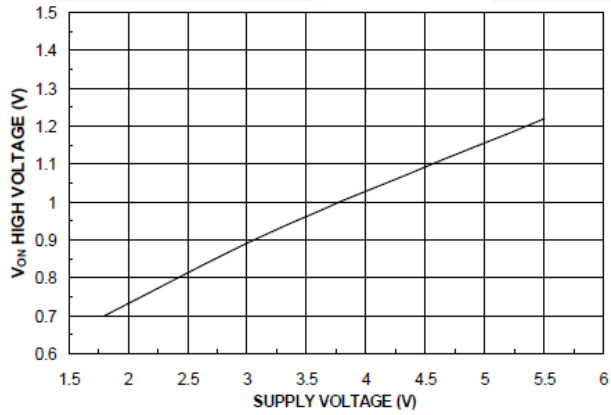

Figure 7.  $V_{ON}$  High Voltage vs. Input Voltage

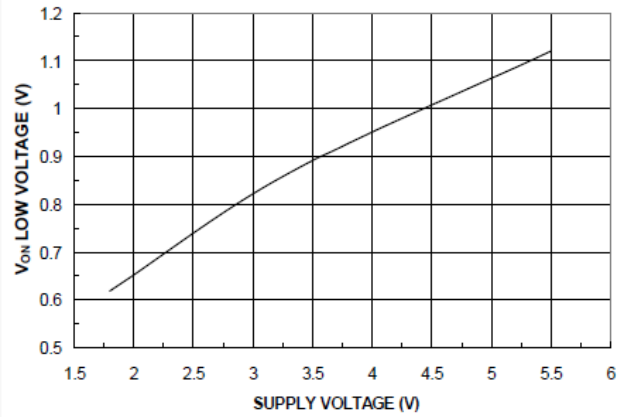

Figure 8.  $V_{ON}$  Low Voltage vs. Input Voltage

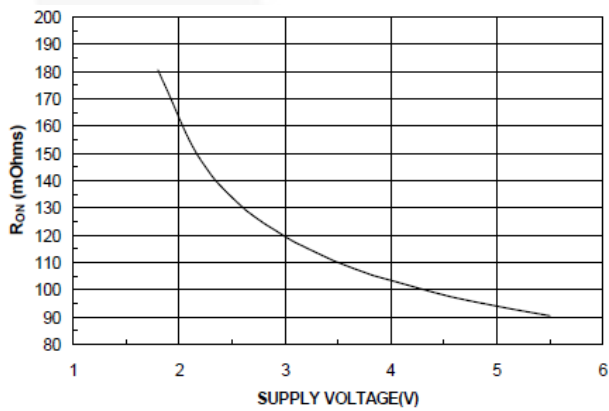

Figure 9.  $R_{ON}$  vs.  $V_{IN}$

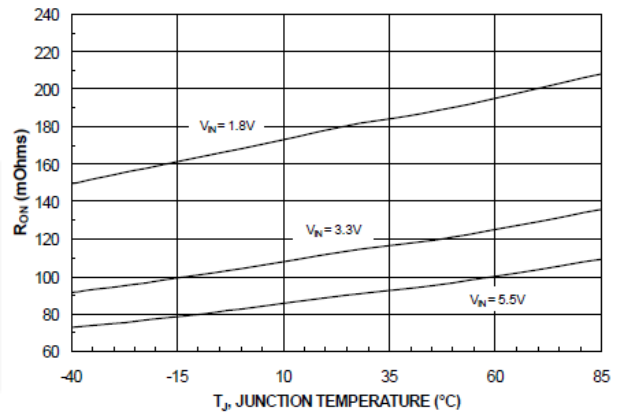

Figure 10.  $R_{ON}$  vs. Temperature

### Typical Performance Characteristics

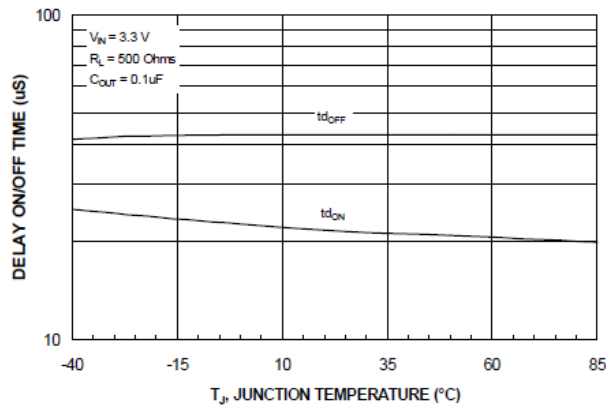

Figure 11.  $t_{ON} / t_{OFF}$  vs. Temperature

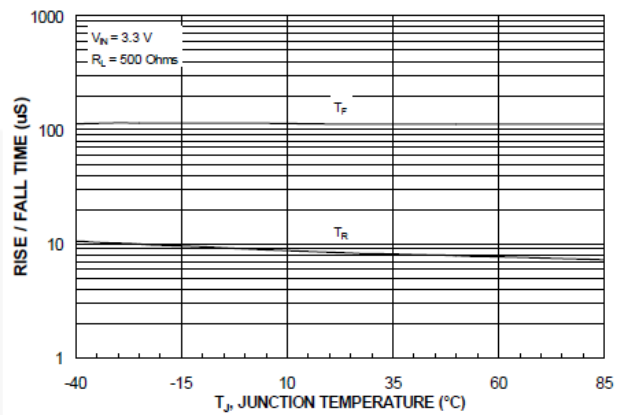

Figure 12.  $T_{RISE} / T_{FALL}$  vs. Temperature

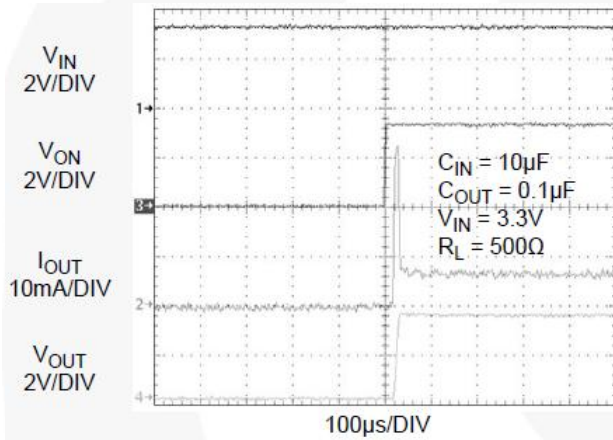

Figure 13.  $t_{ON}$  Response

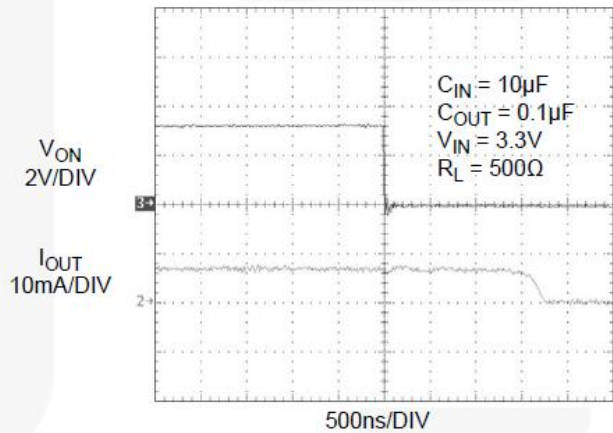

Figure 14.  $t_{OFF}$  Response

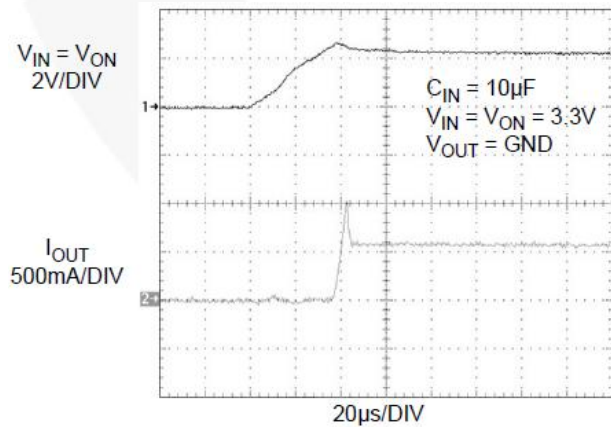

Figure 15. Current Limit Response Time (Switch Powered into Short)

## Description of Operation

The FPF2165R is a current limited switch that protects systems and loads which can be damaged or disrupted by the application of high currents. The core of each device is a 0.12  $\Omega$  P-channel MOSFET and a controller capable of functioning over a wide input operating range of 1.8-5.5 V. The controller protects against system malfunctions through current limiting, under-voltage lockout and thermal shutdown. The current limit is adjustable from 0.15 A to 1.5 A through the selection of an external resistor.

### On/Off Control

The ON pin controls the state of the switch. When ON is high, the switch is in the On state. Activating ON continuously holds the switch in the On state so long as there is no fault. An under-voltage on  $V_{IN}$  or a junction temperature in excess of 140°C overrides the ON control to turn off the switch. The FPF2165R does not turn off in response to an over-current condition but instead remains operating in a constant current mode so long as ON is active and the thermal shutdown or under-voltage lockout have not activated.

The ON pin control voltage and  $V_{IN}$  pin have independent recommended operating ranges. The ON pin voltage can be driven by a voltage level higher than the input voltage.

### Fault Reporting

Upon the detection of an over-current, an input under-voltage, or an over-temperature condition, the FLAGB signals the fault mode by activating LOW. With the FPF2165R, FLAGB is LOW during the faults and immediately returns HI at the end of the fault condition. FLAGB is an open-drain MOSFET which requires a pull-up resistor between  $V_{IN}$  and FLAGB. During shutdown, the pull-down on FLAGB is disabled to reduce current draw from the supply.

### Current Limiting

The current limit ensures that the current through the switch doesn't exceed a maximum value while not limiting at less than a minimum value. The current at which the parts will limit is adjustable through the selection of an external resistor connected to ISET. Information for selecting the resistor is found in the Application Info section. The FPF2165R has no current limit blanking period so it remains in a constant-current

state until the ON pin is deactivated or the thermal shutdown turns-off the switch.

For preventing the switch from large power dissipation during heavy load a short circuit detection feature is introduced. Short circuit condition is detected by observing the output voltage. The switch is put into short circuit current limiting mode if the switch is loaded with a heavy load. When the output voltage drops below  $V_{SCTH}$ , short circuit detection threshold voltage, the current limit value re-conditioned and short circuit current limit value is decreased to 62.5% of the current limit value. This keeps the power dissipation of the part below a certain limit even at dead short conditions at 5.5 V input voltage. The  $V_{SCTH}$  value is set to be 1 V. At around 1.1 V of output voltage the switch is removed from short circuit current limiting mode and the current limit is set to the current limit value.

### Under-Voltage Lockout

The under-voltage lockout turns-off the switch if the input voltage drops below the under-voltage lockout threshold. With the ON pin active the input voltage rising above the under-voltage lockout threshold causes a controlled turn-on of the switch which limits current over-shoots.

### Reverse Current Blocking

The FPF2165R family has a Reverse Current Blocking feature that protects input source against current flow from output to input. For a standard USB power design, this is an important feature that protects the USB host from being damaged due to reverse current flow on  $V_{BUS}$ . The reverse-current blocking feature is active when the load switch is turned off.

If ON pin is LOW and output voltage becomes greater than input voltage, no current can flow from the output to the input. FLAGB operation is independent of the reverse current blocking and does not report a fault condition if this feature is activated.

### Thermal Shutdown

The thermal shutdown protects the die from internally or externally generated excessive temperatures. During an over-temperature condition the FLAGB is activated and the switch is turned-off. The switch automatically turns-on again if temperature of the die drops below the threshold temperature.

## Applications Information

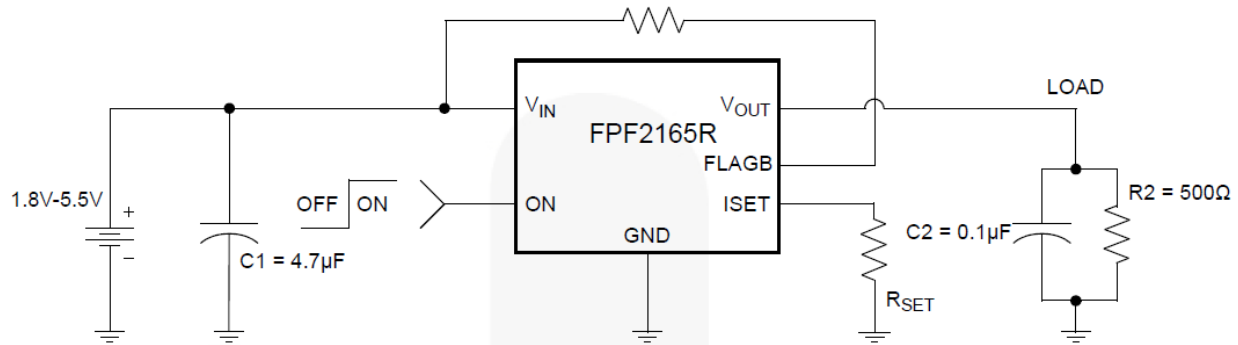

Figure 16. Typical Application

### Setting Current Limit

The PPF2165R has a current limit which is set with an external resistor connected between ISET and GND. This resistor is selected by using equation (1),

$$I_{LIM} = 340.1 \times R_{SET} - 1.0278 \quad (1)$$

Table 1 can be used to select  $R_{SET}$ . A typical application would be the 500 mA current that is required by a single USB port. Using Table 1 an appropriate selection for the RSET resistor would be 570  $\Omega$ .

Table 1. Current Limit Various  $R_{SET}$  Values

$R_{SET}$ [ $\Omega$ ]	Min. Current Limit [mA]	Typ. Current Limit [mA]	Max. Current Limit [mA]
1840	135	150	165
1391	180	200	220
937	270	300	330
708	360	400	440
632	405	450	495
570	450	500	550
478	540	600	660
411	630	700	770
361	720	800	880
322	810	900	990
290	900	1000	1100
265	990	1100	1210
243	1080	1200	1320
225	1170	1300	1430
209	1260	1400	1540
196	1350	1500	1650

### Input Capacitor

To limit the voltage drop on the input supply caused by transient in-rush currents when the switch is turned on into a discharged load capacitor or a short-circuit; a capacitor needs to be placed between  $V_{IN}$  and GND. A 4.7  $\mu\text{F}$  ceramic capacitor,  $C_{IN}$ , must be placed close to the  $V_{IN}$  pin. A higher value of  $C_{IN}$  can be used to further reduce the voltage drop experienced as the switch is turned on into a large capacitive load.

### Output Capacitor

A 0.1  $\mu\text{F}$  capacitor  $C_{OUT}$ , should be placed between  $V_{OUT}$  and GND. This capacitor prevents parasitic board inductances from forcing  $V_{OUT}$  below GND when the switch turns-off.

### Power Dissipation

During normal operation as a switch, the power dissipated in the part depends upon the level at which the current limit is set. The maximum allowed setting for the current limit is 0.77 A and this results in a power dissipation of,

$$P = (I_{LIM})^2 \times R_{DS} = (0.77)^2 \times 0.12 = 71.148\text{mW} \quad (2)$$

If the part goes into current limit the maximum power dissipation occurs when the output is shorted to ground. This is more power than the package can dissipate, but the thermal shutdown of the part activates to protect the part from damage due to excessive heating. A short on the output causes the part to operate in a constant-current state dissipating a worst case power of,

$$P(\text{max}) = V_{IN}(\text{max}) \times I_{LIM}(\text{max}) \\ = 5.5 \times 0.77 = 4.235\text{W} \quad (3)$$

This large amount of power activates the thermal shutdown and the part cycles in and out of thermal shutdown so long as the ON pin is active and the short is present.

## Board Layout

For best performance, all traces should be as short as possible. To be most effective, the input and output capacitors should be placed close to the device to minimize the effects that parasitic trace inductances may have on normal and short-circuit operation. Using wide traces for  $V_{IN}$ ,  $V_{OUT}$  and GND helps minimize parasitic electrical effects along with minimizing the case-to-ambient thermal impedance.

The middle pad (pin 7) should be connected to the GND plate of PCB for improving thermal performance of the load switch. An improper layout could result higher junction temperature and triggering the thermal shutdown protection feature. This concern applies when the switch is set at higher current limit value and an over-current condition occurs. In this case power dissipation of the switch ( $P_D = (V_{IN} - V_{OUT}) \times I_{LIM(max)}$ ) could exceed the maximum absolute power dissipation of 1.2 W.

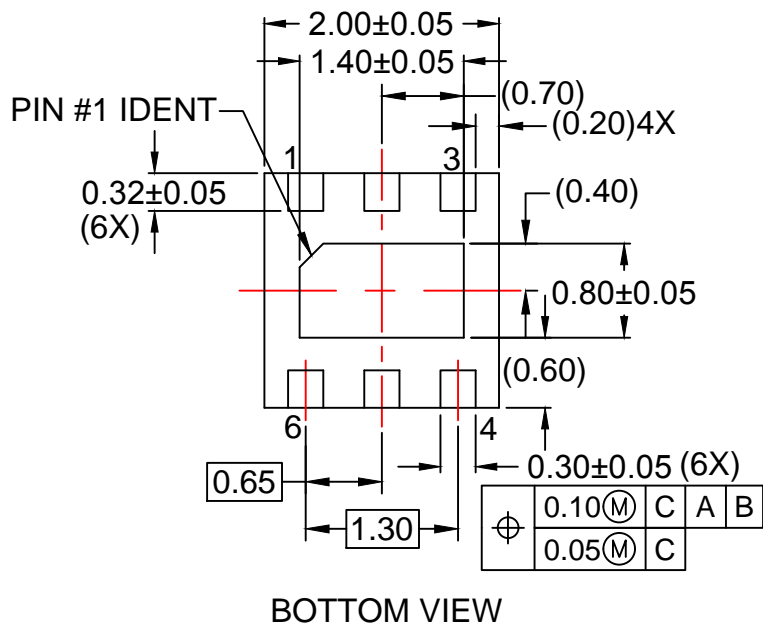
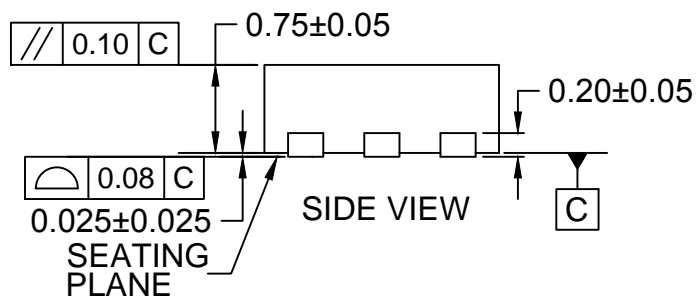
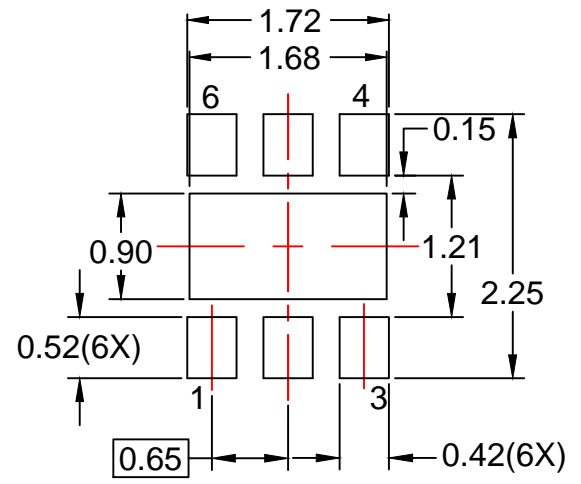
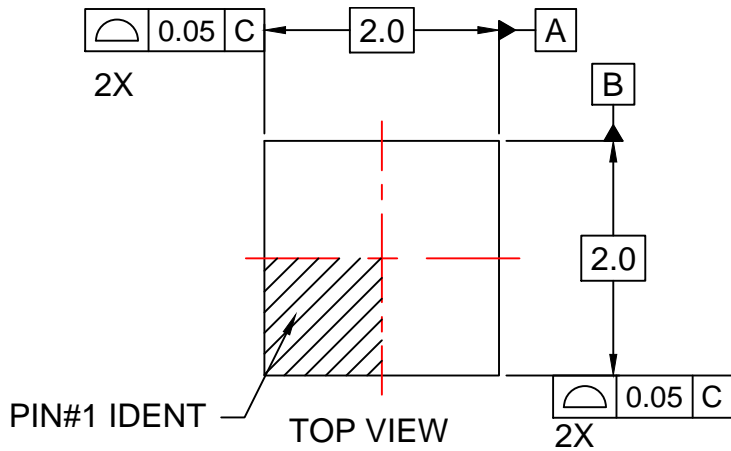

NOTES:

- A. PACKAGE DOES NOT FULLY CONFORM TO JEDEC MO-229 REGISTRATION
- B. DIMENSIONS ARE IN MILLIMETERS.
- C. DIMENSIONS AND TOLERANCES PER ASME Y14.5M, 2009.
- D. LAND PATTERN RECOMMENDATION IS EXISTING INDUSTRY LAND PATTERN.
- E. DRAWING FILENAME: MKT-MLP06Krev5.





**TRADEMARKS**

The following includes registered and unregistered trademarks and service marks, owned by Fairchild Semiconductor and/or its global subsidiaries, and is not intended to be an exhaustive list of all such trademarks.

- |                          |  |                                       |                  |
|--------------------------|--|---------------------------------------|------------------|
| AccuPower™               | F-PFS™   | OPTOPLANAR®                           | SYSTEM GENERAL®  |
| AttitudeEngine™          | FRFET®   | Power Supply WebDesigner™             | TinyBoost®       |
| Awinda®                  | Global Power Resource <sup>SM</sup>            | PowerTrench®                          | TinyBuck®        |
| AX-CAP®*                 | GreenBridge™                                   | PowerXS™                              | TinyCalc™        |
| BitSiC™                  | Green FPS™                                     | Programmable Active Droop™            | TinyLogic®       |
| Build it Now™            | Green FPS™ e-Series™                           | QFET®                                 | TINYOPTO™        |
| CorePLUS™                | Gmax™  | QS™                                   | TinyPower™       |
| CorePOWER™               | GTO™   | Quiet Series™                         | TinyPWM™         |
| CROSSVOL™                | IntelliMAX™                                    | RapidConfigure™                       | TinyWire™        |
| CTL™                     | ISOPLANAR™                                     | Saving our world, 1mW/W/kW at a time™ | TranSiC™         |
| Current Transfer Logic™  | Making Small Speakers Sound Louder and Better™ | SignalWise™                           | TriFault Detect™ |
| DEUXPEED®                | MegaBuck™                                      | SmartMax™                             | TRUECURRENT®*    |
| Dual Cool™               | MICROCOUPLER™                                  | SMART START™                          | μSerDes™         |
| EcoSPARK®                | MicroFET™                                      | Solutions for Your Success™           | UHC®             |
| EfficientMax™            | MicroPak™                                      | SPM®                                  | Ultra FRFET™     |
| ESBC™                    | MicroPak2™                                     | STEALTH™                              | UniFET™          |
| F <sup>®</sup>           | MillerDrive™                                   | SuperFET®                             | Vcx™             |
| Fairchild®               | MotionMax™                                     | SuperSOT™-3                           | VisualMax™       |
| Fairchild Semiconductor® | MotionGrid®                                    | SuperSOT™-6                           | VoltagePlus™     |
| FACT Quiet Series™       | MTi®   | SuperSOT™-8                           | XST™             |
| FACT®                    | MTx®   | SupreMOS®                             | Xsens™           |
| FastvCore™               | MVN®   | SyncFET™                              | 仙童®              |
| FETBench™                | mWSaver®                                       | Sync-Lock™                            |                  |
| FPS™                     | OptoHiT™                                       |                                       |                  |
|                          | OPTOLOGIC®                                     |                                       |                  |

\* Trademarks of System General Corporation, used under license by Fairchild Semiconductor.

**DISCLAIMER**

FAIRCHILD SEMICONDUCTOR RESERVES THE RIGHT TO MAKE CHANGES WITHOUT FURTHER NOTICE TO ANY PRODUCTS HEREIN TO IMPROVE RELIABILITY, FUNCTION, OR DESIGN. TO OBTAIN THE LATEST, MOST UP-TO-DATE DATASHEET AND PRODUCT INFORMATION, VISIT OUR WEBSITE AT [HTTP://WWW.FAIRCHILDSEMI.COM](http://www.fairchildsemi.com). FAIRCHILD DOES NOT ASSUME ANY LIABILITY ARISING OUT OF THE APPLICATION OR USE OF ANY PRODUCT OR CIRCUIT DESCRIBED HEREIN; NEITHER DOES IT CONVEY ANY LICENSE UNDER ITS PATENT RIGHTS, NOR THE RIGHTS OF OTHERS. THESE SPECIFICATIONS DO NOT EXPAND THE TERMS OF FAIRCHILD'S WORLDWIDE TERMS AND CONDITIONS, SPECIFICALLY THE WARRANTY THEREIN, WHICH COVERS THESE PRODUCTS.

**AUTHORIZED USE**

Unless otherwise specified in this data sheet, this product is a standard commercial product and is not intended for use in applications that require extraordinary levels of quality and reliability. This product may not be used in the following applications, unless specifically approved in writing by a Fairchild officer: (1) automotive or other transportation, (2) military/aerospace, (3) any safety critical application – including life critical medical equipment – where the failure of the Fairchild product reasonably would be expected to result in personal injury, death or property damage. Customer's use of this product is subject to agreement of this Authorized Use policy. In the event of an unauthorized use of Fairchild's product, Fairchild accepts no liability in the event of product failure. In other respects, this product shall be subject to Fairchild's Worldwide Terms and Conditions of Sale, unless a separate agreement has been signed by both Parties.

**ANTI-COUNTERFEITING POLICY**

Fairchild Semiconductor Corporation's Anti-Counterfeiting Policy. Fairchild's Anti-Counterfeiting Policy is also stated on our external website, [www.fairchildsemi.com](http://www.fairchildsemi.com), under Terms of Use

Counterfeiting of semiconductor parts is a growing problem in the industry. All manufacturers of semiconductor products are experiencing counterfeiting of their parts. Customers who inadvertently purchase counterfeit parts experience many problems such as loss of brand reputation, substandard performance, failed applications, and increased cost of production and manufacturing delays. Fairchild is taking strong measures to protect ourselves and our customers from the proliferation of counterfeit parts. Fairchild strongly encourages customers to purchase Fairchild parts either directly from Fairchild or from Authorized Fairchild Distributors who are listed by country on our web page cited above. Products customers buy either from Fairchild directly or from Authorized Fairchild Distributors are genuine parts, have full traceability, meet Fairchild's quality standards for handling and storage and provide access to Fairchild's full range of up-to-date technical and product information. Fairchild and our Authorized Distributors will stand behind all warranties and will appropriately address any warranty issues that may arise. Fairchild will not provide any warranty coverage or other assistance for parts bought from Unauthorized Sources. Fairchild is committed to combat this global problem and encourage our customers to do their part in stopping this practice by buying direct or from authorized distributors.

**PRODUCT STATUS DEFINITIONS**

**Definition of Terms**

Datasheet Identification	Product Status	Definition
Advance Information	Formative / In Design	Datasheet contains the design specifications for product development. Specifications may change in any manner without notice.
Preliminary	First Production	Datasheet contains preliminary data; supplementary data will be published at a later date. Fairchild Semiconductor reserves the right to make changes at any time without notice to improve design.
No Identification Needed	Full Production	Datasheet contains final specifications. Fairchild Semiconductor reserves the right to make changes at any time without notice to improve the design.
Obsolete	Not In Production	Datasheet contains specifications on a product that is discontinued by Fairchild Semiconductor. The datasheet is for reference information only.

Rev. I77