

### GENERAL DESCRIPTION

The 8304 is a low skew, 1-to-4 Fanout Buffer. The 8304 is characterized at full 3.3V for input ( $V_{DD}$ ), and mixed 3.3V and 2.5V for output operating supply modes ( $V_{DDO}$ ). Guaranteed output and part-to-part skew characteristics make the 8304 ideal for those clock distribution applications demanding well defined performance and repeatability.

### FEATURES

- Four LVCMOS / LVTTL outputs
- LVCMOS / LVTTL clock input
- CLK can accept the following input levels: LVCMOS, LVTTL
- Maximum output frequency: 200MHz
- Additive phase jitter, RMS: 0.173ps (typical) @ 3.3V
- Output skew: 45ps (maximum) @ 3.3V
- Part-to-part skew: 500ps (maximum)
- Small 8 lead SOIC package saves board space
- 3.3V input, outputs may be either 3.3V or 2.5V supply modes
- 0°C to 70°C ambient operating temperature
- Available in lead-free (RoHS 6) compliant package

### BLOCK DIAGRAM

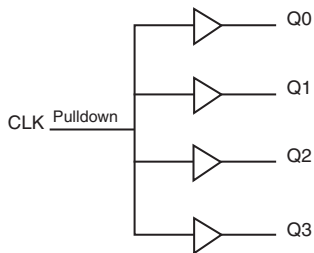

### PIN ASSIGNMENT

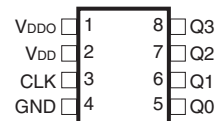

**8304**  
**8-Lead SOIC**  
 3.9mm x 4.9mm, x 1.375mm package body  
**M Package**  
 Top View

TABLE 1. PIN DESCRIPTIONS

Number	Name	Type		Description
1	V <sub>DDO</sub>	Power		Output supply pin.
2	V <sub>DD</sub>	Power		Positive supply pin.
3	CLK	Input	Pulldown	LVC MOS / LVTTTL clock input.
4	GND	Power		Power supply ground.
5	Q0	Output		Single clock output. LVC MOS / LVTTTL interface levels.
6	Q1	Output		Single clock output. LVC MOS / LVTTTL interface levels.
7	Q2	Output		Single clock output. LVC MOS / LVTTTL interface levels.
8	Q3	Output		Single clock output. LVC MOS / LVTTTL interface levels.

NOTE: *Pulldown* refers to internal input resistors. See Table 2, Pin Characteristics, for typical values.

TABLE 2. PIN CHARACTERISTICS

Symbol	Parameter	Test Conditions	Minimum	Typical	Maximum	Units
C <sub>IN</sub>	Input Capacitance			4		pF
C <sub>PD</sub>	Power Dissipation Capacitance (per output)	V <sub>DD</sub> , V <sub>DDO</sub> = 3.465V			15	pF
R <sub>PULLDOWN</sub>	Input Pulldown Resistor			51		kΩ
R <sub>OUT</sub>	Output Impedance		5	7	12	Ω

**ABSOLUTE MAXIMUM RATINGS**

Supply Voltage, $V_{DD}$	4.6V
Inputs, $V_I$	-0.5V to $V_{DD} + 0.5V$
Outputs, $V_O$	-0.5V to $V_{DDO} + 0.5V$
Package Thermal Impedance, $\theta_{JA}$	112.7°C/W (0 lfpm)
Storage Temperature, $T_{STG}$	-65°C to 150°C

NOTE: Stresses beyond those listed under Absolute Maximum Ratings may cause permanent damage to the device. These ratings are stress specifications only. Functional operation of product at these conditions or any conditions beyond those listed in the *DC Characteristics* or *AC Characteristics* is not implied. Exposure to absolute maximum rating conditions for extended periods may affect product reliability.

**TABLE 3A. POWER SUPPLY DC CHARACTERISTICS,  $V_{DD} = V_{DDO} = 3.3V \pm 5\%$ ,  $T_A = 0^\circ C$  TO  $70^\circ C$** 

Symbol	Parameter	Test Conditions	Minimum	Typical	Maximum	Units
$V_{DD}$	Power Supply Voltage		3.135	3.3	3.465	V
$V_{DDO}$	Output Power Supply Voltage		3.135	3.3	3.465	V
$I_{DD}$	Power Supply Current				15	mA
$I_{DDO}$	Output Supply Current				8	mA

**TABLE 3B. POWER SUPPLY DC CHARACTERISTICS,  $V_{DD} = 3.3V \pm 5\%$ ,  $V_{DDO} = 2.5V \pm 5\%$ ,  $T_A = 0^\circ C$  TO  $70^\circ C$** 

Symbol	Parameter	Test Conditions	Minimum	Typical	Maximum	Units
$V_{DD}$	Positive Supply Voltage		3.135	3.3	3.465	V
$V_{DDO}$	Output Supply Voltage		2.375	2.5	2.625	V
$I_{DD}$	Power Supply Current				15	mA
$I_{DDO}$	Output Supply Current				8	mA

**TABLE 3C. LVCMOS / LVTTTL DC CHARACTERISTICS,  $V_{DD} = V_{DDO} = 3.3V \pm 5\%$ ,  $T_A = 0^\circ C$  TO  $70^\circ C$** 

Symbol	Parameter	Test Conditions	Minimum	Typical	Maximum	Units
$V_{IH}$	Input High Voltage		2		$V_{DD} + 0.3$	V
$V_{IL}$	Input Low Voltage		-0.3		1.3	V
$I_{IH}$	Input High Current	$V_{DD} = V_{IN} = 3.465V$			150	$\mu A$
$I_{IL}$	Input Low Current	$V_{DD} = 3.465V, V_{IN} = 0V$	-5			$\mu A$
$V_{OH}$	Output High Voltage	Refer to NOTE 1	2.6			V
		$I_{OH} = -16mA$	2.9			V
		$I_{OH} = -100\mu A$	3			V
$V_{OL}$	Output Low Voltage	Refer to NOTE 1			0.5	V
		$I_{OL} = 16mA$			0.25	V
		$I_{OL} = 100\mu A$			0.15	V

NOTE 1: Outputs terminated with  $50$  to  $V_{DDO}/2$ . See Parameter Measurement Section, "3.3V Output Load Test Circuit".

**TABLE 3D. LVCMOS / LVTTTL DC CHARACTERISTICS,  $V_{DD} = 3.3V \pm 5\%$ ,  $V_{DDO} = 2.5V \pm 5\%$ ,  $T_A = 0^\circ C$  TO  $70^\circ C$** 

Symbol	Parameter	Test Conditions	Minimum	Typical	Maximum	Units
$V_{IH}$	Input High Voltage		2		$V_{DD} + 0.3$	V
$V_{IL}$	Input Low Voltage		-0.3		1.3	V
$I_{IH}$	Input High Current	$V_{DD} = V_{IN} = 3.465V$			150	$\mu A$
$I_{IL}$	Input Low Current	$V_{DD} = 3.465V, V_{IN} = 0V$	-5			$\mu A$
$V_{OH}$	Output High Voltage; NOTE 1		2.1			V
$V_{OL}$	Output Low Voltage; NOTE 1				0.5	V

NOTE 1: Outputs terminated with 50 to  $V_{DDO}/2$ . See Parameter Measurement Section, "3.3V/2.5V Output Load Test Circuit".

**TABLE 4A. AC CHARACTERISTICS,  $V_{DD} = V_{DDO} = 3.3V \pm 5\%$ ,  $T_A = 0^\circ C$  TO  $70^\circ C$** 

Symbol	Parameter	Test Conditions	Minimum	Typical	Maximum	Units
$f_{MAX}$	Maximum Output Frequency				200	MHz
$t_{p_{LH}}$	Propagation Delay, Low-to-High; NOTE 1	$f \leq 166MHz$	2.0		3.3	ns
		$166MHz < f \leq 189.5MHz$	2.0		3.4	ns
tjit	Buffer Additive Phase Jitter, RMS; refer to Additive Phase Jitter Section	125MHz, Integration Range: 12kHz – 20MHz		0.173		ps
tsk(o)	Output Skew; NOTE 2, 4	$f = 133MHz$			45	ps
tsk(pp)	Part-to-Part Skew; NOTE 3, 4				500	ps
$t_R$	Output Rise Time	30% to 70%	250		500	ps
$t_F$	Output Fall Time	30% to 70%	250		500	ps
odc	Output Duty Cycle	$f \leq 189.5MHz$	40		60	%

All parameters measured at  $f_{MAX}$  unless noted otherwise.

NOTE 1: Measured from  $V_{DD}/2$  of the input to  $V_{DDO}/2$  of the output.

NOTE 2: Defined as skew between outputs at the same supply voltage and with equal load conditions.

Measured at  $V_{DDO}/2$ .

NOTE 3: Defined as skew between outputs on different devices operating at the same supply voltages and with equal load conditions. Using the same type of inputs on each device, the outputs are measured at  $V_{DDO}/2$ .

NOTE 4: This parameter is defined in accordance with JEDEC Standard 65.

**TABLE 4B. AC CHARACTERISTICS,  $V_{DD} = 3.3V \pm 5\%$ ,  $V_{DDO} = 2.5V \pm 5\%$ ,  $T_A = 0^\circ C$  TO  $70^\circ C$** 

Symbol	Parameter	Test Conditions	Minimum	Typical	Maximum	Units
$f_{MAX}$	Maximum Output Frequency				189.5	MHz
$t_{p_{LH}}$	Propagation Delay, Low-to-High; NOTE 1	$f \leq 166MHz$	2.3		3.7	ns
		$166MHz < f \leq 189.5MHz$	2.15		3.55	ns
tsk(o)	Output Skew; NOTE 2, 4	$f = 133MHz$			60	ps
tsk(pp)	Part-to-Part Skew; NOTE 3, 4				500	ps
$t_R$	Output Rise Time	30% to 70%	250		500	ps
$t_F$	Output Fall Time	30% to 70%	250		500	ps
odc	Output Duty Cycle	$f \leq 189.5MHz$	40		60	%

For NOTES, please see above Table 4A.

## ADDITIVE PHASE JITTER

The spectral purity in a band at a specific offset from the fundamental compared to the power of the fundamental is called the **dBc Phase Noise**. This value is normally expressed using a Phase noise plot and is most often the specified plot in many applications. Phase noise is defined as the ratio of the noise power present in a 1Hz band at a specified offset from the fundamental frequency to the power value of the fundamental. This ratio is expressed in decibels

(dBm) or a ratio of the power in the 1Hz band to the power in the fundamental. When the required offset is specified, the phase noise is called a **dBc** value, which simply means dBm at a specified offset from the fundamental. By investigating jitter in the frequency domain, we get a better understanding of its effects on the desired application over the entire time record of the signal. It is mathematically possible to calculate an expected bit error rate given a phase noise plot.

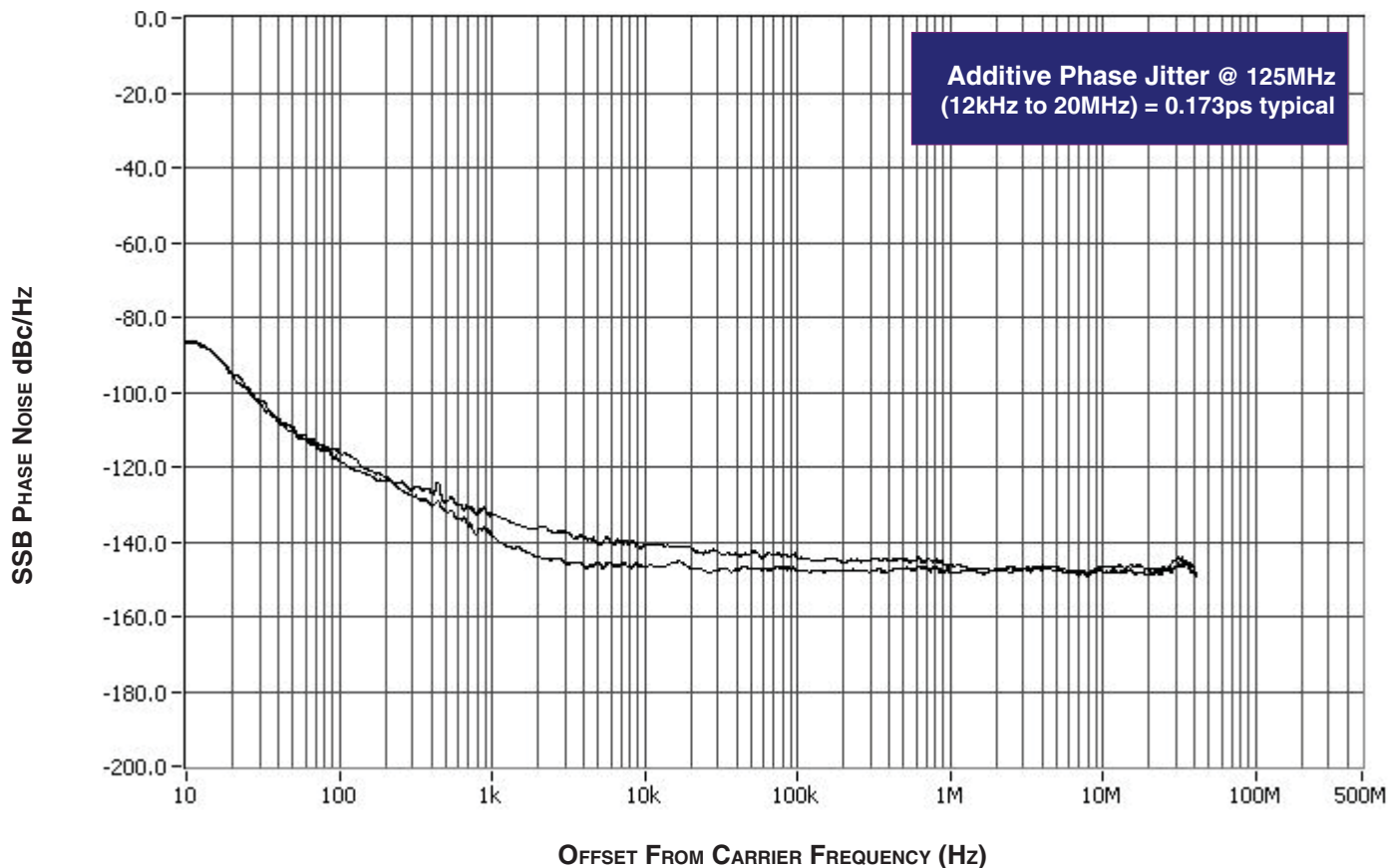

As with most timing specifications, phase noise measurements has issues. The primary issue relates to the limitations of the equipment. Often the noise floor of the equipment is higher than the noise floor

of the device. This is illustrated above. The device meets the noise floor of what is shown, but can actually be lower. The phase noise is dependant on the input source and measurement equipment.

# PARAMETER MEASUREMENT INFORMATION

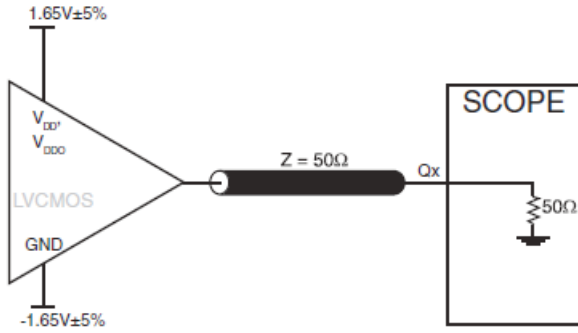

**3.3V OUTPUT LOAD AC TEST CIRCUIT**

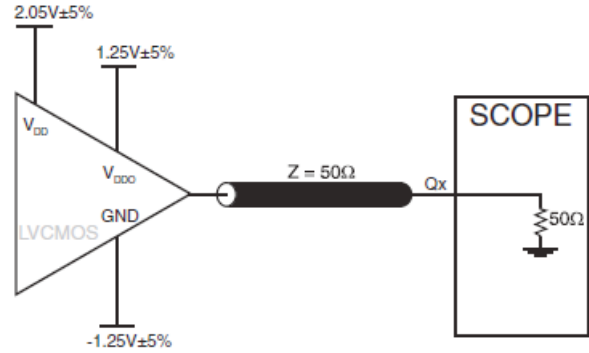

**2.5V OUTPUT LOAD AC TEST CIRCUIT**

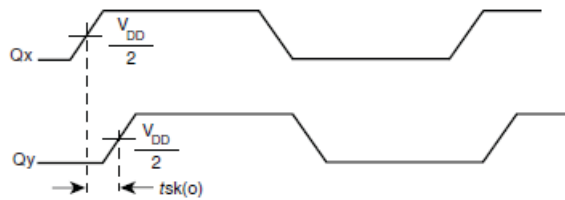

**OUTPUT SKEW**



**PART-TO-PART SKEW**

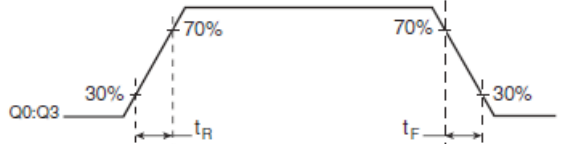

**OUTPUT RISE/FALL TIME**

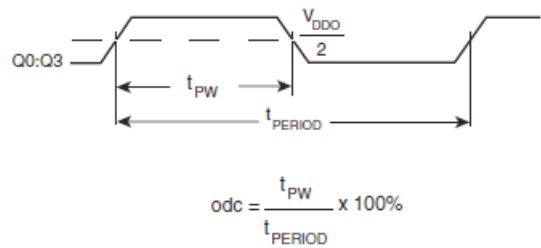

**OUTPUT DUTY CYCLE/PULSE WIDTH/PERIOD**

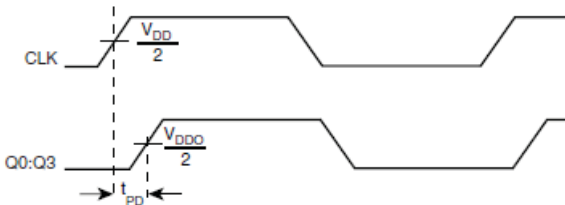

**PROPAGATION DELAY**

## APPLICATION INFORMATION

### RECOMMENDATIONS FOR UNUSED OUTPUT PINS

#### OUTPUTS:

##### LVC MOS OUTPUT:

All unused LVC MOS output can be left floating. There should be no trace attached.

## RELIABILITY INFORMATION

TABLE 5.  $\theta_{JA}$  vs. AIR FLOW TABLE

$\theta_{JA}$ by Velocity (Linear Feet per Minute)			
	0	200	500
Single-Layer PCB, JEDEC Standard Test Boards	153.3°C/W	128.5°C/W	115.5°C/W
Multi-Layer PCB, JEDEC Standard Test Boards	112.7°C/W	103.3°C/W	97.1°C/W

**NOTE:** Most modern PCB designs use multi-layered boards. The data in the second row pertains to most designs.

#### TRANSISTOR COUNT

The transistor count for 8304 is: 416

## PACKAGE OUTLINE - SUFFIX M FOR 8 LEAD SOIC

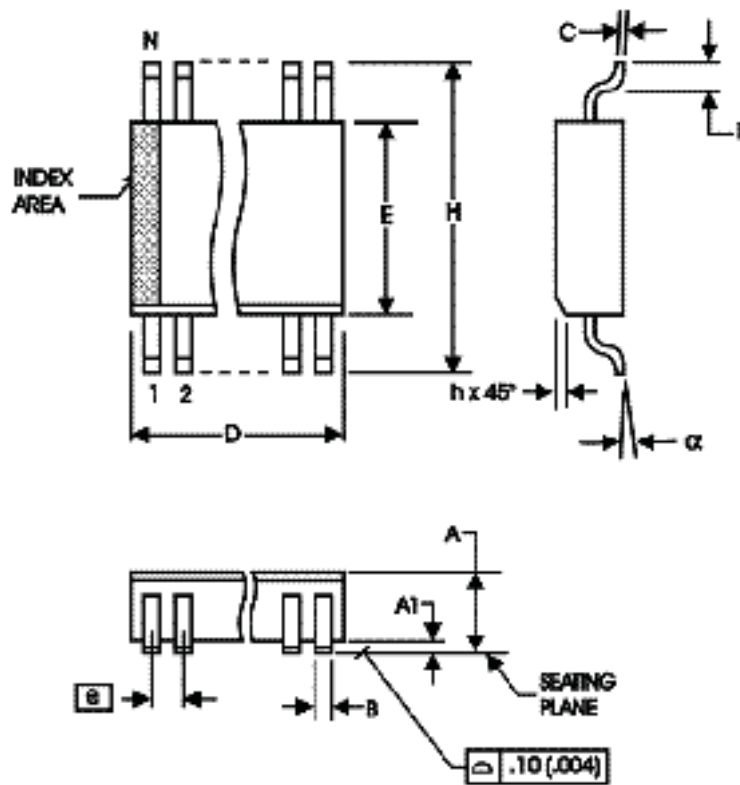

TABLE 6. PACKAGE DIMENSIONS - SUFFIX M

SYMBOL	Millimeters	
	MINIMUM	MAXIMUM
N	8	
A	1.35	1.75
A1	0.10	0.25
B	0.33	0.51
C	0.19	0.25
D	4.80	5.00
E	3.80	4.00
e	1.27 BASIC	
H	5.80	6.20
h	0.25	0.50
L	0.40	1.27
$\alpha$	0°	8°

Reference Document: JEDEC Publication 95, MS-012

**TABLE 7. ORDERING INFORMATION**

Part/Order Number	Marking	Package	Shipping Packaging	Temperature
8304AMLF	8304AMLF	8 lead "Lead Free" SOIC	Tube	0°C to +70°C
8304AMLFT	8304AMLF	8 lead "Lead Free" SOIC	Tape and Reel	0°C to +70°C
8304AMLN	8304AMLN	8 lead SOIC, Lead Free/Annealed	Tube	0°C to +70°C
8304AMLNT	8304AMLN	8 lead SOIC, Lead Free/Annealed	Tape and Reel	0°C to +70°C

REVISION HISTORY SHEET				
Rev	Table	Page	Description of Change	Date
B	T4A	3	<ul style="list-style-type: none"> <li>Revised <math>t_{p_{LH}}</math> (Propagation Delay) row from 2.3 Min. to 2 Min.</li> <li>Deleted <math>t_{p_{HL}}</math> row.</li> <li>Revised <math>tsk(o)</math> (Output Skew) row from 35 Max. to 80 Max.</li> <li>Revised <math>tsk(pp)</math> (Part-to-Part Skew) row from 200 Max. to 500 Max.</li> <li>General note changed from "...measured at 166MHz..." to "...measured at 150MHz..."</li> </ul>	12/4/01
	T4B	4	<ul style="list-style-type: none"> <li>Revised <math>t_{p_{LH}}</math> (Propagation Delay) row from 2.6 Min. to 2.3 Min.</li> <li>Deleted <math>t_{p_{HL}}</math> row.</li> <li>Revised <math>tsk(o)</math> (Output Skew) row from 35 Max. to 85 Max.</li> <li>Revised <math>tsk(pp)</math> (Part-to-Part Skew) row from 200 Max. to 500 Max.</li> <li>General note changed from "...measured at 166MHz..." to "...measured at 150MHz..."</li> </ul>	
C	T4A	3	<ul style="list-style-type: none"> <li>In AC table, revised <math>tsk(o)</math> row from 80ps Max. to 45ps Max.</li> <li>Added <math>f = 133\text{MHz}</math> in Test Conditions column.</li> <li>In odc row, deleted test conditions.</li> </ul>	12/11/01
	T4B	4	<ul style="list-style-type: none"> <li>In notes, changed 150MHz to <math>f_{MAX}</math>.</li> <li>In AC table, revised <math>tsk(o)</math> row from 80ps Max. to 60ps Max.</li> <li>Added <math>f = 133\text{MHz}</math> in Test Conditions column.</li> <li>In odc row, deleted test conditions</li> <li>In notes, changed 150MHz to <math>f_{MAX}</math>.</li> </ul>	
C	T7	10	In the Ordering Information table, Marking column, revised marking to read 8304AM from 8304AM.	3/11/02
D	T3B	3	LVC MOS/LVTTL DC Characteristics Table, added $I_{OH}$ and $I_{OL}$ Test Conditions to $V_{OH}$ and $V_{OL}$ rows.	4/4/02
E	T1	1	Pin Assignment - adjusted dimensions.	4/13/04
	T2	2	Pin Descriptions - changed $V_{DD}$ description to Core supply pin.	
	T3A & T3C	2	Pin Characteristics - changed $C_{IN}$ max 4pF to typical 4pF.	
E	T7	3 & 4	Deleted $R_{PULLUP}$ row.	4/13/04
		8	<ul style="list-style-type: none"> <li>Added 5W min. and 12W max. to <math>R_{OUT}</math>.</li> <li>Power Supply tables - changed <math>V_{DD}</math> parameter from Power to Core.</li> <li>Ordering Information table - added "Lead Free/Annealed" marking.</li> <li>Updated format throughout the data sheet.</li> </ul>	
F	T4A	1	Features section, changed Maximum output frequency bullet from 166MHz to 200MHz.	6/1/04
		4	<ul style="list-style-type: none"> <li>3.3V AC Table - changed 166MHz max. to 200MHz max.</li> <li>Added another line for Propagation Delay.</li> <li>Changed test conditions in Output Duty Cycle from 166MHz to 189.5MHz.</li> </ul>	
	T4B	4	<ul style="list-style-type: none"> <li>3.3V AC Table - changed 166MHz max. to 189.5MHz max.</li> <li>Added another line for Propagation Delay.</li> <li>Changed test conditions in Output Duty Cycle from 166MHz to 189.5MHz</li> </ul>	
F	T7	8	Ordering Information table - added "Lead Free" marking.	9/13/04
G	T4A	1	Features Section - added Additive Phase Jitter bullet.	6/11/07
		4	3.3V AC Characteristics Table - added Additive Phase Jitter row.	
		5	Added Additive Phase Jitter plot.	
G	T4A	7	Added Recommendations for Unused Output Pins.	
H		1	Pin Assignment - corrected "pullup" label to "pulldown" label.	10/29/10
H	T7	9	Ordering Information - removed leaded devices. Updated data sheet format.	11/19/15

**Corporate Headquarters**

6024 Silver Creek Valley Road  
San Jose, California 95138

**Sales**

800-345-7015 or +408-284-8200  
Fax: 408-284-2775  
www.IDT.com

**Technical Support**

**email:** [clocks@idt.com](mailto:clocks@idt.com)

DISCLAIMER Integrated Device Technology, Inc. (IDT) and its subsidiaries reserve the right to modify the products and/or specifications described herein at any time and at IDT's sole discretion. All information in this document, including descriptions of product features and performance, is subject to change without notice. Performance specifications and the operating parameters of the described products are determined in the independent state and are not guaranteed to perform the same way when installed in customer products. The information contained herein is provided without representation or warranty of any kind, whether express or implied, including, but not limited to, the suitability of IDT's products for any particular purpose, an implied warranty of merchantability, or non-infringement of the intellectual property rights of others. This document is presented only as a guide and does not convey any license under intellectual property rights of IDT or any third parties.

IDT's products are not intended for use in applications involving extreme environmental conditions or in life support systems or similar devices where the failure or malfunction of an IDT product can be reasonably expected to significantly affect the health or safety of users. Anyone using an IDT product in such a manner does so at their own risk, absent an express, written agreement by IDT.

Integrated Device Technology, IDT and the IDT logo are registered trademarks of IDT. Other trademarks and service marks used herein, including protected names, logos and designs, are the property of IDT or their respective third party owners.

Copyright 2015. All rights reserved.