



DUAL, ISOLATED, BIDIRECTIONAL DIGITAL COUPLER

FEATURES

- Replaces High-Performance Optocouplers
- Data Rate: 80 M Baud, Typ
- Low Power Consumption: 25 mW Per Channel, Max
- Two Channels, Each Bidirectional, Programmable by User
- Partial Discharge Tested: 2400 Vrms
- Creepage Distance of 7,2 mm
- Low Cost Per Channel
- Available in SO Package
- UL 1577 Certified

APPLICATIONS

- Digital Isolation for A/D, D/A Conversion
- Isolated RS-485 Interface
- Multiplexed Data Transmission
- Isolated Parallel to Serial Interface
- Test Equipment
- Microprocessor System Interface
- Isolated Line Receiver
- Ground Loop Elimination

DESCRIPTION

The ISO150 is a 2-channel, galvanically-isolated data coupler capable of data rates of 80M Baud, typical. Each channel can be individually programmed to transmit data in either direction.

Data is transmitted across the isolation barrier by coupling complementary pulses through high voltage 0.4 pF capacitors. Receiver circuitry restores the pulses to standard logic levels. Differential signal transmission rejects isolation-mode voltage transients up to 1.6 kV/μs

The ISO150 avoids problems commonly associated with optocouplers. Optically isolated couplers require high current pulses and allowance must be made for LED aging. The ISO150's Bi-CMOS circuitry operates at 25 mW per channel.

The ISO150 is available in an SO-28 and is specified for operation from -40°C to 85°C.

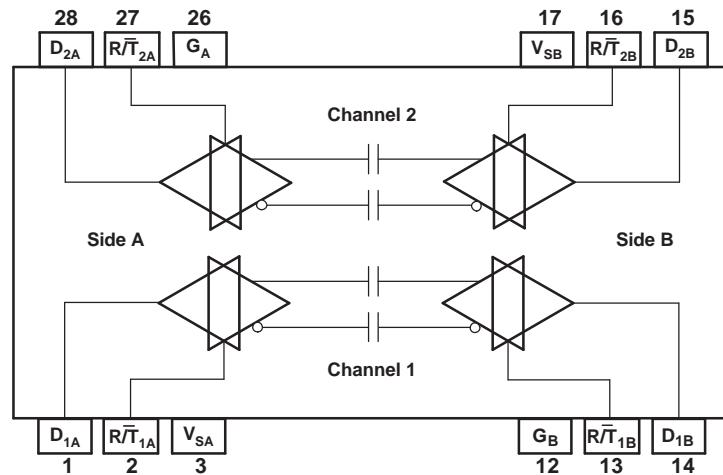

Please be aware that an important notice concerning availability, standard warranty, and use in critical applications of Texas Instruments semiconductor products and disclaimers thereto appears at the end of this data sheet.



This integrated circuit can be damaged by ESD. Texas Instruments recommends that all integrated circuits be handled with appropriate precautions. Failure to observe proper handling and installation procedures can cause damage.

ESD damage can range from subtle performance degradation to complete device failure. Precision integrated circuits may be more susceptible to damage because very small parametric changes could cause the device not to meet its published specifications.

ORDERING INFORMATION⁽¹⁾

PRODUCT	PACKAGE LEAD	PACKAGE DESIGNATOR	SPECIFIED TEMPERATURE RANGE	PACKAGE MARKING	ORDERING NUMBER	TRANSPORT MEDIA, QUANTITY
ISO150AU	SO-28	DVB	–40°C to 85°C	ISO150AU	ISO150AU	Rails, 28
					ISO150AU/1K	Tape and Reel, 1000

- (1) For the most current package and ordering information, see the Package Option Addendum at the end of this document, or see the TI website at www.ti.com.

ABSOLUTE MAXIMUM RATINGS

over operating free-air temperature range (unless otherwise noted)^{(1) (2)}

	UNIT
Storage temperature	–40°C to 125°C
V _S Supply voltage	–0.5 V to 6 V
V _I Transmitter input voltage	–0.5 V to V _S + 0.5 V
V _O Receiver output voltage	–0.5 V to V _S + 0.5 V
R/ \bar{T}_x inputs	–0.5 V to V _S + 0.5 V
V _{ISO} Isolation voltage dV/dt	500 kV/μs
D _x Short to ground	Continuous
T _J Junction temperature	125°C
Lead temperature (soldering, 10s)	260°C

- (1) Stresses beyond those listed under *Absolute Maximum Ratings* may cause permanent damage to the device. These are stress ratings only and functional operation of the device at these or any other conditions beyond those indicated under *Recommended Operating Conditions* is not implied. Exposure to absolute maximum rated conditions for extended periods may affect device reliability.
- (2) This isolator is suitable for basic insulation applications within the safety limiting data. Maintenance of the safety data must be ensured by means of protective circuitry.

REGULATORY INFORMATION

UL
Recognized under 1577 Component Recognition Program ⁽¹⁾
File Number: E181974

- (1) Production tested at 2400 VRMS for 1 second in accordance with UL 1577.

ELECTRICAL CHARACTERISTICS

 At $T_A = 25^\circ\text{C}$ and $V_S = 5\text{ V}$ (unless otherwise noted)

PARAMETER		TEST CONDITIONS	ISO150AU			UNIT	
			MIN	TYP	MAX		
ISOLATION PARAMETERS							
Rated Voltage, Continuous		60 Hz	1500			Vrms	
Partial Discharge, 100% Test ⁽¹⁾		1s, 5pC	2400			Vrms	
Creepage distance (external)	SO-U Package		7.2			mm	
Internal isolation distance			0.10			mm	
Isolation voltage transient immunity ⁽²⁾			1.6			kV/μs	
Barrier impedance			$>10^{14} \parallel 7$			$\Omega \parallel \text{pF}$	
Leakage current		240 Vrms, 50 Hz	0.6			μArms	
DC PARAMETERS							
Logic output voltage	HIGH, V_{OH}	$I_{OH} = 6\text{ mA}$	$V_S - 1$	V_S		V	
	LOW, V_{OL}	$I_{OL} = 6\text{ mA}$	0	0.4			
Logic output short-circuit current		Source or sink	30			mA	
Logic input voltage	HIGH ⁽³⁾		2	V_S		V	
	LOW ⁽³⁾		0	0.8			
Logic input capacitance			5			pF	
Logic input current			<1			nA	
Power-supply voltage range ⁽³⁾			3	5	5.5	V	
Power-supply current ⁽⁴⁾	Transmit mode	DC	0.001			100	μA
		50M Baud	14				mA
	Receive mode	DC	7.2			10	mA
		50M Baud	16				
AC PARAMETERS							
Data rate	Maximum ⁽⁵⁾	$C_L = 50\text{ pF}$	50	80		M Baud	
	Minimum		DC				
Propagation time ⁽⁶⁾		$C_L = 50\text{ pF}$	27			40	ns
Propagation delay skew ⁽⁷⁾		$C_L = 50\text{ pF}$	0.5			2	ns
Pulse width distortion ⁽⁸⁾		$C_L = 50\text{ pF}$	1.5			6	ns
Output rise-and-fall time, 10% to 90%		$C_L = 50\text{ pF}$	9			14	ns
Mode switch time	Receive to Transmit		13				ns
	Transmit to receive ⁽⁹⁾		75				ns
TEMPERATURE RANGE							
Operating range			-40			85	°C
Storage			-40			125	°C
Thermal resistance, θ_{JA}			75				°C/W

(1) All devices receive a 1s test. Failure criterion is ≥ 5 PULSES OF ≥ 5 Pc.

(2) The voltage rate-of-change across the isolation barrier that can be sustained without data errors.

(3) Logic inputs are HCT-type and thresholds are a function of power-supply voltage with approximately 0.4 V hysteresis – see text.

(4) Supply current measured with both transceivers set for the indicated mode. Supply current varies with data rate – see typical characteristics.

(5) Calculated from the maximum pulse width distortion (PWD), where Data Rate = $0.3/\text{PWD}$.

(6) Propagation time measured from $V_{IN} = 1.5\text{ V}$ to $V_O = 2.5\text{ V}$.

(7) The difference in propagation time of channel A and channel B in any combination of transmission directions.

(8) The difference between propagation time of a rising edge and a falling edge.

(9) When the device is powered up or direction is changed, the transceiver output is indeterminate (either high or low) and cannot be known until an input signal is applied. The output begins to track the input as soon as the input receives a change in logic state, either low to high or high to low.

PIN CONFIGURATION

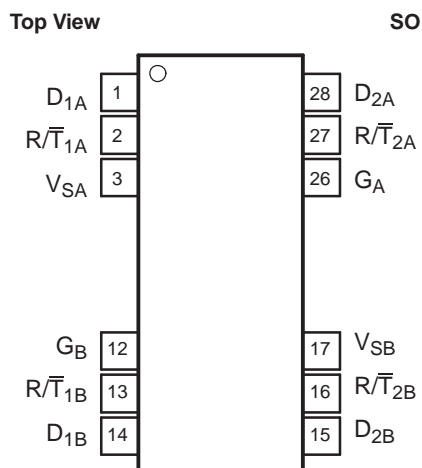

TERMINAL FUNCTIONS

TERMINAL		DESCRIPTION
NAME	NO.	
D _{1A}	1	Data in or data out for transceiver 1A, $\overline{R/T}_{1A}$ held low makes D _{1A} an input pin.
$\overline{R/T}_{1A}$	2	Receive/transmit switch controlling transceiver 1A.
V _{SA}	3	+5V supply pin for side A, which powers transceivers 1A and 2A.
G _B	12	Ground pin for transceivers 1B and 2B.
$\overline{R/T}_{1B}$	13	Receive/transmit switch controlling transceiver 1B.
D _{1B}	14	Data in or data out for transceiver 1B. $\overline{R/T}_{1B}$ held LOW makes D _{1B} an input pin.
D _{2B}	15	Data in or data out for transceiver 2B. $\overline{R/T}_{2B}$ held LOW makes D _{2B} an input pin.
$\overline{R/T}_{2B}$	16	Receive/transmit switch controlling D _{2B} .
V _{SB}	17	+5V supply pin for side B, which powers transceivers 1B and 2B.
G _A	26	Ground pin for transceivers 1A and 2A.
$\overline{R/T}_{2A}$	27	Receive/transmit switch controlling transceiver 2A.
D _{2A}	28	Data in or data out for transceiver 2A, $\overline{R/T}_{21A}$ held low makes D _{2A} an input pin.

TYPICAL CHARACTERISTICS

At $T_A = 25^\circ\text{C}$ and $V_S = 5\text{ V}$, unless otherwise noted.

SUPPLY CURRENT PER CHANNEL vs SUPPLY VOLTAGE

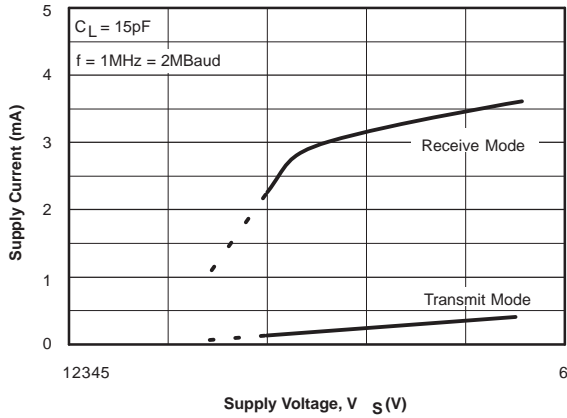

Figure 1.

POWER CONSUMPTION PER CHANNEL vs FREQUENCY

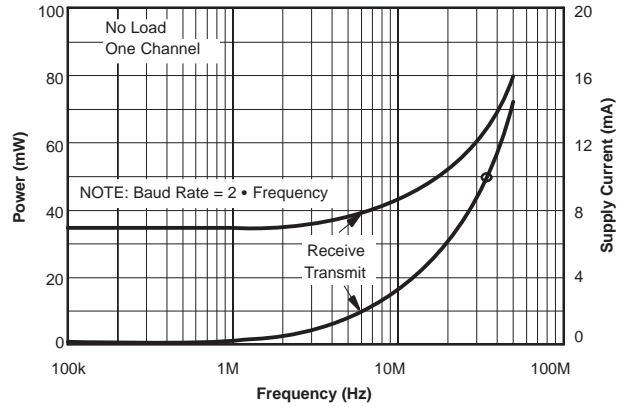

Figure 2.

SUPPLY CURRENT PER CHANNEL vs TEMPERATURE

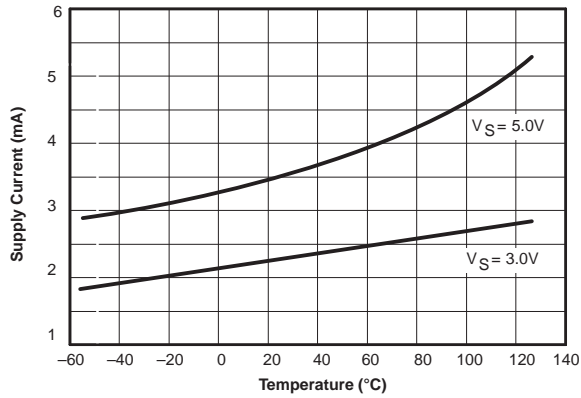

Figure 3.

TYPICAL RISE AND FALL TIMES vs CAPACITIVE LOAD vs SUPPLY VOLTAGE

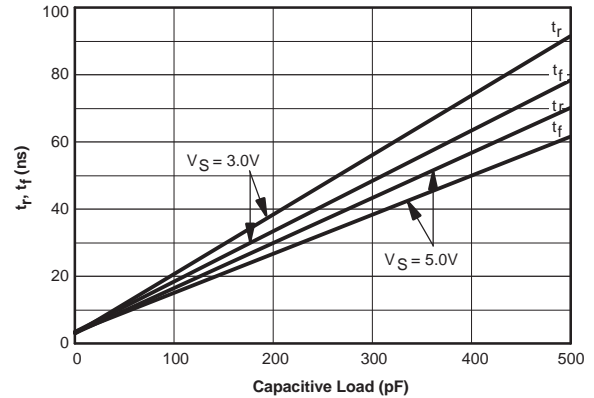

Figure 4.

NORMALIZED RISE-AND-FALL TIME vs TEMPERATURE

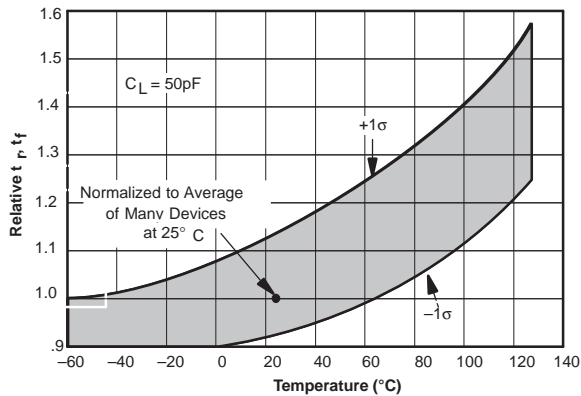

Figure 5.

PROPAGATION DELAY vs SUPPLY VOLTAGE

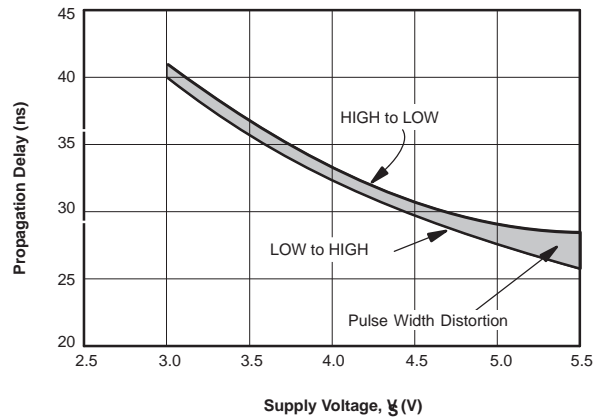

Figure 6.

TYPICAL CHARACTERISTICS (continued)

At $T_A = 25^\circ\text{C}$ and $V_S = 5\text{ V}$, unless otherwise noted.

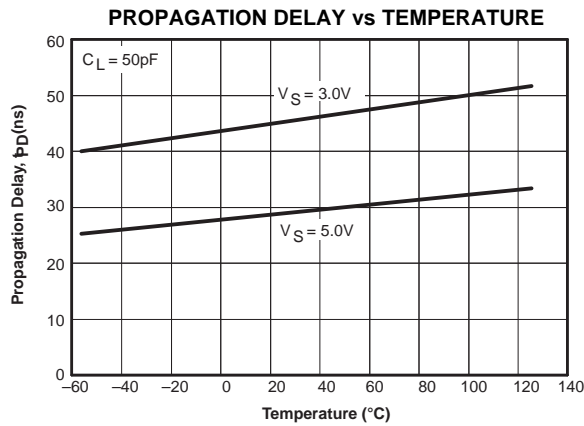

Figure 7.

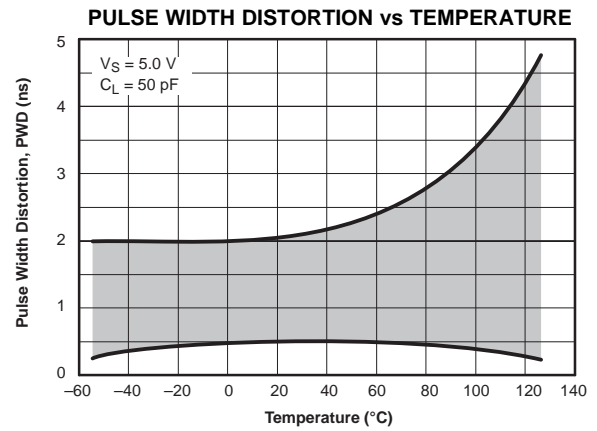

Figure 8.

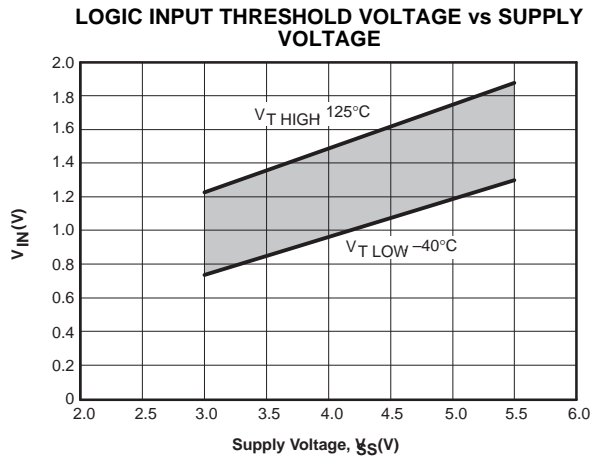

Figure 9.

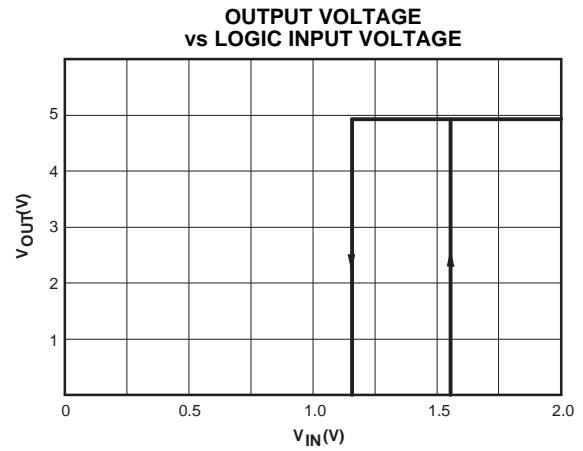

Figure 10.

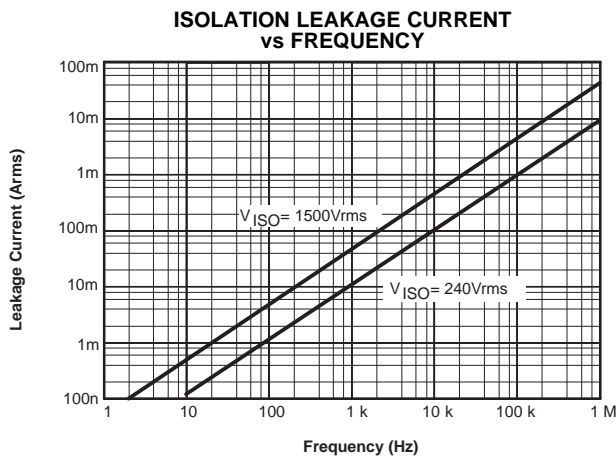

Figure 11.

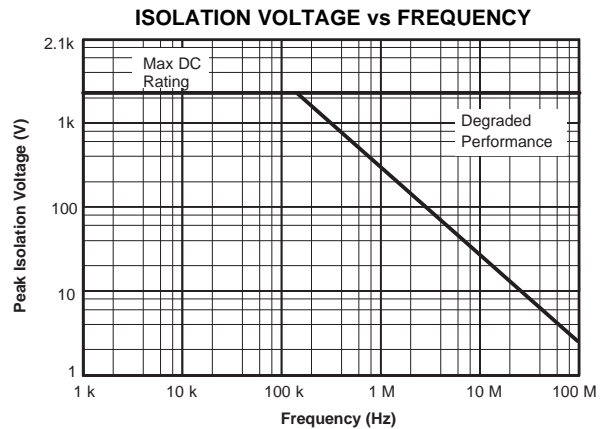

Figure 12.

TYPICAL CHARACTERISTICS (continued)

At $T_A = 25^\circ\text{C}$ and $V_S = 5\text{ V}$, unless otherwise noted.

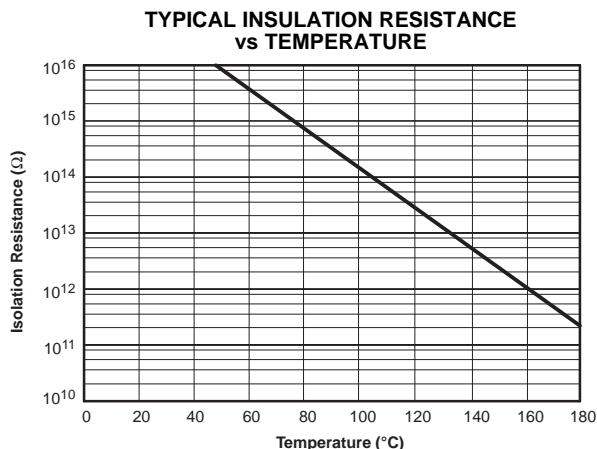

Figure 13.

ISOLATION BARRIER

Data is transmitted by coupling complementary logic pulses to the receiver through two 0.4 pF capacitors. These capacitors are built into the ISO150 package with Faraday shielding to guard against false triggering by external electrostatic fields.

The integrity of the isolation barrier of the ISO150 is verified by partial discharge testing: 2400 Vrms, 60 Hz, is applied across the barrier for one second while measuring any tiny discharge currents that might flow through the barrier. These current pulses are

produced by localized ionization within the barrier; this is the most sensitive and reliable indicator of barrier integrity and longevity, and does not damage the barrier. A device fails the test if five or more current pulses of 5pC or greater are detected.

Conventional isolation barrier testing applies test voltage far in excess of the rated voltage to catastrophically break down a marginal device. A device that passes the test may be weakened, and lead to premature failure.

APPLICATION INFORMATION

Figure 14 shows the ISO150 connected for basic operation; Channel 1 is configured to transmit data from side B to A, whereas Channel 2 is set for transmission from side A to B. The R/T pins for each of the four transceivers are shown connected to the required logic level for the transmission direction

shown. The transmission direction can be controlled by logic signals applied to the R/T pins. Channel 1 and 2 can be independently controlled for the desired transmission direction. See Figure 15 and Figure 16 for application examples using the ISO150.

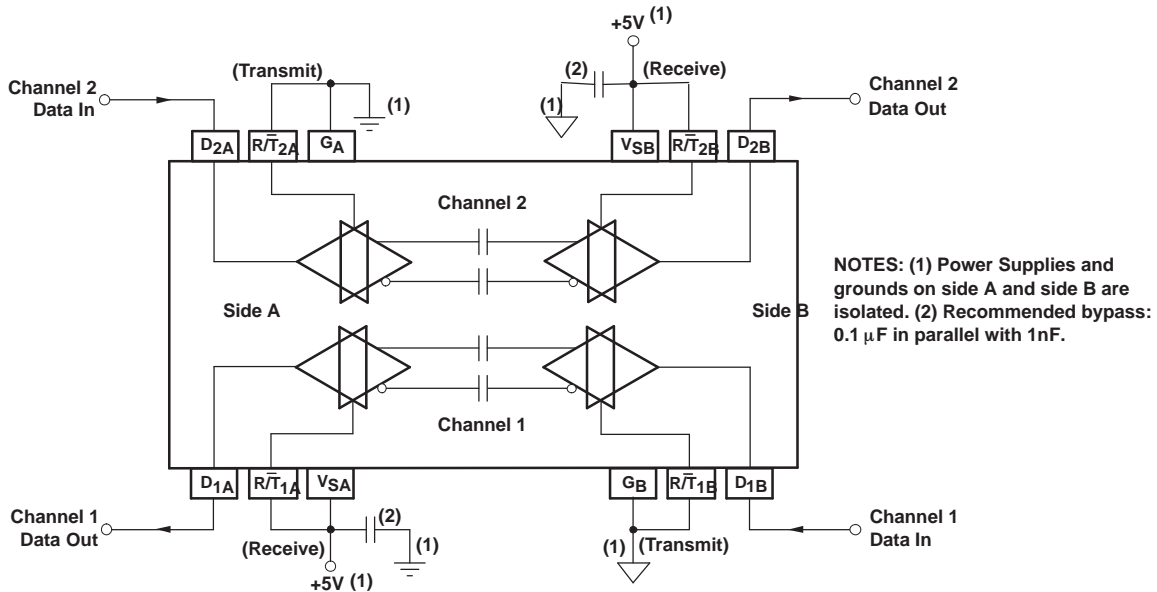

Figure 14. Basic Operation Diagram

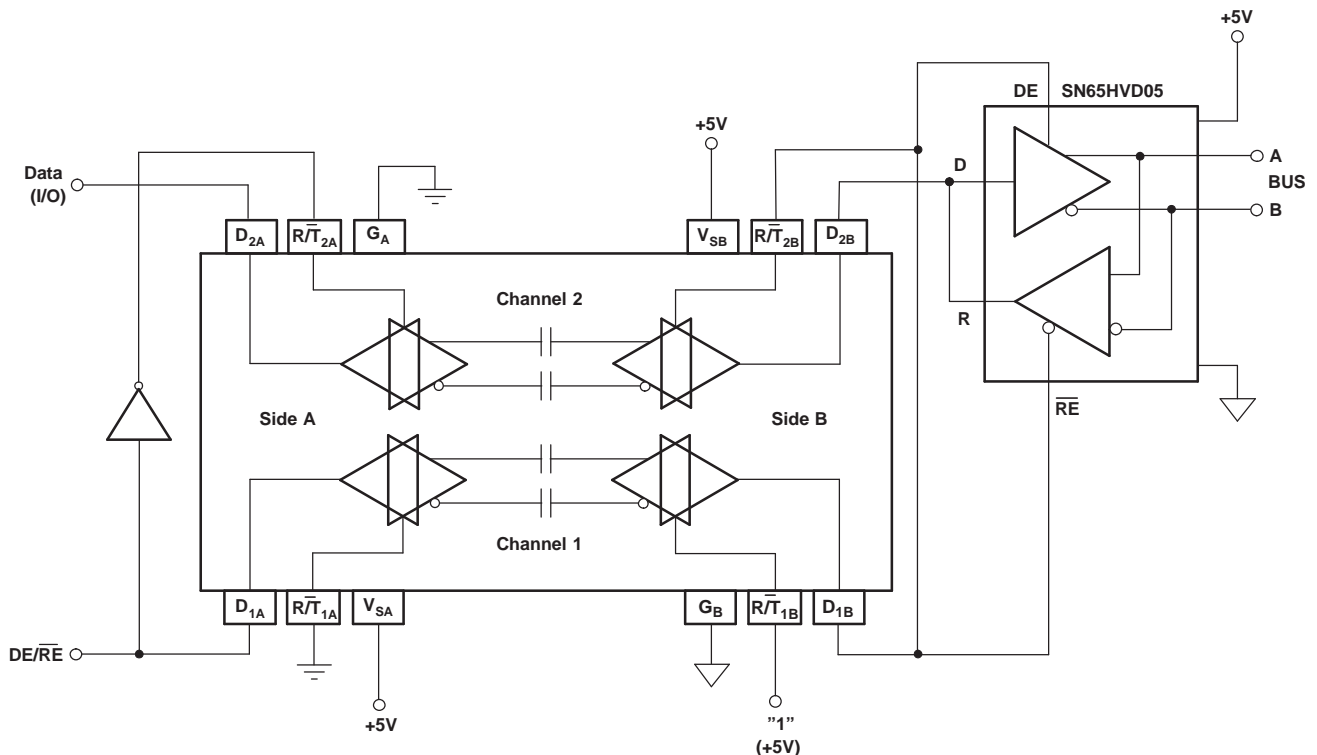

Figure 15. Isolated RS-485 Interface

LOGIC LEVELS

A single pin serves as a data input or output, depending on the mode selected. Logic inputs are CMOS with thresholds set for TTL compatibility. The logic threshold is approximately 1.3 V with 5 V supplies with approximately 400 mV of hysteresis. Input logic thresholds vary with the power-supply voltage. Drive the logic inputs with signals that swing the full logic voltage swing, note that the ISO150 will use somewhat greater quiescent current if logic inputs do not swing within 0.5 V of the power-supply rails.

In receive mode, the data output can drive 15 standard LS-TTL loads. It will also drive CMOS loads. The output drive circuits are CMOS.

POWER SUPPLY

Separate, isolated power supplies must be connected to side A and side B to provide galvanic isolation. Nominal rated supply voltage is 5 V. Operation extends from 3 V to 5.5 V. Power supplies should be bypassed close to the device pins on both sides of the isolation barrier.

The V_S pin for each side powers the transceivers for both channel 1 and 2. The specified supply current is the total of both transceivers on one side, both operating in the indicated mode. Supply current for one transceiver in transmit mode and one in receive mode can be estimated by averaging the specifications for transmit and receive operation. Supply current varies with the data transmission rate — see the typical characteristics.

POWER-UP STATE

When the device is powered up or direction is changed, the transceiver output is indeterminate (either high or low) and cannot be known until an input signal is applied. The output begins to track the input as soon as the input receives a change in logic state, either low to high or high to low.

SIGNAL LOSS

The ISO150's differential-mode signal transmission and careful receiver design make it highly immune to voltage across the isolation barrier (isolation-mode voltage). Rapidly changing isolation-mode voltage can cause data errors. As the rate of change of isolation voltage is increased, there is a very sudden increase in data errors. Approximately 50% of all ISO150s will begin to produce data errors with isolation-mode transients of 1.6kV/ μ s. This may occur as low as 500 V/ μ s in some devices. In comparison, a 1000 Vrms, 60 Hz isolation-mode voltage has a rate of change of approximately 0.5V/ μ s.

Still, some applications with large, noisy isolation-mode voltage can produce data errors by causing the receiver output to change states. After a data error, subsequent changes in input data will produce correct output data.

PROPAGATION DELAY AND SKEW

Logic transitions are delayed approximately 27ns through the ISO150. Some applications are sensitive to data skew—the difference in propagation delay between channel 1 and channel 2. Skew is less than 2ns between channel 1 and channel 2. Applications using more than one ISO150 must allow for somewhat greater skew from device to device. As all devices are tested for delay times of 20ns min to 40ns max, 20ns is the largest device-to-device data skew.

MODE CHANGES

The transmission direction of a channel can be changed *on the fly* by reversing the logic levels at the channel's R/\bar{T} pin. Note that when channel direction is changed, the output state of the channel is indeterminate (either high or low) and cannot be known until an input signal is applied. The output begins to track the input as soon as the input receives a change in logic state, either low to high or high to low.

STANDBY MODE

Quiescent current of each transceiver circuit is very low in transmit mode when input data is not changing (1nA typical). To conserve power when data transmission is not required, program both side A and B transceivers for transmit mode. Input data applied to either transceiver is ignored by the other side. High-speed data applied to either transceiver will increase quiescent current.

CIRCUIT LAYOUT

The high speed of the ISO150 and its isolation barrier require careful circuit layout. Use good high speed logic layout techniques for the input and output data lines. Power supplies should be bypassed close to the device pins on both sides of the isolation barrier. Use low inductance connections. Ground planes are recommended.

Maintain spacing between side 1 and side 2 circuitry equal or greater than the spacing between the missing pins of the ISO150 (approximately 7mm).

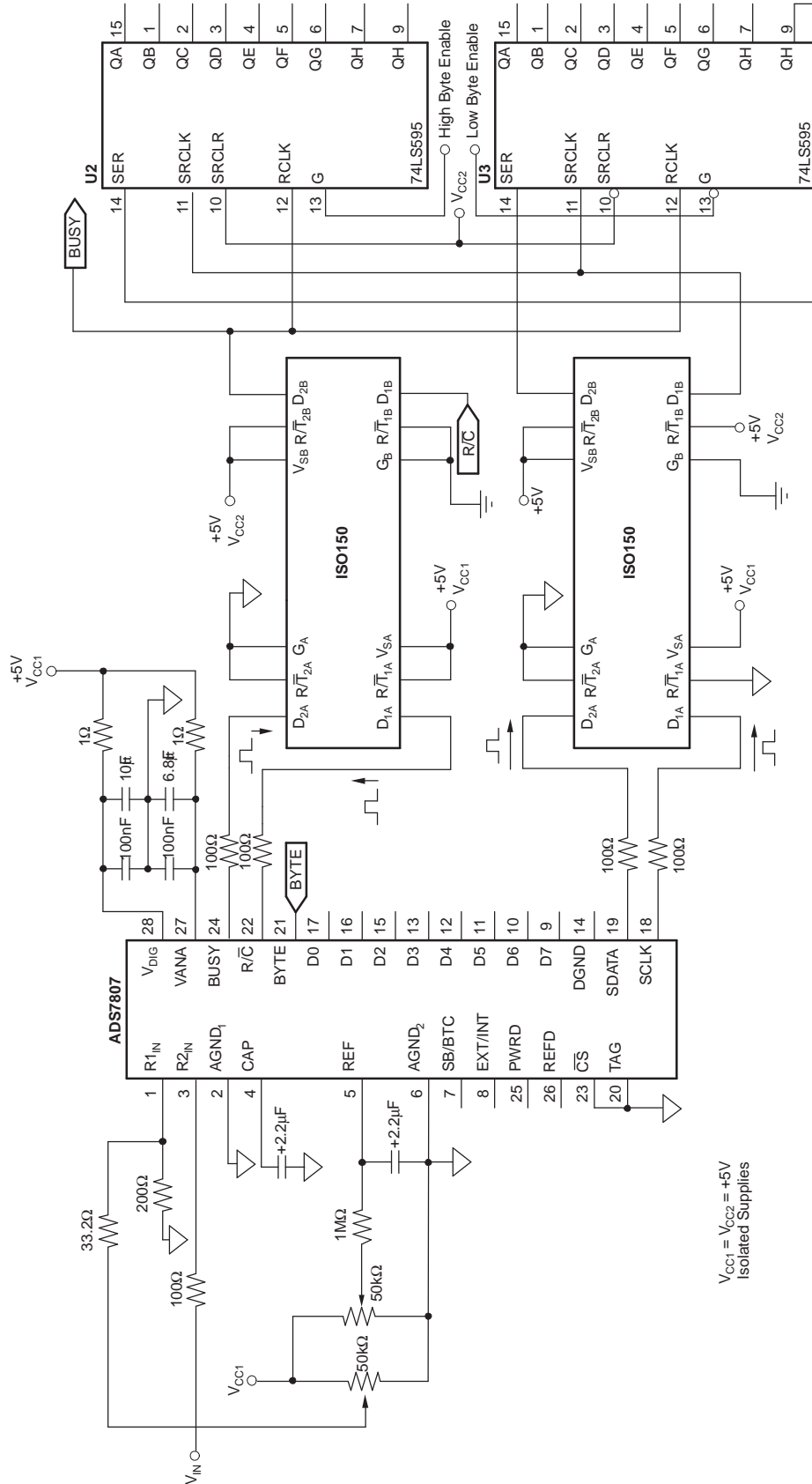



$V_{CC1} = V_{CC2} = +5V$
Isolated Supplies

Figure 16. The ISO150 and the ADS7807 are Used to Reduce Circuit Noise in a Mixed-Signal Application

Revision History

Changes from Original (August 1994) to Revision A	Page
• Changed Features Bullet - From: Plastic DIP and SOIC Packages To: Available in SO Package.....	1
• Changed From: ISO150 is available in a 24-pin DIP package To: The ISO150 is available in an SO-28.....	1
• Changed From Burr-Brown To: Burr-Brown Products from Texas Instruments (New layout).....	1
• Deleted the DIP Package from the Ordering Information Table.....	2
• Deleted DIP-P Package from Creepage distance (external) in the Electrical Characteristics Table.....	3
• Deleted DIP-P Package illustration from the Pin Configuration.....	4
• Changed Pin Configuration From: SOIC Package To: SO Package.....	4
• Changed Circuit Layout paragraph From: ISO150 (approximately 16mm for the DIP version). Sockets are not recommended. To: ISO150 (approximately 7mm).....	9
Changes from Revision A (February 2003) to Revision B	Page
• Changed Format and layout.....	1
• Added Note 9 to the Electrical Characteristics Table.....	3
Changes from Revision B (February 2005) to Revision C	Page
• Added Feature: UL 1577 Certified.....	1
• Added Table: Regulatory Information.....	2
Changes from Revision C (October 2007) to Revision D	Page
• Changed Abs Max Table - Junction Temperature From: 175°C to 125°C.....	2

PACKAGING INFORMATION

Orderable Device	Status (1)	Package Type	Package Drawing	Pins	Package Qty	Eco Plan (2)	Lead/Ball Finish (6)	MSL Peak Temp (3)	Op Temp (°C)	Device Marking (4/5)	Samples
ISO150AP	OBSOLETE	PDIP	NVG	12		TBD	Call TI	Call TI			
ISO150AU	ACTIVE	SOP	DVB	12	20	Green (RoHS & no Sb/Br)	CU NIPDAU	Level-3-260C-168 HR	-40 to 85	ISO150AU	
ISO150AU-1	OBSOLETE	SOIC	DVA	8		TBD	Call TI	Call TI			
ISO150AU/1K	ACTIVE	SOP	DVB	12	1000	Green (RoHS & no Sb/Br)	CU NIPDAU	Level-3-260C-168 HR		ISO150AU	
ISO150AUG4	ACTIVE	SOP	DVB	12	20	Green (RoHS & no Sb/Br)	CU NIPDAU	Level-3-260C-168 HR	-40 to 85	ISO150AU	

(1) The marketing status values are defined as follows:

ACTIVE: Product device recommended for new designs.

LIFEBUY: TI has announced that the device will be discontinued, and a lifetime-buy period is in effect.

NRND: Not recommended for new designs. Device is in production to support existing customers, but TI does not recommend using this part in a new design.

PREVIEW: Device has been announced but is not in production. Samples may or may not be available.

OBSOLETE: TI has discontinued the production of the device.

(2) Eco Plan - The planned eco-friendly classification: Pb-Free (RoHS), Pb-Free (RoHS Exempt), or Green (RoHS & no Sb/Br) - please check <http://www.ti.com/productcontent> for the latest availability information and additional product content details.

TBD: The Pb-Free/Green conversion plan has not been defined.

Pb-Free (RoHS): TI's terms "Lead-Free" or "Pb-Free" mean semiconductor products that are compatible with the current RoHS requirements for all 6 substances, including the requirement that lead not exceed 0.1% by weight in homogeneous materials. Where designed to be soldered at high temperatures, TI Pb-Free products are suitable for use in specified lead-free processes.

Pb-Free (RoHS Exempt): This component has a RoHS exemption for either 1) lead-based flip-chip solder bumps used between the die and package, or 2) lead-based die adhesive used between the die and leadframe. The component is otherwise considered Pb-Free (RoHS compatible) as defined above.

Green (RoHS & no Sb/Br): TI defines "Green" to mean Pb-Free (RoHS compatible), and free of Bromine (Br) and Antimony (Sb) based flame retardants (Br or Sb do not exceed 0.1% by weight in homogeneous material)

(3) MSL, Peak Temp. - The Moisture Sensitivity Level rating according to the JEDEC industry standard classifications, and peak solder temperature.

(4) There may be additional marking, which relates to the logo, the lot trace code information, or the environmental category on the device.

(5) Multiple Device Markings will be inside parentheses. Only one Device Marking contained in parentheses and separated by a "~" will appear on a device. If a line is indented then it is a continuation of the previous line and the two combined represent the entire Device Marking for that device.

(6) Lead/Ball Finish - Orderable Devices may have multiple material finish options. Finish options are separated by a vertical ruled line. Lead/Ball Finish values may wrap to two lines if the finish value exceeds the maximum column width.

Important Information and Disclaimer: The information provided on this page represents TI's knowledge and belief as of the date that it is provided. TI bases its knowledge and belief on information provided by third parties, and makes no representation or warranty as to the accuracy of such information. Efforts are underway to better integrate information from third parties. TI has taken and continues to take reasonable steps to provide representative and accurate information but may not have conducted destructive testing or chemical analysis on incoming materials and chemicals. TI and TI suppliers consider certain information to be proprietary, and thus CAS numbers and other limited information may not be available for release.

In no event shall TI's liability arising out of such information exceed the total purchase price of the TI part(s) at issue in this document sold by TI to Customer on an annual basis.

TAPE AND REEL INFORMATION



QUADRANT ASSIGNMENTS FOR PIN 1 ORIENTATION IN TAPE



*All dimensions are nominal

Device	Package Type	Package Drawing	Pins	SPQ	Reel Diameter (mm)	Reel Width W1 (mm)	A0 (mm)	B0 (mm)	K0 (mm)	P1 (mm)	W (mm)	Pin1 Quadrant
ISO150AU/1K	SOP	DVB	12	1000	330.0	24.4	10.9	18.3	3.2	12.0	24.0	Q1

TAPE AND REEL BOX DIMENSIONS



*All dimensions are nominal

Device	Package Type	Package Drawing	Pins	SPQ	Length (mm)	Width (mm)	Height (mm)
ISO150AU/1K	SOP	DVB	12	1000	367.0	367.0	45.0

NVG (R-PDIP-T12/24)

PLASTIC DUAL-IN-LINE

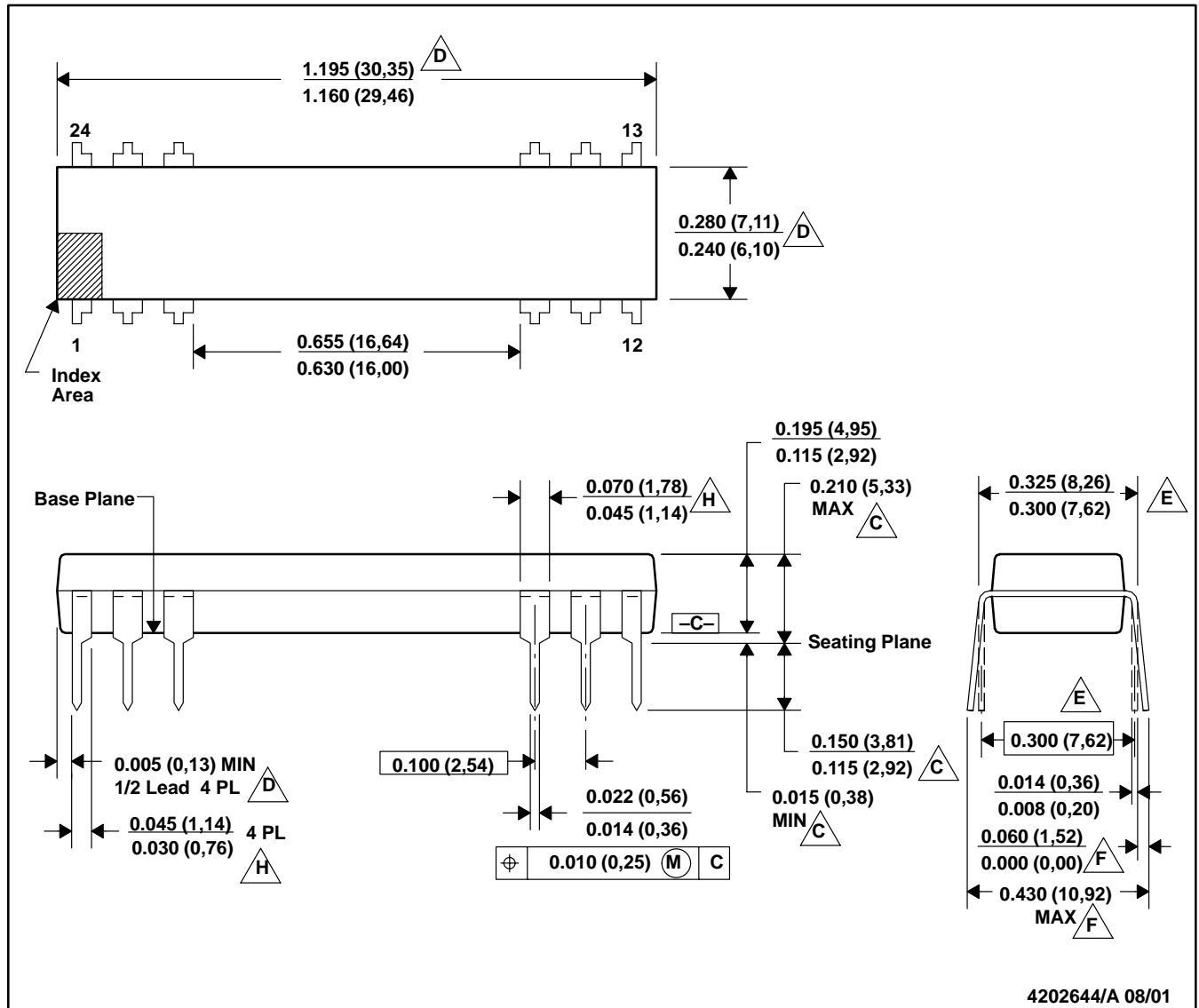

- NOTES:
- All linear dimensions are in inches (millimeters).
 - This drawing is subject to change without notice.
 - Dimensions are measured with the package seated in JEDEC seating plane gauge GS-3.
 - Dimensions do not include mold flash or protrusions. Mold flash or protrusions shall not exceed 0.010 (0,25).
 - Dimensions measured with the leads constrained to be perpendicular to Datum C.
 - Dimensions are measured at the lead tips with the leads unconstrained.
 - Pointed or rounded lead tips are preferred to ease insertion.
 - Maximum dimensions do not include dambar protrusions. Dambar protrusions shall not exceed 0.010 (0,25).
 - Distance between leads including dambar protrusions to be 0.005 (0,13) minimum.
 - A visual index feature must be located within the cross-hatched area.
 - For automatic insertion, any raised irregularity on the top surface (step, mesa, etc.) shall be symmetrical about the lateral and longitudinal package centerlines.
 - Controlling dimension in inches.
 - Falls within JEDEC-MS-001-BE with exception of lead count.

DVA (R-PDSO-G8/28)

PLASTIC SMALL-OUTLINE

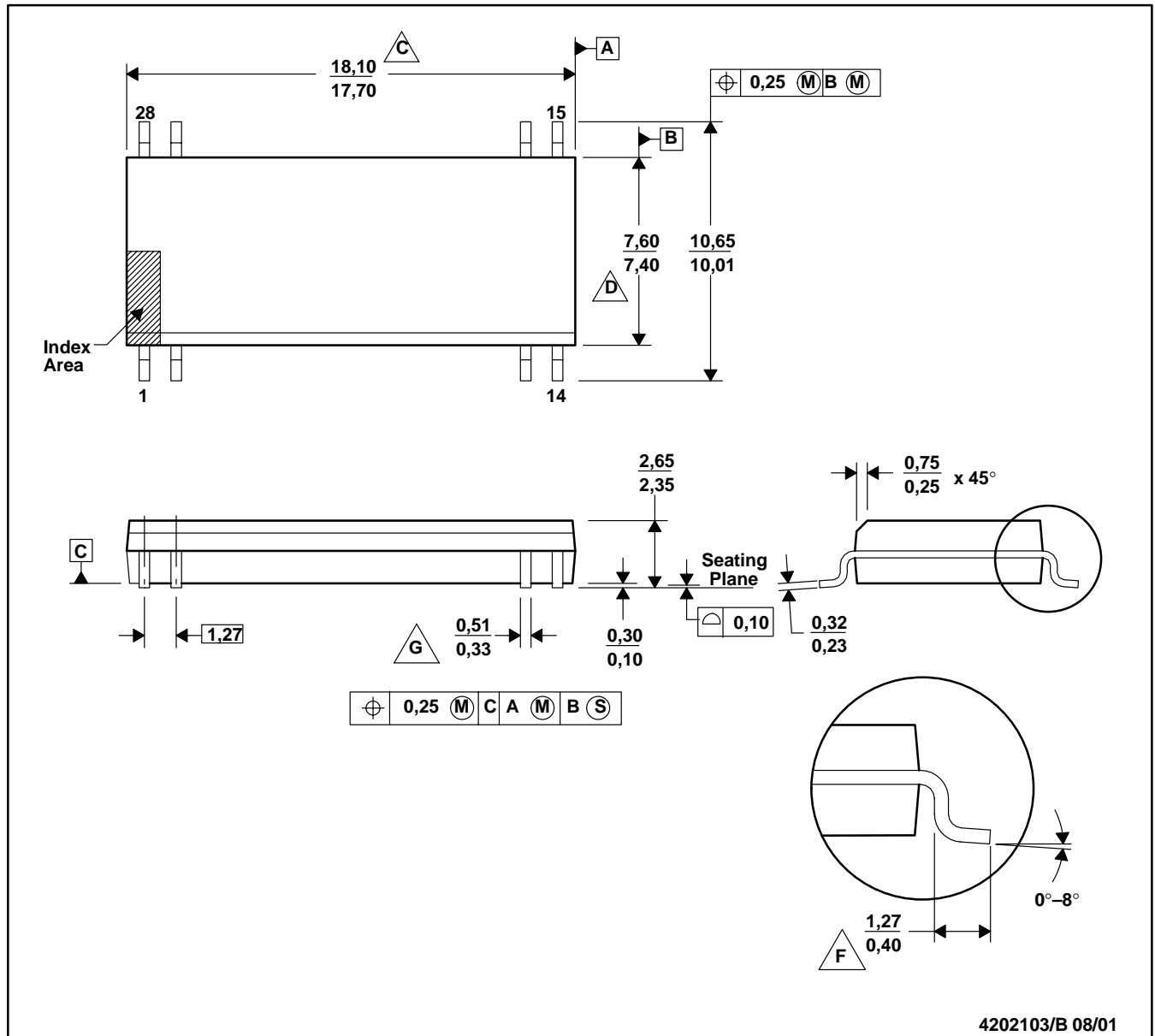

- NOTES: A. All linear dimensions are in millimeters.
 B. This drawing is subject to change without notice.
 C. Body length dimension does not include mold flash, protrusions, or gate burrs. Mold flash, protrusions, and gate burrs shall not exceed 0,15 mm per side.
 D. Body width dimension does not include inter-lead flash or protrusions. Inter-lead flash and protrusions shall not exceed 0,25 mm per side.
 E. The chamfer on the body is optional. If it is not present, a visual index feature must be located within the cross-hatched area.
 F. Lead dimension is the length of terminal for soldering to a substrate.

- G. Lead width, as measured 0,36 mm or greater above the seating plane, shall not exceed a maximum value of 0,61 mm.
 H. Lead-to-lead coplanarity shall be less than 0,10 mm from seating plane.
 I. Falls within JEDEC MS-013-AE with the exception of the number of leads.

DVB0012A



PACKAGE OUTLINE

SOP - 2.65 mm max height

PLASTIC SMALL OUTLINE

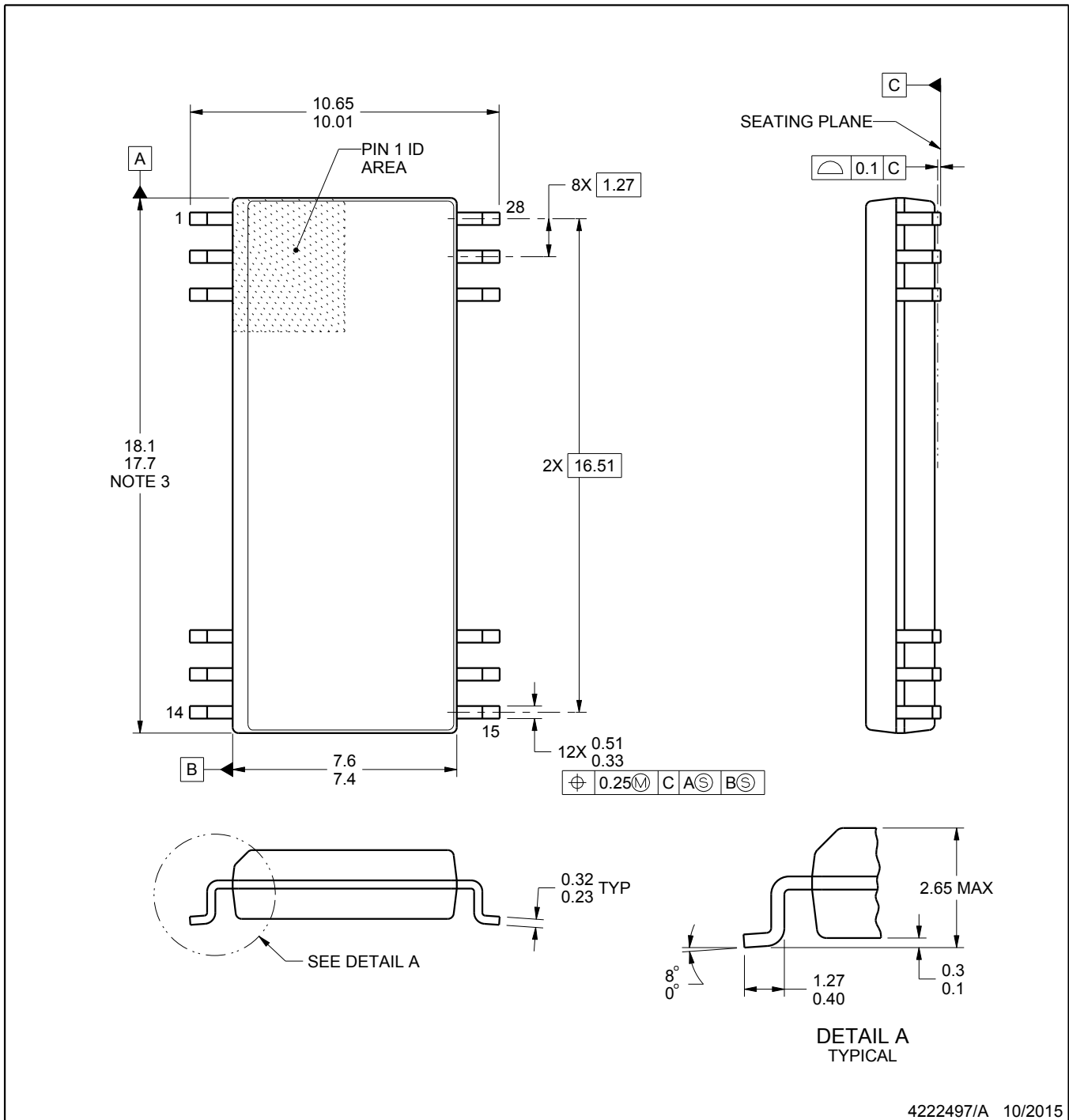

4222497/A 10/2015

NOTES:

1. All linear dimensions are in millimeters. Dimensions in parenthesis are for reference only. Dimensioning and tolerancing per ASME Y14.5M.
2. This drawing is subject to change without notice.
3. This dimension does not include mold flash, protrusions, or gate burrs. Mold flash, protrusions, or gate burrs shall not exceed 0.15 mm per side.
4. Reference JEDEC registration MS-013.

EXAMPLE BOARD LAYOUT

DVB0012A

SOP - 2.65 mm max height

PLASTIC SMALL OUTLINE

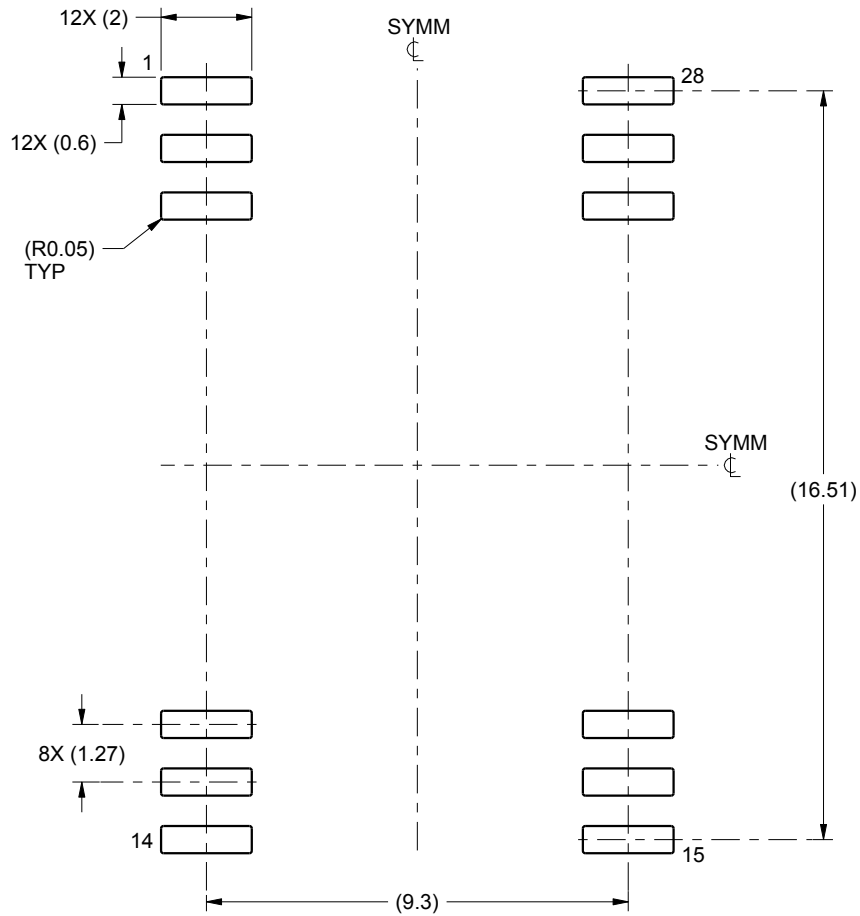

LAND PATTERN EXAMPLE
SCALE:6X

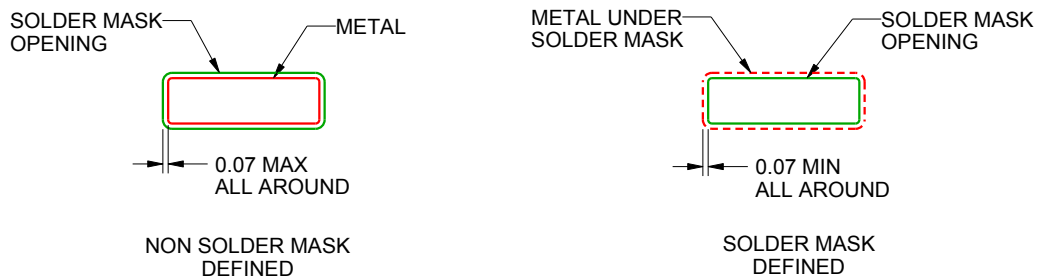

SOLDER MASK DETAILS

4222497/A 10/2015

NOTES: (continued)

5. Publication IPC-7351 may have alternate designs.
6. Solder mask tolerances between and around signal pads can vary based on board fabrication site.

EXAMPLE STENCIL DESIGN

DVB0012A

SOP - 2.65 mm max height

PLASTIC SMALL OUTLINE

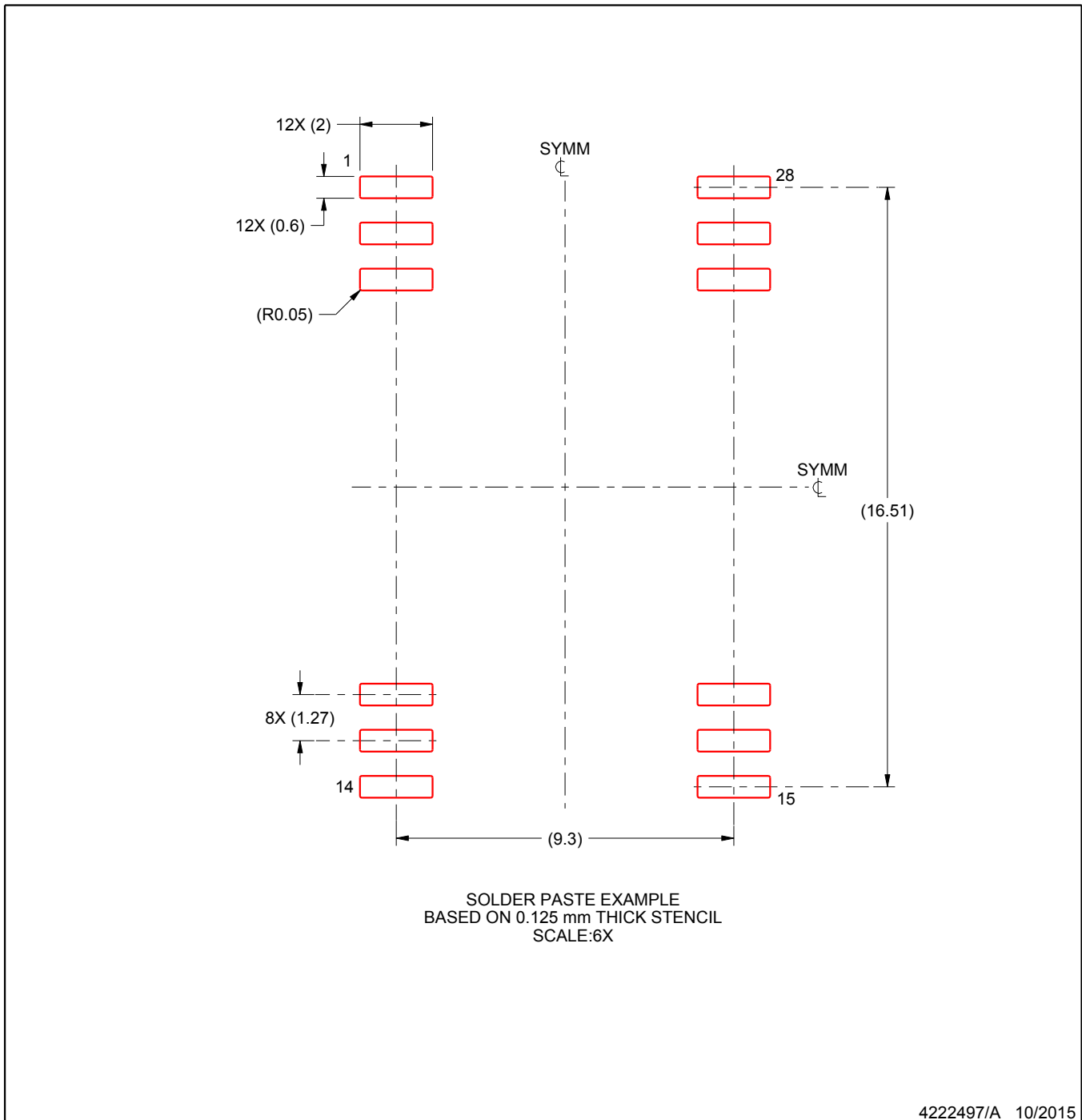

NOTES: (continued)

7. Laser cutting apertures with trapezoidal walls and rounded corners may offer better paste release. IPC-7525 may have alternate design recommendations.
8. Board assembly site may have different recommendations for stencil design.

IMPORTANT NOTICE

Texas Instruments Incorporated and its subsidiaries (TI) reserve the right to make corrections, enhancements, improvements and other changes to its semiconductor products and services per JESD46, latest issue, and to discontinue any product or service per JESD48, latest issue. Buyers should obtain the latest relevant information before placing orders and should verify that such information is current and complete. All semiconductor products (also referred to herein as "components") are sold subject to TI's terms and conditions of sale supplied at the time of order acknowledgment.

TI warrants performance of its components to the specifications applicable at the time of sale, in accordance with the warranty in TI's terms and conditions of sale of semiconductor products. Testing and other quality control techniques are used to the extent TI deems necessary to support this warranty. Except where mandated by applicable law, testing of all parameters of each component is not necessarily performed.

TI assumes no liability for applications assistance or the design of Buyers' products. Buyers are responsible for their products and applications using TI components. To minimize the risks associated with Buyers' products and applications, Buyers should provide adequate design and operating safeguards.

TI does not warrant or represent that any license, either express or implied, is granted under any patent right, copyright, mask work right, or other intellectual property right relating to any combination, machine, or process in which TI components or services are used. Information published by TI regarding third-party products or services does not constitute a license to use such products or services or a warranty or endorsement thereof. Use of such information may require a license from a third party under the patents or other intellectual property of the third party, or a license from TI under the patents or other intellectual property of TI.

Reproduction of significant portions of TI information in TI data books or data sheets is permissible only if reproduction is without alteration and is accompanied by all associated warranties, conditions, limitations, and notices. TI is not responsible or liable for such altered documentation. Information of third parties may be subject to additional restrictions.

Resale of TI components or services with statements different from or beyond the parameters stated by TI for that component or service voids all express and any implied warranties for the associated TI component or service and is an unfair and deceptive business practice. TI is not responsible or liable for any such statements.

Buyer acknowledges and agrees that it is solely responsible for compliance with all legal, regulatory and safety-related requirements concerning its products, and any use of TI components in its applications, notwithstanding any applications-related information or support that may be provided by TI. Buyer represents and agrees that it has all the necessary expertise to create and implement safeguards which anticipate dangerous consequences of failures, monitor failures and their consequences, lessen the likelihood of failures that might cause harm and take appropriate remedial actions. Buyer will fully indemnify TI and its representatives against any damages arising out of the use of any TI components in safety-critical applications.

In some cases, TI components may be promoted specifically to facilitate safety-related applications. With such components, TI's goal is to help enable customers to design and create their own end-product solutions that meet applicable functional safety standards and requirements. Nonetheless, such components are subject to these terms.

No TI components are authorized for use in FDA Class III (or similar life-critical medical equipment) unless authorized officers of the parties have executed a special agreement specifically governing such use.

Only those TI components which TI has specifically designated as military grade or "enhanced plastic" are designed and intended for use in military/aerospace applications or environments. Buyer acknowledges and agrees that any military or aerospace use of TI components which have **not** been so designated is solely at the Buyer's risk, and that Buyer is solely responsible for compliance with all legal and regulatory requirements in connection with such use.

TI has specifically designated certain components as meeting ISO/TS16949 requirements, mainly for automotive use. In any case of use of non-designated products, TI will not be responsible for any failure to meet ISO/TS16949.

Products

Audio	www.ti.com/audio
Amplifiers	amplifier.ti.com
Data Converters	dataconverter.ti.com
DLP® Products	www.dlp.com
DSP	dsp.ti.com
Clocks and Timers	www.ti.com/clocks
Interface	interface.ti.com
Logic	logic.ti.com
Power Mgmt	power.ti.com
Microcontrollers	microcontroller.ti.com
RFID	www.ti-rfid.com
OMAP Applications Processors	www.ti.com/omap
Wireless Connectivity	www.ti.com/wirelessconnectivity

Applications

Automotive and Transportation	www.ti.com/automotive
Communications and Telecom	www.ti.com/communications
Computers and Peripherals	www.ti.com/computers
Consumer Electronics	www.ti.com/consumer-apps
Energy and Lighting	www.ti.com/energy
Industrial	www.ti.com/industrial
Medical	www.ti.com/medical
Security	www.ti.com/security
Space, Avionics and Defense	www.ti.com/space-avionics-defense
Video and Imaging	www.ti.com/video

TI E2E Community

e2e.ti.com