



1-Mbps QUAD DIGITAL ISOLATORS

Check for Samples: [ISO7241A-EP](#)

FEATURES

- 4000- V_{peak} Isolation, 560- V_{peak} V_{IORM}
 - UL 1577, IEC 60747-5-2 (VDE 0884, Rev 2), IEC 61010-1, IEC 60950-1 and CSA Approved
- 4-kV ESD Protection
- Operates With 3.3-V or 5-V Supplies
- Typical 25-Year Life at Rated Working Voltage (See Application Note ([SLLA197](#)) and [Figure 10](#))
- High Electromagnetic Immunity (See Application Report ([SLLA181](#)))

APPLICATIONS

- Industrial Fieldbus
- Computer Peripheral Interface
- Servo Control Interface
- Data Acquisition

SUPPORTS DEFENSE, AEROSPACE, AND MEDICAL APPLICATIONS

- Controlled Baseline
- One Assembly/Test Site
- One Fabrication Site
- Available in Military ($-55^{\circ}\text{C}/125^{\circ}\text{C}$) Temperature Range⁽¹⁾
- Extended Product Life Cycle
- Extended Product-Change Notification
- Product Traceability

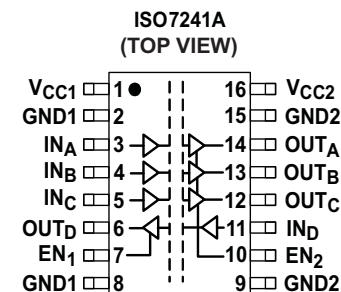

(1) Additional temperature ranges available - contact factory

DESCRIPTION

See the [Product Notification](#) section. The ISO7241A is a quad-channel digital isolator with multiple channel configurations and output enable functions. This device has logic input and output buffers separated by TI's silicon dioxide (SiO_2) isolation barrier. Used in conjunction with isolated power supplies, this device blocks high voltage, isolate grounds, and prevent noise currents from entering the local ground and interfering with or damaging sensitive circuitry.

The ISO7241A has three channels the same direction and one channel in opposition.

This device has TTL input thresholds and a noise-filter at the input that prevents transient pulses from being passed to the output of the device.

A periodic update pulse is sent across the barrier to ensure the proper dc level of the output. If this dc-refresh pulse is not received, the input is assumed to be unpowered or not being actively driven, and the failsafe circuit drives the output to a logic high state. (See ISO7240CF ([SLLS869](#)) or contact TI for a logic low failsafe option).

The ISO7241A may be powered from either 3.3-V or 5-V supplies on either side in any 3.3-V / 3.3-V, 5-V / 5-V, 5-V / 3.3-V, or 3.3-V / 5-V combination. Note that the signal input pins are 5-V tolerant regardless of the voltage supply level being used.

This device is characterized for operation over the ambient temperature range of -55°C to 125°C .



Please be aware that an important notice concerning availability, standard warranty, and use in critical applications of Texas Instruments semiconductor products and disclaimers thereto appears at the end of this data sheet.



This integrated circuit can be damaged by ESD. Texas Instruments recommends that all integrated circuits be handled with appropriate precautions. Failure to observe proper handling and installation procedures can cause damage.

ESD damage can range from subtle performance degradation to complete device failure. Precision integrated circuits may be more susceptible to damage because very small parametric changes could cause the device not to meet its published specifications.

FUNCTION DIAGRAM

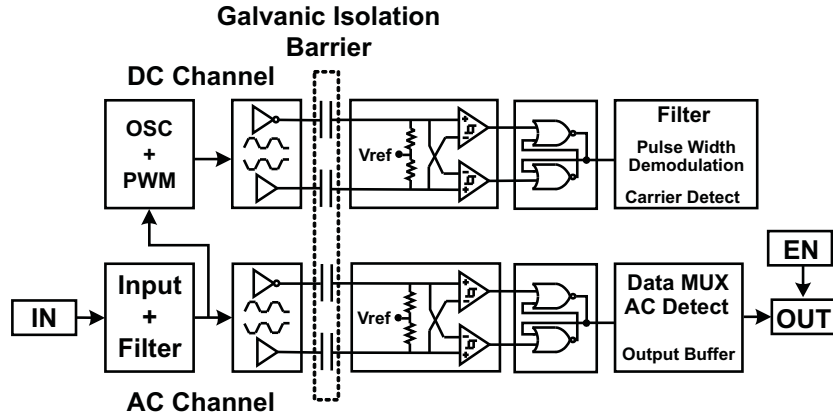

Table 1. Device Function Table⁽¹⁾

INPUT V_{CC}	OUTPUT V_{CC}	INPUT (IN)	OUTPUT ENABLE (EN)	OUTPUT (OUT)
PU	PU	H	H or Open	H
		L	H or Open	L
		X	L	Z
		Open	H or Open	H
PD	PU	X	H or Open	H
PD	PU	X	L	Z

(1) PU = Powered Up; PD = Powered Down ; X = Irrelevant; H = High Level; L = Low Level

Table 2. ORDERING INFORMATION⁽¹⁾

T_A	PACKAGE ⁽²⁾		ORDERABLE PART NUMBER	TOP-SIDE MARKING
-55°C to 125°C	DW	Reel	ISO7241AMDWREP	ISO7241AM

(1) For the most current package and ordering information, see the Package Option Addendum at the end of this document, or see the TI Web site at www.ti.com.

(2) Package drawings, standard packing quantities, thermal data, symbolization, and PCB design guidelines are available at www.ti.com/sc/package.

ABSOLUTE MAXIMUM RATINGS⁽¹⁾

			VALUE	UNIT		
V _{CC}	Supply voltage ⁽²⁾ , V _{CC1} , V _{CC2}		-0.5 to 6	V		
V _I	Voltage at IN, OUT, EN		-0.5 to 6	V		
I _O	Output current		±15	mA		
ESD	Electrostatic discharge	Human Body Model	JEDEC Standard 22, Test Method A114-C.01	All pins	±4	kV
		Field-Induced-Charged Device Model	JEDEC Standard 22, Test Method C101		±1	
		Machine Model	ANSI/ESDS5.2-1996		±200	
T _J	Maximum junction temperature		170	°C		

- (1) Stresses beyond those listed under *absolute maximum ratings* may cause permanent damage to the device. These are stress ratings only and functional operation of the device at these or any other conditions beyond those indicated under *recommended operating conditions* is not implied. Exposure to absolute-maximum-rated conditions for extended periods may affect device reliability.
- (2) All voltage values are with respect to network ground terminal and are peak voltage values.

RECOMMENDED OPERATING CONDITIONS

		MIN	TYP	MAX	UNIT
V _{CC}	Supply voltage ⁽¹⁾ , V _{CC1} , V _{CC2}	3.15		5.5	V
I _{OH}	High-level output current			4	mA
I _{OL}	Low-level output current	-4			mA
t _{ui}	Input pulse width	1			µs
1/t _{ui}	Signaling rate	0		1000	kbps
V _{IH}	High-level input voltage (IN) (EN on all devices)	2		V _{CC}	V
V _{IL}	Low-level input voltage (IN) (EN on all devices)	0		0.8	V
T _J	Junction temperature			150	°C
H	External magnetic field-strength immunity per IEC 61000-4-8 and IEC 61000-4-9 certification			1000	A/m

- (1) For the 5-V operation, V_{CC1} or V_{CC2} is specified from 4.5 V to 5.5 V.
For the 3-V operation, V_{CC1} or V_{CC2} is specified from 3.15 V to 3.6 V.

ELECTRICAL CHARACTERISTICS: V_{CC1} and V_{CC2} at 5-V⁽¹⁾ OPERATION

, over recommended operating conditions (unless otherwise noted)

PARAMETER		TEST CONDITIONS	MIN	TYP	MAX	UNIT
SUPPLY CURRENT						
I_{CC1}	Quiescent	$V_I = V_{CC}$ or 0 V, All channels, no load, EN_1 at 3 V, EN_2 at 3 V		6.5	11	mA
	1 Mbps					
I_{CC2}	Quiescent	$V_I = V_{CC}$ or 0 V, All channels, no load, EN_1 at 3 V, EN_2 at 3 V		13	20	mA
	1 Mbps					
ELECTRICAL CHARACTERISTICS						
I_{OFF}	Sleep mode output current	EN at 0 V, Single channel		0		μ A
V_{OH}	High-level output voltage	$I_{OH} = -4$ mA, See Figure 1	$V_{CC} - 0.8$			V
		$I_{OH} = -20$ μ A, See Figure 1	$V_{CC} - 0.1$			
V_{OL}	Low-level output voltage	$I_{OL} = 4$ mA, See Figure 1			0.4	V
		$I_{OL} = 20$ μ A, See Figure 1			0.1	
$V_{I(HYS)}$	Input voltage hysteresis			150		mV
I_{IH}	High-level input current	IN from 0 V to V_{CC}			10	μ A
I_{IL}	Low-level input current				-10	
C_1	Input capacitance to ground	IN at V_{CC} , $V_I = 0.4 \sin(4E6\pi t)$			2	pF
CMTI	Common-mode transient immunity	$V_I = V_{CC}$ or 0 V, See Figure 4	25	50		kV/ μ s

- (1) For the 5-V operation, V_{CC1} or V_{CC2} is specified from 4.5 V to 5.5 V.
For the 3-V operation, V_{CC1} or V_{CC2} is specified from 3.15 V to 3.6 V.

SWITCHING CHARACTERISTICS: V_{CC1} and V_{CC2} at 5-V OPERATION

over recommended operating conditions (unless otherwise noted)

PARAMETER		TEST CONDITIONS	MIN	TYP	MAX	UNIT
t_{PLH} , t_{PHL}	Propagation delay	See Figure 1	40		95	ns
PWD	Pulse-width distortion ⁽¹⁾ $ t_{PHL} - t_{PLH} $					
$t_{sk(o)}$	Channel-to-channel output skew ⁽²⁾				2	ns
t_r	Output signal rise time	See Figure 1			2	ns
t_f	Output signal fall time					
t_{PHZ}	Propagation delay, high-level-to-high-impedance output	See Figure 2			15	20
t_{PZH}	Propagation delay, high-impedance-to-high-level output					
t_{PLZ}	Propagation delay, low-level-to-high-impedance output					
t_{PZL}	Propagation delay, high-impedance-to-low-level output					
t_{fs}	Failsafe output delay time from input power loss	See Figure 3			12	μ s

- (1) Also referred to as pulse skew.
(2) $t_{sk(o)}$ is the skew between specified outputs of a single device with all driving inputs connected together and the outputs switching in the same direction while driving identical specified loads.

ELECTRICAL CHARACTERISTICS: V_{CC1} at 5-V, V_{CC2} at 3.3-V⁽¹⁾ OPERATION

over recommended operating conditions (unless otherwise noted)

PARAMETER		TEST CONDITIONS	MIN	TYP	MAX	UNIT
SUPPLY CURRENT						
I_{CC1}	Quiescent	$V_1 = V_{CC}$ or 0 V, All channels, no load, EN ₁ at 3 V, EN ₂ at 3 V		6.5	11	mA
	1 Mbps					
I_{CC2}	Quiescent	$V_1 = V_{CC}$ or 0 V, All channels, no load, EN ₁ at 3 V, EN ₂ at 3 V		8	13	mA
	1 Mbps			8	13	
ELECTRICAL CHARACTERISTICS						
I_{OFF}	Sleep mode output current	EN at 0 V, Single channel		0		μ A
V_{OH}	High-level output voltage	$I_{OH} = -4$ mA, See Figure 1	(5-V side)		$V_{CC} - 0.8$	V
		$I_{OH} = -20$ μ A, See Figure 1			$V_{CC} - 0.1$	
V_{OL}	Low-level output voltage	$I_{OL} = 4$ mA, See Figure 1			0.4	V
		$I_{OL} = 20$ μ A, See Figure 1			0.1	
$V_{I(HYS)}$	Input voltage hysteresis		150			mV
I_{IH}	High-level input current	IN from 0 V to V_{CC}			10	μ A
I_{IL}	Low-level input current		-10			
C_1	Input capacitance to ground	IN at V_{CC} , $V_I = 0.4 \sin(4E6\pi t)$	2			pF
CMTI	Common-mode transient immunity	$V_1 = V_{CC}$ or 0 V, See Figure 4	25	50		kV/ μ s

- (1) For the 5-V operation, V_{CC1} or V_{CC2} is specified from 4.5 V to 5.5 V.
For the 3-V operation, V_{CC1} or V_{CC2} is specified from 3.15 V to 3.6 V.

SWITCHING CHARACTERISTICS: V_{CC1} at 5-V, V_{CC2} at 3.3-V OPERATION

over recommended operating conditions (unless otherwise noted)

PARAMETER		TEST CONDITIONS	MIN	TYP	MAX	UNIT
t_{PLH} , t_{PHL}	Propagation delay	See Figure 1	40		100	ns
PWD	Pulse-width distortion ⁽¹⁾ $ t_{PHL} - t_{PLH} $				11	
$t_{sk(o)}$	Channel-to-channel output skew ⁽²⁾				3	ns
t_r	Output signal rise time	See Figure 1		2		ns
t_f	Output signal fall time			2		
t_{PHZ}	Propagation delay, high-level-to-high-impedance output	See Figure 2		15	20	ns
t_{PZH}	Propagation delay, high-impedance-to-high-level output			15	20	
t_{PLZ}	Propagation delay, low-level-to-high-impedance output			15	20	
t_{PZL}	Propagation delay, high-impedance-to-low-level output			15	20	
t_{fs}	Failsafe output delay time from input power loss	See Figure 3		18		μ s

- (1) Also known as pulse skew
(2) $t_{sk(o)}$ is the skew between specified outputs of a single device with all driving inputs connected together and the outputs switching in the same direction while driving identical specified loads.

ELECTRICAL CHARACTERISTICS: V_{CC1} at 3.3-V, V_{CC2} at 5-V⁽¹⁾ OPERATION

over recommended operating conditions (unless otherwise noted)

PARAMETER		TEST CONDITIONS	MIN	TYP	MAX	UNIT
SUPPLY CURRENT						
I_{CC1}	Quiescent	$V_I = V_{CC}$ or 0 V, All channels, no load, EN ₁ at 3 V, EN ₂ at 3 V		4	7	mA
	1 Mbps			4	7	
I_{CC2}	Quiescent	$V_I = V_{CC}$ or 0 V, All channels, no load, EN ₁ at 3 V, EN ₂ at 3 V		13	20	mA
	1 Mbps			13	20	
ELECTRICAL CHARACTERISTICS						
I_{OFF}	Sleep mode output current	EN at V_{CC} , Single channel		0		μ A
V_{OH}	High-level output voltage	$I_{OH} = -4$ mA, See Figure 1	(5-V side)		$V_{CC} - 0.8$	V
		$I_{OH} = -20$ μ A, See Figure 1			$V_{CC} - 0.1$	
V_{OL}	Low-level output voltage	$I_{OL} = 4$ mA, See Figure 1			0.4	V
		$I_{OL} = 20$ μ A, See Figure 1			0.1	
$V_{I(HYS)}$	Input voltage hysteresis				150	mV
I_{IH}	High-level input current	IN from 0 V to V_{CC}			10	μ A
I_{IL}	Low-level input current				-10	
C_1	Input capacitance to ground	IN at V_{CC} , $V_I = 0.4 \sin(4E6\pi t)$			2	pF
CMTI	Common-mode transient immunity	$V_I = V_{CC}$ or 0 V, See Figure 4	25	50		kV/ μ s

- (1) For the 5-V operation, V_{CC1} or V_{CC2} is specified from 4.5 V to 5.5 V.
 For the 3-V operation, V_{CC1} or V_{CC2} is specified from 3.15 V to 3.6 V.

SWITCHING CHARACTERISTICS: V_{CC1} at 3.3-V and V_{CC2} at 5-V OPERATION

over recommended operating conditions (unless otherwise noted)

PARAMETER		TEST CONDITIONS	MIN	TYP	MAX	UNIT
t_{PLH} , t_{PHL}	Propagation delay	See Figure 1	40		100	ns
PWD	Pulse-width distortion ⁽¹⁾ $ t_{PHL} - t_{PLH} $				11	
$t_{sk(o)}$	Channel-to-channel output skew ⁽²⁾			2.5	ns	
t_r	Output signal rise time	See Figure 1		2		ns
t_f	Output signal fall time			2		
t_{PHZ}	Propagation delay, high-level-to-high-impedance output	See Figure 2		15	20	ns
t_{PZH}	Propagation delay, high-impedance-to-high-level output			15	20	
t_{PLZ}	Propagation delay, low-level-to-high-impedance output			15	20	
t_{PZL}	Propagation delay, high-impedance-to-low-level output			15	20	
t_{fs}	Failsafe output delay time from input power loss	See Figure 3		12		μ s

- (1) Also known as pulse skew
 (2) $t_{sk(o)}$ is the skew between specified outputs of a single device with all driving inputs connected together and the outputs switching in the same direction while driving identical specified loads.

ELECTRICAL CHARACTERISTICS: V_{CC1} and V_{CC2} at 3.3 V⁽¹⁾ OPERATION

over recommended operating conditions (unless otherwise noted)

PARAMETER		TEST CONDITIONS	MIN	TYP	MAX	UNIT
SUPPLY CURRENT						
I_{CC1}	Quiescent	$V_1 = V_{CC}$ or 0 V, all channels, no load, EN ₁ at 3 V, EN ₂ at 3 V		4	7	mA
	1 Mbps			4	7	
I_{CC2}	Quiescent	$V_1 = V_{CC}$ or 0 V, all channels, no load, EN ₁ at 3 V, EN ₂ at 3 V		8	13	mA
	1 Mbps			8	13	
ELECTRICAL CHARACTERISTICS						
I_{OFF}	Sleep mode output current	EN at 0 V, single channel		0		μ A
V_{OH}	High-level output voltage	$I_{OH} = -4$ mA, See Figure 1		$V_{CC} - 0.4$		V
		$I_{OH} = -20$ μ A, See Figure 1		$V_{CC} - 0.1$		
V_{OL}	Low-level output voltage	$I_{OL} = 4$ mA, See Figure 1			0.4	V
		$I_{OL} = 20$ μ A, See Figure 1			0.1	
$V_{I(HYS)}$	Input voltage hysteresis			150		mV
I_{IH}	High-level input current	IN from 0 V or V_{CC}			10	μ A
I_{IL}	Low-level input current			-10		
C_1	Input capacitance to ground	IN at V_{CC} , $V_1 = 0.4 \sin(4E6\pi t)$		2		pF
CMTI	Common-mode transient immunity	$V_1 = V_{CC}$ or 0 V, See Figure 4	25	50		kV/ μ s

- (1) For the 5-V operation, V_{CC1} or V_{CC2} is specified from 4.5 V to 5.5 V.
For the 3-V operation, V_{CC1} or V_{CC2} is specified from 3.15 V to 3.6 V.

SWITCHING CHARACTERISTICS: V_{CC1} and V_{CC2} at 3.3-V OPERATION

over recommended operating conditions (unless otherwise noted)

PARAMETER		TEST CONDITIONS	MIN	TYP	MAX	UNIT
t_{PLH} , t_{PHL}	Propagation delay	See Figure 1	45		110	ns
PWD	Pulse-width distortion $ t_{PHL} - t_{PLH} $ ⁽¹⁾				12	
$t_{sk(o)}$	Channel-to-channel output skew ⁽²⁾				3.5	ns
t_r	Output signal rise time	See Figure 1		2		
t_f	Output signal fall time				2	
t_{PHZ}	Propagation delay, high-level-to-high-impedance output	See Figure 2		15	20	ns
t_{PZH}	Propagation delay, high-impedance-to-high-level output			15	20	
t_{PLZ}	Propagation delay, low-level-to-high-impedance output			15	20	
t_{PZL}	Propagation delay, high-impedance-to-low-level output			15	20	
t_{fs}	Failsafe output delay time from input power loss	See Figure 3		18		μ s

- (1) Also referred to as pulse skew.
(2) $t_{sk(o)}$ is the skew between specified outputs of a single device with all driving inputs connected together and the outputs switching in the same direction while driving identical specified loads.

PARAMETER MEASUREMENT INFORMATION

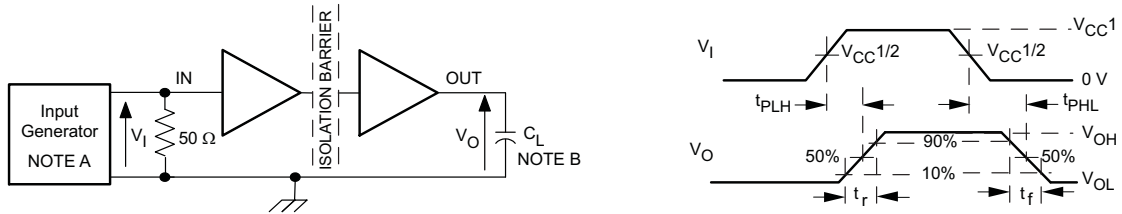

- A. The input pulse is supplied by a generator having the following characteristics: PRR ≤ 50 kHz, 50% duty cycle, $t_r \leq 3$ ns, $t_f \leq 3$ ns, $Z_O = 50\Omega$.
- B. $C_L = 15$ pF and includes instrumentation and fixture capacitance within $\pm 20\%$.

Figure 1. Switching Characteristic Test Circuit and Voltage Waveforms

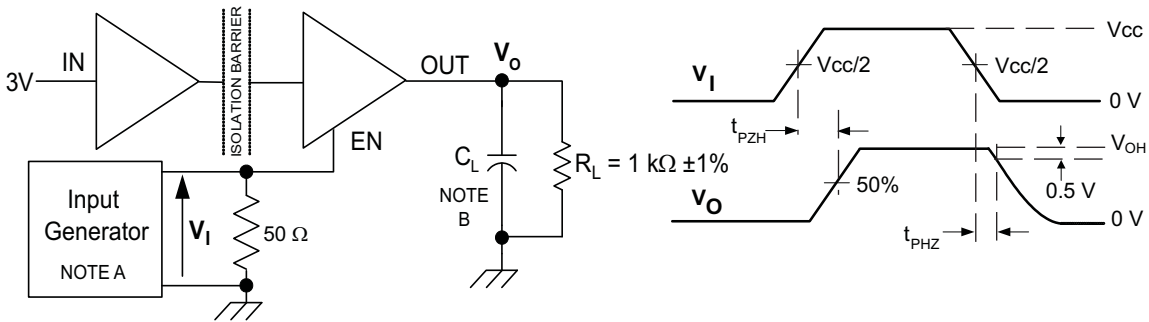
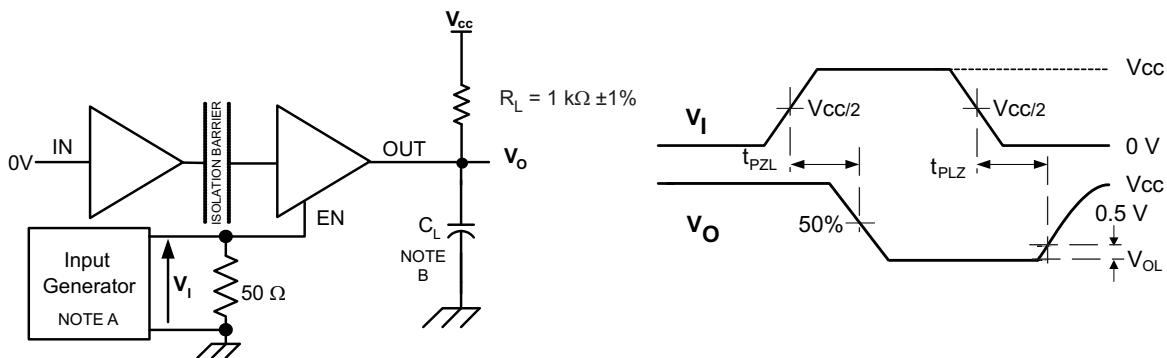

- A. The input pulse is supplied by a generator having the following characteristics: PRR ≤ 50 kHz, 50% duty cycle, $t_r \leq 3$ ns, $t_f \leq 3$ ns, $Z_O = 50\Omega$.
- B. $C_L = 15$ pF and includes instrumentation and fixture capacitance within $\pm 20\%$.

Figure 2. Enable/Disable Propagation Delay Time Test Circuit and Waveform

PARAMETER MEASUREMENT INFORMATION (continued)

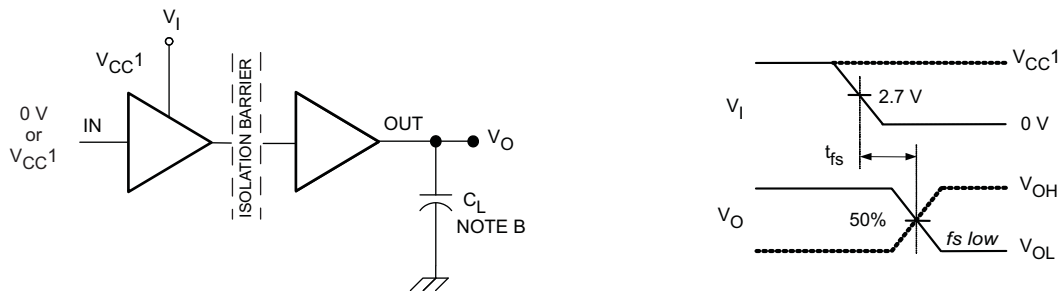

- A. $C_L = 15 \text{ pF}$ and includes instrumentation and fixture capacitance within $\pm 20\%$.
- B. The input pulse is supplied by a generator having the following characteristics: $\text{PRR} \leq 50 \text{ kHz}$, 50% duty cycle, $t_r \leq 3 \text{ ns}$, $t_f \leq 3 \text{ ns}$, $Z_O = 50 \Omega$.

Figure 3. Failsafe Delay Time Test Circuit and Voltage Waveforms

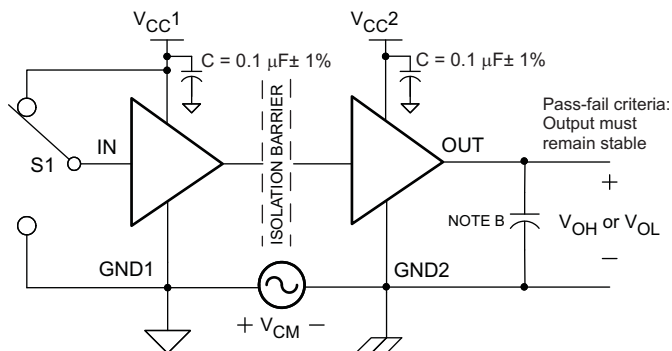

- A. $C_L = 15 \text{ pF}$ and includes instrumentation and fixture capacitance within $\pm 20\%$.
- B. The input pulse is supplied by a generator having the following characteristics: $\text{PRR} \leq 50 \text{ kHz}$, 50% duty cycle, $t_r \leq 3 \text{ ns}$, $t_f \leq 3 \text{ ns}$, $Z_O = 50 \Omega$.

Figure 4. Common-Mode Transient Immunity Test Circuit and Voltage Waveform

DEVICE INFORMATION

PACKAGE CHARACTERISTICS

PARAMETER	TEST CONDITIONS	MIN	TYP	MAX	UNIT
L(I01) Minimum air gap (Clearance)	Shortest terminal-to-terminal distance through air	8.34			mm
L(I02) Minimum external tracking (Creepage)	Shortest terminal-to-terminal distance across the package surface	8.1			mm
Minimum Internal Gap (Internal Clearance)	Distance through the insulation	0.008			mm
R _{IO} Isolation resistance	Input to output, V _{IO} = 500 V, all pins on each side of the barrier tied together creating a two-terminal device	>10 ¹²			Ω
C _{IO} Barrier capacitance Input to output	V _I = 0.4 sin (4E6πt)		2		pF
C _I Input capacitance to ground	V _I = 0.4 sin (4E6πt)		2		pF

DEVICE I/O SCHEMATICS

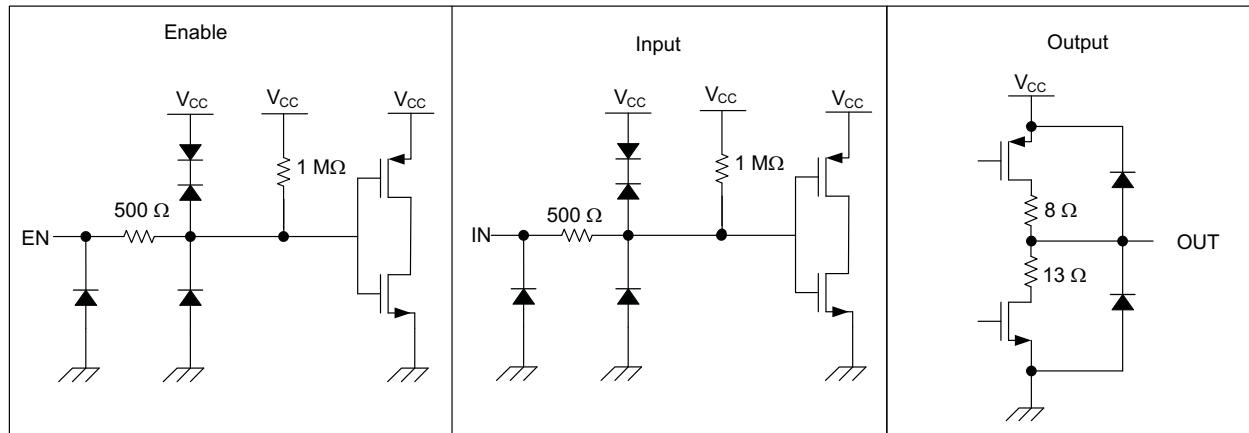

REGULATORY INFORMATION

VDE	CSA	UL
Certified according to IEC 60747-5-2	Approved under CSA Component Acceptance Notice	Recognized under 1577 Component Recognition Program ⁽¹⁾
File Number: 40016131	File Number: 1698195	File Number: E181974

(1) Production tested ≥ 3000 Vrms for 1 second in accordance with UL 1577.

THERMAL CHARACTERISTICS

over recommended operating conditions (unless otherwise noted)

PARAMETER	TEST CONDITIONS	MIN	TYP	MAX	UNIT
θ _{JA} Junction-to-air	Low-K Thermal Resistance ⁽¹⁾		168		°C/W
	High-K Thermal Resistance		96.1		
θ _{JB} Junction-to-Board Thermal Resistance			61		°C/W
θ _{JC} Junction-to-Case Thermal Resistance			48		°C/W
P _D Device Power Dissipation	V _{CC1} = V _{CC2} = 5.5 V, T _J = 150°C, C _L = 15 pF, Input a 50% duty cycle square wave			220	mW

(1) Tested in accordance with the Low-K or High-K thermal metric definitions of EIA/JESD51-3 for leaded surface mount packages.

TYPICAL CHARACTERISTIC CURVES

INPUT VOLTAGE THRESHOLD
vs
FREE-AIR TEMPERATURE

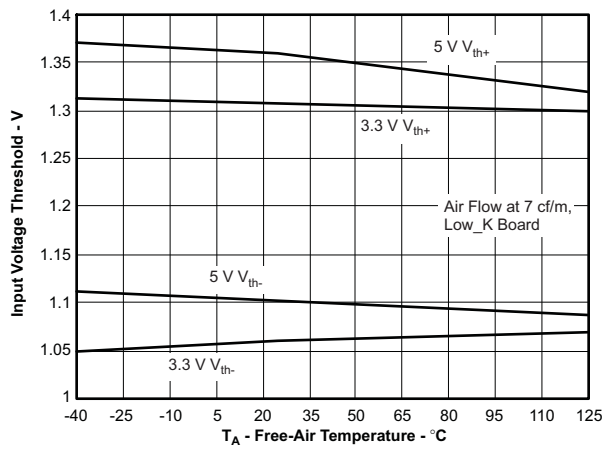

Figure 5.

V_{CC1} FAILSAFE THRESHOLD
vs
FREE-AIR TEMPERATURE

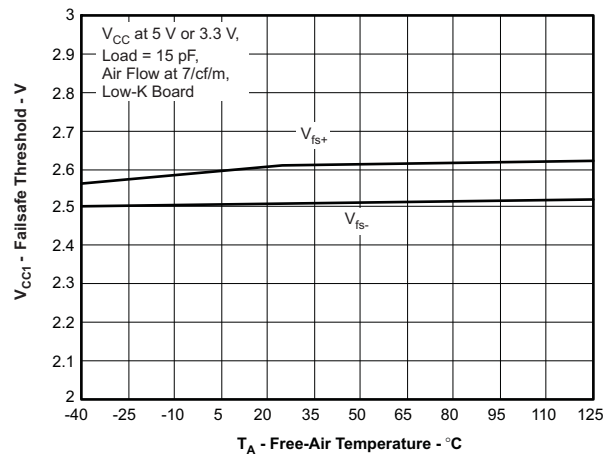

Figure 6.

HIGH-LEVEL OUTPUT CURRENT
vs
HIGH-LEVEL OUTPUT VOLTAGE

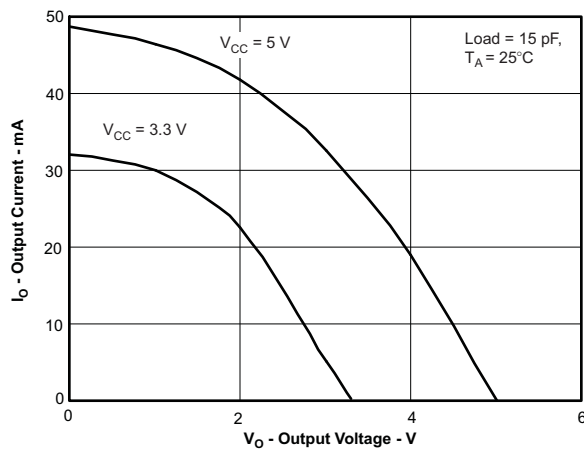

Figure 7.

LOW-LEVEL OUTPUT CURRENT
vs
LOW-LEVEL OUTPUT VOLTAGE

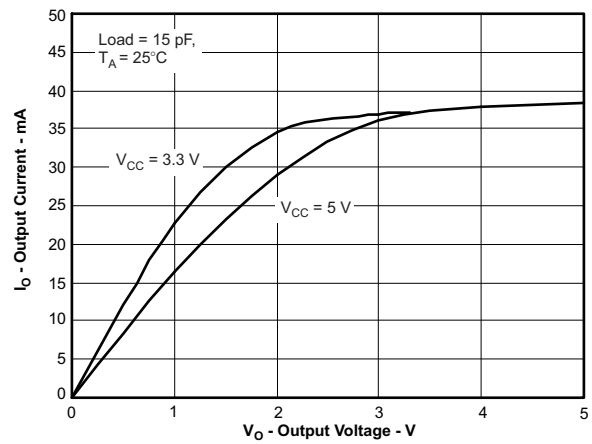

Figure 8.

APPLICATION INFORMATION

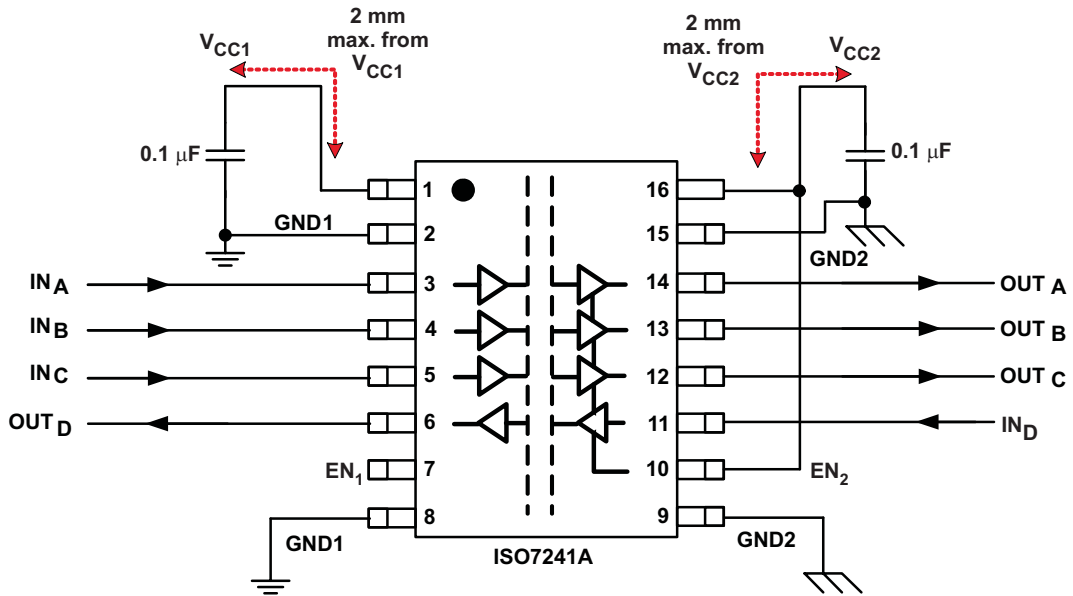

Figure 9. Typical Application Circuit

LIFE EXPECTANCY vs. WORKING VOLTAGE

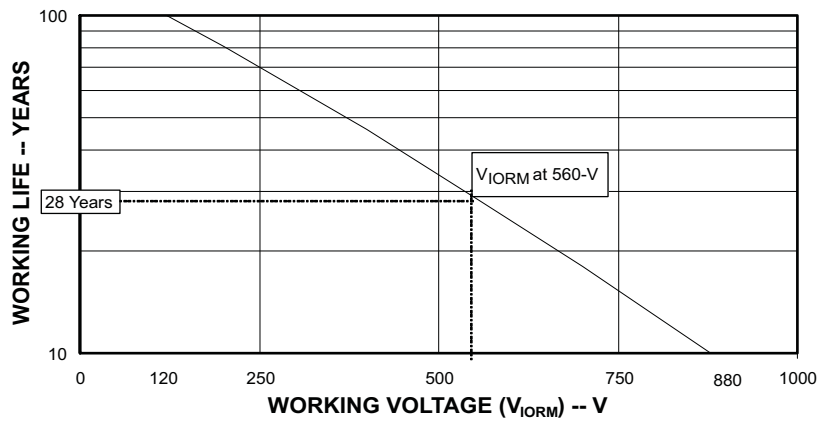

Figure 10. Time-Dependant Dielectric Breakdown Testing Results

PRODUCT NOTIFICATION

An ISO7241A anomaly occurs when a negative-going pulse below the specified 1- μ s minimum bit width is input to the device. The output locks in a logic-low condition until the next rising edge occurs after a 1- μ s period.

Positive noise edges in pulses of less than the minimum specified 1 μ s have no effect on the device, and are properly filtered.

To prevent noise from interfering with ISO7241A performance, it is recommended that an appropriately sized capacitor be placed on each input of the device

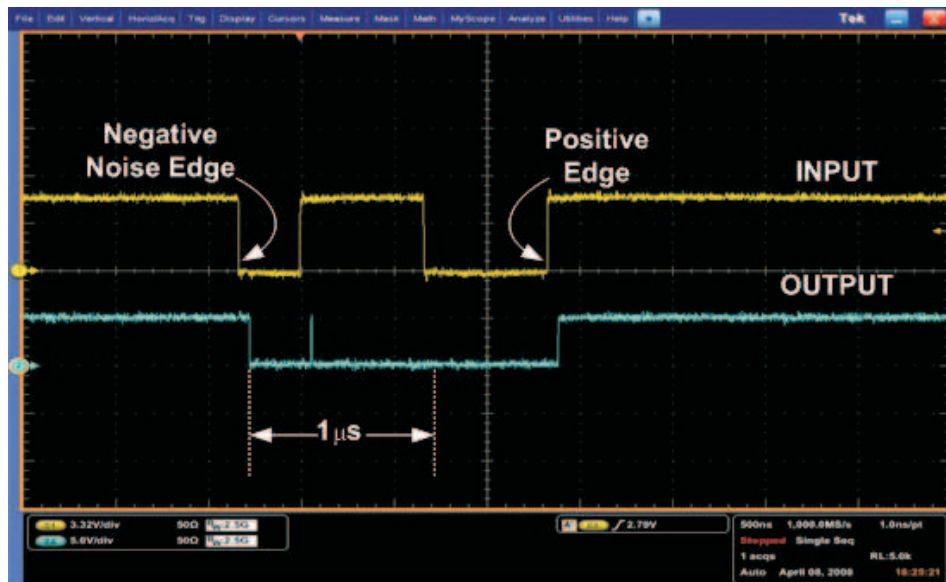

Figure 11. ISO7241A Anomaly

PACKAGING INFORMATION

Orderable Device	Status (1)	Package Type	Package Drawing	Pins	Package Qty	Eco Plan (2)	Lead/Ball Finish (6)	MSL Peak Temp (3)	Op Temp (°C)	Device Marking (4/5)	Samples
ISO7241AMDWREP	ACTIVE	SOIC	DW	16	2000	Green (RoHS & no Sb/Br)	CU NIPDAU	Level-3-260C-168 HR	-55 to 125	ISO7241AM	Samples
V62/10606-01XE	ACTIVE	SOIC	DW	16	2000	Green (RoHS & no Sb/Br)	CU NIPDAU	Level-3-260C-168 HR	-55 to 125	ISO7241AM	Samples

(1) The marketing status values are defined as follows:

ACTIVE: Product device recommended for new designs.

LIFEBUY: TI has announced that the device will be discontinued, and a lifetime-buy period is in effect.

NRND: Not recommended for new designs. Device is in production to support existing customers, but TI does not recommend using this part in a new design.

PREVIEW: Device has been announced but is not in production. Samples may or may not be available.

OBsolete: TI has discontinued the production of the device.

(2) Eco Plan - The planned eco-friendly classification: Pb-Free (RoHS), Pb-Free (RoHS Exempt), or Green (RoHS & no Sb/Br) - please check <http://www.ti.com/productcontent> for the latest availability information and additional product content details.

TBD: The Pb-Free/Green conversion plan has not been defined.

Pb-Free (RoHS): TI's terms "Lead-Free" or "Pb-Free" mean semiconductor products that are compatible with the current RoHS requirements for all 6 substances, including the requirement that lead not exceed 0.1% by weight in homogeneous materials. Where designed to be soldered at high temperatures, TI Pb-Free products are suitable for use in specified lead-free processes.

Pb-Free (RoHS Exempt): This component has a RoHS exemption for either 1) lead-based flip-chip solder bumps used between the die and package, or 2) lead-based die adhesive used between the die and leadframe. The component is otherwise considered Pb-Free (RoHS compatible) as defined above.

Green (RoHS & no Sb/Br): TI defines "Green" to mean Pb-Free (RoHS compatible), and free of Bromine (Br) and Antimony (Sb) based flame retardants (Br or Sb do not exceed 0.1% by weight in homogeneous material)

(3) MSL, Peak Temp. - The Moisture Sensitivity Level rating according to the JEDEC industry standard classifications, and peak solder temperature.

(4) There may be additional marking, which relates to the logo, the lot trace code information, or the environmental category on the device.

(5) Multiple Device Markings will be inside parentheses. Only one Device Marking contained in parentheses and separated by a "~" will appear on a device. If a line is indented then it is a continuation of the previous line and the two combined represent the entire Device Marking for that device.

(6) Lead/Ball Finish - Orderable Devices may have multiple material finish options. Finish options are separated by a vertical ruled line. Lead/Ball Finish values may wrap to two lines if the finish value exceeds the maximum column width.

Important Information and Disclaimer: The information provided on this page represents TI's knowledge and belief as of the date that it is provided. TI bases its knowledge and belief on information provided by third parties, and makes no representation or warranty as to the accuracy of such information. Efforts are underway to better integrate information from third parties. TI has taken and continues to take reasonable steps to provide representative and accurate information but may not have conducted destructive testing or chemical analysis on incoming materials and chemicals. TI and TI suppliers consider certain information to be proprietary, and thus CAS numbers and other limited information may not be available for release.

In no event shall TI's liability arising out of such information exceed the total purchase price of the TI part(s) at issue in this document sold by TI to Customer on an annual basis.

OTHER QUALIFIED VERSIONS OF ISO7241A-EP :

- Catalog: [ISO7241A](#)

NOTE: Qualified Version Definitions:

- Catalog - TI's standard catalog product

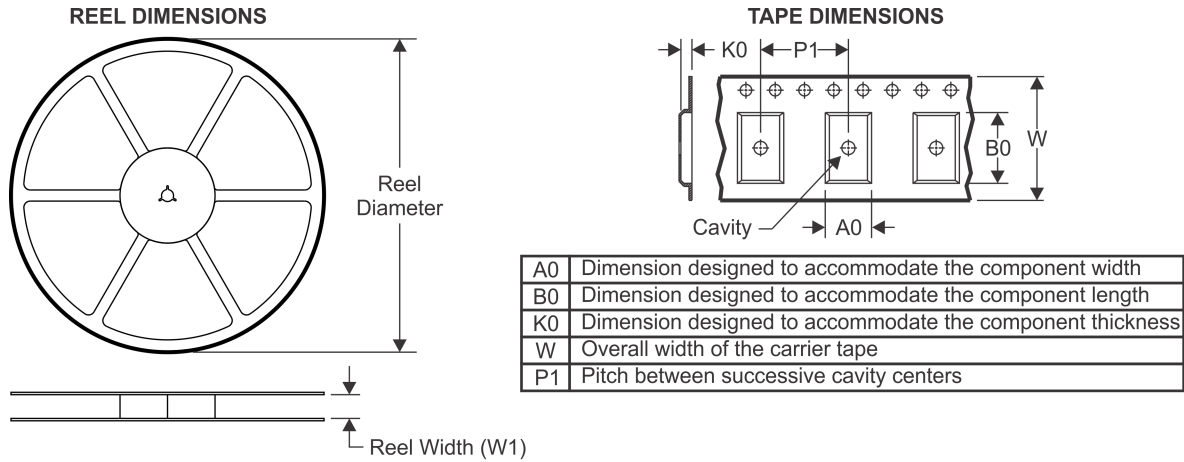
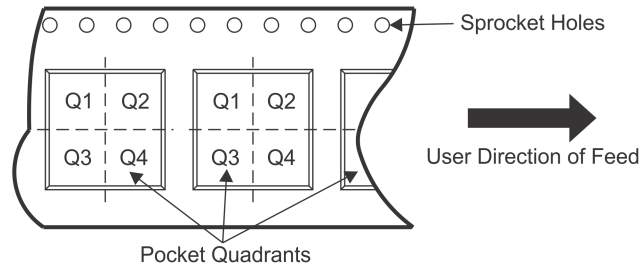
TAPE AND REEL INFORMATION

QUADRANT ASSIGNMENTS FOR PIN 1 ORIENTATION IN TAPE

*All dimensions are nominal

Device	Package Type	Package Drawing	Pins	SPQ	Reel Diameter (mm)	Reel Width W1 (mm)	A0 (mm)	B0 (mm)	K0 (mm)	P1 (mm)	W (mm)	Pin1 Quadrant
ISO7241AMDWREP	SOIC	DW	16	2000	330.0	16.4	10.75	10.7	2.7	12.0	16.0	Q1

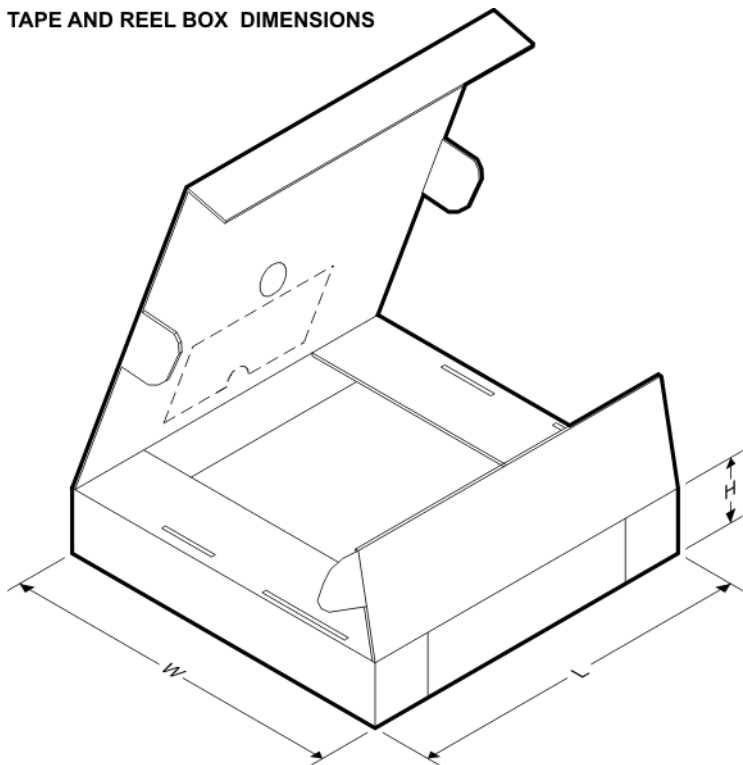
TAPE AND REEL BOX DIMENSIONS



*All dimensions are nominal

Device	Package Type	Package Drawing	Pins	SPQ	Length (mm)	Width (mm)	Height (mm)
ISO7241AMDWREP	SOIC	DW	16	2000	535.4	167.6	48.3

DW (R-PDSO-G16)

PLASTIC SMALL OUTLINE



- NOTES:
- All linear dimensions are in inches (millimeters). Dimensioning and tolerancing per ASME Y14.5M-1994.
 - This drawing is subject to change without notice.
 - Body dimensions do not include mold flash or protrusion not to exceed 0.006 (0,15).
 - Falls within JEDEC MS-013 variation AA.

DW (R-PDSO-G16)

PLASTIC SMALL OUTLINE

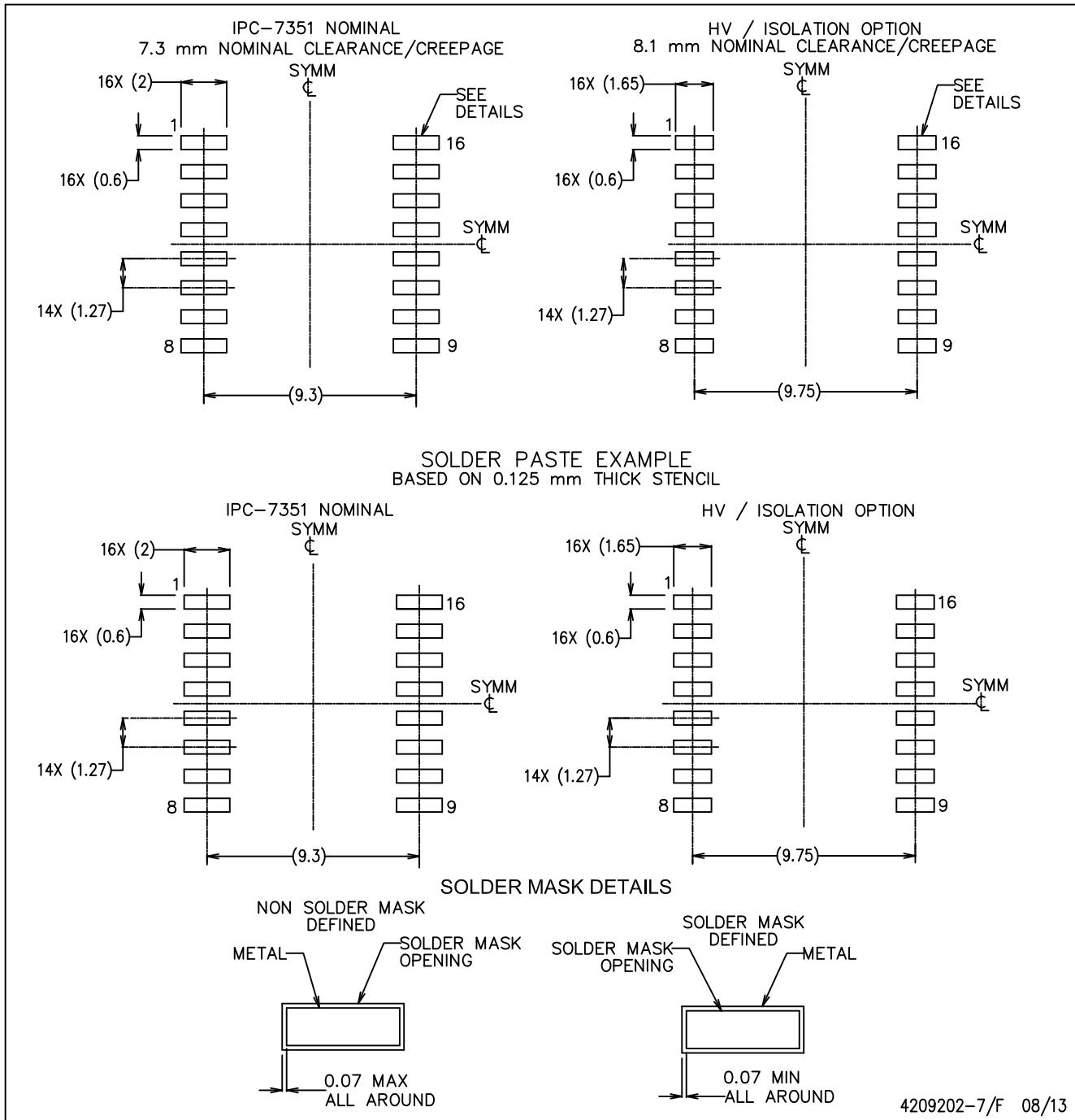

4209202-7/F 08/13

- NOTES:
- A. All linear dimensions are in millimeters.
 - B. This drawing is subject to change without notice.
 - C. Refer to IPC7351 for alternate board design.
 - D. Solder mask tolerances between and around signal pads can vary based on board fabrication site.
 - E. Laser cutting apertures with trapezoidal walls and rounded corners may offer better paste release. IPC-7525 may have alternate design recommendations.
 - F. Board assembly site may have different recommendations for stencil design.

IMPORTANT NOTICE

Texas Instruments Incorporated and its subsidiaries (TI) reserve the right to make corrections, enhancements, improvements and other changes to its semiconductor products and services per JESD46, latest issue, and to discontinue any product or service per JESD48, latest issue. Buyers should obtain the latest relevant information before placing orders and should verify that such information is current and complete. All semiconductor products (also referred to herein as "components") are sold subject to TI's terms and conditions of sale supplied at the time of order acknowledgment.

TI warrants performance of its components to the specifications applicable at the time of sale, in accordance with the warranty in TI's terms and conditions of sale of semiconductor products. Testing and other quality control techniques are used to the extent TI deems necessary to support this warranty. Except where mandated by applicable law, testing of all parameters of each component is not necessarily performed.

TI assumes no liability for applications assistance or the design of Buyers' products. Buyers are responsible for their products and applications using TI components. To minimize the risks associated with Buyers' products and applications, Buyers should provide adequate design and operating safeguards.

TI does not warrant or represent that any license, either express or implied, is granted under any patent right, copyright, mask work right, or other intellectual property right relating to any combination, machine, or process in which TI components or services are used. Information published by TI regarding third-party products or services does not constitute a license to use such products or services or a warranty or endorsement thereof. Use of such information may require a license from a third party under the patents or other intellectual property of the third party, or a license from TI under the patents or other intellectual property of TI.

Reproduction of significant portions of TI information in TI data books or data sheets is permissible only if reproduction is without alteration and is accompanied by all associated warranties, conditions, limitations, and notices. TI is not responsible or liable for such altered documentation. Information of third parties may be subject to additional restrictions.

Resale of TI components or services with statements different from or beyond the parameters stated by TI for that component or service voids all express and any implied warranties for the associated TI component or service and is an unfair and deceptive business practice. TI is not responsible or liable for any such statements.

Buyer acknowledges and agrees that it is solely responsible for compliance with all legal, regulatory and safety-related requirements concerning its products, and any use of TI components in its applications, notwithstanding any applications-related information or support that may be provided by TI. Buyer represents and agrees that it has all the necessary expertise to create and implement safeguards which anticipate dangerous consequences of failures, monitor failures and their consequences, lessen the likelihood of failures that might cause harm and take appropriate remedial actions. Buyer will fully indemnify TI and its representatives against any damages arising out of the use of any TI components in safety-critical applications.

In some cases, TI components may be promoted specifically to facilitate safety-related applications. With such components, TI's goal is to help enable customers to design and create their own end-product solutions that meet applicable functional safety standards and requirements. Nonetheless, such components are subject to these terms.

No TI components are authorized for use in FDA Class III (or similar life-critical medical equipment) unless authorized officers of the parties have executed a special agreement specifically governing such use.

Only those TI components which TI has specifically designated as military grade or "enhanced plastic" are designed and intended for use in military/aerospace applications or environments. Buyer acknowledges and agrees that any military or aerospace use of TI components which have **not** been so designated is solely at the Buyer's risk, and that Buyer is solely responsible for compliance with all legal and regulatory requirements in connection with such use.

TI has specifically designated certain components as meeting ISO/TS16949 requirements, mainly for automotive use. In any case of use of non-designated products, TI will not be responsible for any failure to meet ISO/TS16949.

Products

Audio	www.ti.com/audio
Amplifiers	amplifier.ti.com
Data Converters	dataconverter.ti.com
DLP® Products	www.dlp.com
DSP	dsp.ti.com
Clocks and Timers	www.ti.com/clocks
Interface	interface.ti.com
Logic	logic.ti.com
Power Mgmt	power.ti.com
Microcontrollers	microcontroller.ti.com
RFID	www.ti-rfid.com
OMAP Applications Processors	www.ti.com/omap
Wireless Connectivity	www.ti.com/wirelessconnectivity

Applications

Automotive and Transportation	www.ti.com/automotive
Communications and Telecom	www.ti.com/communications
Computers and Peripherals	www.ti.com/computers
Consumer Electronics	www.ti.com/consumer-apps
Energy and Lighting	www.ti.com/energy
Industrial	www.ti.com/industrial
Medical	www.ti.com/medical
Security	www.ti.com/security
Space, Avionics and Defense	www.ti.com/space-avionics-defense
Video and Imaging	www.ti.com/video

TI E2E Community

e2e.ti.com