



Product Overview

LB11867FV: Variable Speed Single-Phase Full-Wave Pre-Driver

For complete documentation, see the data sheet

Product Description

LB11867FV is a single-phase bipolar driving motor pre-driver with the variable speed function compatible with external PWM signal. With a few external parts, a highly-efficient and highly-silent variable drive fan motor with low power consumption can be achieved. This product is best suited for driving of the server requiring large air flow and large current and the fan motor of consumer appliances.

Features

- Single-phase full-wave driving pre-driver
- Variable speed control possible with external PWM input
- Current limiting circuit incorporated
- Reactive current cut circuit incorporated
- Minimum speed setting pin
- Soft start setting pin
- Lock protection and automatic reset circuits incorporated
- FG (rotation speed detection) output
- Thermal shutdown circuit incorporated

Benefits

- Low-saturation drive using external PMOS-NMOS enables high-efficiency low power-consumption drive
- Separately-excited upper direct PWM (f =30kHz) control method ensures highly silent speed control
- Chopper type current limiting made at startup and during lock
- Reactive current before phase changeover is cut, ensuring highly silent and low power-consumption drive
- Minimum speed setting
- Soft start setting
- Lock protection
- Easy Speed control
- Thermal protection

Applications

- Computing & Peripherals
- Industrial

End Products

- Server
- Vending Machine

Part Electrical Specifications

Product	Compliance	Status	Phase	V _M Min (V)	V _M Max (V)	V _{CC} Min (V)	V _{CC} Max (V)	I _O Max (A)	I _O Peak Max (A)	Control Type	Current Sense	Regulator Output	Fault Detection	R _{DS(on)} Typ (Ω)	Package Type
LB11867FV-TLM-H	Pb-free Halide free	Active	1			5.5	16	0.02		PWM	External Resistor	Yes	Over-Current		SSOP-16

Application Diagram

Application Circuit Example (12V)

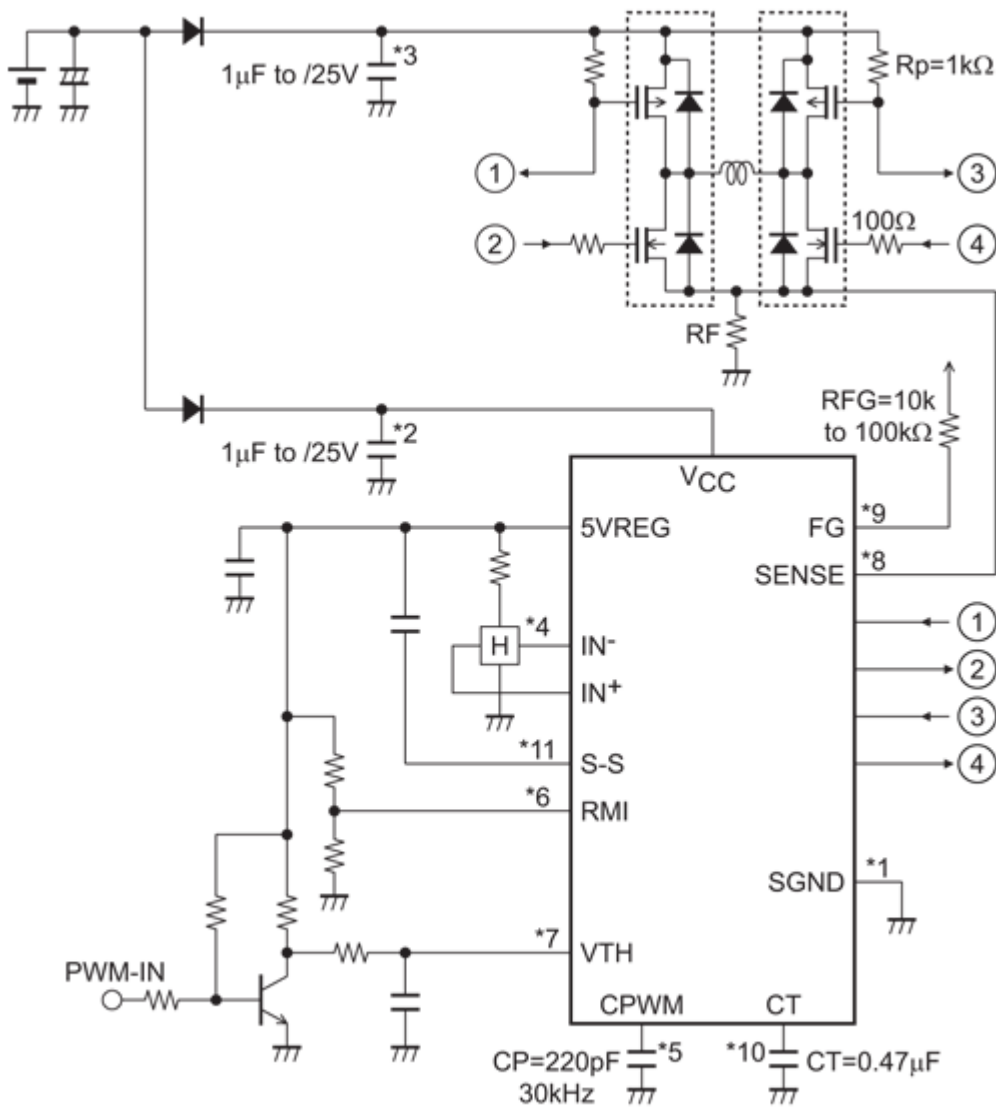

Note *1 to *11 information, please identify a datasheet.

For more information please contact your local sales support at www.onsemi.com

Created on: 12/20/2015