

7/8" (22.2 mm) Precision Industrial Potentiometer, Bushing And Servo Mount Versions, Conductive Plastic

FEATURES

- High quality
- Rugged one piece metal housing
- Long rotational life
- Wide operating temperature range
- Linearities down to ± 0.25 % special
- Optional sealed construction (bushing mount only)
- Material categorization: for definitions of compliance please see www.vishay.com/doc?99912

RoHS
COMPLIANT

QUICK REFERENCE DATA

Sensor type	ROTATIONAL, conductive plastic
Output type	Output by turrets
Market appliance	Industrial
Dimensions	7/8" (22.2 mm)

ELECTRICAL SPECIFICATIONS

PARAMETER	MIL-PRF-39023 TEST PROCEDURES APPLY
Resistance	1 k Ω to 100 k Ω
Resistance Tolerance	± 20 %
Special to	± 10 %
Linearity	± 2.0 %
Special to	± 0.25 %
Temperature Coefficient of Resistance	± 600 ppm/ $^{\circ}$ C
Power Rating	1.0 W at 40 $^{\circ}$ C ambient
Derated to	0 W at 125 $^{\circ}$ C
Electrical Angle	340 $^{\circ}$ \pm 4 $^{\circ}$
End Voltage	0.5 % maximum
Dielectric Withstanding	1000 V _{RMS} , 60 Hz
Insulation Resistance	100 M Ω minimum, 500 V _{DC}
Output Smoothness	0.1 %

MECHANICAL SPECIFICATIONS

PARAMETER		
Weight	0.5 oz. maximum (14 g)	
Rotation	360 $^{\circ}$ (continuous)	
Mount	BUSHING	SERVO
Bearing Type	Sleeve bearing	Ball bearing
Operating Torque		
Starting	0.30 oz. - in (21.6 g - cm)	0.25 oz. - in (18 g - cm)
Running	0.25 oz. - in (18 g - cm)	0.15 oz. - in (10.8 g - cm)
Mechanical Tolerance (in/mm) (maximum)		
Shaft Runout (TIR)	0.002" (0.05 mm)	0.002" (0.05 mm)
Pilot Dia Runout (TIR)	-	0.002" (0.05 mm)
Lateral Runout (TIR)	0.005" (0.13 mm)	0.002" (0.05 mm)
Shaft End Play	0.006" (0.15 mm)	0.005" (0.13 mm)
Shaft Radial Play	0.003" (0.08 mm)	0.002" (0.05 mm)

ORDERING INFORMATION										
1	5	7	B	5	0	3	M	C		
MODEL	STYLE		OHMIC VALUE			TOLERANCE ON OHMIC VALUE		LINEARITY		SPECIAL REQUEST
157	B: Bushing S: servo		470 = 47 Ω 222 = 2.200 Ω 103 = 10 kΩ For ohmic value range see electrical specification			M = ± 20 % K = ± 10 %		X = ± 2 % B = ± 0.50 % C = ± 0.25 %		xxxx

PART NUMBER DESCRIPTION (for information only)			
157-	2	503	xxxx
MODEL	STYLE	OHMIC VALUE	SPECIAL
	B: 1 S: 2		

DIMENSIONS in inches (millimeters)

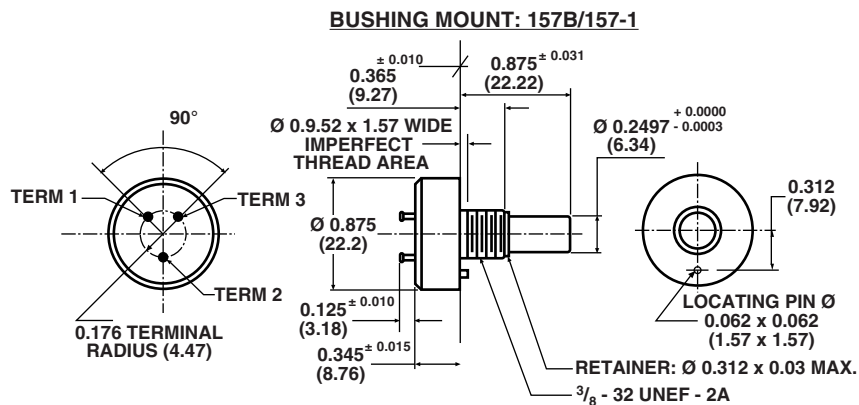

Example of a marking for a standard part:
157-11103

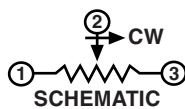

TOLERANCES: UNLESS OTHERWISE NOTED.
DECIMALS ± 0.005 ANGLES ± 2°

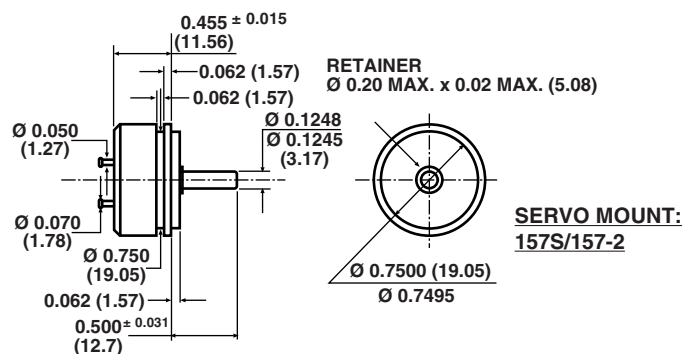



MATERIAL SPECIFICATIONS	
Housing/Bushing	Aluminum, anodized
Rear Lid	Ceramic
Shaft	Stainless steel
Terminals	Solderable
Bushing Mount Hardware	Lockwasher, internal tooth steel, nickel plated
Panel Nut	Brass, nickel plated

ENVIRONMENTAL SPECIFICATIONS					
Temperature	-55 °C to +125 °C				
Rotational Life	<table border="1"> <thead> <tr> <th>BUSHING</th> <th>SERVO</th> </tr> </thead> <tbody> <tr> <td>5 million shaft revolutions</td> <td>10 million shaft revolutions</td> </tr> </tbody> </table>	BUSHING	SERVO	5 million shaft revolutions	10 million shaft revolutions
BUSHING	SERVO				
5 million shaft revolutions	10 million shaft revolutions				
Moisture Resistant	Yes				
Vibration	15 g 10 to 2000 Hz				
Shock	50 g				
Salt Spray	96 h				
Load Life	900 h				

Note

- Nothing stated herein shall be construed as a guarantee of quality or durability.



Disclaimer

ALL PRODUCT, PRODUCT SPECIFICATIONS AND DATA ARE SUBJECT TO CHANGE WITHOUT NOTICE TO IMPROVE RELIABILITY, FUNCTION OR DESIGN OR OTHERWISE.

Vishay Intertechnology, Inc., its affiliates, agents, and employees, and all persons acting on its or their behalf (collectively, "Vishay"), disclaim any and all liability for any errors, inaccuracies or incompleteness contained in any datasheet or in any other disclosure relating to any product.

Vishay makes no warranty, representation or guarantee regarding the suitability of the products for any particular purpose or the continuing production of any product. To the maximum extent permitted by applicable law, Vishay disclaims (i) any and all liability arising out of the application or use of any product, (ii) any and all liability, including without limitation special, consequential or incidental damages, and (iii) any and all implied warranties, including warranties of fitness for particular purpose, non-infringement and merchantability.

Statements regarding the suitability of products for certain types of applications are based on Vishay's knowledge of typical requirements that are often placed on Vishay products in generic applications. Such statements are not binding statements about the suitability of products for a particular application. It is the customer's responsibility to validate that a particular product with the properties described in the product specification is suitable for use in a particular application. Parameters provided in datasheets and/or specifications may vary in different applications and performance may vary over time. All operating parameters, including typical parameters, must be validated for each customer application by the customer's technical experts. Product specifications do not expand or otherwise modify Vishay's terms and conditions of purchase, including but not limited to the warranty expressed therein.

Except as expressly indicated in writing, Vishay products are not designed for use in medical, life-saving, or life-sustaining applications or for any other application in which the failure of the Vishay product could result in personal injury or death. Customers using or selling Vishay products not expressly indicated for use in such applications do so at their own risk. Please contact authorized Vishay personnel to obtain written terms and conditions regarding products designed for such applications.

No license, express or implied, by estoppel or otherwise, to any intellectual property rights is granted by this document or by any conduct of Vishay. Product names and markings noted herein may be trademarks of their respective owners.

Material Category Policy

Vishay Intertechnology, Inc. hereby certifies that all its products that are identified as RoHS-Compliant fulfill the definitions and restrictions defined under Directive 2011/65/EU of The European Parliament and of the Council of June 8, 2011 on the restriction of the use of certain hazardous substances in electrical and electronic equipment (EEE) - recast, unless otherwise specified as non-compliant.

Please note that some Vishay documentation may still make reference to RoHS Directive 2002/95/EC. We confirm that all the products identified as being compliant to Directive 2002/95/EC conform to Directive 2011/65/EU.

Vishay Intertechnology, Inc. hereby certifies that all its products that are identified as Halogen-Free follow Halogen-Free requirements as per JEDEC JS709A standards. Please note that some Vishay documentation may still make reference to the IEC 61249-2-21 definition. We confirm that all the products identified as being compliant to IEC 61249-2-21 conform to JEDEC JS709A standards.