

THIS DRAWING IS UNPUBLISHED. RELEASED FOR PUBLICATION  
 © COPYRIGHT - By - ALL RIGHTS RESERVED.

LOC	DIST	REVISIONS					
HB	-	P	LTR	DESCRIPTION	DATE	DWN	APVD
		G		REMOVED THE RIB ON THE BASE TO CASE ECO-15-011310	04DEC2015	HYS	CHL

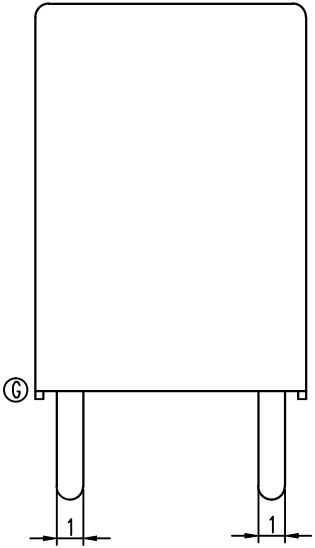
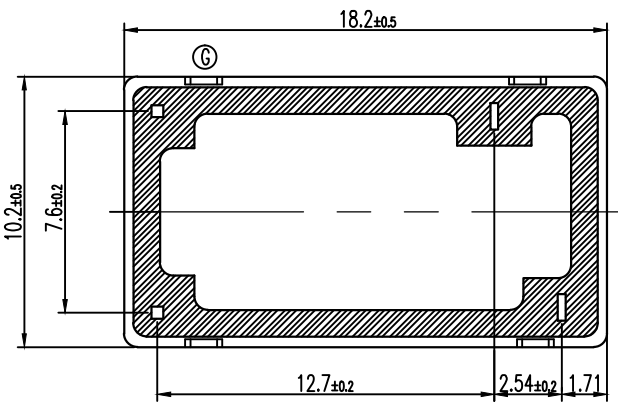
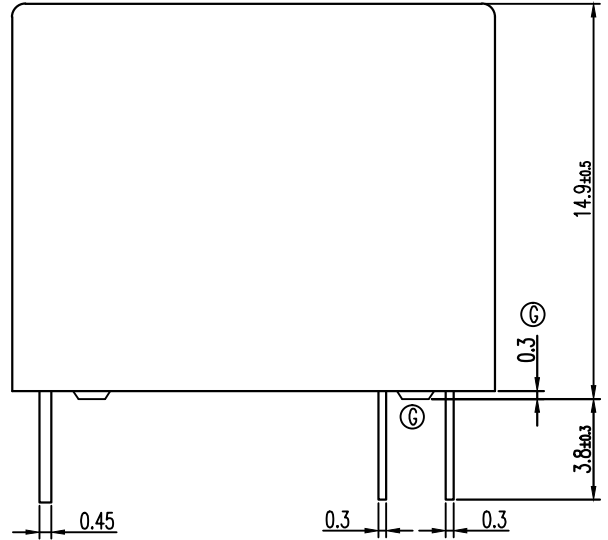
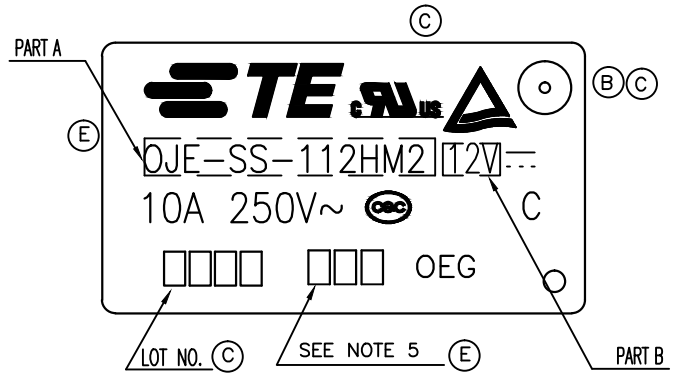
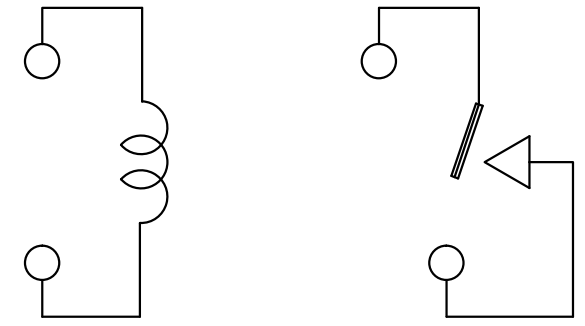

Diagram dimension	Tolerance
0.99mm max.	±0.1mm
1 - 2.99mm	±0.2mm
3mm min.	±0.3mm



CONNECTION FIGURE

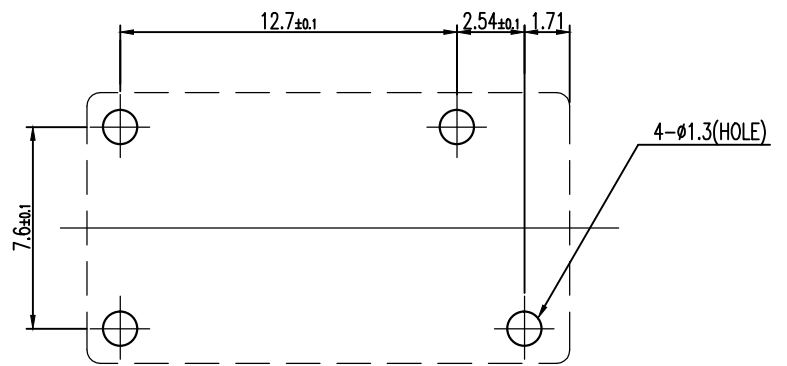

FIGURE FOR PRINTED CIRCUIT BOARD PROCESSING (BOTTOM VIEW)

THIS DRAWING IS A CONTROLLED DOCUMENT.		DWN	GR.ZHOU	-
DIMENSIONS: mm		CHK	XN.ZHANG	-
TOLERANCES UNLESS OTHERWISE SPECIFIED:		APVD	C.H.HSU	-
0 PLC ± -		PRODUCT SPEC	NAME	
1 PLC ± -		APPLICATION SPEC	OJE-HM2 Cd FREE CUSTOMER DRAWING	
2 PLC ± -		WEIGHT	SIZE	CAGE CODE
3 PLC ± -		-	A3	00779
4 PLC ± -		CUSTOMER DRAWING	DRAWING NO	1721539
ANGLES ± -		SCALE	5:1	SHEET 1 OF 2
MATERIAL	FINISH	RESTRICTED TO	REV G	
-	-	-		

THIS DRAWING IS UNPUBLISHED. RELEASED FOR PUBLICATION - , - .  
 © COPYRIGHT - By - ALL RIGHTS RESERVED.

LOC	DIST	REVISIONS					
HB	-	P	LTR	DESCRIPTION	DATE	DWN	APVD
		-		SEE SHEET 1	-	-	-

1-1721539-6	OJE-SH-148HM2	48V	OJE-SH-148HM2	P
1-1721539-5	OJE-SH-124HM2	24V	OJE-SH-124HM2	O
1-1721539-4	OJE-SH-118HM2	18V	OJE-SH-118HM2	N
1-1721539-3	OJE-SH-112HM2	12V	OJE-SH-112HM2	M
1-1721539-2	OJE-SH-109HM2	9V	OJE-SH-109HM2	L
1-1721539-1	OJE-SH-106HM2	6V	OJE-SH-106HM2	K
1-1721539-0	OJE-SH-105HM2	5V	OJE-SH-105HM2	J
1721539-9	OJE-SH-103HM2	3V	OJE-SH-103HM2	I
1721539-8	OJE-SS-148HM2	48V	OJE-SS-148HM2	H
1721539-7	OJE-SS-124HM2	24V	OJE-SS-124HM2	G
1721539-6	OJE-SS-118HM2	18V	OJE-SS-118HM2	F
1721539-5	OJE-SS-112HM2	12V	OJE-SS-112HM2	E
1721538-4	OJE-SS-109HM2	9V	OJE-SS-109HM2	D
1721539-3	OJE-SS-106HM2	6V	OJE-SS-106HM2	C
1721539-2	OJE-SS-105HM2	5V	OJE-SS-105HM2	B
1721539-1	OJE-SS-103HM2	3V	OJE-SS-103HM2	A
TE PART NO	DESCRIPTION	PART B	PART A	TYPE

RELAY TYPE

NOTES:  
 1.TERMINAL DIMENSION BEFORE TINNING.  
 2.LOT NO. SYSTEM AS FOLLOWING:

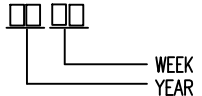

- Ⓔ 2.TERMINAL DIMENSION IS BEFORE SOLDER DIP;
- Ⓔ 3.FOR THE TIN-PLATING OF THE PINS:  
+0.1mm FOR WIDTH,THICKENSS AND DIAMETER.  
+0.5mm FOR LENGTH.

- Ⓔ 5.ADD LOT NO. SYSTEM AS FOLLOWING;  
 I, DIGITS FOR DAY OF THE WEEK  
 1...MONDAY IN THIS WEEK;  
 2...TUESDAY IN THIS WEEK;  
 .....  
 7...SUNDAY IN THIS WEEK  
 II, DIGITS FOR SHIFT OF THE DAY  
 1...DAY SHIFT IN THIS DAY;  
 2...NIGHT SHIFT IN THIS DAY;  
 III, ONE CHARACTER DISTINGUISH THE LINE IDENTITY, SUCH AS: A,B,....Z



		UV RESIN	UV SEAL	16
		EPOXY RESIN	SEEL (BASE & BOBBIN)	15
		JUEW	MAGNETIC WIRE	14
94V-0		P.B.T	CASE (BLUE)	13
94V-0		P.B.T	BASE	12
94V-0		P.B.T	BOBBIN	11
	SOLDER DIP	C.P WIRE	COIL TERMINAL	10
94V-0		P.P.S	CARD	9
		Ag ALLOY	MOVABLE CONTACT	8
		Ag ALLOY	NO.CONTACT	7
		STEEL	HINGE SPRING	6
	SOLDER DIP	PBP	NO.TERMINAL	5
	SOLDER DIP	Cu ALLOY	MOVABLE SPRING	4
	NIP	STEEL	CORE	3
	NIP	STEEL	ARMATURE	2
	NIP	STEEL	YOKE	1
INCOMBUSTIBILITY	TREATMENT	MATERIAL	DESCRIPTION	ITEM

ⒺⒺ 4.MARKING FROM INK TO LASER AND USING WELDED CONTACT

THIS DRAWING IS A CONTROLLED DOCUMENT.		DWN	GR.ZHOU	-												
DIMENSIONS: mm		CHK	XN.ZHANG	-												
TOLERANCES UNLESS OTHERWISE SPECIFIED:		APVD	C.H.HSU	-												
<table border="1"> <tr><td>0 PLC</td><td>± -</td></tr> <tr><td>1 PLC</td><td>± -</td></tr> <tr><td>2 PLC</td><td>± -</td></tr> <tr><td>3 PLC</td><td>± -</td></tr> <tr><td>4 PLC</td><td>± -</td></tr> <tr><td>ANGLES</td><td>± -</td></tr> </table>		0 PLC	± -	1 PLC	± -	2 PLC	± -	3 PLC	± -	4 PLC	± -	ANGLES	± -	PRODUCT SPEC	NAME	
0 PLC	± -															
1 PLC	± -															
2 PLC	± -															
3 PLC	± -															
4 PLC	± -															
ANGLES	± -															
MATERIAL		APPLICATION SPEC	OJE-HM2 Cd FREE CUSTOMER DRAWING													
FINISH		WEIGHT	SIZE	RESTRICTED TO												
			A3													
		CUSTOMER DRAWING	CAGE CODE	DRAWING NO												
			00779	1721539												
		SCALE	SHEET	REV												
		5:1	2 OF 2	G												