

P.C. BOARD MOUNTING

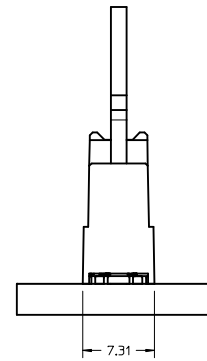
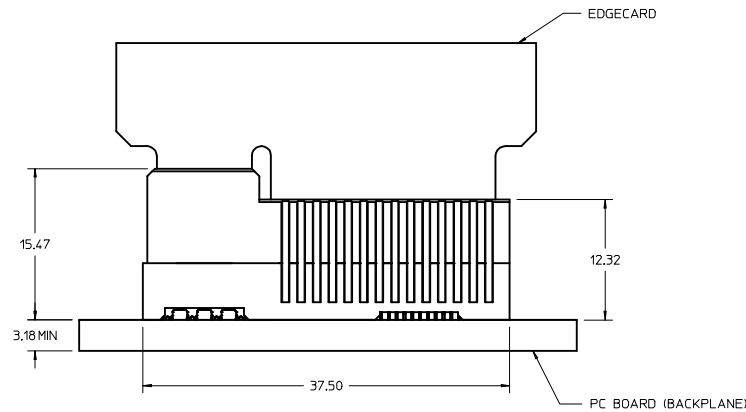
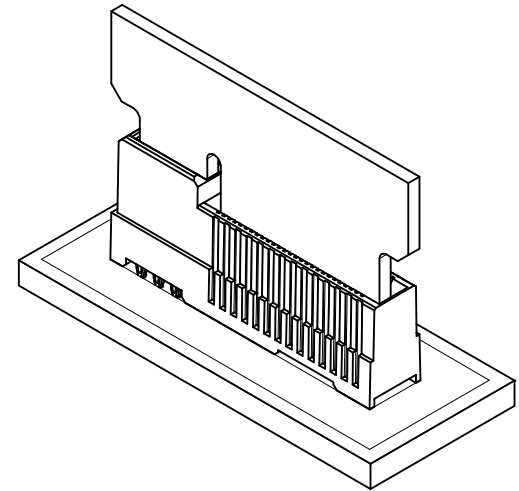
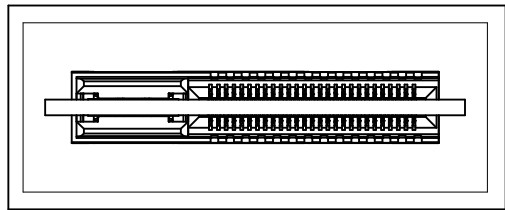

NOTES:

1. MATERIAL:
HOUSING - GLASS FILLED THERMOPLASTIC, 94-V0, BLACK
TERMINALS - COPPER ALLOY
2. FINISH:
CONTACT AREA: HARD GOLD -0.76μm MIN OVER 3.80μ NICKEL
COMPLIANT AREA: TIN - 0.76/1524μ OVER NICKEL
3. REFER TO PS-76861-100 PRODUCT SPECIFICATION FOR ALL ELECTRICAL, MECHANICAL AND ENVIRONMENTAL SPECIFICATIONS.
4. REFER TO PK-76861-900 FOR ALL PACKAGING SPECIFICATIONS.
5. APPLICATION SPECIFICATION: AS-76693-100.
6. THIS PART CONFORMS TO CLASS B REQUIREMENTS OF COSMETIC SPEC PS-45499-002

EDGECARD SPEC UPDATED EC NO: UCP2015-1286 DRWNGS 2014/09/29 CHYK:MPFF 2014/10/13 APPRS:SMILLER 2015/01/29	QUALITY SYMBOLS	GENERAL TOLERANCES (UNLESS SPECIFIED)	DIMENSION STYLE	SCALE	DESIGN UNITS	THIRD ANGLE PROJECTION	
	▽=0	4 PLACES ± --- + ---	MM ONLY	4:1	METRIC	☑	
	▽=0	3 PLACES ± --- + ---	DRAWN BY DATE	TITLE			
	▽=0	2 PLACES ±0.13 + ---	MPOFF 2014/05/20	ESP 12.5GB			
	1 PLACE ±0.25 + ---	CHECKED BY DATE	0.062"PCB/0.8MM PITCH				
	0 PLACE ± --- + ---	DMORGAN 2014/05/20	54 CKTS				
	ANGULAR ± 2 °	APPROVED BY DATE	molex				
	DRAFT WHERE APPLICABLE MUST REMAIN WITHIN DIMENSIONS	SMILLER 2014/07/23	MATERIAL NO.	DOCUMENT NO.	SHEET NO.		
			76861-1130	SD-76861-1130	1 OF 4		
			THIS DRAWING CONTAINS INFORMATION THAT IS PROPRIETARY TO MOLEX INCORPORATED AND SHOULD NOT BE USED WITHOUT WRITTEN PERMISSION				

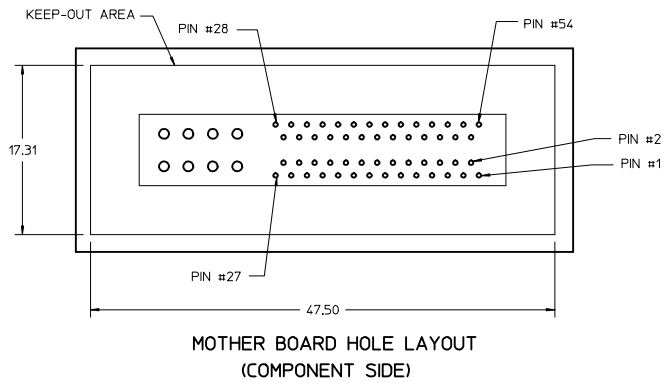
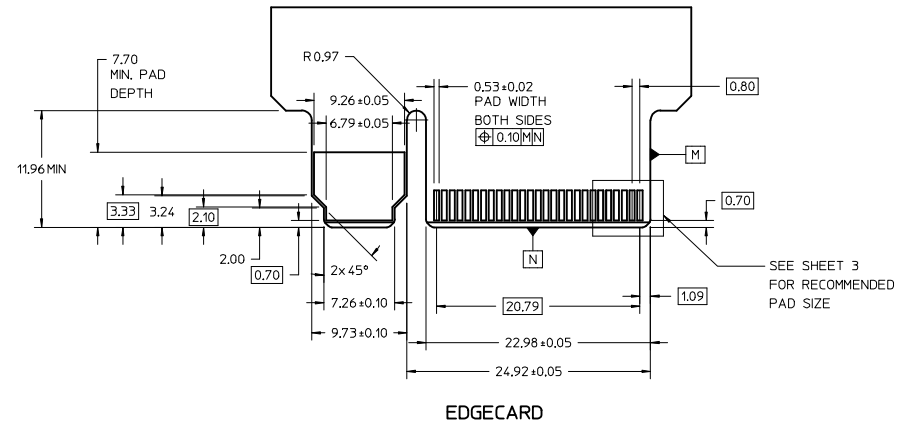
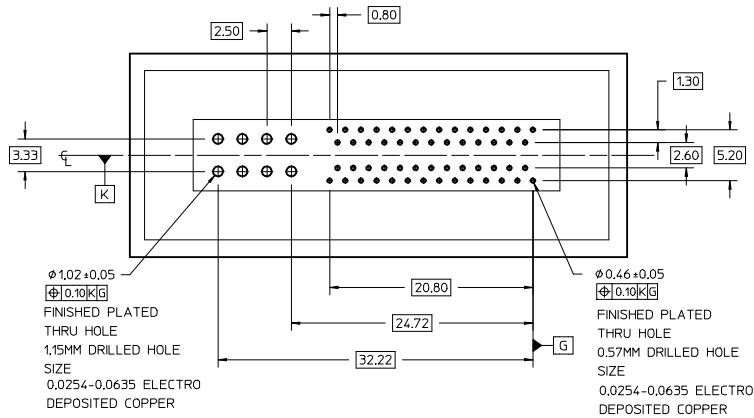

SEE SHEET 1 EC NO: UCP2015-1286 2014/09/29 CHKO: MPOFF 2014/10/13 APPR: SMILLER 2015/01/29	QUALITY SYMBOLS $\nabla=0$ $\nabla=0$ $\nabla=0$	GENERAL TOLERANCES (UNLESS SPECIFIED) mm INCH		DIMENSION STYLE MM ONLY	SCALE 4:1	DESIGN UNITS METRIC	THIRD ANGLE PROJECTION	
		4 PLACES ± --- ± --- 3 PLACES ± --- ± --- 2 PLACES ± 0.13 ± --- 1 PLACE ± 0.25 ± --- 0 PLACE ± --- ± ---	ANGLUAR ± 2 ° DRAFT WHERE APPLICABLE MUST REMAIN WITHIN DIMENSIONS	DRAWN BY MPOFF DATE 2014/05/120	CHECKED BY DMORGAN DATE 2014/05/120	APPROVED BY SMILLER DATE 2014/07/123	TITLE ESP 12.5GB 0.062"PCB/0.8MM PITCH 54 CKTS	MATERIAL NO. SD-76861-1130

LEGEND EDGELINE 54 CIRCUITS / 0.062"PCB									
COMPONENT SIDE 1					COMPONENT SIDE 2				
PIN NO.	SIGNAL	ALLEGRO PIN NO.				SIGNAL	PIN NO.		
54	GND	○			○	SIGNAL 1	1		
53	SATA0_TX_P	○	○		○	SIGNAL 2	2		
52	SATA0_TX_N	○			○	SIGNAL 3	3		
51	GND	○	○		○	SIGNAL 4	4		
50	SATA0_RX_N	○			○	SIGNAL 5	5		
49	SATA0_RX_P	○	○		○	SIGNAL 6	6		
48	GND	○			○	PSV_STBY1	7		
47	SATA1_TX_P	○	○		○	SIGNAL 7	8		
46	SATA1_TX_N	○			○	SIGNAL 8	9		
45	GND	○	○		○	SIGNAL 9	10		
44	SATA1_RX_N	○			○	SIGNAL 10	11		
43	SATA1_RX_P	○	○		○	SIGNAL 11	12		
42	GND	○			○	SIGNAL 12	13		
41	SATA2_TX_P	○	○		○	SIGNAL 13	14		
40	SATA2_TX_N	○			○	SIGNAL 14	15		
39	GND	○	○		○	PSV_STBY2	16		
38	SATA2_RX_N	○			○	SIGNAL 15	17		
37	SATA2_RX_P	○	○		○	SIGNAL 16	18		
36	GND	○	○		○	GND	19		
35	SATA3_TX_P	○	○		○	SATA3_RX_P	20		
34	SATA3_TX_N	○			○	SATA3_RX_N	21		
33	GND	○	○		○	GND	22		
32	RESERVE	○			○	RESERVE	23		
31	TBD	○	○		○	TBD	24		
30	TBD	○			○	TBD	25		
29	TBD	○	○		○	TBD	26		
28	TBD	○			○	TBD	27		
POWER	LPH POWER, 2 CIRCUIT						RETURN		

SEE SHEET 1 IEC NO: UICP2015-1286 2014/09/29 CHYKOMP OFF 2014/10/13 APPR:SMILLER 2015/01/29	QUALITY SYMBOLS ▽=0 ▽=0 ▽=0	GENERAL TOLERANCES (UNLESS SPECIFIED) mm INCH		DIMENSION STYLE MM ONLY	SCALE 4:1	DESIGN UNITS METRIC	THIRD ANGLE PROJECTION
		4 PLACES ±0.13 ±0.005 3 PLACES ±0.25 ±0.010 2 PLACES ±0.50 ±0.020 1 PLACE ±1.00 ±0.050 0 PLACE ±2.00 ±0.100	DRAWN BY MPOFF	DATE 2014/05/20	TITLE ESP 12.5GB 0.062"PCB/0.8MM PITCH 54 CKTS		
		ANGULAR ± 2 ° DRAFT WHERE APPLICABLE MUST REMAIN WITHIN DIMENSIONS	APPROVED BY SMILLER	DATE 2014/07/23	molex		
		MATERIAL NO. SEE SHEET 1	DOCUMENT NO. SD-76861-1130	SHEET NO. 4 OF 4			

P.C. BOARD MOUNTING

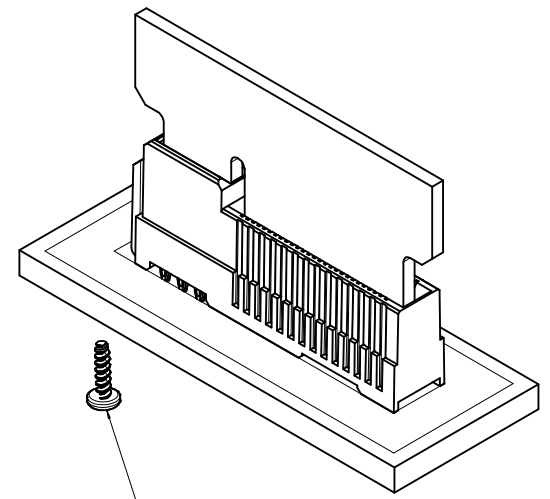
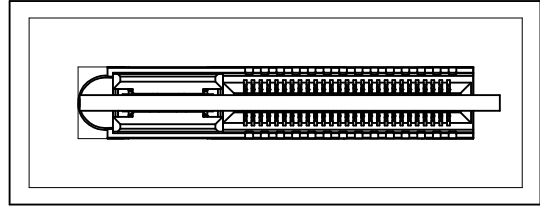

RECOMMENDED THREAD-FORMING SCREW
M1.8x8 (NOT SUPPLIED BY MOLEX)
SEE NOTE 8

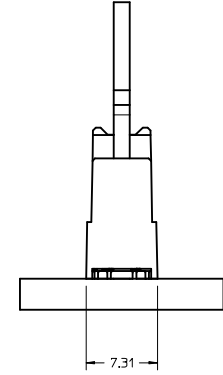
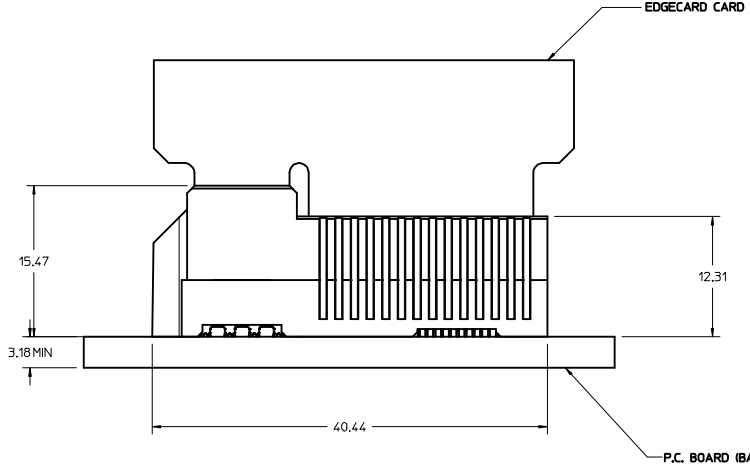

- NOTES:
- MATERIAL:
HOUSING - GLASS FILLED THERMOPLASTIC, 94-V0, BLACK
TERMINALS - COPPER ALLOY
 - FINISH:
CONTACT AREA: HARD GOLD -0.76µm MIN OVER 3.80µ NICKEL
COMPLIANT AREA: TIN - 0.76/1.52µm OVER NICKEL
 - REFER TO PS-76861-100 PRODUCT SPECIFICATION FOR ALL ELECTRICAL, MECHANICAL AND ENVIRONMENTAL SPECIFICATIONS.
 - REFER TO PK-76861-900 FOR ALL PACKAGING SPECIFICATIONS.
 - PROCESSING: PRESSFIT TO PC BOARD.
 - MATING PC BOARD THICKNESS = 1.60±0.16MM OVER CONTACT PADS.
 - THIS PART CONFORMS TO CLASS B REQUIREMENTS OF COSMETIC SPEC PS-45499-002
 - REFER TO APPLICATION SPECIFICATION AS-76693-100 FOR MORE DETAILS

UPDATE NOTE 8 ELEC NO: UCP2015-4515 DRAWN BY: DORWINHOFF CHECKED BY: CHYKIDMORGAN APPROVED BY: APPRSMILLER DATE: 2015/05/05 DATE: 2015/05/05 DATE: 2015/06/08	QUALITY SYMBOLS	GENERAL TOLERANCES (UNLESS SPECIFIED)	DIMENSION STYLE	SCALE	DESIGN UNITS	THIRD ANGLE PROJECTION
	▽=0	4 PLACES ± mm ± INCH	MM ONLY	4:1	METRIC	☑
	▽=0	3 PLACES ± 0.13 ± 0.005				
	▽=0	2 PLACES ± 0.25 ± 0.010				
		ANGULAR ± 2°	DRAWN BY: DROSCA	DATE: 8/11/09	TITLE: ESP 12.5GB 0.062"PCB/0.8MM PITCH 54 CKTS	
		DRAFT WHERE APPLICABLE MUST REMAIN WITHIN DIMENSIONS	CHECKED BY: JCOMERCI	DATE: 8/11/09		
			APPROVED BY: JCOMERCI	DATE: 8/11/09	MATERIAL NO. 76861-1120	DOCUMENT NO. SD-76861-120
					SIZE: D	THIS DRAWING CONTAINS INFORMATION THAT IS PROPRIETARY TO MOLEX INCORPORATED AND SHOULD NOT BE USED WITHOUT WRITTEN PERMISSION

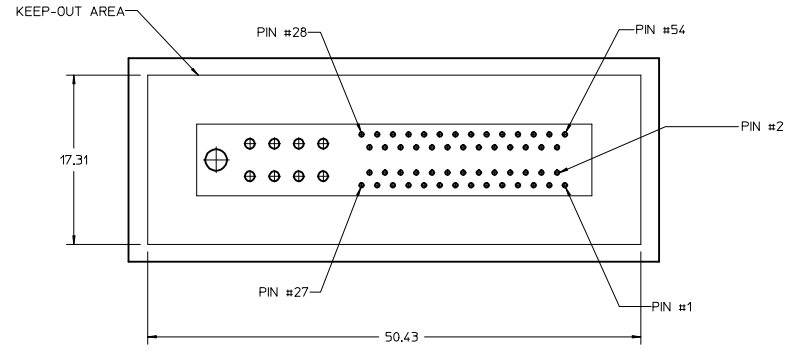
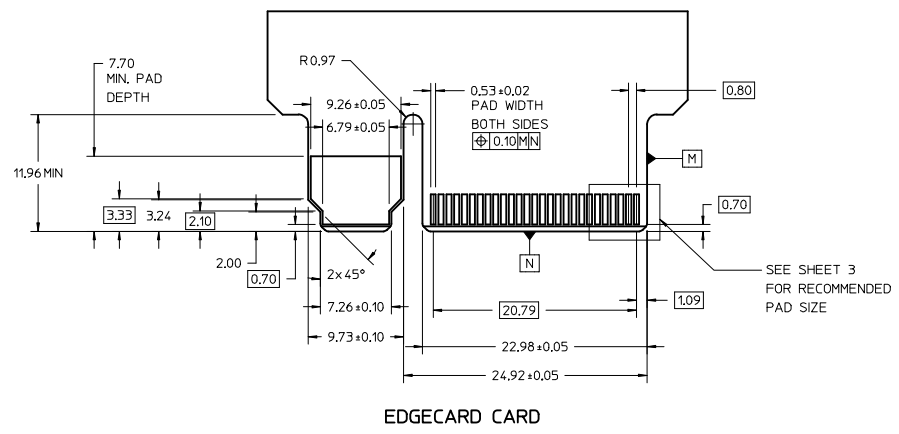
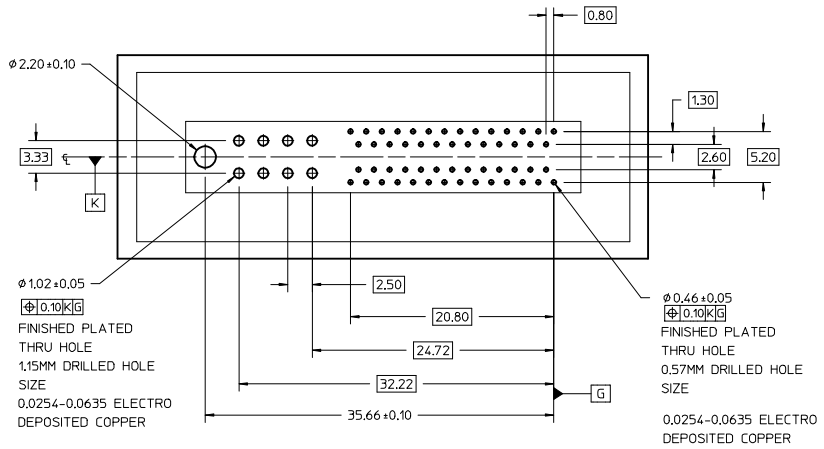

MOTHER BOARD HOLE LAYOUT (COMPONENT SIDE)

SEE SHEET 1 EC NO: UCP2015-4515 DRAWN BY: DRW/MPROFF 2015/05/05 CHKD BY: MORGAN 2015/05/05 APPR: SMILLER 2015/06/08	QUALITY SYMBOLS	GENERAL TOLERANCES (UNLESS SPECIFIED)	DIMENSION STYLE	SCALE	DESIGN UNITS	THIRD ANGLE PROJECTION
	$\nabla=0$ $\nabla=0$ $\nabla=0$	mm INCH 4 PLACES ± --- ± --- 3 PLACES ± 0.13 ± --- 2 PLACES ± 0.25 ± --- 1 PLACE ± --- ± --- 0 PLACE ± --- ± ---	MM ONLY	4:1	METRIC	ESP 12.5GB 0.062"PCB/0.8MM PITCH 54 CKTS molex
	DRAFT WHERE APPLICABLE MUST REMAIN WITHIN DIMENSIONS	DRAWN BY: DROSCA DATE: 8/11/09 CHECKED BY: JCOMERC DATE: 8/11/09 APPROVED BY: JCOMERC DATE: 8/11/09	MATERIAL NO. SEE SHEET 1	DOCUMENT NO. SD-76861-120	SHEET NO. 2 OF 4	
	THIS DRAWING CONTAINS INFORMATION THAT IS PROPRIETARY TO MOLEX INCORPORATED AND SHOULD NOT BE USED WITHOUT WRITTEN PERMISSION					

MODULE EDGE CARD CONTACT DETAIL

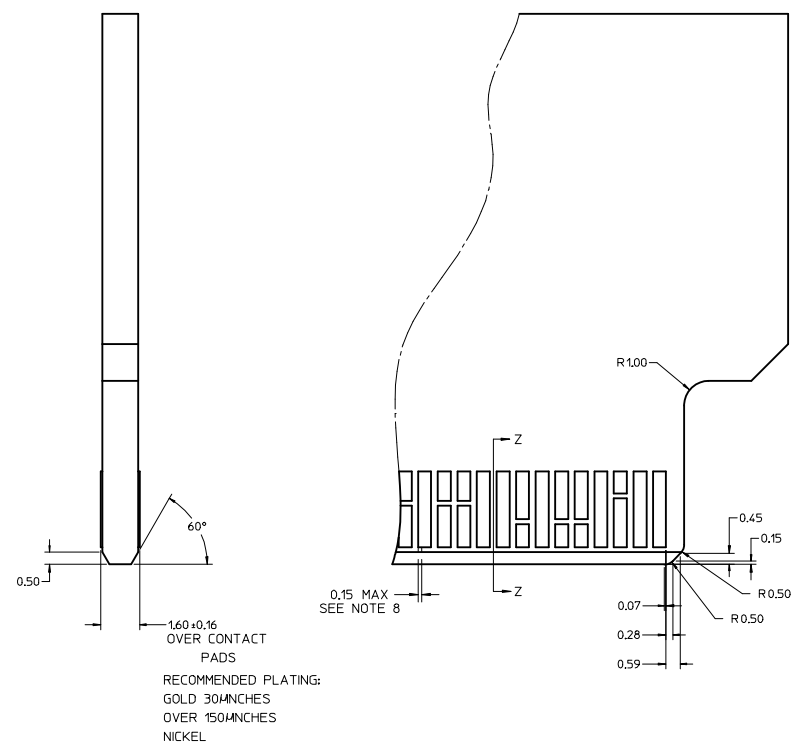
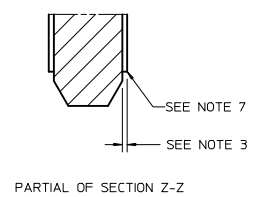
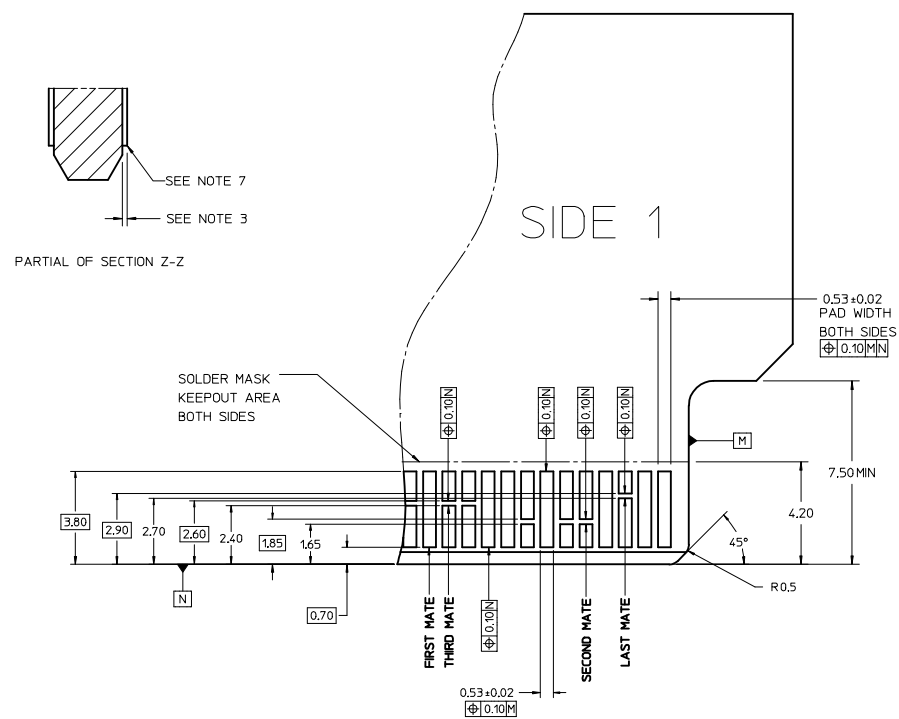

RECOMMENDED PLATING:
GOLD 30MNCHES
OVER 150MNCHES
NICKEL

- MATING PCB NOTES:
- CONNECTOR LAND CONDITIONS SHALL MEET THE MOST CURRENT REVISION OF PCB SPECIFICATION IPC-6012C-2010 SECTION 3.5.4.4.
 - DIMENSIONS APPLY TO LANDS ON BOTH SIDES OF THE BOARD.
 - THE THICKNESS OF THE OUTER METAL LAYERS, INCLUDING FOIL, COPPER PLATING, AND THE PROTECTIVE SURFACE FINISH, SHALL BE 0.066mm MAX.
 - CHAMFER ROUGHNESS NOT TO EXCEED 3.17 MICROMETERS.
 - CHAMFER PROCESS SHALL NOT DAMAGE THE GOLD EDGE LANDS.
 - EDGE CARD CHAMFER NOT TO GO THRU GOLD LANDS.
 - 0.03mm MAX PLATING OVERHANG ON ALL GOLD LAND EDGES.
 - MOLEX RECOMMENDS NO TIE-BARS ON THE LEADING EDGE OF THE GOLD LAND. IF TIE-BARS ARE USED, THEY SHALL BE PLACED TO ONE SIDE OF THE GOLD LAND. APPLIES TO ALL GOLD LANDS.

SEE SHEET 1 EC NO: UCP2015-4515 DRAWN BY: CHYKOR MORGAN CHECKED BY: APPR: SMILLER DATE: 2015/05/05 DATE: 2015/06/08	QUALITY SYMBOLS ∇=0 ∇=0 ∇=0	GENERAL TOLERANCES (UNLESS SPECIFIED)		DIMENSION STYLE MM ONLY	SCALE 10:1	DESIGN UNITS METRIC	THIRD ANGLE PROJECTION
		4 PLACES ± --- ± --- 3 PLACES ± --- ± --- 2 PLACES ± 0.13 ± --- 1 PLACE ± 0.25 ± --- 0 PLACE ± --- ± ---	mm INCH	DRAWN BY: DROSCA DATE: 8/11/09 CHECKED BY: JCOMERCI DATE: 8/11/09 APPROVED BY: JCOMERCI DATE: 8/11/09	TITLE ESP 12.5GB 0.062"PCB/0.8MM PITCH 54 CKTS	MATERIAL NO. SEE SHEET 1	DOCUMENT NO. SD-76861-120

THIS DRAWING CONTAINS INFORMATION THAT IS PROPRIETARY TO MOLEX INCORPORATED AND SHOULD NOT BE USED WITHOUT WRITTEN PERMISSION

LEGEND EDGELINE 54 CIRCUITS / 0.062"PCB						
COMPONENT SIDE 1			COMPONENT SIDE 2			
PIN NO.	SIGNAL	ALLEGRO PIN NO.	SIGNAL	PIN NO.		
54	GND		SIGNAL 1	1		
53	SATA0_TX_P		SIGNAL 2	2		
52	SATA0_TX_N		SIGNAL 3	3		
51	GND		SIGNAL 4	4		
50	SATA0_RX_N		SIGNAL 5	5		
49	SATA0_RX_P		SIGNAL 6	6		
48	GND		PSV_STBY1	7		
47	SATA1_TX_P		SIGNAL 7	8		
46	SATA1_TX_N		SIGNAL 8	9		
45	GND		SIGNAL 9	10		
44	SATA1_RX_N		SIGNAL 10	11		
43	SATA1_RX_P		SIGNAL 11	12		
42	GND		SIGNAL 12	13		
41	SATA2_TX_P		SIGNAL 13	14		
40	SATA2_TX_N		SIGNAL 14	15		
39	GND		PSV_STBY2	16		
38	SATA2_RX_N		SIGNAL 15	17		
37	SATA2_RX_P		SIGNAL 16	18		
36	GND		GND	19		
35	SATA3_TX_P		SATA3_RX_P	20		
34	SATA3_TX_N		SATA3_RX_N	21		
33	GND		GND	22		
32	RESERVE		RESERVE	23		
31	TBD		TBD	24		
30	TBD		TBD	25		
29	TBD		TBD	26		
28	TBD		TBD	27		

POWER	LPH POWER, 2 CIRCUIT	RETURN
-------	----------------------	--------

SEE SHEET 1 IEC NO: UICP2015-4515 DRAWN BY: CHYKOR MORGAN CHECKED BY: APPR: SMILLER DATE: 2015/05/05 DATE: 2015/06/08 REV:	QUALITY SYMBOLS	GENERAL TOLERANCES (UNLESS SPECIFIED)	DIMENSION STYLE	SCALE	DESIGN UNITS	THIRD ANGLE PROJECTION
	▽=0	4 PLACES ± mm INCH	MM ONLY	4:1	METRIC	
	▽=0	3 PLACES ± 0.13				
	▽=0	1 PLACE ± 0.25				
	ANGULAR ± 2 °	DRAFT WHERE APPLICABLE MUST REMAIN WITHIN DIMENSIONS	DRAWN BY: DROSCA CHECKED BY: JCOMERC I APPROVED BY: JCOMERC I	DATE: 8/11/09 DATE: 8/11/09 DATE: 8/11/09	TITLE: ESP 12.5GB 0.062"PCB/0.8MM PITCH 54 CKTS	
			MATERIAL NO.	DOCUMENT NO.	SHEET NO.	
			SEE SHEET 1	SD-76861-120	4 OF 4	
			THIS DRAWING CONTAINS INFORMATION THAT IS PROPRIETARY TO MOLEX INCORPORATED AND SHOULD NOT BE USED WITHOUT WRITTEN PERMISSION			