

THIS DRAWING IS UNPUBLISHED. RELEASED FOR PUBLICATION 20  
 © COPYRIGHT 20 BY - ALL RIGHTS RESERVED.

LOC	DIST	REVISIONS					
CM	00	P	LTR	DESCRIPTION	DATE	DWN	APVD
		G		REVISED PER ECO-15-003291	27JULY15	SC	DZ

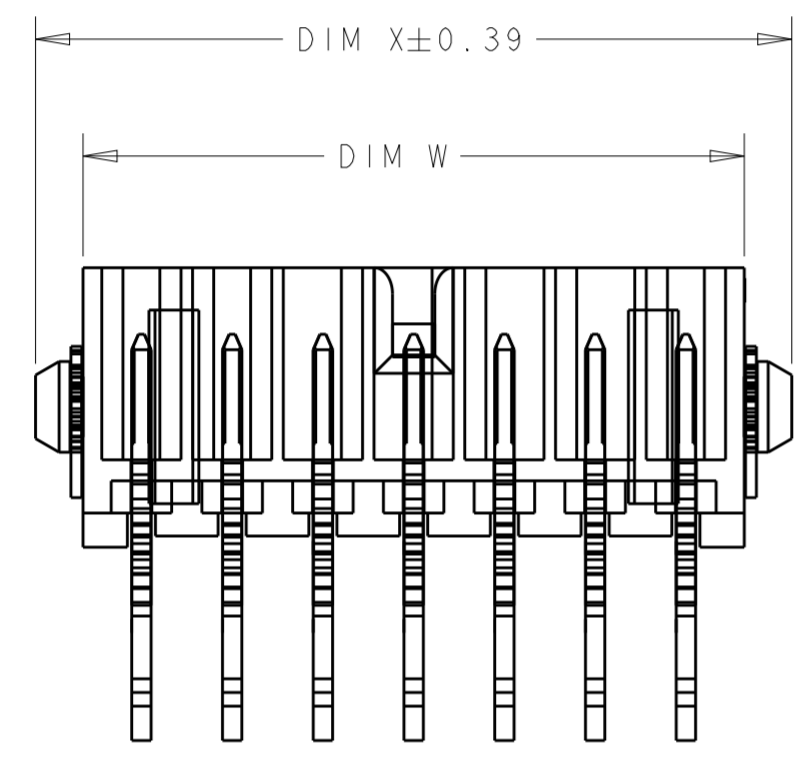
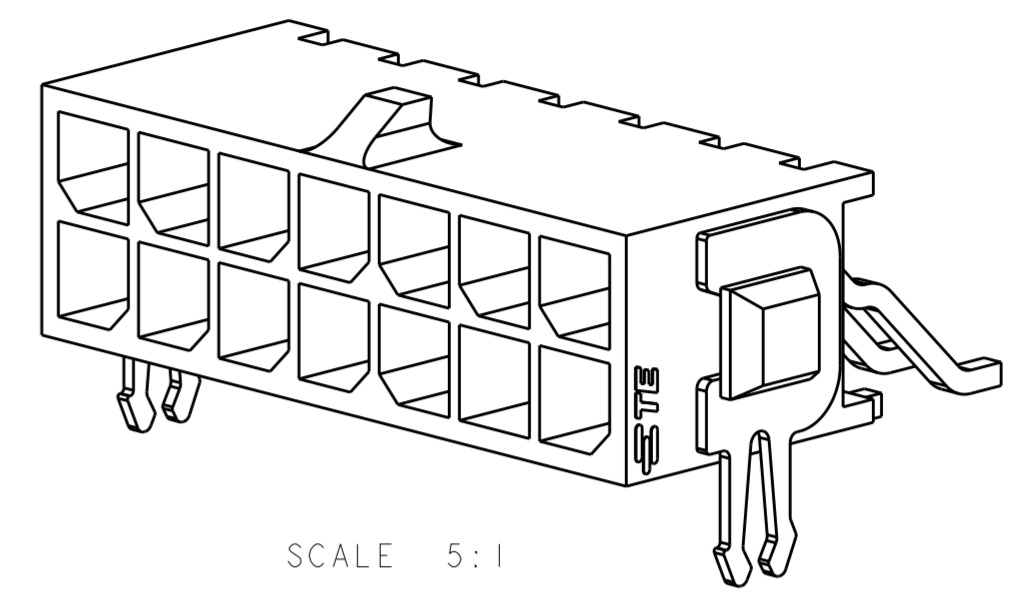
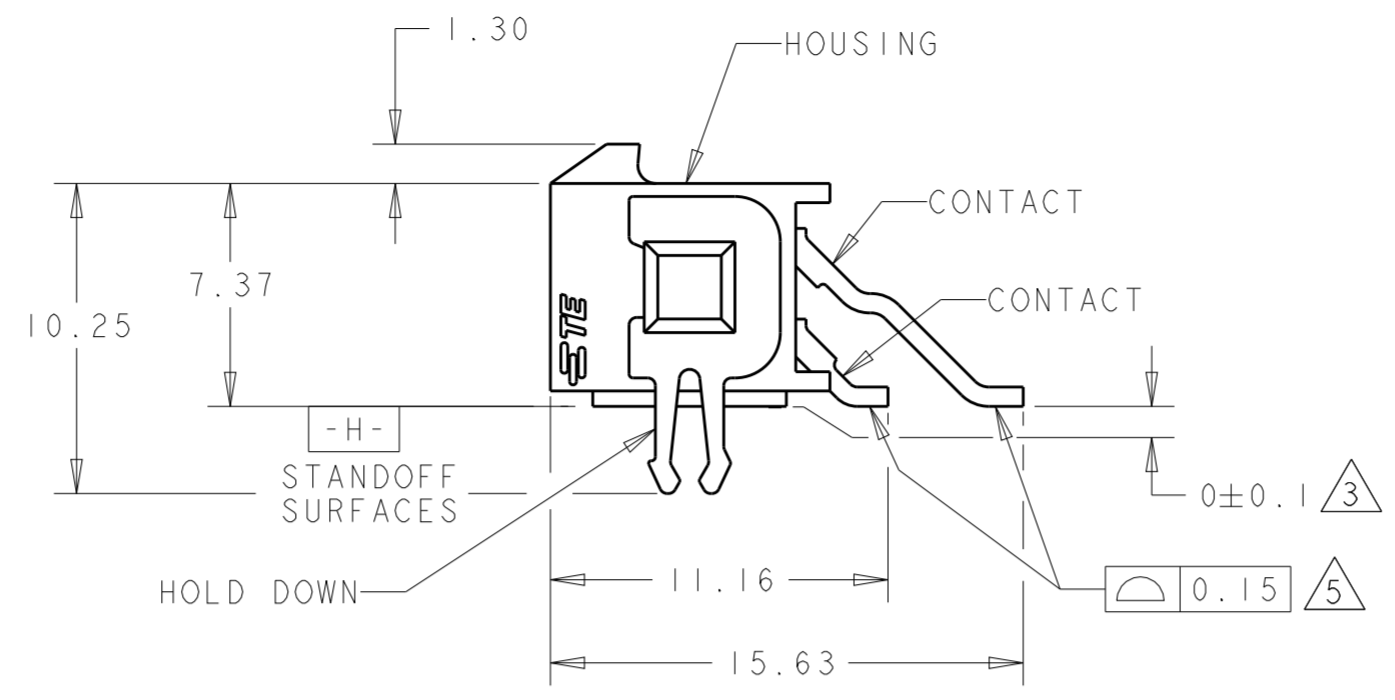
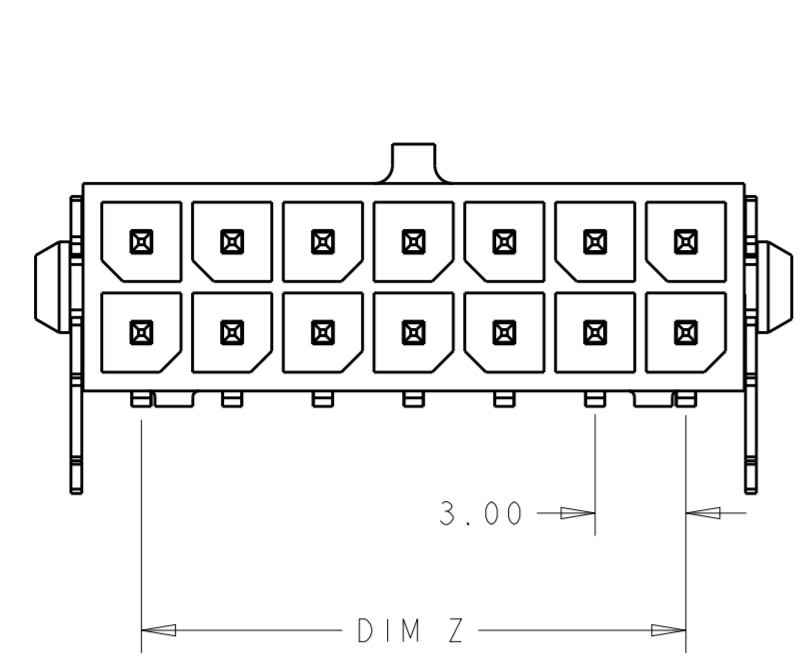

- 1 MATERIAL;  
CONTACTS - BRASS.  
HOUSING - UL 94V-0 RATED HIGH TEMP NYLON,  
COLOR; BLACK.  
HOLD DOWNS - PHOSPHOR BRONZE.
- 2 FINISH;  
CONTACTS - 2.54µm MINIMUM TIN-LEAD OVER 1.27µm  
MINIMUM NICKEL.  
HOLD DOWNS - 2.54µm TIN LEAD.
- 3 DIMENSION APPLIES TO SOLDERTAIL SURFACES  
AND STANDOFF SURFACES.
- 4 RECOMMENDED PCB THICKNESS OF 1.57.
- 5 ALL SOLDERTAILS.
- 6 FINISH;  
CONTACTS - 2.54µm MINIMUM MATTE TIN OVER 1.27µm  
MINIMUM NICKEL.

6	36.86	37.30	33.00	40.00	24	5-794624-4
	33.86	34.30	30.00	37.00	22	5-794624-2
	30.86	31.30	27.00	34.00	20	5-794624-0
	27.86	28.30	24.00	31.00	18	4-794624-8
	24.86	25.30	21.00	28.00	16	4-794624-6
	21.86	22.30	18.00	25.00	14	4-794624-4
	18.86	19.30	15.00	22.00	12	4-794624-2
	15.86	16.30	12.00	19.00	10	4-794624-0
	12.86	13.30	9.00	16.00	8	3-794624-8
	9.86	10.30	6.00	13.00	6	3-794624-6
2	6.86	7.30	3.00	10.00	4	3-794624-4
	3.86	4.30	-	7.00	2	3-794624-2
	36.86	37.30	33.00	40.00	24	2-794624-4
	33.86	34.30	30.00	37.00	22	2-794624-2
	30.86	31.30	27.00	34.00	20	2-794624-0
	27.86	28.30	24.00	31.00	18	1-794624-8
	24.86	25.30	21.00	28.00	16	1-794624-6
	21.86	22.30	18.00	25.00	14	1-794624-4
	18.86	19.30	15.00	22.00	12	1-794624-2
	15.86	16.30	12.00	19.00	10	1-794624-0
FINISH	DIM W	DIM Y	DIM Z	DIM X	NO. OF POSN.	ASSEMBLY

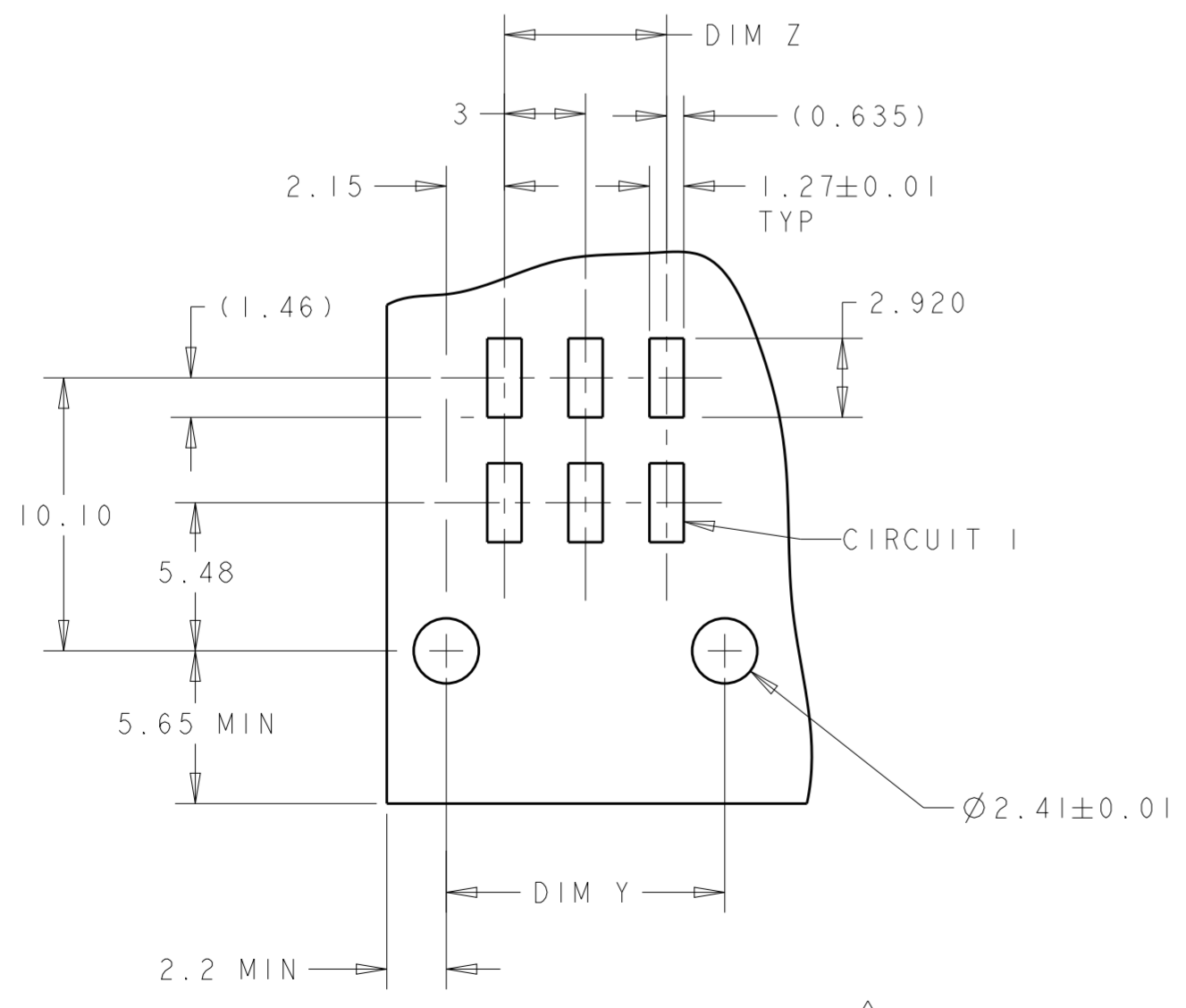

RECOMMENDED PCB LAYOUT (COMPONENT SIDE) 4

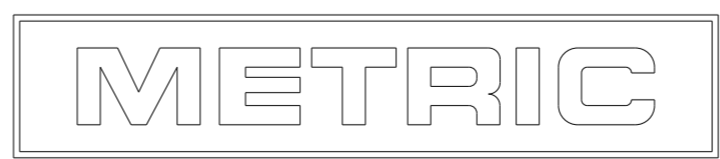

THIS DRAWING IS A CONTROLLED DOCUMENT.

DIMENSIONS: mm	TOLERANCES UNLESS OTHERWISE SPECIFIED:	DWN S. HOOVER 23-MAR-2005	TE Connectivity
		CHK C. JONES 23-MAR-2005	
		APVD C. JONES 23-MAR-2005	
		NAME SURFACE MOUNT, RIGHT ANGLE, MECH. HOLD DOWN, ASSEMBLY, TIN HEADER, DUAL ROW, MICRO MATE-N-LOK (TM)	
MATERIAL 1	SEE TABLE	PRODUCT SPEC -	SIZE A20779
		APPLICATION SPEC -	CAGE CODE C-794624
		WEIGHT -	DRAWING NO. -
		CUSTOMER DRAWING	RESTRICTED TO -

SCALE 4:1 SHEET 1 OF 1 REV G