

SN54ABTH32316, SN74ABTH32316 16-BIT TRI-PORT UNIVERSAL BUS EXCHANGERS

SCBS179E – JUNE 1992 – REVISED MAY 1997

- Members of the Texas Instruments *Widebus+*™ Family
- State-of-the-Art *EPIC-IIB*™ BiCMOS Design Significantly Reduces Power Dissipation
- *UBE*™ (Universal Bus Exchanger) Combines D-Type Latches and D-Type Flip-Flops for Operation in Transparent, Latched, Clocked, or Clock-Enabled Mode
- ESD Protection Exceeds 2000 V Per MIL-STD-883, Method 3015
- Latch-Up Performance Exceeds 500 mA Per JEDEC Standard JESD-17
- Typical V_{OLP} (Output Ground Bounce) < 0.8 V at $V_{CC} = 5$ V, $T_A = 25^\circ\text{C}$
- High-Impedance State During Power Up and Power Down
- Distributed V_{CC} and GND Pin Configuration Minimizes High-Speed Switching Noise
- High-Drive Outputs ($-32\text{-mA } I_{OH}$, $64\text{-mA } I_{OL}$)
- Bus Hold on Data Inputs Eliminates the Need for External Pullup/Pulldown Resistors
- Package Options Include 80-Pin Plastic Thin Quad Flat (PN) Package With $12 \times 12\text{-mm}$ Body Using 0.5-mm Lead Pitch and 84-Pin Ceramic Quad Flat (HT) Package

'ABTH32316 . . . PN PACKAGE
(TOP VIEW)

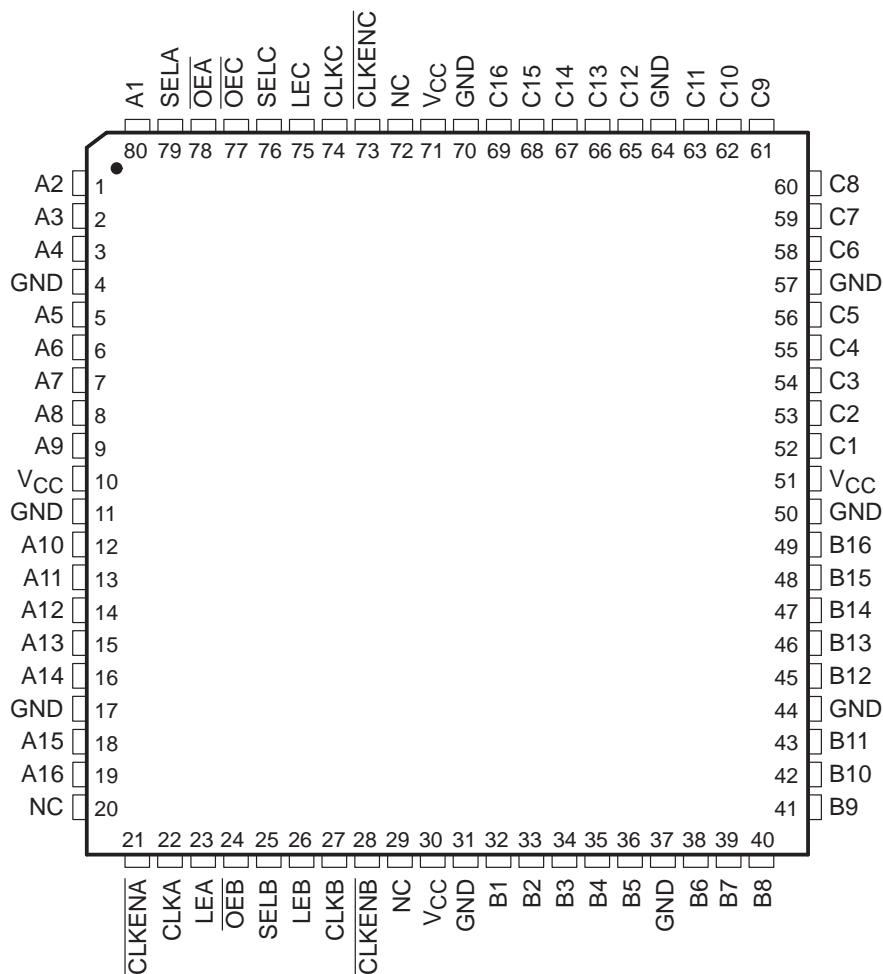

NC – No internal connection



Please be aware that an important notice concerning availability, standard warranty, and use in critical applications of Texas Instruments semiconductor products and disclaimers thereto appears at the end of this data sheet.

Widebus+, EPIC-IIB, and UBE are trademarks of Texas Instruments Incorporated.

PRODUCTION DATA information is current as of publication date. Products conform to specifications per the terms of Texas Instruments standard warranty. Production processing does not necessarily include testing of all parameters.



POST OFFICE BOX 655303 • DALLAS, TEXAS 75265

Copyright © 1997, Texas Instruments Incorporated

SN54ABTH32316, SN74ABTH32316 16-BIT TRI-PORT UNIVERSAL BUS EXCHANGERS

SCBS179E – JUNE 1992 – REVISED MAY 1997

SN54ABTH32316 . . . HT PACKAGE
(TOP VIEW)

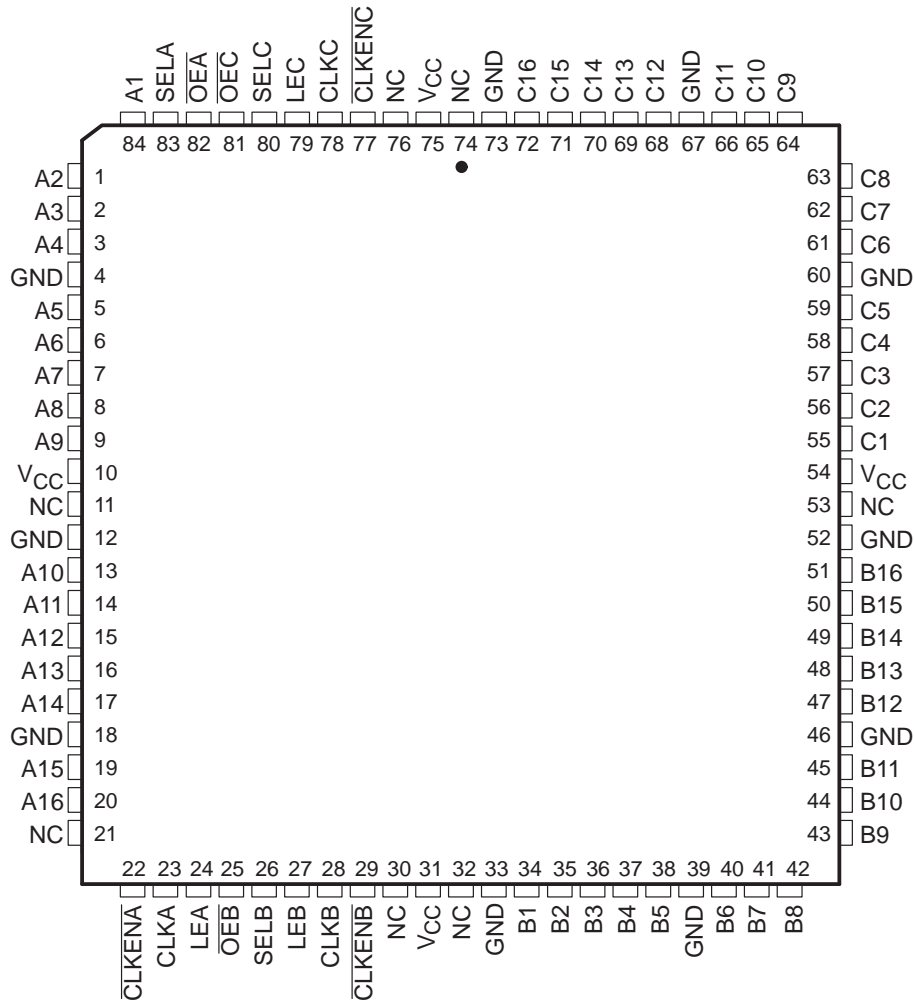

NC – No internal connection

description

The 'ABTH32316 consist of three 16-bit registered input/output (I/O) ports. These registers combine D-type latches and flip-flops to allow data flow in transparent, latch, and clock modes. Data from one input port can be exchanged to one or more of the other ports. Because of the universal storage element, multiple combinations of real-time and stored data can be exchanged among the three ports.

Data flow in each direction is controlled by the output-enable (\overline{OEA} , \overline{OEB} , and \overline{OEC}), select-control (SELA, SELB, and SELC), latch-enable (LEA, LEB, and LEC), and clock (CLKA, CLKB, and CLKC) inputs. The A data register operates in the transparent mode when LEA is high. When LEA is low, data is latched if CLKA is held at a high or low logic level. If LEA and clock-enable A (\overline{CLKENA}) are low, data is stored on the low-to-high transition of CLKA. Output data selection is accomplished by the select-control pins. All three ports have active-low output enables, so when the output-enable input is low, the outputs are active; when the output-enable input is high, the outputs are in the high-impedance state.

When V_{CC} is between 0 and 2.1 V, the device is in the high-impedance state during power up or power down. However, to ensure the high-impedance state above 2.1 V, \overline{OE} should be tied to V_{CC} through a pullup resistor; the minimum value of the resistor is determined by the current-sinking capability of the driver.



POST OFFICE BOX 655303 • DALLAS, TEXAS 75265

description (continued)

Active bus-hold circuitry is provided to hold unused or floating data inputs at a valid logic level.

The SN54ABTH32316 is characterized for operation over the full military temperature range of -55°C to 125°C .
 The SN74ABTH32316 is characterized for operation from -40°C to 85°C .

Function Tables

STORAGE†

INPUTS				OUTPUT
CLKENA	CLKA	LEA	A	
H	X	L	X	Q_0^{\ddagger}
L	↑	L	L	L
L	↑	L	H	H
X	H	L	X	Q_0^{\ddagger}
X	L	L	X	Q_0^{\ddagger}
X	X	H	L	L
X	X	H	H	H

† A-port register shown. B and C ports are similar but use $\overline{\text{CLKENB}}$, $\overline{\text{CLKENC}}$, CLKB , CLKC , LEB , and LEC .

‡ Output level before the indicated steady-state input conditions were established

A-PORT OUTPUT

INPUTS		OUTPUT A
$\overline{\text{OEA}}$	SELA	
H	X	Z
L	H	Output of C register
L	L	Output of B register

B-PORT OUTPUT

INPUTS		OUTPUT B
$\overline{\text{OEB}}$	SELB	
H	X	Z
L	H	Output of A register
L	L	Output of C register

C-PORT OUTPUT

INPUTS		OUTPUT C
$\overline{\text{OEC}}$	SELC	
H	X	Z
L	H	Output of B register
L	L	Output of A register

SN54ABTH32316, SN74ABTH32316 16-BIT TRI-PORT UNIVERSAL BUS EXCHANGERS

SCBS179E – JUNE 1992 – REVISED MAY 1997

logic diagram (positive logic)

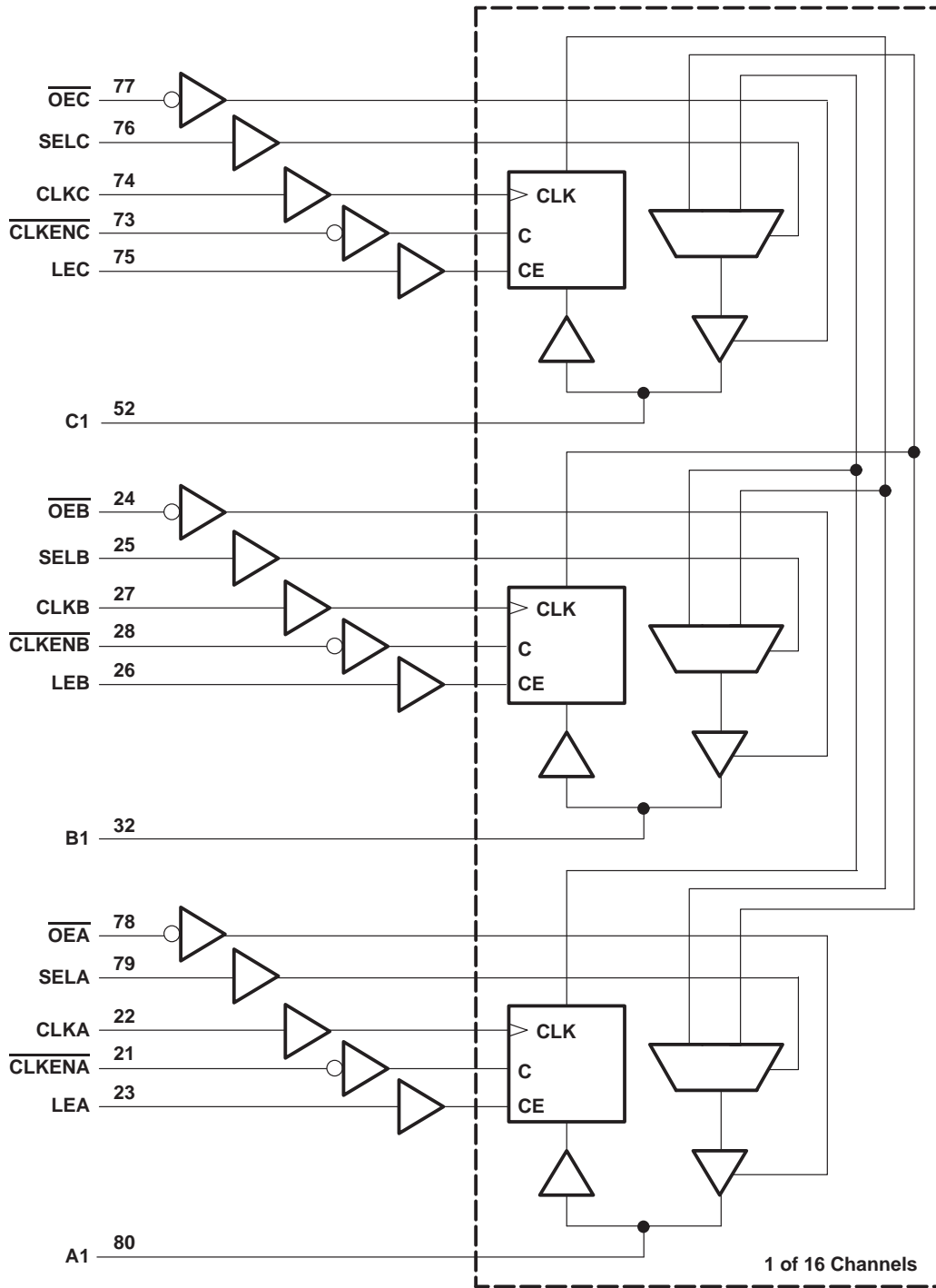

Pin numbers shown are for the PN package.

SN54ABTH32316, SN74ABTH32316 16-BIT TRI-PORT UNIVERSAL BUS EXCHANGERS

SCBS179E – JUNE 1992 – REVISED MAY 1997

absolute maximum ratings over operating free-air temperature range (unless otherwise noted)†

Supply voltage range, V_{CC}	–0.5 V to 7 V
Input voltage range, V_I (except I/O ports) (see Note 1)	–0.5 V to 7 V
Voltage range applied to any output in the high or power-off state, V_O	–0.5 V to 5.5 V
Current into any output in the low state, I_O : SN54ABTH32316	96 mA
SN74ABTH32316	128 mA
Input clamp current, I_{IK} ($V_I < 0$)	–18 mA
Output clamp current, I_{OK} ($V_O < 0$)	–50 mA
Package thermal impedance, θ_{JA} (see Note 2): PN package	62°C/W
Storage temperature range, T_{stg}	–65°C to 150°C

† Stresses beyond those listed under “absolute maximum ratings” may cause permanent damage to the device. These are stress ratings only, and functional operation of the device at these or any other conditions beyond those indicated under “recommended operating conditions” is not implied. Exposure to absolute-maximum-rated conditions for extended periods may affect device reliability.

- NOTES: 1. The input and output negative-voltage ratings may be exceeded if the input and output clamp-current ratings are observed.
2. The package thermal impedance is calculated in accordance with EIA/JEDEC Std JESD51.

recommended operating conditions (see Note 3)

		SN54ABTH32316		SN74ABTH32316		UNIT
		MIN	MAX	MIN	MAX	
V_{CC}	Supply voltage	4.5	5.5	4.5	5.5	V
V_{IH}	High-level input voltage	2		2		V
V_{IL}	Low-level input voltage		0.8		0.8	V
V_I	Input voltage	0	V_{CC}	0	V_{CC}	V
I_{OH}	High-level output current		–24		–32	mA
I_{OL}	Low-level output current		48		64	mA
$\Delta t/\Delta v$	Input transition rise or fall rate	Outputs enabled			10	ns/V
$\Delta t/\Delta V_{CC}$	Power-up ramp rate	200		200		μs/V
T_A	Operating free-air temperature	–55	125	–40	85	°C

NOTE 3: Unused control pins must be held high or low to prevent them from floating.



SN54ABTH32316, SN74ABTH32316 16-BIT TRI-PORT UNIVERSAL BUS EXCHANGERS

SCBS179E – JUNE 1992 – REVISED MAY 1997

electrical characteristics over recommended operating free-air temperature range (unless otherwise noted)

PARAMETER		TEST CONDITIONS	SN54ABTH32316			SN74ABTH32316			UNIT
			MIN	TYP†	MAX	MIN	TYP†	MAX	
V_{IK}		$V_{CC} = 4.5\text{ V}$, $I_I = -18\text{ mA}$			-1.2			-1.2	V
V_{OH}		$V_{CC} = 4.5\text{ V}$, $I_{OH} = -3\text{ mA}$			2.5			2.5	V
		$V_{CC} = 5\text{ V}$, $I_{OH} = -3\text{ mA}$			3			3	
		$V_{CC} = 4.5\text{ V}$			2			2	
V_{OL}		$V_{CC} = 4.5\text{ V}$			0.55				V
								0.55	
V_{hys}					100			100	mV
I_I	Control inputs	$V_{CC} = 0\text{ to }5.5\text{ V}$, $V_I = V_{CC}\text{ or GND}$			± 1			± 1	μA
	A, B, or C ports	$V_{CC} = 2.1\text{ V to }5.5\text{ V}$, $V_I = V_{CC}\text{ or GND}$			± 100			± 20	
$I_I(\text{hold})$	A, B, or C ports	$V_{CC} = 4.5\text{ V}$			100			100	μA
					-100			-100	
I_{OZPU}^\ddagger		$V_{CC} = 0\text{ to }2.1\text{ V}$, $V_O = 0.5\text{ V to }2.7\text{ V}$, $\overline{OE} = X$			± 50			± 50	μA
I_{OZPD}^\ddagger		$V_{CC} = 2.1\text{ V to }0$, $V_O = 0.5\text{ V to }2.7\text{ V}$, $\overline{OE} = X$			± 50			± 50	μA
I_{off}		$V_{CC} = 0$, $V_I\text{ or }V_O \leq 4.5\text{ V}$			± 100			± 100	μA
I_{CEX}		$V_{CC} = 5.5\text{ V}$, $V_O = 5.5\text{ V}$			50			50	μA
I_O^\S		$V_{CC} = 5.5\text{ V}$, $V_O = 2.5\text{ V}$	-50	-100	-180	-50	-100	-180	mA
I_{CC}		$V_{CC} = 5.5\text{ V}$, $I_O = 0$, $V_I = V_{CC}\text{ or GND}$			2			2	mA
				40			40		
				1			1		
ΔI_{CC}^\parallel		$V_{CC} = 5.5\text{ V}$, One input at 3.4 V, Other inputs at V_{CC} or GND			1			0.5	mA
C_i	Control inputs	$V_I = 2.5\text{ V or }0.5\text{ V}$			3			3	pF
C_{io}	A, B, or C ports	$V_O = 2.5\text{ V or }0.5\text{ V}$			11.5			11.5	pF

† All typical values are at $V_{CC} = 5\text{ V}$, $T_A = 25^\circ\text{C}$.

‡ This parameter is specified by characterization.

§ Not more than one output should be tested at a time, and the duration of the test should not exceed one second.

¶ This is the increase in supply current for each input that is at the specified TTL voltage level rather than V_{CC} or GND.

timing requirements over recommended ranges of supply voltage and operating free-air temperature (unless otherwise noted) (see Figure 1)

		SN54ABTH32316		SN74ABTH32316		UNIT
		MIN	MAX	MIN	MAX	
f_{clock}	Clock frequency	0	150	0	150	MHz
t_w	Pulse duration	LE high	3.3		3.3	ns
		CLK high or low	3.3		3.3	
t_{su}	Setup time	A, B, or C before CLK \uparrow	2.6		2.4	ns
		A or B before LE \downarrow	2.5		2.1	
		CLKEN before CLK \uparrow	3.5		3.2	
t_h	Hold time	A, B, or C after CLK \uparrow	1.8		1.4	ns
		A or B after LE \downarrow	2.4		2.1	
		CLKEN after CLK \uparrow	1.5		1.1	



SN54ABTH32316, SN74ABTH32316 16-BIT TRI-PORT UNIVERSAL BUS EXCHANGERS

SCBS179E – JUNE 1992 – REVISED MAY 1997

switching characteristics over recommended ranges of supply voltage and operating free-air temperature, $C_L = 50$ pF (unless otherwise noted) (see Figure 1)

PARAMETER	FROM (INPUT)	TO (OUTPUT)	SN54ABTH32316		SN74ABTH32316		UNIT
			MIN	MAX	MIN	MAX	
f_{max}			150		150		MHz
t_{PLH}	A, B, or C	C, B, or A	0.8	6.5	1.4	6.1	ns
t_{PHL}			0.5	6.8	1.1	6.6	
t_{PLH}	SEL	A, B, or C	0.8	6.7	1.4	6.5	ns
t_{PHL}			0.8	6.8	1.8	6.5	
t_{PLH}	LE	A, B, or C	1.5	8	2.6	7.5	ns
t_{PHL}			1.5	7.4	2.6	6.9	
t_{PLH}	CLK	A, B, or C	1.5	8	2.5	7.5	ns
t_{PHL}			1.5	7.2	2.5	6.7	
t_{PZH}	\overline{OE}	A, B, or C	0.8	6.7	1.5	6.4	ns
t_{PZL}			1.5	7.1	2.4	6.8	
t_{PHZ}	\overline{OE}	A, B, or C	0.8	7.2	1.5	6	ns
t_{PLZ}			0.8	6.4	1.9	6.1	

SN54ABTH32316, SN74ABTH32316 16-BIT TRI-PORT UNIVERSAL BUS EXCHANGERS

SCBS179E – JUNE 1992 – REVISED MAY 1997

PARAMETER MEASUREMENT INFORMATION

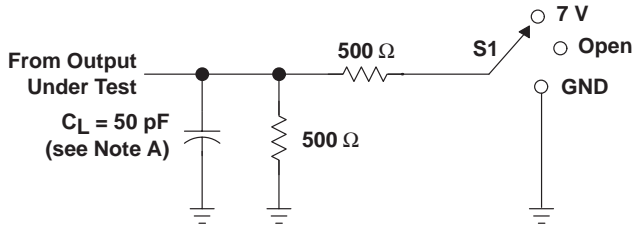

LOAD CIRCUIT

TEST	S1
t_{PLH}/t_{PHL}	Open
t_{PLZ}/t_{PZL}	7 V
t_{PHZ}/t_{PZH}	Open

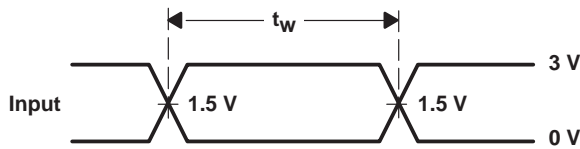

VOLTAGE WAVEFORMS
PULSE DURATION

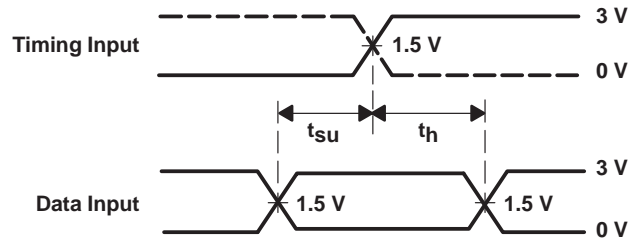

VOLTAGE WAVEFORMS
SETUP AND HOLD TIMES

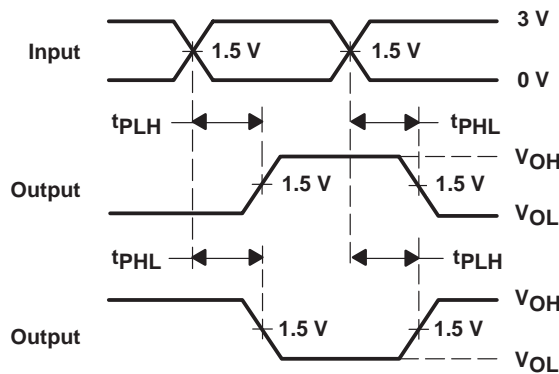

VOLTAGE WAVEFORMS
PROPAGATION DELAY TIMES
INVERTING AND NONINVERTING OUTPUTS

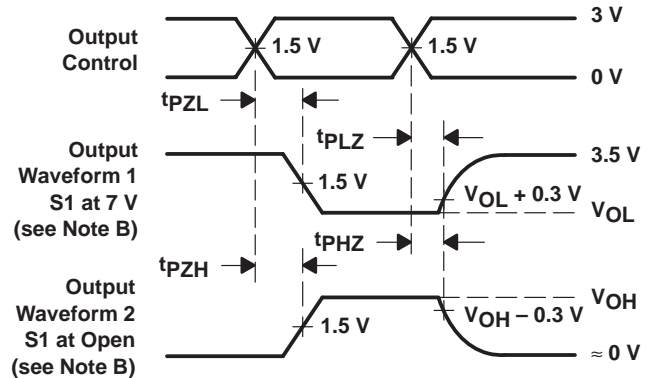



VOLTAGE WAVEFORMS
ENABLE AND DISABLE TIMES
LOW- AND HIGH-LEVEL ENABLING

- NOTES: A. C_L includes probe and jig capacitance.
 B. Waveform 1 is for an output with internal conditions such that the output is low except when disabled by the output control. Waveform 2 is for an output with internal conditions such that the output is high except when disabled by the output control.
 C. All input pulses are supplied by generators having the following characteristics: $PRR \leq 10 \text{ MHz}$, $Z_O = 50 \Omega$, $t_r \leq 2.5 \text{ ns}$, $t_f \leq 2.5 \text{ ns}$.
 D. The outputs are measured one at a time with one transition per measurement.

Figure 1. Load Circuit and Voltage Waveforms

PACKAGING INFORMATION

Orderable Device	Status (1)	Package Type	Package Drawing	Pins	Package Qty	Eco Plan (2)	Lead/Ball Finish (6)	MSL Peak Temp (3)	Op Temp (°C)	Device Marking (4/5)	Samples
5962-9680801QXA	ACTIVE	CFP	HT	84	250	TBD	POST-PLATE	N / A for Pkg Type	-55 to 125	5962-9680801QX A SNJ54ABTH32316 HT	
SN74ABTH32316PN	ACTIVE	LQFP	PN	80	119	Green (RoHS & no Sb/Br)	CU NIPDAU	Level-3-260C-168 HR	-40 to 85	ABTH32316	
SNJ54ABTH32316HT	ACTIVE	CFP	HT	84	250	TBD	POST-PLATE	N / A for Pkg Type	-55 to 125	5962-9680801QX A SNJ54ABTH32316 HT	

(1) The marketing status values are defined as follows:

ACTIVE: Product device recommended for new designs.

LIFEBUY: TI has announced that the device will be discontinued, and a lifetime-buy period is in effect.

NRND: Not recommended for new designs. Device is in production to support existing customers, but TI does not recommend using this part in a new design.

PREVIEW: Device has been announced but is not in production. Samples may or may not be available.

OBSELETE: TI has discontinued the production of the device.

(2) Eco Plan - The planned eco-friendly classification: Pb-Free (RoHS), Pb-Free (RoHS Exempt), or Green (RoHS & no Sb/Br) - please check <http://www.ti.com/productcontent> for the latest availability information and additional product content details.

TBD: The Pb-Free/Green conversion plan has not been defined.

Pb-Free (RoHS): TI's terms "Lead-Free" or "Pb-Free" mean semiconductor products that are compatible with the current RoHS requirements for all 6 substances, including the requirement that lead not exceed 0.1% by weight in homogeneous materials. Where designed to be soldered at high temperatures, TI Pb-Free products are suitable for use in specified lead-free processes.

Pb-Free (RoHS Exempt): This component has a RoHS exemption for either 1) lead-based flip-chip solder bumps used between the die and package, or 2) lead-based die adhesive used between the die and leadframe. The component is otherwise considered Pb-Free (RoHS compatible) as defined above.

Green (RoHS & no Sb/Br): TI defines "Green" to mean Pb-Free (RoHS compatible), and free of Bromine (Br) and Antimony (Sb) based flame retardants (Br or Sb do not exceed 0.1% by weight in homogeneous material)

(3) MSL, Peak Temp. - The Moisture Sensitivity Level rating according to the JEDEC industry standard classifications, and peak solder temperature.

(4) There may be additional marking, which relates to the logo, the lot trace code information, or the environmental category on the device.

(5) Multiple Device Markings will be inside parentheses. Only one Device Marking contained in parentheses and separated by a "~" will appear on a device. If a line is indented then it is a continuation of the previous line and the two combined represent the entire Device Marking for that device.

⁽⁶⁾ Lead/Ball Finish - Orderable Devices may have multiple material finish options. Finish options are separated by a vertical ruled line. Lead/Ball Finish values may wrap to two lines if the finish value exceeds the maximum column width.

Important Information and Disclaimer:The information provided on this page represents TI's knowledge and belief as of the date that it is provided. TI bases its knowledge and belief on information provided by third parties, and makes no representation or warranty as to the accuracy of such information. Efforts are underway to better integrate information from third parties. TI has taken and continues to take reasonable steps to provide representative and accurate information but may not have conducted destructive testing or chemical analysis on incoming materials and chemicals. TI and TI suppliers consider certain information to be proprietary, and thus CAS numbers and other limited information may not be available for release.

In no event shall TI's liability arising out of such information exceed the total purchase price of the TI part(s) at issue in this document sold by TI to Customer on an annual basis.

OTHER QUALIFIED VERSIONS OF SN54ABTH32316, SN74ABTH32316 :

- Catalog: [SN74ABTH32316](#)
- Military: [SN54ABTH32316](#)

NOTE: Qualified Version Definitions:

- Catalog - TI's standard catalog product
- Military - QML certified for Military and Defense Applications

HT (S-CQFP-F84)

CERAMIC QUAD FLATPACK

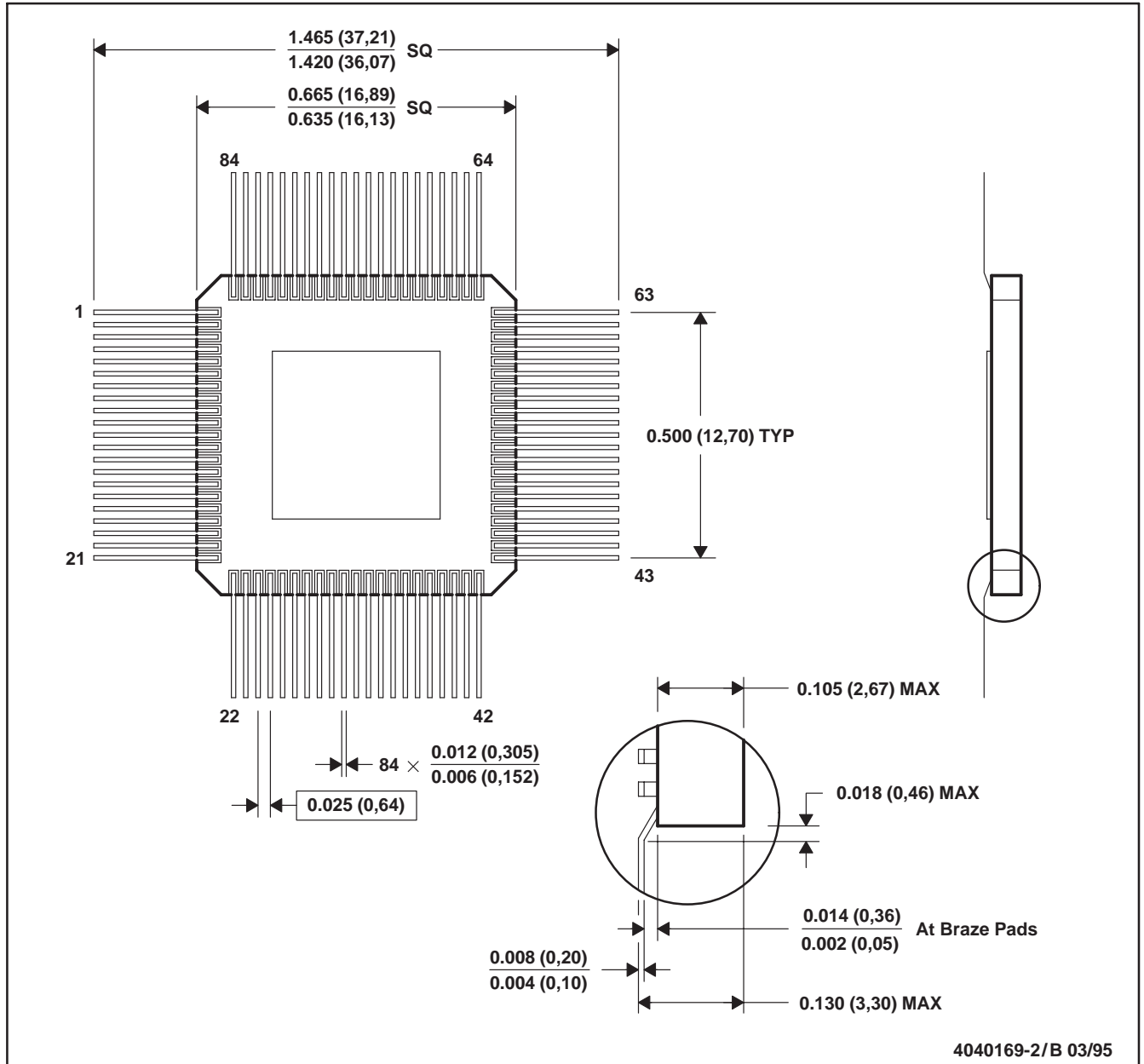

- NOTES:
- A. All linear dimensions are in inches (millimeters).
 - B. This drawing is subject to change without notice.
 - C. This package is hermetically sealed with a metal lid.
 - D. The terminals are gold plated.
 - E. Falls within JEDEC MO-090 AA

PN (S-PQFP-G80)

PLASTIC QUAD FLATPACK

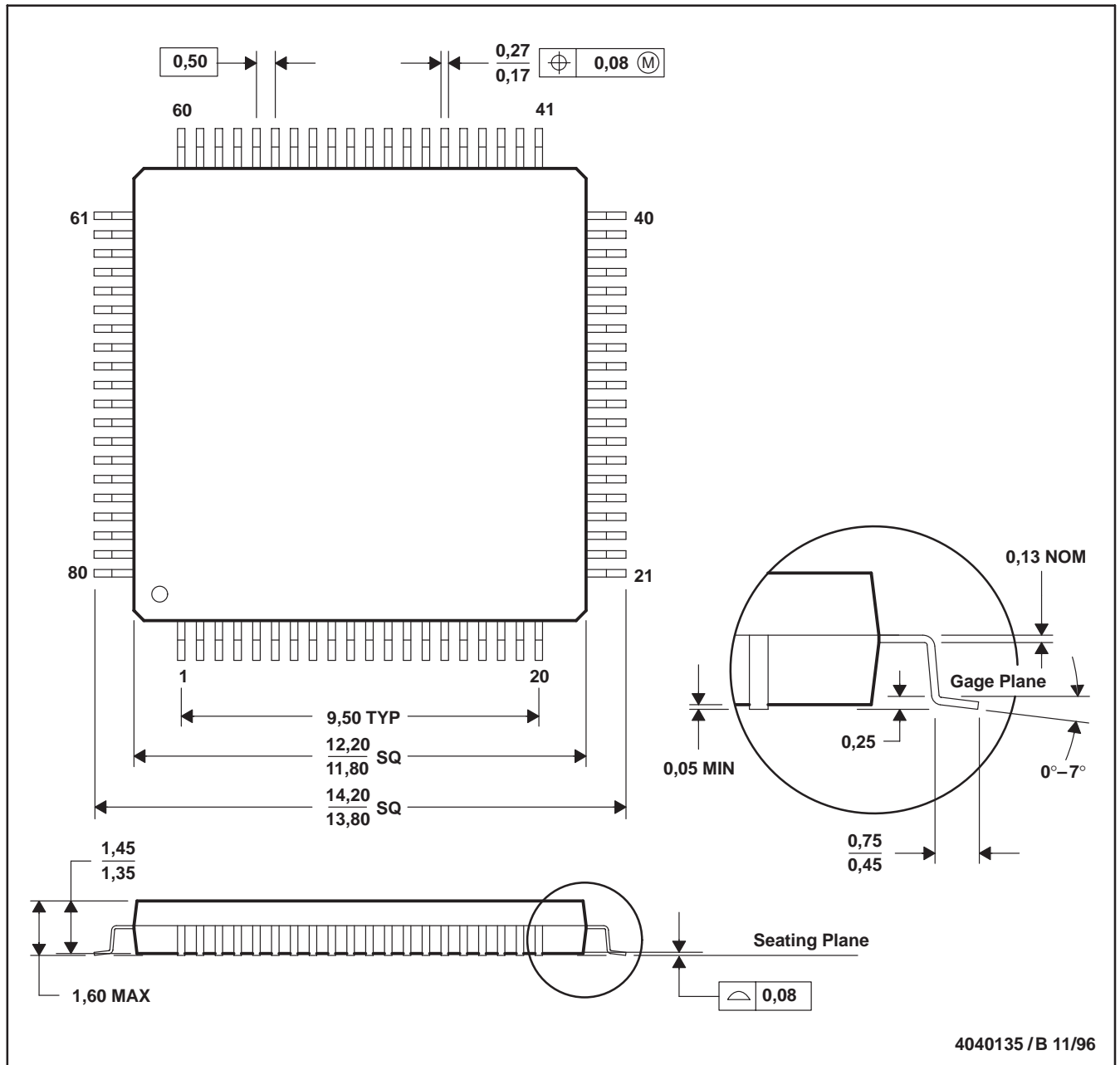

- NOTES: A. All linear dimensions are in millimeters.
 B. This drawing is subject to change without notice.
 C. Falls within JEDEC MS-026

IMPORTANT NOTICE

Texas Instruments Incorporated and its subsidiaries (TI) reserve the right to make corrections, enhancements, improvements and other changes to its semiconductor products and services per JESD46, latest issue, and to discontinue any product or service per JESD48, latest issue. Buyers should obtain the latest relevant information before placing orders and should verify that such information is current and complete. All semiconductor products (also referred to herein as "components") are sold subject to TI's terms and conditions of sale supplied at the time of order acknowledgment.

TI warrants performance of its components to the specifications applicable at the time of sale, in accordance with the warranty in TI's terms and conditions of sale of semiconductor products. Testing and other quality control techniques are used to the extent TI deems necessary to support this warranty. Except where mandated by applicable law, testing of all parameters of each component is not necessarily performed.

TI assumes no liability for applications assistance or the design of Buyers' products. Buyers are responsible for their products and applications using TI components. To minimize the risks associated with Buyers' products and applications, Buyers should provide adequate design and operating safeguards.

TI does not warrant or represent that any license, either express or implied, is granted under any patent right, copyright, mask work right, or other intellectual property right relating to any combination, machine, or process in which TI components or services are used. Information published by TI regarding third-party products or services does not constitute a license to use such products or services or a warranty or endorsement thereof. Use of such information may require a license from a third party under the patents or other intellectual property of the third party, or a license from TI under the patents or other intellectual property of TI.

Reproduction of significant portions of TI information in TI data books or data sheets is permissible only if reproduction is without alteration and is accompanied by all associated warranties, conditions, limitations, and notices. TI is not responsible or liable for such altered documentation. Information of third parties may be subject to additional restrictions.

Resale of TI components or services with statements different from or beyond the parameters stated by TI for that component or service voids all express and any implied warranties for the associated TI component or service and is an unfair and deceptive business practice. TI is not responsible or liable for any such statements.

Buyer acknowledges and agrees that it is solely responsible for compliance with all legal, regulatory and safety-related requirements concerning its products, and any use of TI components in its applications, notwithstanding any applications-related information or support that may be provided by TI. Buyer represents and agrees that it has all the necessary expertise to create and implement safeguards which anticipate dangerous consequences of failures, monitor failures and their consequences, lessen the likelihood of failures that might cause harm and take appropriate remedial actions. Buyer will fully indemnify TI and its representatives against any damages arising out of the use of any TI components in safety-critical applications.

In some cases, TI components may be promoted specifically to facilitate safety-related applications. With such components, TI's goal is to help enable customers to design and create their own end-product solutions that meet applicable functional safety standards and requirements. Nonetheless, such components are subject to these terms.

No TI components are authorized for use in FDA Class III (or similar life-critical medical equipment) unless authorized officers of the parties have executed a special agreement specifically governing such use.

Only those TI components which TI has specifically designated as military grade or "enhanced plastic" are designed and intended for use in military/aerospace applications or environments. Buyer acknowledges and agrees that any military or aerospace use of TI components which have **not** been so designated is solely at the Buyer's risk, and that Buyer is solely responsible for compliance with all legal and regulatory requirements in connection with such use.

TI has specifically designated certain components as meeting ISO/TS16949 requirements, mainly for automotive use. In any case of use of non-designated products, TI will not be responsible for any failure to meet ISO/TS16949.

Products

Audio	www.ti.com/audio
Amplifiers	amplifier.ti.com
Data Converters	dataconverter.ti.com
DLP® Products	www.dlp.com
DSP	dsp.ti.com
Clocks and Timers	www.ti.com/clocks
Interface	interface.ti.com
Logic	logic.ti.com
Power Mgmt	power.ti.com
Microcontrollers	microcontroller.ti.com
RFID	www.ti-rfid.com
OMAP Applications Processors	www.ti.com/omap
Wireless Connectivity	www.ti.com/wirelessconnectivity

Applications

Automotive and Transportation	www.ti.com/automotive
Communications and Telecom	www.ti.com/communications
Computers and Peripherals	www.ti.com/computers
Consumer Electronics	www.ti.com/consumer-apps
Energy and Lighting	www.ti.com/energy
Industrial	www.ti.com/industrial
Medical	www.ti.com/medical
Security	www.ti.com/security
Space, Avionics and Defense	www.ti.com/space-avionics-defense
Video and Imaging	www.ti.com/video

TI E2E Community

e2e.ti.com