

CDC339 CLOCK DRIVER WITH 3-STATE OUTPUTS

SCAS331 – DECEMBER 1992 – REVISED MARCH 1994

- Low Output Skew, Low Pulse Skew for Clock-Distribution and Clock-Generation Applications
- TTL-Compatible Inputs and Outputs
- Distributes One Clock Input to Eight Outputs
 - Four Same-Frequency Outputs
 - Four Half-Frequency Outputs
- Distributed V_{CC} and Ground Pins Reduce Switching Noise
- High-Drive Outputs ($-48\text{-mA } I_{OH}$, $48\text{-mA } I_{OL}$)
- State-of-the-Art EPIC-IIB™ BiCMOS Design Significantly Reduces Power Dissipation
- Package Options Include Plastic Small-Outline (DW) and Shrink Small-Outline (DB) Packages

DB OR DW PACKAGE
(TOP VIEW)

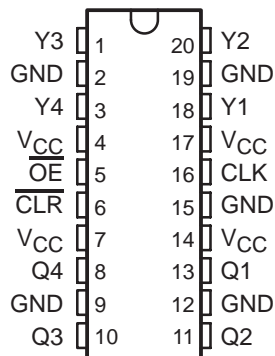

description

The CDC339 is a high-performance, low-skew clock driver. It is specifically designed for applications requiring synchronized output signals at both the primary clock frequency and one-half the primary clock frequency. The four Y outputs switch in phase and at the same frequency as the clock (CLK) input. The four Q outputs switch at one-half the frequency of CLK.

When the output-enable (\overline{OE}) input is low and the clear (\overline{CLR}) input is high, the Y outputs follow CLK and the Q outputs toggle on low-to-high transitions of CLK. Taking CLR low asynchronously resets the Q outputs to the low level. When \overline{OE} is high, the outputs are in the high-impedance state.

The CDC339 is characterized for operation from -40°C to 85°C .

FUNCTION TABLE

INPUTS			OUTPUTS	
\overline{OE}	\overline{CLR}	CLK	Y1–Y4	Q1–Q4
H	X	X	Z	Z
L	L	L	L	L
L	L	H	H	L
L	H	L	L	Q_0^{\dagger}
L	H	\uparrow	H	\overline{Q}_0^{\dagger}

† The level of the Q outputs before the indicated steady-state input conditions were established.



Please be aware that an important notice concerning availability, standard warranty, and use in critical applications of Texas Instruments semiconductor products and disclaimers thereto appears at the end of this data sheet.

EPIC-IIB is a trademark of Texas Instruments Incorporated.

PRODUCTION DATA information is current as of publication date. Products conform to specifications per the terms of Texas Instruments standard warranty. Production processing does not necessarily include testing of all parameters.



POST OFFICE BOX 655303 • DALLAS, TEXAS 75265

Copyright © 1994, Texas Instruments Incorporated

CDC339 CLOCK DRIVER WITH 3-STATE OUTPUTS

SCAS331 – DECEMBER 1992 – REVISED MARCH 1994

logic symbol†

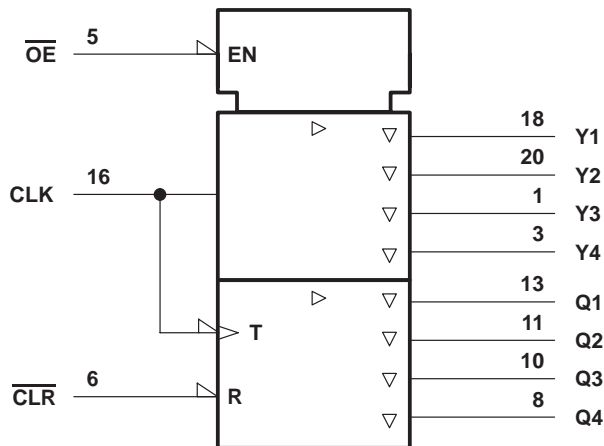

† This symbol is in accordance with ANSI/IEEE Std 91-1984 and IEC Publication 617-12.

logic diagram (positive logic)

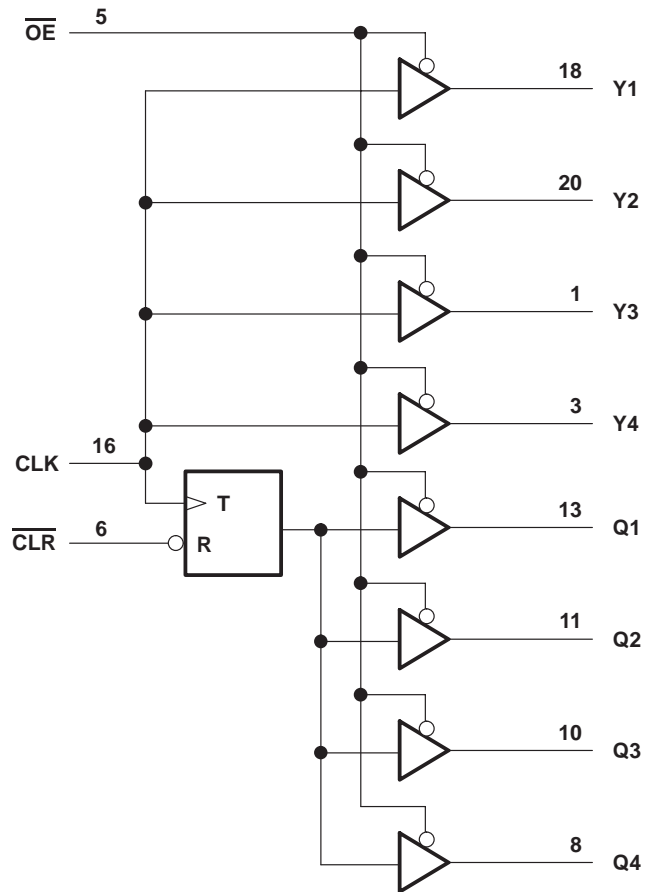

absolute maximum ratings over operating free-air temperature range (unless otherwise noted)‡

Supply voltage range, V_{CC}	-0.5 V to 7 V
Input voltage range, V_I (see Note 1)	-0.5 V to 7 V
Voltage range applied to any output in the disabled or power-off state, V_O	-0.5 V to 5.5 V
Current into any output in the low state, I_O	96 mA
Input clamp current, I_{IK} ($V_I < 0$)	-18 mA
Output clamp current, I_{OK} ($V_O < 0$)	-50 mA
Maximum power dissipation at $T_A = 55^\circ\text{C}$ (in still air) (see Note 2): DB package	0.6 W
..... DW package	1.6 W
Storage temperature range, T_{stg}	-65°C to 150°C

‡ Stresses beyond those listed under "absolute maximum ratings" may cause permanent damage to the device. These are stress ratings only, and functional operation of the device at these or any other conditions beyond those indicated under "recommended operating conditions" is not implied. Exposure to absolute-maximum-rated conditions for extended periods may affect device reliability.

NOTES: 1. The input and output negative-voltage ratings may be exceeded if the input and output clamp-current ratings are observed.
2. The maximum package power dissipation is calculated using a junction temperature of 150°C and a board trace length of 750 mils. For more information, refer to the *Package Thermal Considerations* application note in the 1994 *ABT Advanced BiCMOS Technology Data Book*, literature number SCBD002B.

CDC339 CLOCK DRIVER WITH 3-STATE OUTPUTS

SCAS331 – DECEMBER 1992 – REVISED MARCH 1994

recommended operating conditions (see Note 3)

		MIN	MAX	UNIT
V_{CC}	Supply voltage	4.75	5.25	V
V_{IH}	High-level input voltage	2		V
V_{IL}	Low-level input voltage		0.8	V
V_I	Input voltage	0	V_{CC}	V
I_{OH}	High-level output current		-48	mA
I_{OL}	Low-level output current		48	mA
f_{clock}	Input clock frequency		80	MHz
T_A	Operating free-air temperature	-40	85	°C

NOTE 3: Unused pins (input or I/O) must be held high or low.

electrical characteristics over recommended operating free-air temperature range (unless otherwise noted)

PARAMETER	TEST CONDITIONS		MIN	TYP†	MAX	UNIT
V_{IK}	$V_{CC} = 4.75$ V,	$I_I = -18$ mA			-1.2	V
V_{OH}	$V_{CC} = 4.75$ V,	$I_{OH} = -48$ mA	2			V
V_{OL}	$V_{CC} = 4.75$ V,	$I_{OL} = 48$ mA			0.5	V
I_{IH}	$V_{CC} = 5.25$ V,	$V_I = 2.7$ V			50	μA
I_{IL}	$V_{CC} = 5.25$ V,	$V_I = 0.5$ V			-50	μA
I_{OZ}	$V_{CC} = 5.25$ V,	$V_O = 2.7$ V or 0.5 V			±50	μA
$I_{O‡}$	$V_{CC} = 5.25$ V,	$V_O = 2.5$ V	-50		-180	mA
I_{CC}	$V_{CC} = 5.25$ V, $V_I = V_{CC}$ or GND	$I_O = 0$,	Outputs high		70	mA
			Outputs low		85	
			Outputs disabled		70	
C_i	$V_I = 2.5$ V or 0.5 V				3	pF
C_o	$V_O = 2.5$ V or 0.5 V				8	pF

† All typical values are at $V_{CC} = 5$ V, $T_A = 25$ °C.

‡ Not more than one output should be tested at a time, and the duration of the test should not exceed one second.

timing requirements over recommended ranges of supply voltage and operating free-air temperature

		MIN	MAX	UNIT
f_{clock}	Clock frequency		80	MHz
t_w	Pulse duration	\overline{CLR} low	4	ns
		CLK low	4	
		CLK high	4	
t_{su}	Setup time		2	ns
	Clock duty cycle	40%	60%	

CDC339
CLOCK DRIVER
WITH 3-STATE OUTPUTS

SCAS331 – DECEMBER 1992 – REVISED MARCH 1994

switching characteristics over recommended ranges of supply voltage and operating free-air temperature (see Figures 1 and 2)

PARAMETER	FROM (INPUT)	TO (OUTPUT)	MIN	TYP†	MAX	UNIT
f_{max}			80			MHz
t_{PLH}	CLK	Any Y or Q	3		9	ns
t_{PHL}			3		9	
t_{PHL}	\overline{CLR}	Any Q	4		9	ns
t_{PZH}	\overline{OE}	Any Y or Q	2		7	ns
t_{PZL}			3		7	
t_{PHZ}	\overline{OE}	Any Y or Q	2		7	ns
t_{PLZ}			2		7	
$t_{sk(o)}$	CLK↑	Y↑			0.75	ns
		Q↑			0.9	
		Y↑ and Q↑			0.9	
t_r				0.9		ns
t_f				0.7		ns

† All typical values are at $V_{CC} = 5\text{ V}$, $T_A = 25^\circ\text{C}$.

PARAMETER MEASUREMENT INFORMATION

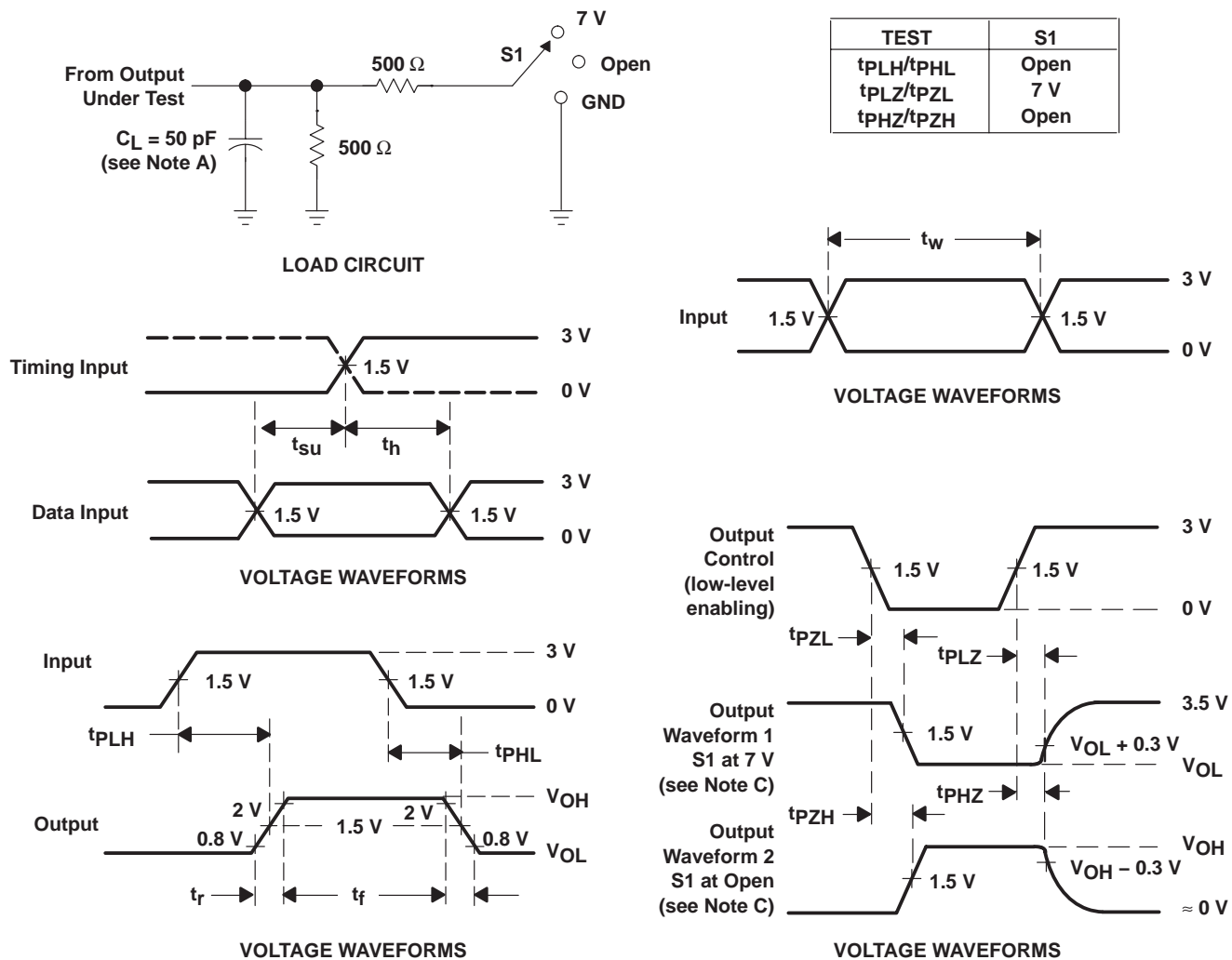

- NOTES: A. C_L includes probe and jig capacitance.
 B. All input pulses are supplied by generators having the following characteristics: $PRR \leq 10 \text{ MHz}$, $Z_O = 50 \Omega$, $t_r \leq 2.5 \text{ ns}$, $t_f \leq 2.5 \text{ ns}$.
 C. Waveform 1 is for an output with internal conditions such that the output is low except when disabled by the output control. Waveform 2 is for an output with internal conditions such that the output is high except when disabled by the output control.
 D. The outputs are measured one at a time with one transition per measurement.

Figure 1. Load Circuit and Voltage Waveforms

**CDC339
CLOCK DRIVER
WITH 3-STATE OUTPUTS**

SCAS331 – DECEMBER 1992 – REVISED MARCH 1994

PARAMETER MEASUREMENT INFORMATION

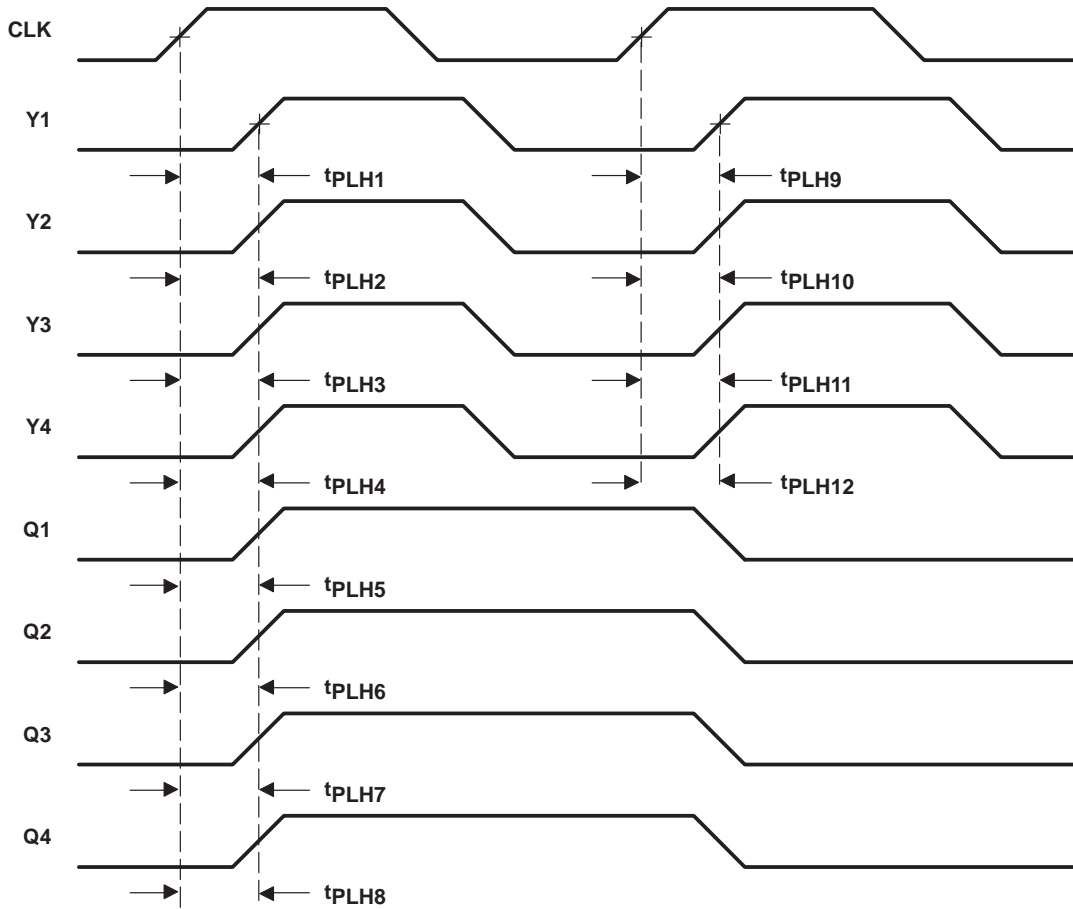

- NOTES: A. Output skew, $t_{sk(o)}$, from $CLK\uparrow$ to $Y\uparrow$, is calculated as the greater of the difference between the fastest and slowest of t_{PLHn} ($n = 1, 2, 3, 4$) or t_{PLHn} ($n = 9, 10, 11, 12$).
- B. Output skew, $t_{sk(o)}$, from $CLK\uparrow$ to $Q\uparrow$, is calculated as the greater of the difference between the fastest and slowest of t_{PLHn} ($n = 5, 6, 7, 8$).
- C. Output skew, $t_{sk(o)}$, from $CLK\uparrow$ to $Y\uparrow$ and $Q\uparrow$, is calculated as the greater of the difference between the fastest and slowest of t_{PLHn} ($n = 1, 2, \dots, 8$).

Figure 2. Skew Waveforms and Calculations

PACKAGING INFORMATION

Orderable Device	Status (1)	Package Type	Package Drawing	Pins	Package Qty	Eco Plan (2)	Lead/Ball Finish	MSL Peak Temp (3)	Op Temp (°C)	Top-Side Markings (4)	Samples
CDC339DB	ACTIVE	SSOP	DB	20	70	Green (RoHS & no Sb/Br)	CU NIPDAU	Level-1-260C-UNLIM		CK339	Samples
CDC339DBG4	ACTIVE	SSOP	DB	20	70	Green (RoHS & no Sb/Br)	CU NIPDAU	Level-1-260C-UNLIM		CK339	Samples
CDC339DBLE	OBSOLETE	SSOP	DB	20		TBD	Call TI	Call TI			
CDC339DW	ACTIVE	SOIC	DW	20	25	Green (RoHS & no Sb/Br)	CU NIPDAU	Level-1-260C-UNLIM		CDC339	Samples
CDC339DWG4	ACTIVE	SOIC	DW	20	25	Green (RoHS & no Sb/Br)	CU NIPDAU	Level-1-260C-UNLIM		CDC339	Samples
CDC339NSR	OBSOLETE	SO	NS	20		TBD	Call TI	Call TI			
CDC339NSRG4	OBSOLETE	SO	NS	20		TBD	Call TI	Call TI			

(1) The marketing status values are defined as follows:

ACTIVE: Product device recommended for new designs.

LIFEBUY: TI has announced that the device will be discontinued, and a lifetime-buy period is in effect.

NRND: Not recommended for new designs. Device is in production to support existing customers, but TI does not recommend using this part in a new design.

PREVIEW: Device has been announced but is not in production. Samples may or may not be available.

OBSOLETE: TI has discontinued the production of the device.

(2) Eco Plan - The planned eco-friendly classification: Pb-Free (RoHS), Pb-Free (RoHS Exempt), or Green (RoHS & no Sb/Br) - please check <http://www.ti.com/productcontent> for the latest availability information and additional product content details.

TBD: The Pb-Free/Green conversion plan has not been defined.

Pb-Free (RoHS): TI's terms "Lead-Free" or "Pb-Free" mean semiconductor products that are compatible with the current RoHS requirements for all 6 substances, including the requirement that lead not exceed 0.1% by weight in homogeneous materials. Where designed to be soldered at high temperatures, TI Pb-Free products are suitable for use in specified lead-free processes.

Pb-Free (RoHS Exempt): This component has a RoHS exemption for either 1) lead-based flip-chip solder bumps used between the die and package, or 2) lead-based die adhesive used between the die and leadframe. The component is otherwise considered Pb-Free (RoHS compatible) as defined above.

Green (RoHS & no Sb/Br): TI defines "Green" to mean Pb-Free (RoHS compatible), and free of Bromine (Br) and Antimony (Sb) based flame retardants (Br or Sb do not exceed 0.1% by weight in homogeneous material)

(3) MSL, Peak Temp. -- The Moisture Sensitivity Level rating according to the JEDEC industry standard classifications, and peak solder temperature.

(4) Only one of markings shown within the brackets will appear on the physical device.

Important Information and Disclaimer: The information provided on this page represents TI's knowledge and belief as of the date that it is provided. TI bases its knowledge and belief on information provided by third parties, and makes no representation or warranty as to the accuracy of such information. Efforts are underway to better integrate information from third parties. TI has taken and

continues to take reasonable steps to provide representative and accurate information but may not have conducted destructive testing or chemical analysis on incoming materials and chemicals. TI and TI suppliers consider certain information to be proprietary, and thus CAS numbers and other limited information may not be available for release.

In no event shall TI's liability arising out of such information exceed the total purchase price of the TI part(s) at issue in this document sold by TI to Customer on an annual basis.

DW (R-PDSO-G20)

PLASTIC SMALL OUTLINE

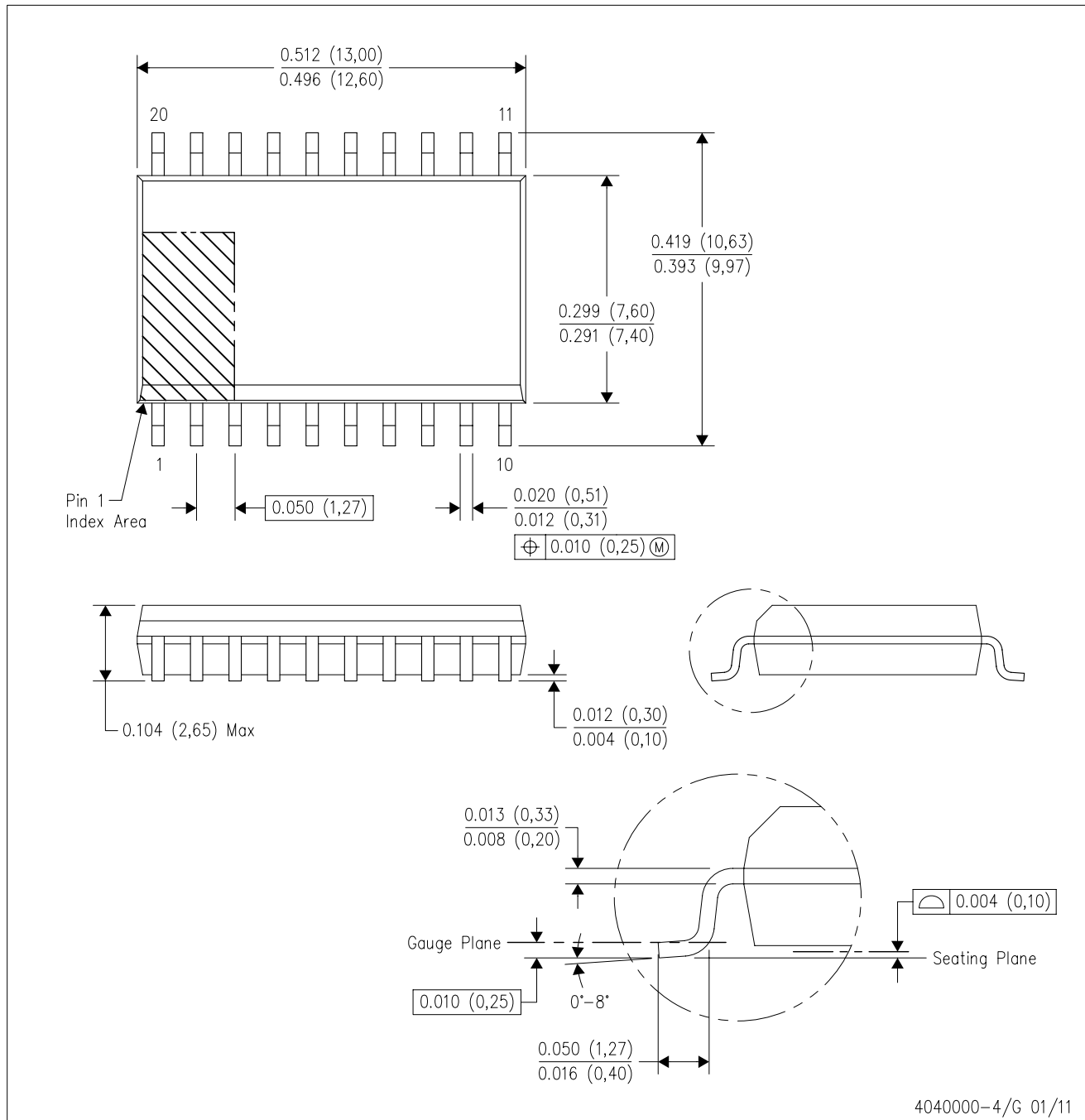

- NOTES:
- All linear dimensions are in inches (millimeters). Dimensioning and tolerancing per ASME Y14.5M-1994.
 - This drawing is subject to change without notice.
 - Body dimensions do not include mold flash or protrusion not to exceed 0.006 (0,15).
 - Falls within JEDEC MS-013 variation AC.

DW (R-PDSO-G20)

PLASTIC SMALL OUTLINE

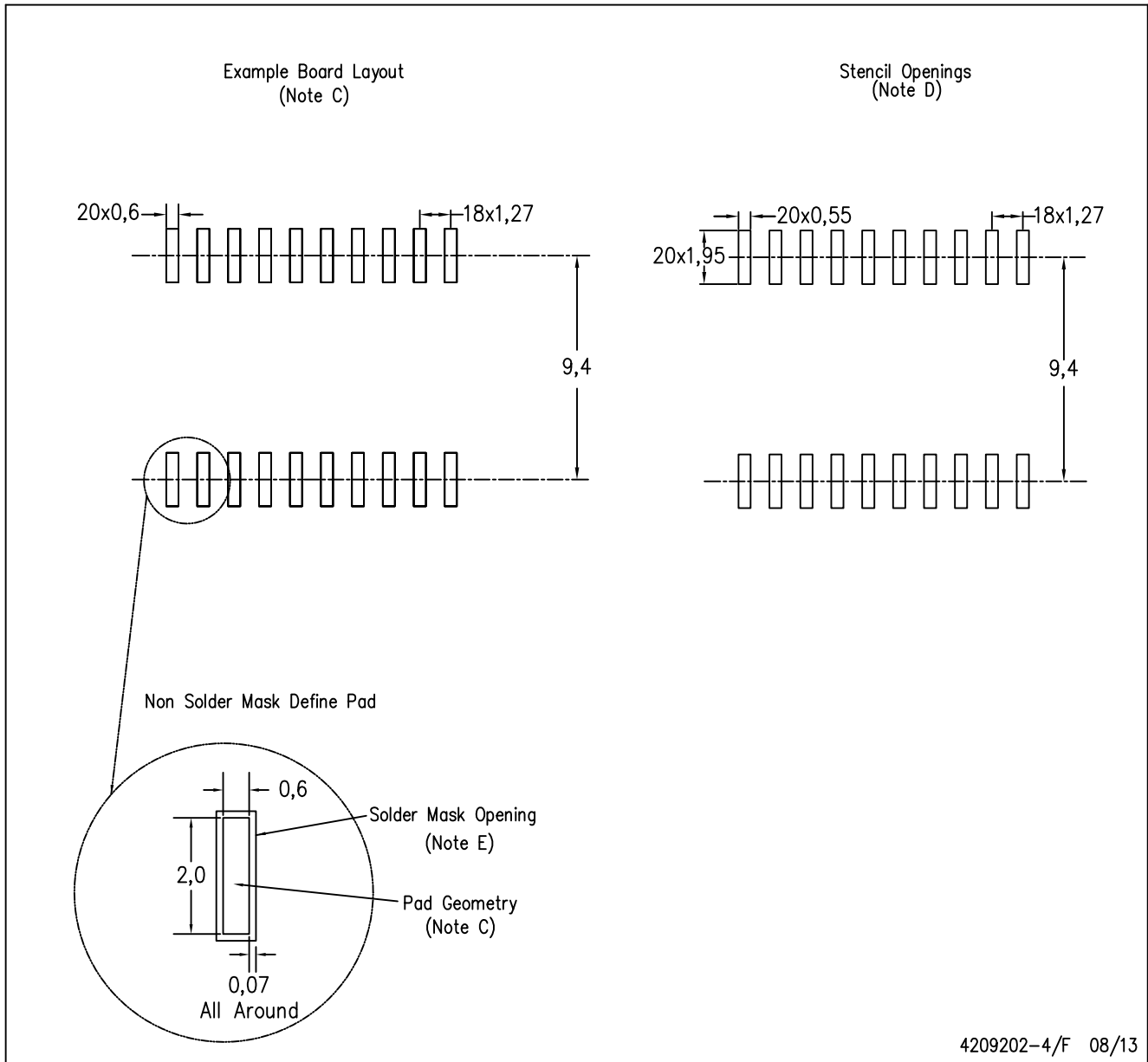

4209202-4/F 08/13

- NOTES:
- A. All linear dimensions are in millimeters.
 - B. This drawing is subject to change without notice.
 - C. Refer to IPC7351 for alternate board design.
 - D. Laser cutting apertures with trapezoidal walls and also rounding corners will offer better paste release. Customers should contact their board assembly site for stencil design recommendations. Refer to IPC-7525
 - E. Customers should contact their board fabrication site for solder mask tolerances between and around signal pads.

DB (R-PDSO-G**)

PLASTIC SMALL-OUTLINE

28 PINS SHOWN



4040065 /E 12/01

- NOTES: A. All linear dimensions are in millimeters.
 B. This drawing is subject to change without notice.
 C. Body dimensions do not include mold flash or protrusion not to exceed 0,15.
 D. Falls within JEDEC MO-150

MECHANICAL DATA

NS (R-PDSO-G**)

PLASTIC SMALL-OUTLINE PACKAGE

14-PINS SHOWN



- NOTES:
- A. All linear dimensions are in millimeters.
 - B. This drawing is subject to change without notice.
 - C. Body dimensions do not include mold flash or protrusion, not to exceed 0,15.

IMPORTANT NOTICE

Texas Instruments Incorporated and its subsidiaries (TI) reserve the right to make corrections, enhancements, improvements and other changes to its semiconductor products and services per JESD46, latest issue, and to discontinue any product or service per JESD48, latest issue. Buyers should obtain the latest relevant information before placing orders and should verify that such information is current and complete. All semiconductor products (also referred to herein as "components") are sold subject to TI's terms and conditions of sale supplied at the time of order acknowledgment.

TI warrants performance of its components to the specifications applicable at the time of sale, in accordance with the warranty in TI's terms and conditions of sale of semiconductor products. Testing and other quality control techniques are used to the extent TI deems necessary to support this warranty. Except where mandated by applicable law, testing of all parameters of each component is not necessarily performed.

TI assumes no liability for applications assistance or the design of Buyers' products. Buyers are responsible for their products and applications using TI components. To minimize the risks associated with Buyers' products and applications, Buyers should provide adequate design and operating safeguards.

TI does not warrant or represent that any license, either express or implied, is granted under any patent right, copyright, mask work right, or other intellectual property right relating to any combination, machine, or process in which TI components or services are used. Information published by TI regarding third-party products or services does not constitute a license to use such products or services or a warranty or endorsement thereof. Use of such information may require a license from a third party under the patents or other intellectual property of the third party, or a license from TI under the patents or other intellectual property of TI.

Reproduction of significant portions of TI information in TI data books or data sheets is permissible only if reproduction is without alteration and is accompanied by all associated warranties, conditions, limitations, and notices. TI is not responsible or liable for such altered documentation. Information of third parties may be subject to additional restrictions.

Resale of TI components or services with statements different from or beyond the parameters stated by TI for that component or service voids all express and any implied warranties for the associated TI component or service and is an unfair and deceptive business practice. TI is not responsible or liable for any such statements.

Buyer acknowledges and agrees that it is solely responsible for compliance with all legal, regulatory and safety-related requirements concerning its products, and any use of TI components in its applications, notwithstanding any applications-related information or support that may be provided by TI. Buyer represents and agrees that it has all the necessary expertise to create and implement safeguards which anticipate dangerous consequences of failures, monitor failures and their consequences, lessen the likelihood of failures that might cause harm and take appropriate remedial actions. Buyer will fully indemnify TI and its representatives against any damages arising out of the use of any TI components in safety-critical applications.

In some cases, TI components may be promoted specifically to facilitate safety-related applications. With such components, TI's goal is to help enable customers to design and create their own end-product solutions that meet applicable functional safety standards and requirements. Nonetheless, such components are subject to these terms.

No TI components are authorized for use in FDA Class III (or similar life-critical medical equipment) unless authorized officers of the parties have executed a special agreement specifically governing such use.

Only those TI components which TI has specifically designated as military grade or "enhanced plastic" are designed and intended for use in military/aerospace applications or environments. Buyer acknowledges and agrees that any military or aerospace use of TI components which have **not** been so designated is solely at the Buyer's risk, and that Buyer is solely responsible for compliance with all legal and regulatory requirements in connection with such use.

TI has specifically designated certain components as meeting ISO/TS16949 requirements, mainly for automotive use. In any case of use of non-designated products, TI will not be responsible for any failure to meet ISO/TS16949.

Products

Audio	www.ti.com/audio
Amplifiers	amplifier.ti.com
Data Converters	dataconverter.ti.com
DLP® Products	www.dlp.com
DSP	dsp.ti.com
Clocks and Timers	www.ti.com/clocks
Interface	interface.ti.com
Logic	logic.ti.com
Power Mgmt	power.ti.com
Microcontrollers	microcontroller.ti.com
RFID	www.ti-rfid.com
OMAP Applications Processors	www.ti.com/omap
Wireless Connectivity	www.ti.com/wirelessconnectivity

Applications

Automotive and Transportation	www.ti.com/automotive
Communications and Telecom	www.ti.com/communications
Computers and Peripherals	www.ti.com/computers
Consumer Electronics	www.ti.com/consumer-apps
Energy and Lighting	www.ti.com/energy
Industrial	www.ti.com/industrial
Medical	www.ti.com/medical
Security	www.ti.com/security
Space, Avionics and Defense	www.ti.com/space-avionics-defense
Video and Imaging	www.ti.com/video

TI E2E Community

e2e.ti.com