

CDCVF2310 2.5-V to 3.3-V High-Performance Clock Buffer

1 Features

- High-Performance 1:10 Clock Driver
- Operates up to 200 MHz at V_{DD} 3.3 V
- Pin-to-Pin Skew < 100 ps at V_{DD} 3.3 V
- V_{DD} Range: 2.3 V to 3.6 V
- Operating Temperature Range -40°C to 105°C
- Supports 105°C Ambient Temperature (see [Thermal Considerations](#))
- Output Enable Glitch Suppression
- Distributes One Clock Input to Two Banks of Five Outputs
- 25- Ω On-Chip Series Damping Resistors
- Packaged in 24-Pin TSSOP

2 Applications

- General-Purpose Applications

3 Description

The CDCVF2310 device is a high-performance, low-skew clock buffer that operates up to 200 MHz. Two banks of five outputs each provide low-skew copies of CLK. After power up, the default state of the outputs is low regardless of the state of the control pins. For normal operation, the outputs of bank 1Y[0:4] or 2Y[0:4] can be placed in a low state when the control pins (1G or 2G, respectively) are held low and a negative clock edge is detected on the CLK input. The outputs of bank 1Y[0:4] or 2Y[0:4] can be switched into the buffer mode when the control pins (1G and 2G) are held high and a negative clock edge is detected on the CLK input. The device operates in a 2.5-V and 3.3-V environment. The built-in output enable glitch suppression ensures a synchronized output enable sequence to distribute full period clock signals.

The CDCVF2310 is characterized for operation from -40°C to 85°C .

Device Information (1)

PART NUMBER	PACKAGE	BODY SIZE (NOM)
CDCVF2310	TSSOP (24)	4.40 mm x 7.80 mm

(1) For all available packages, see the orderable addendum at the end of the data sheet.

Functional Block Diagram

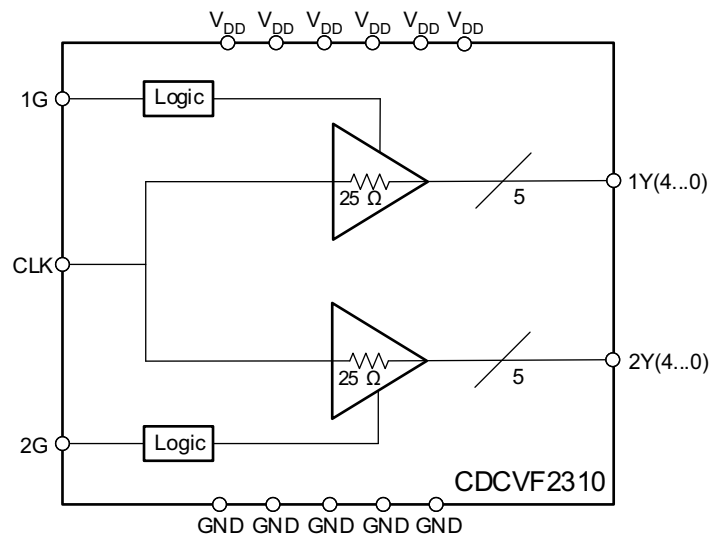

Table of Contents

1 Features	1	8.2 Functional Block Diagram	9
2 Applications	1	8.3 Feature Description	10
3 Description	1	8.4 Device Functional Modes	11
4 Revision History	2	9 Application and Implementation	12
5 Pin Configuration and Functions	3	9.1 Application Information	12
6 Specifications	3	9.2 Typical Application	12
6.1 Absolute Maximum Ratings	3	10 Power Supply Recommendations	14
6.2 ESD Ratings	4	11 Layout	15
6.3 Recommended Operating Conditions	4	11.1 Layout Guidelines	15
6.4 Thermal Information	4	11.2 Layout Example	15
6.5 Electrical Characteristics	4	11.3 Thermal Considerations	15
6.6 Timing Requirements	5	12 Device and Documentation Support	16
6.7 Jitter Characteristics	5	12.1 Documentation Support	16
6.8 Switching Characteristics	6	12.2 Community Resources	16
6.9 Switching Characteristics	6	12.3 Trademarks	16
6.10 Typical Characteristics	7	12.4 Electrostatic Discharge Caution	16
7 Parameter Measurement Information	8	12.5 Glossary	16
8 Detailed Description	9	13 Mechanical, Packaging, and Orderable Information	16
8.1 Overview	9		

4 Revision History

NOTE: Page numbers for previous revisions may differ from page numbers in the current version.

Changes from Revision C (January 2008) to Revision D	Page
<ul style="list-style-type: none"> Added <i>ESD Ratings</i> table, <i>Feature Description</i> section, <i>Device Functional Modes</i>, <i>Application and Implementation</i> section, <i>Power Supply Recommendations</i> section, <i>Layout</i> section, <i>Device and Documentation Support</i> section, and <i>Mechanical, Packaging, and Orderable Information</i> section. 	1

5 Pin Configuration and Functions

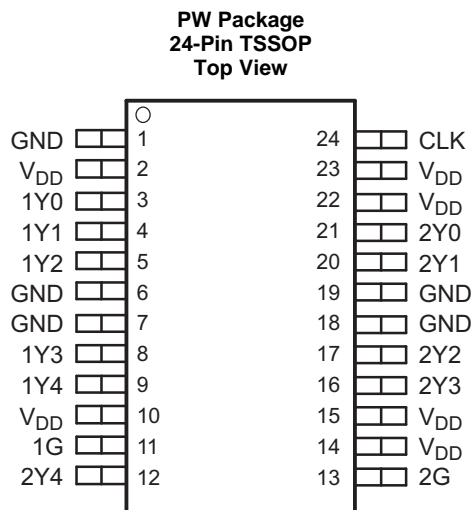

Pin Functions

PIN		I/O	DESCRIPTION
NAME	NO.		
1G	11	I	Output enable control for 1Y[0:4] outputs. This output enable is active-high, meaning the 1Y[0:4] clock outputs follow the input clock (CLK) if this pin is logic high.
2G	13	I	Output enable control for 2Y[0:4] outputs. This output enable is active-high, meaning the 2Y[0:4] clock outputs follow the input clock (CLK) if this pin is logic high.
1Y[0:4]	3, 4, 5, 8, 9	O	Buffered output clocks
2Y[0:4]	21, 20, 17, 16, 12	O	Buffered output clocks
CLK	24	I	Input reference frequency
GND	1, 6, 7, 18, 19	—	Ground
V _{DD}	2, 10, 14, 15, 22, 23	—	DC power supply, 2.3 V – 3.6 V

6 Specifications

6.1 Absolute Maximum Ratings

over operating free-air temperature range (unless otherwise noted)⁽¹⁾

			MIN	MAX	UNIT
V _{DD}	Supply voltage		-0.5	4.6	V
V _I ^{(2) (3)}	Input voltage		-0.5	V _{DD} + 0.5	V
V _O ^{(2) (3)}	Output voltage		-0.5	V _{DD} + 0.5	V
I _{IK}	Input clamp current	V _I < 0 or V _I > V _{DD}		±50	mA
I _{OK}	Output clamp current	V _O < 0 or V _O > V _{DD}		±50	mA
I _O	Continuous total output current	V _O = 0 to V _{DD}		±50	mA
T _J	Maximum junction temperature			125	°C
T _{stg}	Storage temperature		-65	150	°C

- (1) Stresses beyond those listed under *Absolute Maximum Ratings* may cause permanent damage to the device. These are stress ratings only, which do not imply functional operation of the device at these or any other conditions beyond those indicated under *Recommended Operating Conditions*. Exposure to absolute-maximum-rated conditions for extended periods may affect device reliability.
- (2) The input and output negative voltage ratings may be exceeded if the input and output clamp-current ratings are observed.
- (3) This value is limited to 4.6 V maximum.

CDCVF2310

SCAS666D – JUNE 2001 – REVISED OCTOBER 2015

www.ti.com

6.2 ESD Ratings

		VALUE	UNIT
$V_{(ESD)}$	Electrostatic discharge	Human body model (HBM), per ANSI/ESDA/JEDEC JS-001 ⁽¹⁾	2000
		Charged-device model (CDM), per JEDEC specification JESD22-C101 ⁽²⁾	1000

(1) JEDEC document JEP155 states that 500-V HBM allows safe manufacturing with a standard ESD control process.

(2) JEDEC document JEP157 states that 250-V CDM allows safe manufacturing with a standard ESD control process.

6.3 Recommended Operating Conditions

See ⁽¹⁾

		MIN	NOM	MAX	UNIT
V_{DD}	Supply voltage	2.3	2.5		V
			3.3	3.6	
V_{IL}	Low-level input voltage	$V_{DD} = 3\text{ V to }3.6\text{ V}$		0.8	V
		$V_{DD} = 2.3\text{ V to }2.7\text{ V}$		0.7	
V_{IH}	High-level input voltage	$V_{DD} = 3\text{ V to }3.6\text{ V}$		2	V
		$V_{DD} = 2.3\text{ V to }2.7\text{ V}$		1.7	
V_I	Input voltage	0		V_{DD}	V
I_{OH}	High-level output current	$V_{DD} = 3\text{ V to }3.6\text{ V}$		12	mA
		$V_{DD} = 2.3\text{ V to }2.7\text{ V}$		6	
I_{OL}	Low-level output current	$V_{DD} = 3\text{ V to }3.6\text{ V}$		12	mA
		$V_{DD} = 2.3\text{ V to }2.7\text{ V}$		6	
T_A	Operating free-air temperature	-40		85	°C

(1) Unused inputs must be held high or low to prevent them from floating.

6.4 Thermal Information

THERMAL METRIC ⁽¹⁾		CDCVF2310	UNIT
		PW (TSSOP)	
		24 PINS	
$R_{\theta JA}$	Junction-to-ambient thermal resistance	91.7	°C/W
$R_{\theta JC(top)}$	Junction-to-case (top) thermal resistance	31.2	°C/W
$R_{\theta JB}$	Junction-to-board thermal resistance	46.4	°C/W
Ψ_{JT}	Junction-to-top characterization parameter	1.5	°C/W
Ψ_{JB}	Junction-to-board characterization parameter	45.8	°C/W
$R_{\theta JC(bot)}$	Junction-to-case (bottom) thermal resistance	n/a	°C/W

(1) For more information about traditional and new thermal metrics, see the *Semiconductor and IC Package Thermal Metrics* application report, [SPRA953](#).

6.5 Electrical Characteristics

over recommended operating free-air temperature range (unless otherwise noted)

PARAMETER		TEST CONDITIONS		MIN	TYP ⁽¹⁾	MAX	UNIT
V_{IK}	Input voltage	$V_{DD} = 3\text{ V}$	$I_I = -18\text{ mA}$			-1.2	V
I_I	Input current	$V_I = 0\text{ V or }V_{DD}$				±5	µA
I_{DD}	Static device current	CLK = 0 V or V_{DD} , $I_O = 0\text{ mA}$	-40°C to 85°C			80	µA
			≤105°C			100	µA
C_I	Input capacitance	$V_{DD} = 2.3\text{ V to }3.6\text{ V}$	$V_I = 0\text{ V or }V_{DD}$		2.5		pF
C_O	Output capacitance	$V_{DD} = 2.3\text{ V to }3.6\text{ V}$	$V_I = 0\text{ V or }V_{DD}$		2.8		pF

(1) All typical values are at respective nominal V_{DD} .

Electrical Characteristics (continued)

over recommended operating free-air temperature range (unless otherwise noted)

PARAMETER		TEST CONDITIONS		MIN	TYP ⁽¹⁾	MAX	UNIT
V_{DD} = 3.3 V ±0.3 V							
V _{OH}	High-level output voltage	V _{DD} = min to max	I _{OH} = -100 μA	V _{DD} - 0.2			V
		V _{DD} = 3 V	I _{OH} = -12 mA I _{OH} = -6 mA	2.1	2.4		
V _{OL}	Low-level output voltage	V _{DD} = min to max	I _{OL} = -100 μA			0.2	V
		V _{DD} = 3 V	I _{OL} = 12 mA I _{OL} = 6 mA			0.8 0.55	
I _{OH}	High-level output current	V _{DD} = 3 V	V _O = 1 V	-28			mA
		V _{DD} = 3.3 V	V _O = 1.65 V			-36	
		V _{DD} = 3.6 V	V _O = 3.135 V			-14	
I _{OL}	Low-level output current	V _{DD} = 3 V	V _O = 1.95 V	28			mA
		V _{DD} = 3.3 V	V _O = 1.65 V			36	
		V _{DD} = 3.6 V	V _O = 0.4 V			14	
V_{DD} = 2.5 V ±0.2 V							
V _{OH}	High-level output voltage	V _{DD} = min to max	I _{OH} = -100 μA	V _{DD} - 0.2			V
		V _{DD} = 2.3 V	I _{OH} = -6 mA	1.8			
V _{OL}	Low-level output voltage	V _{DD} = min to max	I _{OL} = 100 μA			0.2	V
		V _{DD} = 2.3 V	I _{OL} = 6 mA			0.55	
I _{OH}	High-level output current	V _{DD} = 2.3 V	V _O = 1 V	-17			mA
		V _{DD} = 2.5 V	V _O = 1.25 V			-25	
		V _{DD} = 2.7 V	V _O = 2.375 V			-10	
I _{OL}	Low-level output current	V _{DD} = 2.3 V	V _O = 1.2 V	17			mA
		V _{DD} = 2.5 V	V _O = 1.25 V			25	
		V _{DD} = 2.7 V	V _O = 0.3 V			10	

6.6 Timing Requirements

over recommended ranges of supply voltage and operating free-air temperature

		MIN	MAX	UNIT	
f _{clk}	Clock frequency	V _{DD} = 3 V to 3.6 V	0	200	MHz
		V _{DD} = 2.3 V to 2.7 V	0	170	

6.7 Jitter Characteristics

 Characterized using CDCVF2310 Performance EVM when V_{DD} = 3.3 V. Outputs not under test are terminated to 50 Ω.

PARAMETER		TEST CONDITIONS		TYP	UNIT
t _{jitter}	Additive phase jitter from input to output 1Y0	12 kHz to 5 MHz, f _{out} = 30.72 MHz		52	fs rms
		12 kHz to 20 MHz, f _{out} = 125 MHz		45	

6.8 Switching Characteristics

 $V_{DD} = 3.3V \pm 0.3V$ (see [Figure 2](#)) and over recommended operating free-air temperature range (unless otherwise noted)

PARAMETER		TEST CONDITIONS	MIN	MAX	UNIT
t_{PLH}	CLK to Yn	f = 0 MHz to 200 MHz For circuit load, see Figure 2 .	1.3	2.8	ns
t_{PHL}					
$t_{sk(o)}$	Output skew (Ym to Yn) ⁽¹⁾ (see Figure 4)			100	ps
$t_{sk(p)}$	Pulse skew (see Figure 5)			250	ps
$t_{sk(pp)}$	Part-to-part skew			500	ps
t_r	Rise time (see Figure 3)	$V_O = 0.4 V$ to 2 V	0.7	2	V/ns
t_f	Fall time (see Figure 3)	$V_O = 2 V$ to 0.4 V	0.7	2	V/ns
$t_{su(en)}$	Enable setup time, G_high before CLK ↓		0.1		ns
$t_{su(dis)}$	Disable setup time, G_low before CLK ↓		0.1		ns
$t_{h(en)}$	Enable hold time, G_high after CLK ↓		0.4		ns
$t_{h(dis)}$	Disable hold time, G_low after CLK ↓		0.4		ns

(1) The $t_{sk(o)}$ specification is only valid for equal loading of all outputs.

6.9 Switching Characteristics

 $V_{DD} = 2.5V \pm 0.2V$ (see [Figure 2](#)) and over recommended operating free-air temperature range (unless otherwise noted)

PARAMETER		TEST CONDITIONS	MIN	MAX	UNIT
t_{PLH}	CLK to Yn	f = 0 MHz to 170 MHz For circuit load, see Figure 2 .	1.5	3.5	ns
t_{PHL}					
$t_{sk(o)}$	Output skew (Ym to Yn) ⁽¹⁾ (see Figure 4)			170	ps
$t_{sk(p)}$	Pulse skew (see Figure 5)			400	ps
$t_{sk(pp)}$	Part-to-part skew			600	ps
t_r	Rise time (see Figure 3)	$V_O = 0.4 V$ to 1.7 V	0.5	1.4	V/ns
t_f	Fall time (see Figure 3)	$V_O = 1.7 V$ to 0.4 V	0.5	1.4	V/ns
$t_{su(en)}$	Enable setup time, G_high before CLK ↓		0.1		ns
$t_{su(dis)}$	Disable setup time, G_low before CLK ↓		0.1		ns
$t_{h(en)}$	Enable hold time, G_high after CLK ↓		0.4		ns
$t_{h(dis)}$	Disable hold time, G_low after CLK ↓		0.4		ns

(1) The $t_{sk(o)}$ specification is only valid for equal loading of all outputs.

6.10 Typical Characteristics

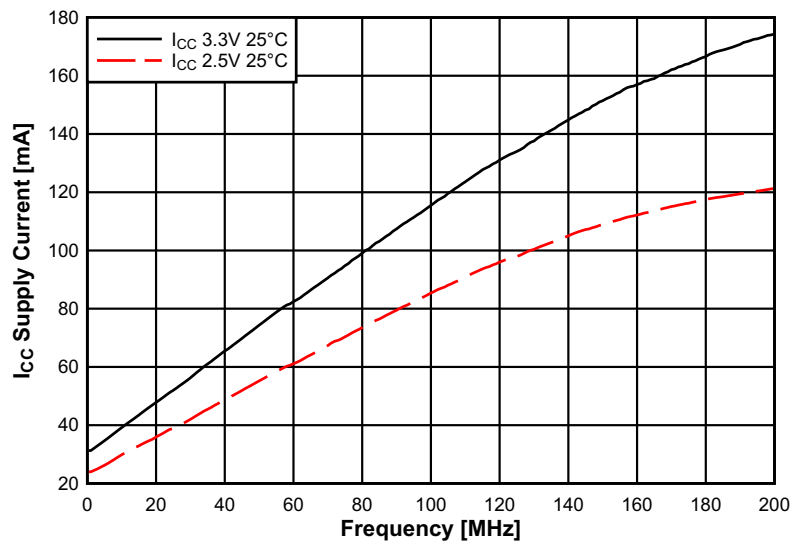
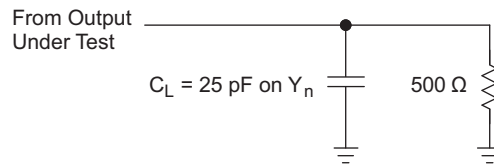

Figure 1. Supply Current vs Frequency

7 Parameter Measurement Information



- A. C_L includes probe and jig capacitance.
- B. All input pulses are supplied by generators having the following characteristics: $PRR \leq 200$ MHz, $Z_O = 50 \Omega$, $t_r < 1.2$ ns, $t_f < 1.2$ ns.

Figure 2. Test Load Circuit

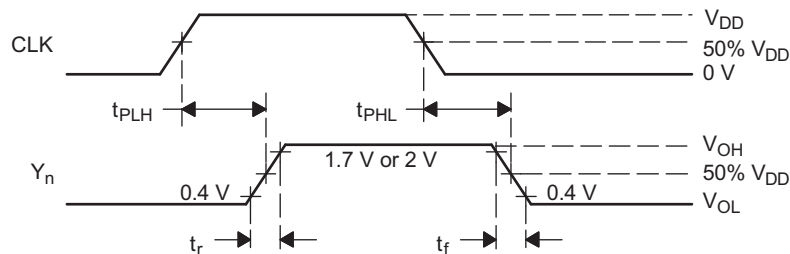

Figure 3. Voltage Waveforms Propagation Delay Times

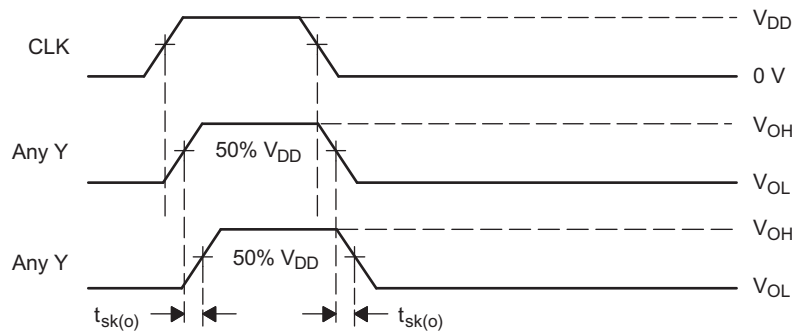
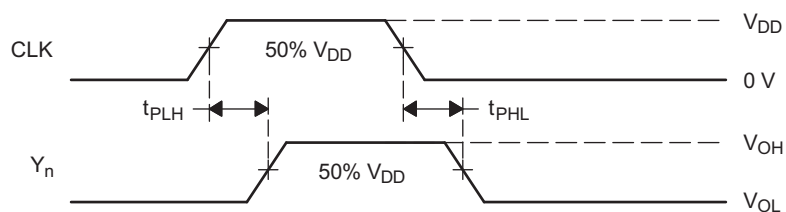

Figure 4. Output Skew



NOTE: $t_{sk(p)} = |t_{PLH} - t_{PHL}|$

Figure 5. Pulse Skew

8 Detailed Description

8.1 Overview

The CDCVF2310 is a high-performance, low-skew clock buffer that operates up to 200 MHz. Two banks of five outputs each provide low-skew copies of CLK. After power up, the default state of the outputs is low regardless of the state of the control pins. For normal operation, the outputs of bank 1Y[0:4] or 2Y[0:4] can be placed in a low state when the control pins (1G or 2G, respectively) are held low and a negative clock edge is detected on the CLK input. The outputs of bank 1Y[0:4] or 2Y[0:4] can be switched into the buffer mode when the control pins (1G and 2G) are held high and a negative clock edge is detected on the CLK input. The device operates in a 2.5-V and 3.3-V environment. The built-in output enable glitch suppression ensures a synchronized output enable sequence to distribute full period clock signals.

8.2 Functional Block Diagram

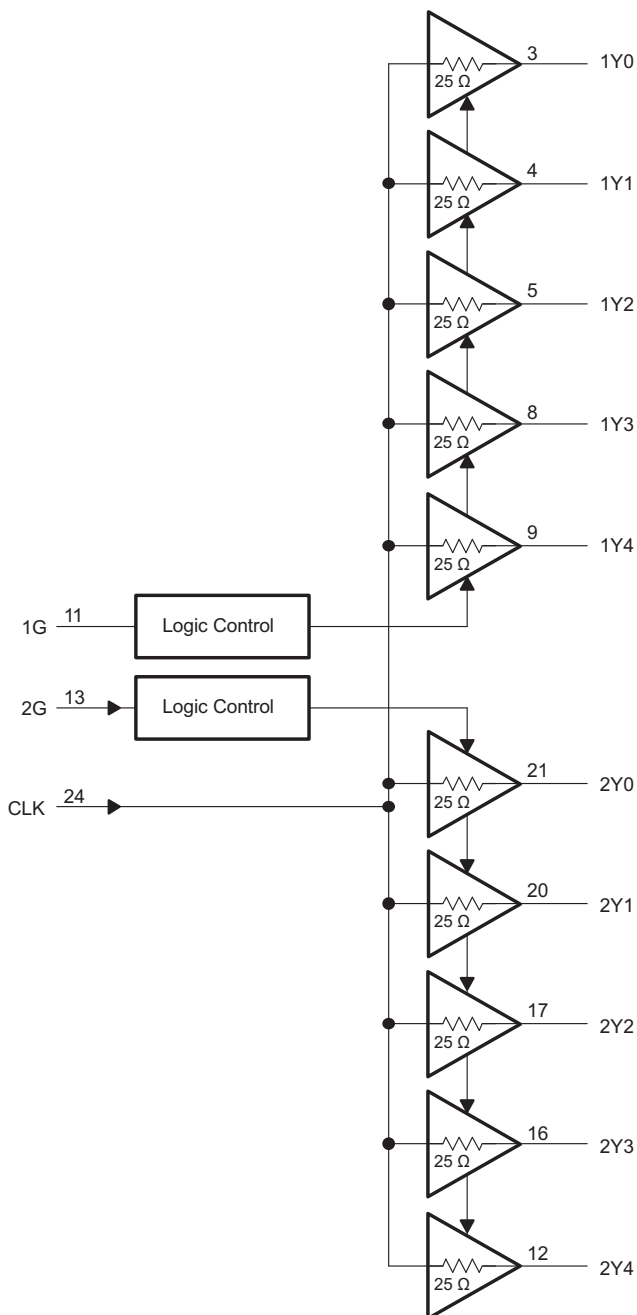

8.3 Feature Description

8.3.1 Output Enable Glitch Suppression Circuit

The purpose of the glitch suppression circuitry is to ensure the output enable sequence is synchronized with the clock input such that the output buffer is enabled or disabled on the next full period of the input clock (negative edge triggered by the input clock) (see [Figure 6](#)).

The G input must fulfill the timing requirements (t_{su} , t_h) according to the [Switching Characteristics](#) table for predictable operation.

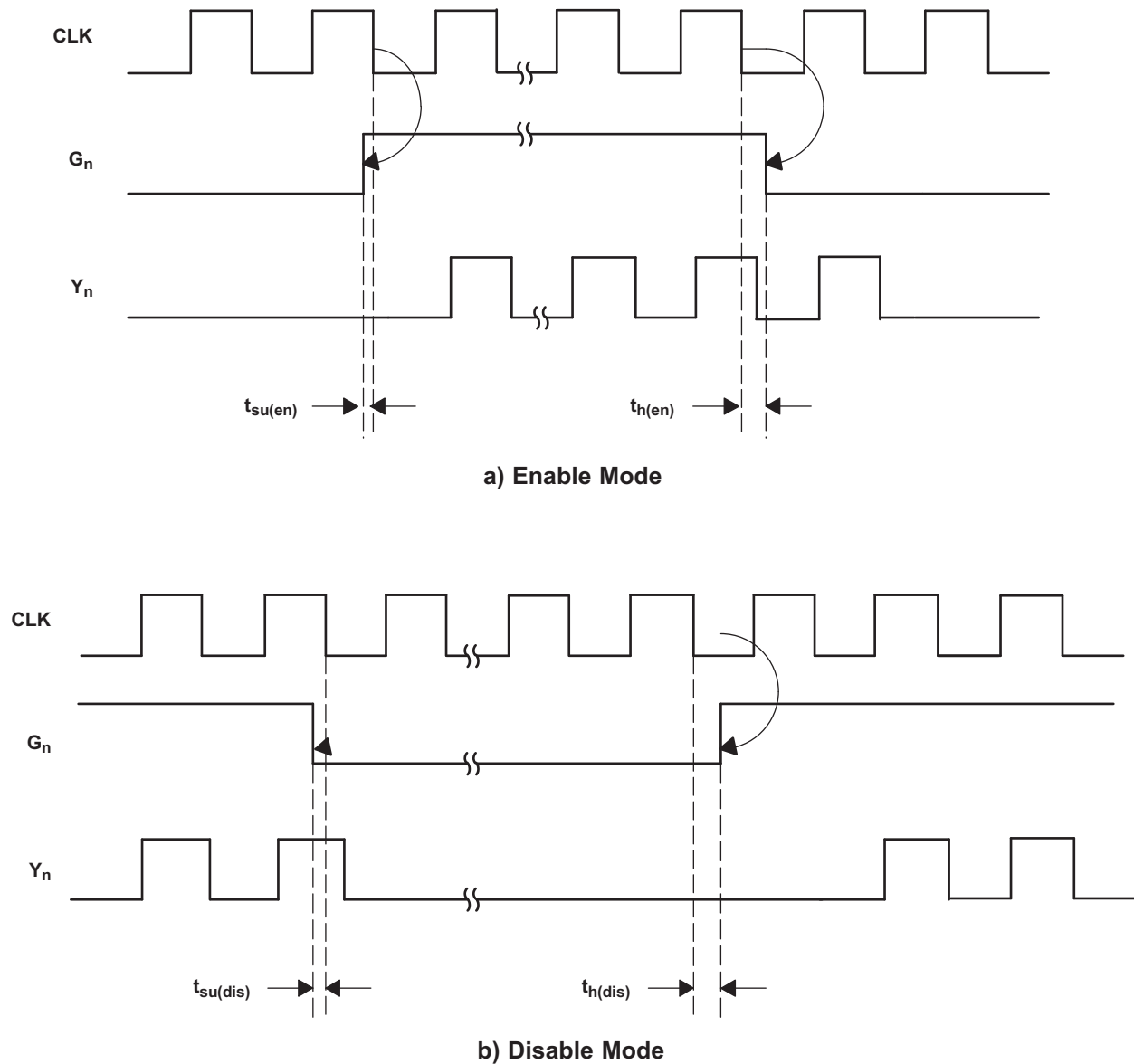

Figure 6. Enable and Disable Mode Relative to CLK↓

8.4 Device Functional Modes

Table 1 lists the functional modes for the CDCVF2310.

Table 1. Function Table

INPUT			OUTPUT	
1G	2G	CLK	1Y[0:4]	2Y[0:4]
L	L	↓	L	L
H	L	↓	CLK ⁽¹⁾	L
L	H	↓	L	CLK ⁽¹⁾
H	H	↓	CLK ⁽¹⁾	CLK ⁽¹⁾

- (1) After detecting one negative edge on the CLK input, the output follows the input CLK if the control pin is held high.

9 Application and Implementation

NOTE

Information in the following applications sections is not part of the TI component specification, and TI does not warrant its accuracy or completeness. TI's customers are responsible for determining suitability of components for their purposes. Customers should validate and test their design implementation to confirm system functionality.

9.1 Application Information

The CDCVF2310 is a LVCMOS buffer solution that can operate up to 200 MHz. Low output skew as well as the ability for glitchless output enable and disable is featured to simultaneously enable or disable buffered clock outputs as necessary in the application.

9.2 Typical Application

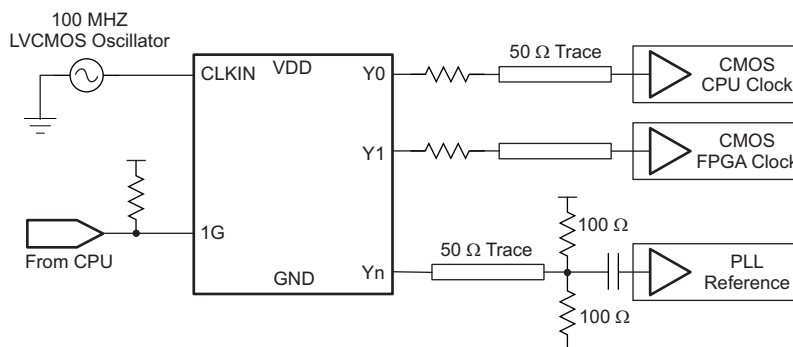

Figure 7. Example System Configuration

9.2.1 Design Requirements

The CDCVF2310 shown in [Figure 7](#) is configured to fan out a 100-MHz signal from a local LVCMOS oscillator. The CPU is configured to control the output state through 1G.

The configuration example is driving three LVCMOS receivers in a backplane application with the following properties:

- The CPU clock can accept a full swing DC-coupled LVCMOS signal. A series resistor is placed near the CDCVF2310 to closely match the characteristic impedance of the trace to minimize reflections.
- The FPGA clock is similarly DC-coupled with an appropriate series resistor placed near the CDCVF2310.
- The PLL in this example can accept a lower amplitude signal, so a Thevenin's equivalent termination is used. The PLL receiver features internal biasing, so AC-coupling can be used when common-mode voltage is mismatched.

9.2.2 Detailed Design Procedure

Refer to [Electrical Characteristics](#) table to determine the appropriate series resistance needed for matching the output impedance of the CDCVF2310 to that of the characteristic impedance of the transmission line.

Typical Application (continued)

9.2.3 Application Curves

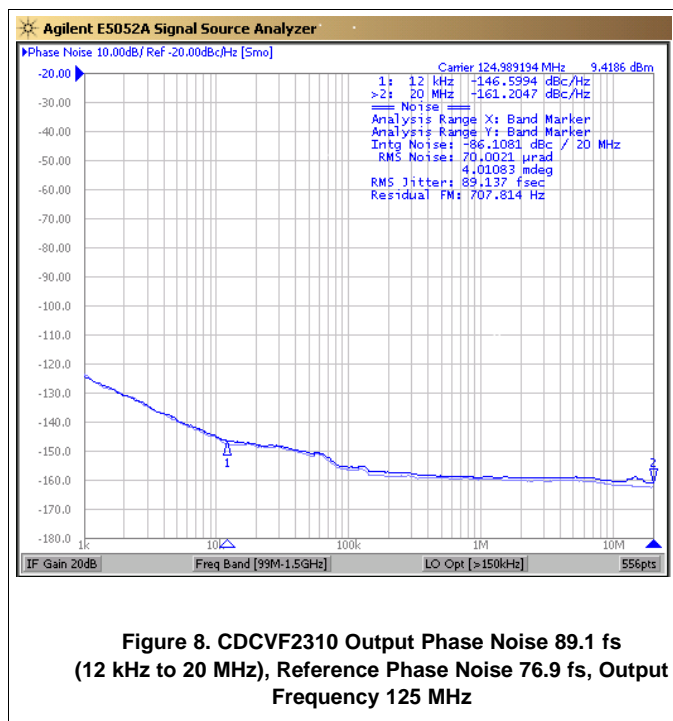

Figure 8. CDCVF2310 Output Phase Noise 89.1 fs (12 kHz to 20 MHz), Reference Phase Noise 76.9 fs, Output Frequency 125 MHz

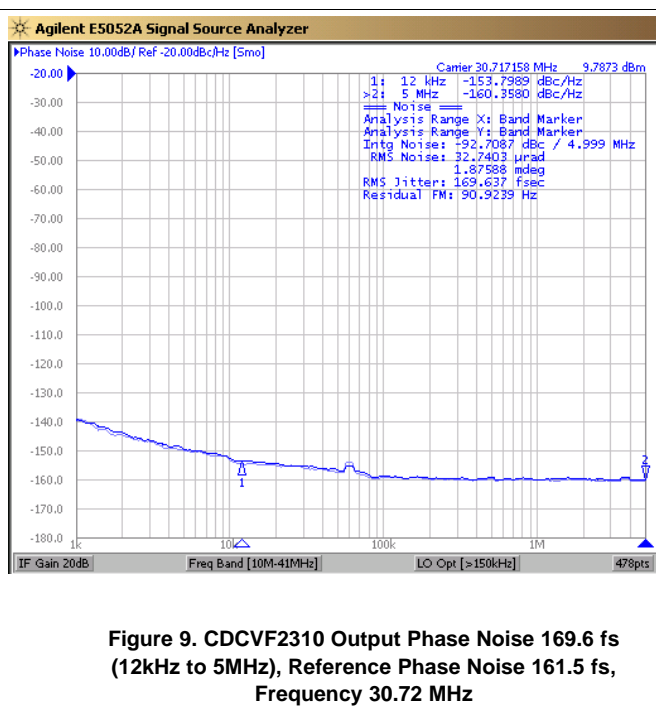

Figure 9. CDCVF2310 Output Phase Noise 169.6 fs (12kHz to 5MHz), Reference Phase Noise 161.5 fs, Frequency 30.72 MHz

The low-additive jitter of the CDCVF2310 can be seen in the previous application plots. The low-noise, 125-MHz input source drives the CDCVF2310, resulting in 45-fs RMS additive jitter when integrated from 12 kHz to 20 MHz for this configuration. The low-noise 30.72-MHz input source drives the CDCVF2310, resulting in 52-fs RMS additive jitter when integrated from 12 kHz to 5 MHz for this configuration.

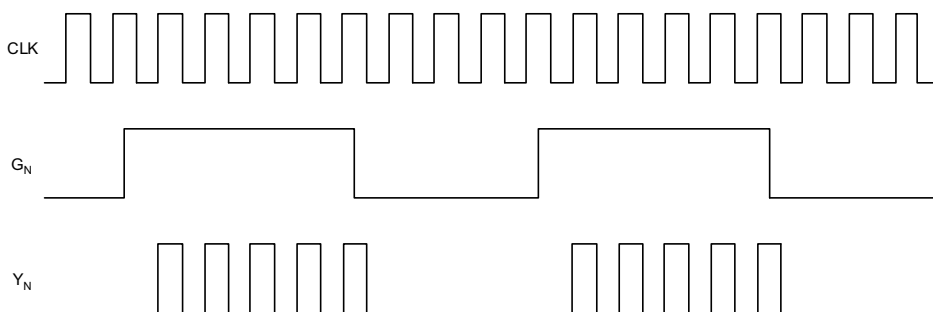

Figure 10. CDCVF2310 Configured as Gate Function for Output Clock

The CDCVF2310 can be configured to generate a gated clock using the G_N . Please refer to [Output Enable Glitch Suppression Circuit](#) for required timings.

10 Power Supply Recommendations

High-performance clock buffers are sensitive to noise on the power supply, which can dramatically increase the additive jitter of the buffer. Thus, it is essential to reduce noise from the system power supply, especially when jitter or phase noise is critical to applications.

Filter capacitors are used to eliminate the low-frequency noise from the power supply, where the bypass capacitors provide the very low impedance path for high-frequency noise and guards the power supply system against induced fluctuations. These bypass capacitors also provide instantaneous current surges as required by the device and should have low equivalent series resistance (ESR). To properly use the bypass capacitors, they must be placed very close to the power-supply terminals and laid out with short loops to minimize inductance. TI recommends adding as many high-frequency (for example, 0.1 μF) bypass capacitors, as there are supply terminals in the package. TI recommends, but does not require, inserting a ferrite bead between the board power supply and the chip power supply that isolates the high-frequency switching noises generated by the clock buffer; these beads prevent the switching noise from leaking into the board supply. It is imperative to choose an appropriate ferrite bead with very low DC resistance to provide adequate isolation between the board supply and the chip supply, as well as to maintain a voltage at the supply terminals that is greater than the minimum voltage required for proper operation.

Figure 12 shows this recommended power supply decoupling method.

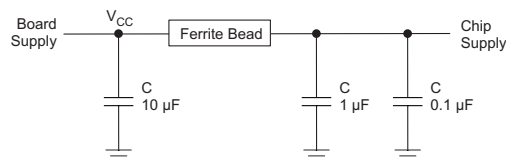

Figure 11. Power Supply Decoupling

11 Layout

11.1 Layout Guidelines

Figure 12 shows a conceptual layout detailing recommended placement of power supply bypass capacitors. For component side mounting, use 0402 body size capacitors to facilitate signal routing. Keep the connections between the bypass capacitors and the power supply on the device as short as possible. Ground the other side of the capacitor using a low-impedance connection to the ground plane.

11.2 Layout Example

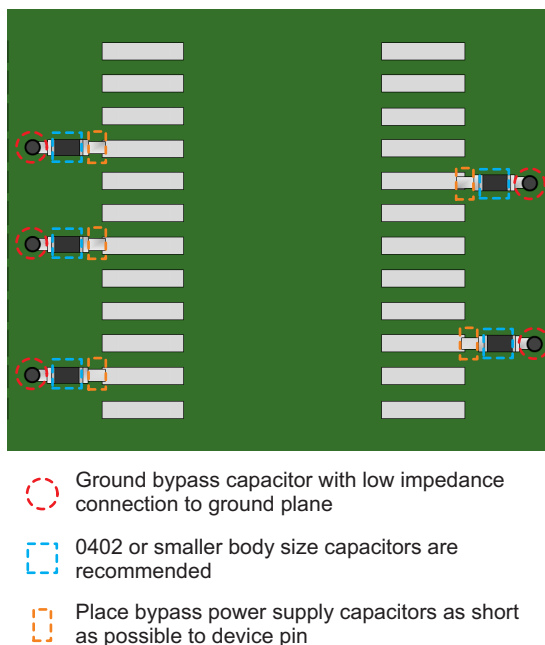

Figure 12. PCB Conceptual Layout

11.3 Thermal Considerations

CDCVF2310 supports high ambient temperature up to 105°C. The system designer needs to ensure that the maximum junction temperature is not exceeded. Following Equation 1 can be used to calculate the junction temperature based on the measured case temperature. The case temperature is defined as the hottest temperature on the top of the device. The case temperature measurement can be performed with (in order of accuracy) an IR camera, a fluor-optic probe, a thermocouple, or IR gun with a maximum field view of 4-mm diameter just to name a few techniques. Further information can be found at [SPRA953](#) and [SLUA566](#)

$$T_{\text{junction}} = T_{\text{case}} + (\Psi_{\text{tj}} \times \text{Power}) \quad (1)$$

12 Device and Documentation Support

12.1 Documentation Support

12.1.1 Related Documentation

For related documentation, see the following:

Using Thermal Calculation Tools for Analog Components, [SLUA566](#)

12.2 Community Resources

The following links connect to TI community resources. Linked contents are provided "AS IS" by the respective contributors. They do not constitute TI specifications and do not necessarily reflect TI's views; see TI's [Terms of Use](#).

TI E2E™ Online Community *TI's Engineer-to-Engineer (E2E) Community*. Created to foster collaboration among engineers. At [e2e.ti.com](#), you can ask questions, share knowledge, explore ideas and help solve problems with fellow engineers.

Design Support *TI's Design Support* Quickly find helpful E2E forums along with design support tools and contact information for technical support.

12.3 Trademarks

E2E is a trademark of Texas Instruments.
All other trademarks are the property of their respective owners.

12.4 Electrostatic Discharge Caution



These devices have limited built-in ESD protection. The leads should be shorted together or the device placed in conductive foam during storage or handling to prevent electrostatic damage to the MOS gates.

12.5 Glossary

[SLYZ022](#) — *TI Glossary*.

This glossary lists and explains terms, acronyms, and definitions.

13 Mechanical, Packaging, and Orderable Information

The following pages include mechanical, packaging, and orderable information. This information is the most current data available for the designated devices. This data is subject to change without notice and revision of this document. For browser-based versions of this data sheet, refer to the left-hand navigation.

PACKAGING INFORMATION

Orderable Device	Status (1)	Package Type	Package Drawing	Pins	Package Qty	Eco Plan (2)	Lead/Ball Finish (6)	MSL Peak Temp (3)	Op Temp (°C)	Device Marking (4/5)	Samples
CDCVF2310PW	ACTIVE	TSSOP	PW	24	60	Green (RoHS & no Sb/Br)	CU NIPDAU	Level-1-260C-UNLIM	-40 to 85	CKV2310	Samples
CDCVF2310PWG4	ACTIVE	TSSOP	PW	24	60	Green (RoHS & no Sb/Br)	CU NIPDAU	Level-1-260C-UNLIM	-40 to 85	CKV2310	Samples
CDCVF2310PWR	ACTIVE	TSSOP	PW	24	2000	Green (RoHS & no Sb/Br)	CU NIPDAU	Level-1-260C-UNLIM	-40 to 85	CKV2310	Samples
CDCVF2310PWRG4	ACTIVE	TSSOP	PW	24	2000	Green (RoHS & no Sb/Br)	CU NIPDAU	Level-1-260C-UNLIM	-40 to 85	CKV2310	Samples

(1) The marketing status values are defined as follows:

ACTIVE: Product device recommended for new designs.

LIFEBUY: TI has announced that the device will be discontinued, and a lifetime-buy period is in effect.

NRND: Not recommended for new designs. Device is in production to support existing customers, but TI does not recommend using this part in a new design.

PREVIEW: Device has been announced but is not in production. Samples may or may not be available.

OBSELETE: TI has discontinued the production of the device.

(2) Eco Plan - The planned eco-friendly classification: Pb-Free (RoHS), Pb-Free (RoHS Exempt), or Green (RoHS & no Sb/Br) - please check <http://www.ti.com/productcontent> for the latest availability information and additional product content details.

TBD: The Pb-Free/Green conversion plan has not been defined.

Pb-Free (RoHS): TI's terms "Lead-Free" or "Pb-Free" mean semiconductor products that are compatible with the current RoHS requirements for all 6 substances, including the requirement that lead not exceed 0.1% by weight in homogeneous materials. Where designed to be soldered at high temperatures, TI Pb-Free products are suitable for use in specified lead-free processes.

Pb-Free (RoHS Exempt): This component has a RoHS exemption for either 1) lead-based flip-chip solder bumps used between the die and package, or 2) lead-based die adhesive used between the die and leadframe. The component is otherwise considered Pb-Free (RoHS compatible) as defined above.

Green (RoHS & no Sb/Br): TI defines "Green" to mean Pb-Free (RoHS compatible), and free of Bromine (Br) and Antimony (Sb) based flame retardants (Br or Sb do not exceed 0.1% by weight in homogeneous material)

(3) MSL, Peak Temp. - The Moisture Sensitivity Level rating according to the JEDEC industry standard classifications, and peak solder temperature.

(4) There may be additional marking, which relates to the logo, the lot trace code information, or the environmental category on the device.

(5) Multiple Device Markings will be inside parentheses. Only one Device Marking contained in parentheses and separated by a "~" will appear on a device. If a line is indented then it is a continuation of the previous line and the two combined represent the entire Device Marking for that device.

(6) Lead/Ball Finish - Orderable Devices may have multiple material finish options. Finish options are separated by a vertical ruled line. Lead/Ball Finish values may wrap to two lines if the finish value exceeds the maximum column width.

Important Information and Disclaimer: The information provided on this page represents TI's knowledge and belief as of the date that it is provided. TI bases its knowledge and belief on information provided by third parties, and makes no representation or warranty as to the accuracy of such information. Efforts are underway to better integrate information from third parties. TI has taken and continues to take reasonable steps to provide representative and accurate information but may not have conducted destructive testing or chemical analysis on incoming materials and chemicals. TI and TI suppliers consider certain information to be proprietary, and thus CAS numbers and other limited information may not be available for release.

In no event shall TI's liability arising out of such information exceed the total purchase price of the TI part(s) at issue in this document sold by TI to Customer on an annual basis.

OTHER QUALIFIED VERSIONS OF CDCVF2310 :

- Enhanced Product: [CDCVF2310-EP](#)

NOTE: Qualified Version Definitions:

- Enhanced Product - Supports Defense, Aerospace and Medical Applications

TAPE AND REEL INFORMATION



QUADRANT ASSIGNMENTS FOR PIN 1 ORIENTATION IN TAPE



*All dimensions are nominal

Device	Package Type	Package Drawing	Pins	SPQ	Reel Diameter (mm)	Reel Width W1 (mm)	A0 (mm)	B0 (mm)	K0 (mm)	P1 (mm)	W (mm)	Pin1 Quadrant
CDCVF2310PWR	TSSOP	PW	24	2000	330.0	16.4	6.95	8.3	1.6	8.0	16.0	Q1

TAPE AND REEL BOX DIMENSIONS



*All dimensions are nominal

Device	Package Type	Package Drawing	Pins	SPQ	Length (mm)	Width (mm)	Height (mm)
CDCVF2310PWR	TSSOP	PW	24	2000	367.0	367.0	38.0

PW (R-PDSO-G24)

PLASTIC SMALL OUTLINE

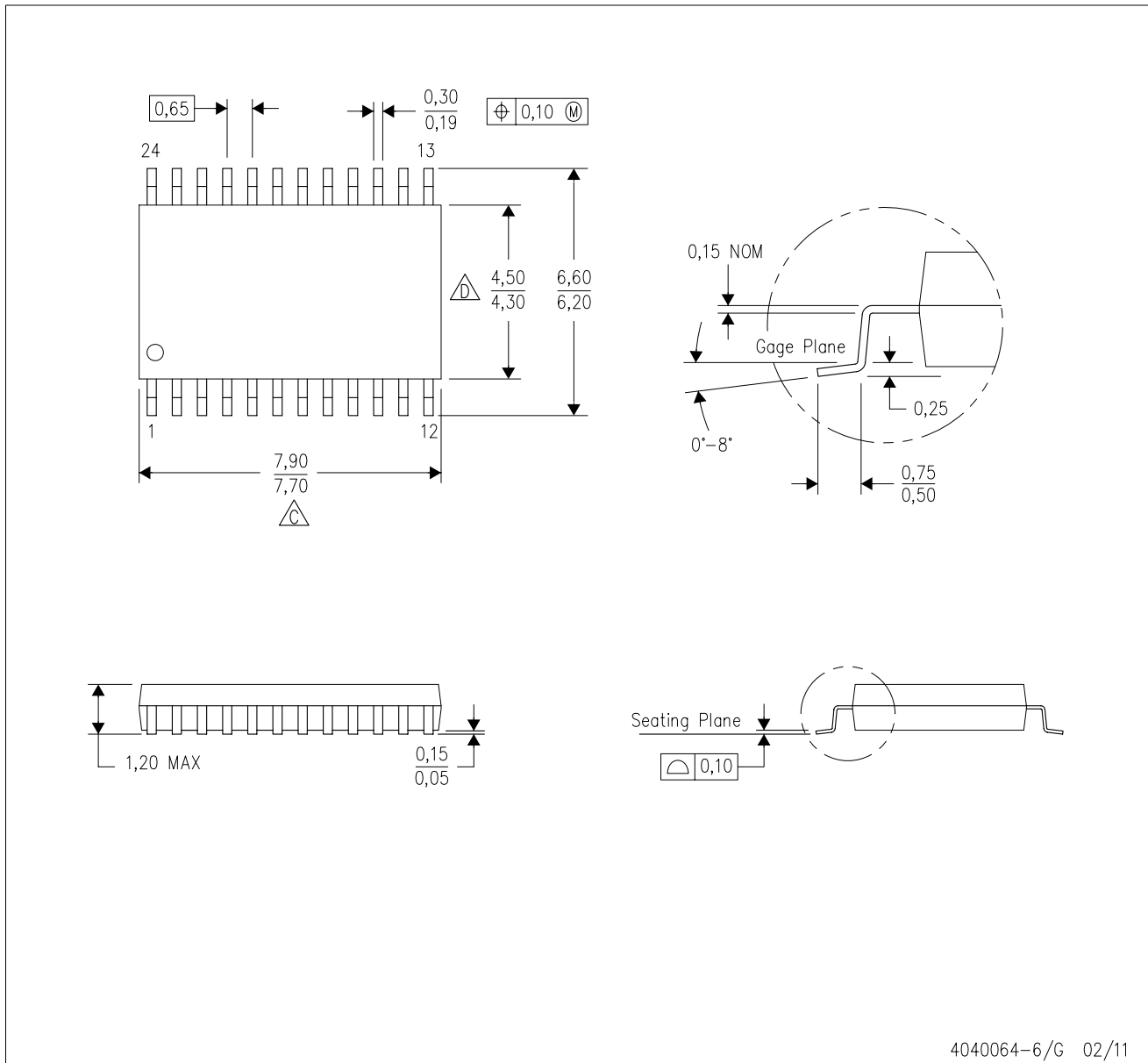

4040064-6/G 02/11

- NOTES:
- A. All linear dimensions are in millimeters. Dimensioning and tolerancing per ASME Y14.5M-1994.
 - B. This drawing is subject to change without notice.
 -  C. Body length does not include mold flash, protrusions, or gate burrs. Mold flash, protrusions, or gate burrs shall not exceed 0,15 each side.
 -  D. Body width does not include interlead flash. Interlead flash shall not exceed 0,25 each side.
 - E. Falls within JEDEC MO-153

PW (R-PDSO-G24)

PLASTIC SMALL OUTLINE

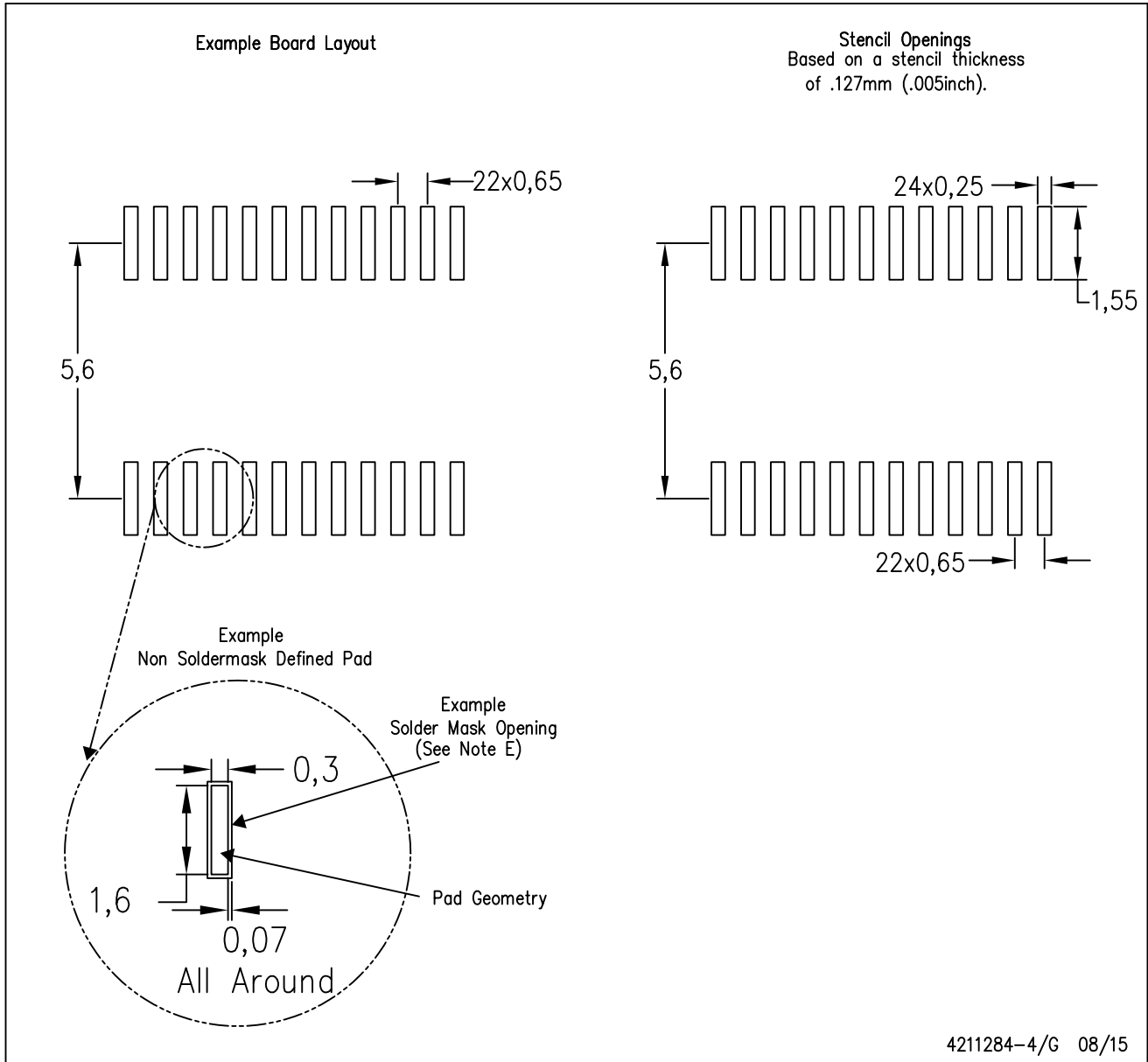

- NOTES:
- All linear dimensions are in millimeters.
 - This drawing is subject to change without notice.
 - Publication IPC-7351 is recommended for alternate design.
 - Laser cutting apertures with trapezoidal walls and also rounding corners will offer better paste release. Customers should contact their board assembly site for stencil design recommendations. Refer to IPC-7525 for other stencil recommendations.
 - Customers should contact their board fabrication site for solder mask tolerances between and around signal pads.

IMPORTANT NOTICE

Texas Instruments Incorporated and its subsidiaries (TI) reserve the right to make corrections, enhancements, improvements and other changes to its semiconductor products and services per JESD46, latest issue, and to discontinue any product or service per JESD48, latest issue. Buyers should obtain the latest relevant information before placing orders and should verify that such information is current and complete. All semiconductor products (also referred to herein as "components") are sold subject to TI's terms and conditions of sale supplied at the time of order acknowledgment.

TI warrants performance of its components to the specifications applicable at the time of sale, in accordance with the warranty in TI's terms and conditions of sale of semiconductor products. Testing and other quality control techniques are used to the extent TI deems necessary to support this warranty. Except where mandated by applicable law, testing of all parameters of each component is not necessarily performed.

TI assumes no liability for applications assistance or the design of Buyers' products. Buyers are responsible for their products and applications using TI components. To minimize the risks associated with Buyers' products and applications, Buyers should provide adequate design and operating safeguards.

TI does not warrant or represent that any license, either express or implied, is granted under any patent right, copyright, mask work right, or other intellectual property right relating to any combination, machine, or process in which TI components or services are used. Information published by TI regarding third-party products or services does not constitute a license to use such products or services or a warranty or endorsement thereof. Use of such information may require a license from a third party under the patents or other intellectual property of the third party, or a license from TI under the patents or other intellectual property of TI.

Reproduction of significant portions of TI information in TI data books or data sheets is permissible only if reproduction is without alteration and is accompanied by all associated warranties, conditions, limitations, and notices. TI is not responsible or liable for such altered documentation. Information of third parties may be subject to additional restrictions.

Resale of TI components or services with statements different from or beyond the parameters stated by TI for that component or service voids all express and any implied warranties for the associated TI component or service and is an unfair and deceptive business practice. TI is not responsible or liable for any such statements.

Buyer acknowledges and agrees that it is solely responsible for compliance with all legal, regulatory and safety-related requirements concerning its products, and any use of TI components in its applications, notwithstanding any applications-related information or support that may be provided by TI. Buyer represents and agrees that it has all the necessary expertise to create and implement safeguards which anticipate dangerous consequences of failures, monitor failures and their consequences, lessen the likelihood of failures that might cause harm and take appropriate remedial actions. Buyer will fully indemnify TI and its representatives against any damages arising out of the use of any TI components in safety-critical applications.

In some cases, TI components may be promoted specifically to facilitate safety-related applications. With such components, TI's goal is to help enable customers to design and create their own end-product solutions that meet applicable functional safety standards and requirements. Nonetheless, such components are subject to these terms.

No TI components are authorized for use in FDA Class III (or similar life-critical medical equipment) unless authorized officers of the parties have executed a special agreement specifically governing such use.

Only those TI components which TI has specifically designated as military grade or "enhanced plastic" are designed and intended for use in military/aerospace applications or environments. Buyer acknowledges and agrees that any military or aerospace use of TI components which have **not** been so designated is solely at the Buyer's risk, and that Buyer is solely responsible for compliance with all legal and regulatory requirements in connection with such use.

TI has specifically designated certain components as meeting ISO/TS16949 requirements, mainly for automotive use. In any case of use of non-designated products, TI will not be responsible for any failure to meet ISO/TS16949.

Products

Audio	www.ti.com/audio
Amplifiers	amplifier.ti.com
Data Converters	dataconverter.ti.com
DLP® Products	www.dlp.com
DSP	dsp.ti.com
Clocks and Timers	www.ti.com/clocks
Interface	interface.ti.com
Logic	logic.ti.com
Power Mgmt	power.ti.com
Microcontrollers	microcontroller.ti.com
RFID	www.ti-rfid.com
OMAP Applications Processors	www.ti.com/omap
Wireless Connectivity	www.ti.com/wirelessconnectivity

Applications

Automotive and Transportation	www.ti.com/automotive
Communications and Telecom	www.ti.com/communications
Computers and Peripherals	www.ti.com/computers
Consumer Electronics	www.ti.com/consumer-apps
Energy and Lighting	www.ti.com/energy
Industrial	www.ti.com/industrial
Medical	www.ti.com/medical
Security	www.ti.com/security
Space, Avionics and Defense	www.ti.com/space-avionics-defense
Video and Imaging	www.ti.com/video

TI E2E Community

e2e.ti.com