

Features

- 50 to 166 MHz operating frequency range
- Wide range of spread selections: 9
- Accepts clock and crystal inputs
- Low power dissipation
 - 70 mW- Typ at 66 MHz
- Frequency spread disable function
- Center spread modulation
- Low cycle-to-cycle jitter
- 8-pin SOIC Package

Functional Description

CY25561 is a spread spectrum clock generator (SSCG) IC used to reduce electromagnetic Interference (EMI) found in today's high speed digital electronic systems.

CY25561 uses a Cypress proprietary phase-locked loop (PLL) and spread spectrum clock (SSC) technology to synthesize and frequency modulate the input frequency of the reference clock. By doing this, the measured EMI at the fundamental and harmonic frequencies of clock (SSCLK) is reduced.

This reduction in radiated energy can significantly reduce the cost of complying with regulatory requirements and time to market without degrading the system performance.

CY25561 is a very simple and versatile device to use. The frequency and spread percentage range is selected by programming S0 and S1 digital inputs. These inputs use three logic states including high (H), low (L), and middle (M) logic levels to select one of the nine available spread percentage ranges. Refer to [Table 1](#) for programming details.

CY25561 is intended for use with applications with a reference frequency in the range of 50 to 166 MHz.

A wide range of digitally selectable spread percentages is made possible by using tri-level (high, low, and middle) logic at the S0 and S1 digital control inputs.

The output spread (frequency modulation) is symmetrically centered on the input frequency.

Spread spectrum clock control (SSCC) function enables or disables the frequency spread and is provided for easy comparison of system performance during EMI testing.

CY25561 is available in an eight-pin SOIC package with a 0 °C to 70 °C operating temperature range.

For a complete list of related documentation, click [here](#).

Logic Block Diagram

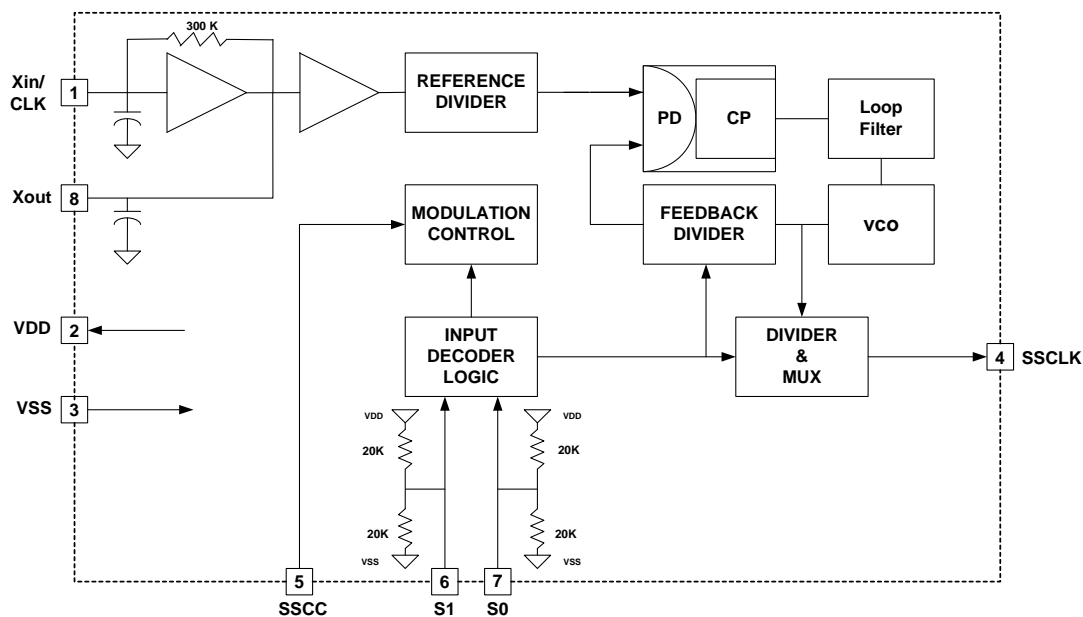

Note: Refer to the CY25560 data sheet for operation at frequencies from 25 to 100 MHz.

Contents

Pin Configuration	3	Package Drawing and Dimensions	9
Pin Definitions	3	Acronyms	10
Tri-level Logic	4	Document Conventions	10
SSCG Theory of Operation	4	Units of Measure	10
EMI	4	Document History Page	11
SSCG	4	Sales, Solutions, and Legal Information	12
Modulation Rate	5	Worldwide Sales and Design Support	12
CY25561 Application Schematic	6	Products	12
Absolute Maximum Ratings	7	PSoC® Solutions	12
DC Electrical Characteristics	7	Cypress Developer Community	12
XIN/CLK DC Specifications	7	Technical Support	12
Electrical Timing Characteristics	7		
Ordering Information	8		
Ordering Code Definitions	8		

Pin Configuration

Figure 1. 8-pin SOIC pinout

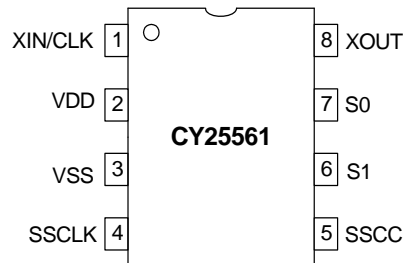

Pin Definitions

Pin	Name	Type	Description
1	X _{IN} / CLK	I	Clock or crystal connection input. Refer to Table 1 for input frequency range selection.
2	V _{DD}	P	Positive power supply
3	V _{SS}	P	Power supply ground
4	SSCLK	O	Modulated clock output
5	SSCC	I	Spread spectrum clock control (enable/disable) function. SSCG function is enabled when input is high and disabled when input is low. This pin is pulled high internally.
6	S1	I	Tri-level logic input control pin used to select frequency and bandwidth. Frequency/Bandwidth selection and tri-level logic programming. See Figure 2. Pin 6 has internal resistor divider network to V _{DD} and V _{SS} . Refer to Logic Block Diagram on page 1.
7	S0	I	Tri-level logic input control pin used to select frequency and bandwidth. Frequency/Bandwidth selection and tri-level logic programming. See Figure 2. Pin 7 has internal resistor divider network to V _{DD} and V _{SS} . Refer to Logic Block Diagram on page 1.
8	X _{OUT}	O	Oscillator output pin connected to crystal. Leave this pin unconnected if an external clock drives X _{IN} / CLK.

Table 1. Frequency and Spread Percentage Selection (Center Spread)

50–100 MHz (Low Range)						
Input Frequency (MHz)	S1=M S0=M (%)	S1=M S0=0 (%)	S1=1 S0=0 (%)	S1=0 S0=0 (%)	S1=0 S0=M (%)	Select the Frequency and Center Spread % desired and then set S1, S0 as indicated.
50–60	4.3	3.9	3.3	2.9	2.7	
60–70	4.0	3.6	3.1	2.6	2.5	
70–80	3.8	3.4	2.9	2.5	2.4	
80–100	3.5	3.1	2.7	2.2	2.1	

100–166 MHz (High Range)					
Input Frequency (MHz)	S1=1 S0=M (%)	S1=0 S0=1 (%)	S1=1 S0=1 (%)	S1=M S0=1 (%)	Select the Frequency and Center Spread % desired and then set S1, S0 as indicated.
100–120	3.0	2.4	1.5	1.3	
120–130	2.7	2.1	1.4	1.1	
130–140	2.6	2.0	1.3	1.1	
140–150	2.6	2.0	1.3	1.1	
150–166	2.5	1.8	1.2	1.0	

Tri-level Logic

With binary logic, four states can be programmed with two control lines, whereas tri-level logic can program nine logic states using two control lines. Tri-level logic in CY25561 is implemented by defining a third logic state in addition to the standard logic “1” and “0”. Pins 6 and 7 of CY25561 recognize a logic state by the voltage applied to the respective pin. These states are defined as “0” (low), “M” (middle), and “1” (one). Each of these states has a defined voltage range that is interpreted by CY25561 as a “0,” “M,” or “1” logic state. Refer to [DC Electrical Characteristics on page 7](#) for voltage ranges for each logic state. CY25561 has two equal value resistors connected internally to pin 6 and pin 7 that produce the default “M” state. Pins 6 and/or 7 can be tied directly to ground or V_{DD} to program a logic “0” or “1” state, respectively. Refer to [Figure 2](#) for examples.

Figure 2. Tri-level Logic Examples

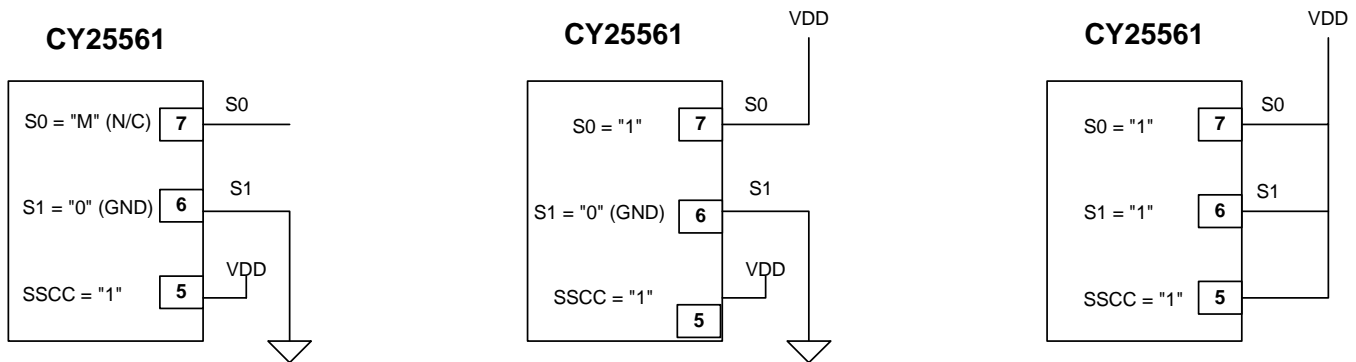

SSCG Theory of Operation

CY25561 is a PLL-type clock generator using a proprietary Cypress design. By precisely controlling the bandwidth of the output clock, CY25561 becomes a low-EMI clock generator. The theory and detailed operation of CY25561 is discussed in the following sections.

EMI

All digital clocks generate unwanted energy in their harmonics. Conventional digital clocks are square waves with a duty cycle that is very close to 50 percent. Because of this 50/50 duty cycle, digital clocks generate most of their harmonic energy in odd harmonics, that is; third, fifth, seventh, etc. The amount of energy contained in the fundamental and odd harmonics can be reduced by increasing the bandwidth of the fundamental clock frequency. Conventional digital clocks have a very high Q factor; all the energy at that frequency is concentrated in a very narrow bandwidth, and consequently, higher energy peaks. Regulatory agencies test electronic equipment by the amount of peak energy radiated from the equipment. By reducing the peak energy at the fundamental and harmonic frequencies, the equipment under test is able to satisfy agency requirements for EMI. Conventional methods of reducing EMI use shielding, filtering, multilayer PCBs, etc. CY25561 uses the approach of reducing the peak energy in the clock by increasing the clock bandwidth, and lowering the Q.

SSCG

SSCG uses a patented technology of modulating the clock over a very narrow bandwidth and controlled rate of change, both

peak and cycle-to-cycle. CY25561 takes a narrow band digital reference clock in the range of 50 to 166 MHz and produces a clock that sweeps between a controlled start and stop frequency and precise rate of change. To understand what happens to a clock when SSCG is applied, consider a 65 MHz clock with a 50 percent duty cycle, as shown in the following figure:

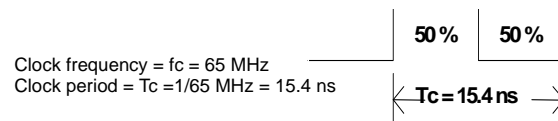

If this clock is applied to the Xin/CLK pin of CY25561, the output clock at pin 4 (SSCLK) sweeps back and forth between two frequencies. These two frequencies, F1 and F2, are used to calculate total amount of spread or bandwidth applied to the reference clock at pin 1. As the clock is making the transition from F1 to F2, the amount of time and sweep waveform play a very important role in the amount of EMI reduction realized from an SSCG clock.

The modulation domain analyzer is used to visualize the sweep waveform and sweep period. [Figure 4 on page 6](#) shows the modulation profile of a 65 MHz SSCG clock. Notice that the actual sweep waveform is not a simple sine or sawtooth waveform. [Figure 4 on page 6](#) also shows a scan of the same SSCG clock using a spectrum analyzer. In this scan, you can see a 6.48 dB reduction in the peak RF energy when using the SSCG clock.

Modulation Rate

Spectrum spread clock generators use frequency modulation (FM) to distribute energy over a specific band of frequencies. The maximum frequency of the clock (Fmax) and minimum frequency of the clock (Fmin) determine this band of frequencies. The time required to transition from Fmin to Fmax and back to Fmin is the period of the modulation rate, Tmod. Modulation rates of SSCG clocks are most commonly referred to in terms of frequency or Fmod = 1/Tmod.

The input clock frequency, Fin, and the internal divider count, Cdiv, determine the modulation rate. In some SSCG clock generators, the selected range determines the internal divider count. In other SSCG clocks, the internal divider count is fixed over the operating range of the part. CY25561 has a fixed divider count, as shown in Figure 3.

Figure 3. SSCG Clock, Part Number, Fin = 65 MHz

Device	Cdiv
CY25561	2332 (All Ranges)

Example:

Device =	CY25561
Fin =	65 MHz
Range =	S1 = 1, S0 = 0

Then;

Modulation Rate = Fmod = 65 MHz/2332 = 27.9 kHz.

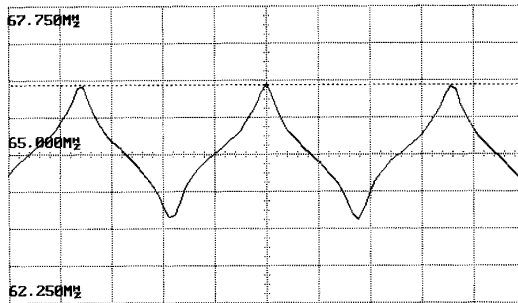

Modulation Profile

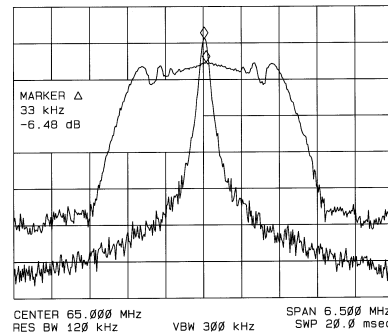

Spectrum

Analyzer

CY25561 Application Schematic

Figure 4. Application Schematic

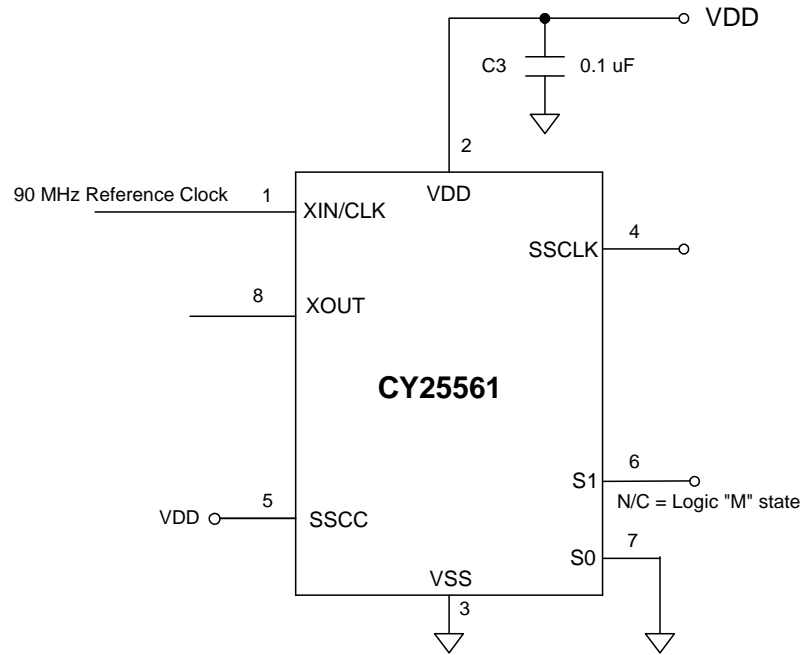

The schematic in [Figure 4](#) above demonstrates how CY25561 is configured in a typical application. This application is using a 90 MHz reference clock connected to pin 1. Because an external reference clock is used, pin 8 (XOUT) is left unconnected.

[Figure 4](#) shows that pin 6 has no connection, which programs the logic "M" state, due to the internal resistor divider network of CY25561. Programming a logic "0" state is as simple as connecting to logic ground, as shown on pin 7.

With this configuration, CY25561 produces an SSCG clock that is at a center frequency of 90 MHz. Referring to [DC Electrical Characteristics on page 7](#), range "M, 0" at 90 MHz generates a modulation profile that has a 3.1 percent peak-to-peak spread.

Absolute Maximum Ratings

Exceeding maximum ratings [1, 2] may shorten the useful life of the device. User guidelines are not tested.

Supply voltage (V_{DD}) -0.5 V to +6.0 V

DC input voltage -0.5 V to $V_{DD} + 0.5$ V
 Junction temperature -40 °C to +140 °C
 Operating temperature 0 °C to 70 °C
 Storage temperature -65 °C to +150 °C
 Static discharge voltage (ESD) 2,000 V min

DC Electrical Characteristics

$V_{DD} = 3.3$ V, $T_A = 25$ °C and C_L (Pin 4) = 15 pF, unless otherwise noted.

Parameter	Description	Conditions	Min	Typ	Max	Unit
V_{DD}	Power supply range	$\pm 10\%$	2.97	3.3	3.63	V
V_{INH}	Input high voltage	S0 and S1 only.	$0.85 \times V_{DD}$	V_{DD}	V_{DD}	V
V_{INM}	Input middle voltage	S0 and S1 only.	$0.40 \times V_{DD}$	$0.50 \times V_{DD}$	$0.60 \times V_{DD}$	V
V_{INL}	Input low voltage	S0 and S1 only.	0.0	0.0	$0.15 \times V_{DD}$	V
V_{OH1}	Output high voltage	$I_{OH} = 6$ mA	2.4	–	–	V
V_{OH2}	Output high voltage	$I_{OH} = 20$ mA	2.0	–	–	V
V_{OL1}	Output low voltage	$I_{OH} = 6$ mA	–	–	0.4	V
V_{OL2}	Output low voltage	$I_{OH} = 20$ mA	–	–	1.2	V
C_{in1}	Input capacitance	X_{IN} / CLK (Pin 1)	3	4	5	pF
C_{in2}	Input capacitance	X_{OUT} (Pin 8)	6	8	10	pF
C_{in2}	Input capacitance	S0, S1, SSCC (Pins 7, 6, 5)	3	4	5	pF
I_{DD1}	Power supply current	Fin = 65 MHz, CL = 0	–	23	30	mA
I_{DD2}	Power supply current	Fin = 166 MHz, CL = 0	–	48	60	mA

X_{IN} /CLK DC Specifications

Parameter	Description	Conditions	Min	Max	Units
$V_{IH(X)}$	Input high voltage, X_{IN} Clock Input	$F \leq 100$ MHz	80	–	% of V_{DD}
		$F \leq 133$ MHz	86	–	% of V_{DD}
		$F \leq 166$ MHz	92	–	% of V_{DD}
$V_{IL(X)}$	Input low voltage, X_{IN} Clock Input		–	15	% of V_{DD}

Electrical Timing Characteristics

$V_{DD} = 3.3$ V, $T_A = 25$ °C and $C_L = 15$ pF, unless otherwise noted.

Parameter	Description	Conditions	Min	Typ	Max	Unit
f_{CLKFR}	Input clock frequency range	$V_{DD} = 3.3$ V	50	–	166	MHz
t_{RISE}	Clock rise time (Pin 4)	SSCLK1 @ 0.4 V–2.4 V	1.1	1.4	1.7	ns
t_{FALL}	Clock fall time (Pin 4)	SSCLK1 @ 0.4 V–2.4 V	1.1	1.4	1.7	ns
D_{TYin}	Input clock duty cycle	X_{IN} / CLK (Pin 1)	30	50	70	%
D_{TYout}	Output clock duty cycle	SSCLK1 (Pin 4)	45	50	55	%
C_{CJ1}	Cycle-to-Cycle jitter	50 MHz–100 MHz, (S1 = M, S0 = M)	–	150	225	ps
C_{CJ2}	Cycle-to-Cycle jitter	100 MHz–166 MHz, (S1 = 1, S0 = M)	–	200	300	ps

Notes

1. Operation at any absolute maximum rating is not implied.
2. Single power supply: The voltage on any input or I/O pin cannot exceed the power pine during power-up.

Package Drawing and Dimensions

Figure 5. 8-pin SOIC (150 Mils) S0815/SZ815/SW815 Package Outline, 51-85066

1. DIMENSIONS IN INCHES[MM] MIN. MAX.
2. PIN 1 ID IS OPTIONAL, ROUND ON SINGLE LEADFRAME RECTANGULAR ON MATRIX LEADFRAME
3. REFERENCE JEDEC MS-012
4. PACKAGE WEIGHT 0.07gms

PART #	
S08.15	STANDARD PKG
SZ08.15	LEAD FREE PKG
SW8.15	LEAD FREE PKG

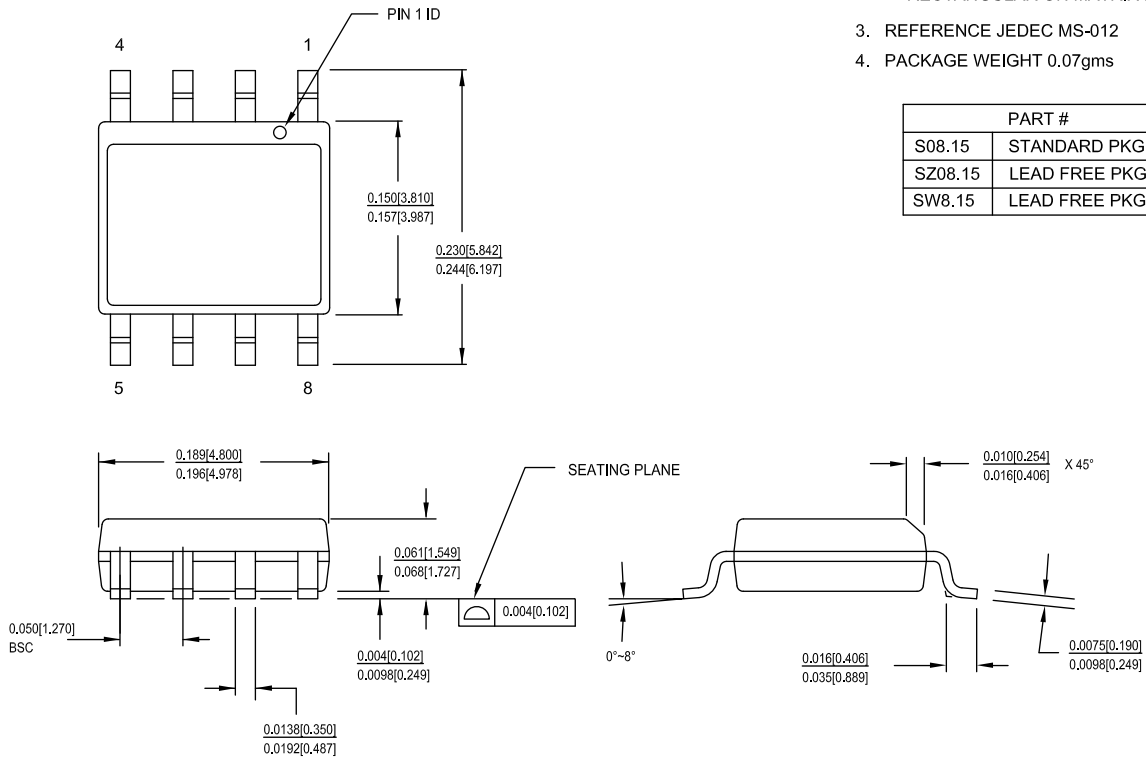

51-85066 *G

Acronyms

Acronym	Description
EMI	Electromagnetic Interference
PCB	Printed Circuit Board
PLL	Phase-Locked Loop
SOIC	Small Outline Integrated Circuit
SSC	Spread Spectrum Clock
SSCC	Spread Spectrum Clock Control
SSCG	Spread Spectrum Clock Generator

Document Conventions

Units of Measure

Symbol	Unit of Measure
°C	degree Celsius
mA	milliampere
ns	nanosecond
%	percent
pF	picofarad
V	volt

Document History Page

Document Title: CY25561, Spread Spectrum Clock Generator Document Number: 38-07242				
Rev.	ECN No.	Submission Date	Orig. of Change	Description of Change
**	115369	07/05/02	OXC	New data sheet.
*A	119443	10/17/02	RGL	Updated Absolute Maximum Ratings (Corrected the values to match the device).
*B	122694	12/27/02	RBI	Updated Absolute Maximum Ratings (Added power up requirements).
*C	2567245	09/16/08	PYG / KVM / AESA	Updated Ordering Information (Replaced CY25561SC with CY25561SXC, CY255651SCT with CY25561SXCT). Updated Package Drawing and Dimensions (Package changed from S8 to SZ8). Updated to new template.
*D	3187957	03/04/2011	CXQ	Updated Package Drawing and Dimensions .
*E	3528781	02/21/2012	PURU	Removed Applications and Benefits section. Added Ordering Code Definitions . Updated Package Drawing and Dimensions . Added Acronyms and Units of Measure . Updated to new template.
*F	3944833	03/26/2013	PURU	Updated Pin Definitions (Replaced "GND" with "V _{SS} " for Name of Pin 3).
*G	4198708	11/21/2013	CINM	Added XIN/CLK DC Specifications . Updated Package Drawing and Dimensions : spec 51-85066 – Changed revision from *E to *F. Updated to new template.
*H	4586478	12/03/2014	AJU	Updated Functional Description : Added "For a complete list of related documentation, click here ." at the end.
*I	4708301	03/31/2015	TAVA	Updated Package Drawing and Dimensions : spec 51-85066 – Changed revision from *F to *G. Completing Sunset Review.

Sales, Solutions, and Legal Information

Worldwide Sales and Design Support

Cypress maintains a worldwide network of offices, solution centers, manufacturer's representatives, and distributors. To find the office closest to you, visit us at [Cypress Locations](#).

Products

Automotive	cypress.com/go/automotive
Clocks & Buffers	cypress.com/go/clocks
Interface	cypress.com/go/interface
Lighting & Power Control	cypress.com/go/powerpsoc cypress.com/go/plc
Memory	cypress.com/go/memory
PSoC	cypress.com/go/psoc
Touch Sensing	cypress.com/go/touch
USB Controllers	cypress.com/go/USB
Wireless/RF	cypress.com/go/wireless

PSoC[®] Solutions

[psoc.cypress.com/solutions](#)
[PSoC 1](#) | [PSoC 3](#) | [PSoC 4](#) | [PSoC 5LP](#)

Cypress Developer Community

[Community](#) | [Forums](#) | [Blogs](#) | [Video](#) | [Training](#)

Technical Support

[cypress.com/go/support](#)

© Cypress Semiconductor Corporation, 2008-2015. The information contained herein is subject to change without notice. Cypress Semiconductor Corporation assumes no responsibility for the use of any circuitry other than circuitry embodied in a Cypress product. Nor does it convey or imply any license under patent or other rights. Cypress products are not warranted nor intended to be used for medical, life support, life saving, critical control or safety applications, unless pursuant to an express written agreement with Cypress. Furthermore, Cypress does not authorize its products for use as critical components in life-support systems where a malfunction or failure may reasonably be expected to result in significant injury to the user. The inclusion of Cypress products in life-support systems application implies that the manufacturer assumes all risk of such use and in doing so indemnifies Cypress against all charges.

Any Source Code (software and/or firmware) is owned by Cypress Semiconductor Corporation (Cypress) and is protected by and subject to worldwide patent protection (United States and foreign), United States copyright laws and international treaty provisions. Cypress hereby grants to licensee a personal, non-exclusive, non-transferable license to copy, use, modify, create derivative works of, and compile the Cypress Source Code and derivative works for the sole purpose of creating custom software and or firmware in support of licensee product to be used only in conjunction with a Cypress integrated circuit as specified in the applicable agreement. Any reproduction, modification, translation, compilation, or representation of this Source Code except as specified above is prohibited without the express written permission of Cypress.

Disclaimer: CYPRESS MAKES NO WARRANTY OF ANY KIND, EXPRESS OR IMPLIED, WITH REGARD TO THIS MATERIAL, INCLUDING, BUT NOT LIMITED TO, THE IMPLIED WARRANTIES OF MERCHANTABILITY AND FITNESS FOR A PARTICULAR PURPOSE. Cypress reserves the right to make changes without further notice to the materials described herein. Cypress does not assume any liability arising out of the application or use of any product or circuit described herein. Cypress does not authorize its products for use as critical components in life-support systems where a malfunction or failure may reasonably be expected to result in significant injury to the user. The inclusion of Cypress' product in a life-support systems application implies that the manufacturer assumes all risk of such use and in doing so indemnifies Cypress against all charges.

Use may be limited by and subject to the applicable Cypress software license agreement.