

18-Bit Registered Transceivers

Features

- FCT-C speed at 4.6 ns
- I_{off} supports partial-power-mode operation
- Edge-rate control circuitry for significantly improved noise characteristics
- Typical output skew < 250 ps
- ESD > 2000V
- TSSOP (19.6-mil pitch) and SSOP (25-mil pitch) packages
- Industrial temperature range of -40°C to $+85^{\circ}\text{C}$
- $V_{CC} = 5\text{V} \pm 10\%$

CY74FCT16500T Features:

- 64 mA sink current, 32 mA source current
- Typical V_{OLP} (ground bounce) < 1.0V at $V_{CC} = 5\text{V}$, $T_A = 25^{\circ}\text{C}$

CY74FCT162500T Features:

- Balanced 24 mA output drivers
- Reduced system switching noise
- Typical V_{OLP} (ground bounce) < 0.6V at $V_{CC} = 5\text{V}$, $T_A = 25^{\circ}\text{C}$

Functional Description

These 18-bit universal bus transceivers can be operated in transparent, latched, or clock modes by combining D-type latches and D-type flip-flops. Data flow in each direction is controlled by output-enable (OEAB and OEBA), latch enable (LEAB and LEBA), and clock inputs (CLKAB and CLKBA) inputs. For A-to-B data flow, the device operates in transparent mode when LEAB is HIGH. When LEAB is LOW, the A data is latched if CLKAB is held at a HIGH or LOW logic level. If LEAB is LOW, the A bus data is stored in the latch/flip-flop on the HIGH-to-LOW transition of CLKAB. OEAB performs the output enable function on the B port. Data flow from B-to-A is similar to that of A-to-B and is controlled by OEBA, LEBA, and CLKBA.

This device is fully specified for partial-power-down applications using I_{off} . The I_{off} circuitry disables the outputs, preventing damaging current backflow through the device when it is powered down.

The CY74FCT16500T is ideally suited for driving high-capacitance loads and low-impedance backplanes.

The CY74FCT162500T has 24-mA balanced output drivers with current limiting resistors in the outputs. This reduces the need for external terminating resistors and provides for minimal undershoot and reduced ground bounce. The CY74FCT162500T is ideal for driving transmission lines.

Logic Block Diagram

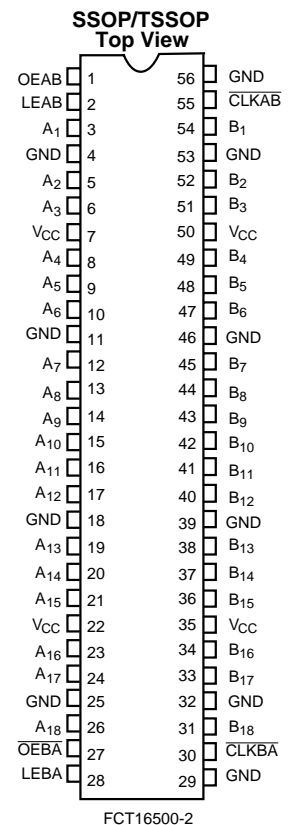
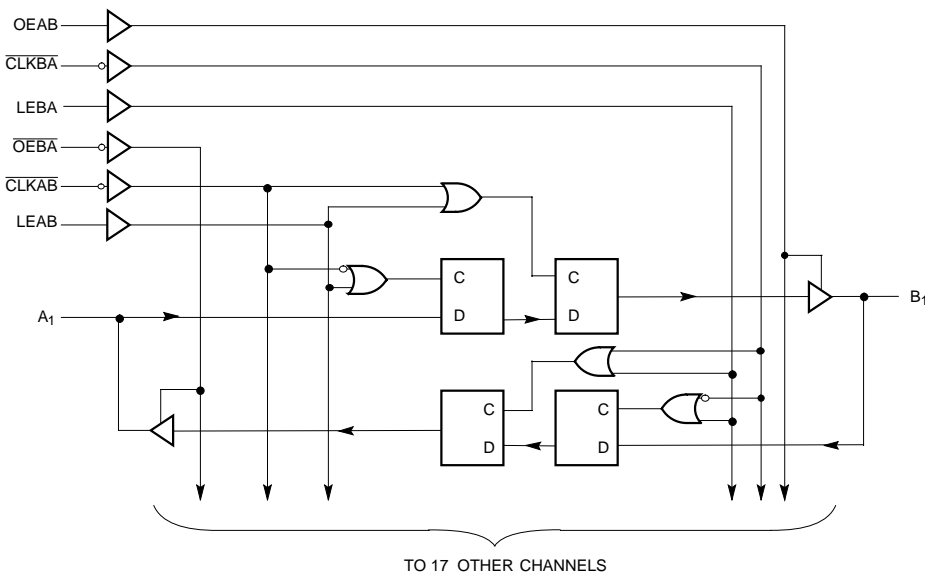

Pin Summary

Name	Description
OEAB	A-to-B Output Enable Input
OEBA	B-to-A Output Enable Input (Active LOW)
LEAB	A-to-B Latch Enable Input
LEBA	B-to-A Latch Enable Input
CLKAB	A-to-B Clock Input (Active LOW)
CLKBA	B-to-A Clock Input (Active LOW)
A	A-to-B Data Inputs or B-to-A Three-State Outputs
B	B-to-A Data Inputs or A-to-B Three-State Outputs

Function Table^[1, 2]

Inputs				Outputs
OEAB	LEAB	CLKAB	A	B
L	X	X	X	Z
H	H	X	L	L
H	H	X	H	H
H	L	↔	L	L
H	L	↔	H	H
H	L	H	X	B ^[3]
H	L	L	X	B ^[4]

Electrical Characteristics Over the Operating Range

Parameter	Description	Test Conditions	Min.	Typ. ^[7]	Max.	Unit
V _{IH}	Input HIGH Voltage		2.0			V
V _{IL}	Input LOW Voltage				0.8	V
V _H	Input Hysteresis ^[8]			100		mV
V _{IK}	Input Clamp Diode Voltage	V _{CC} =Min., I _{IN} =-18 mA		-0.7	-1.2	V
I _{IH}	Input HIGH Current	V _{CC} =Max., V _I =V _{CC}			±1	µA
I _{IL}	Input LOW Current	V _{CC} =Max., V _I =GND.			±1	µA
I _{OZH}	High Impedance Output Current (Three-State Output pins)	V _{CC} =Max., V _{OUT} =2.7V			±1	µA
I _{OZL}	High Impedance Output Current (Three-State Output pins)	V _{CC} =Max., V _{OUT} =0.5V			±1	µA
I _{OS}	Short Circuit Current ^[9]	V _{CC} =Max., V _{OUT} =GND	-80	-140	-200	mA
I _O	Output Drive Current ^[9]	V _{CC} =Max., V _{OUT} =2.5V	-50		-180	mA
I _{OFF}	Power-Off Disable	V _{CC} =0V, V _{OUT} ≤4.5V ^[10]			±1	µA

Notes:

- H = HIGH Voltage Level. L = LOW Voltage Level. X = Don't Care. Z = HIGH Impedance. ↔ = HIGH-to-LOW Transition.
- A-to-B data flow is shown, B-to-A data flow is similar but uses OEBA, LEBA, and CLKBA.
- Output level before the indicated steady-state input conditions were established.
- Output level before the indicated steady-state input conditions were established, provided that CLKAB was LOW before LEAB went LOW.
- Operation beyond the limits set forth may impair the useful life of the device. Unless otherwise noted, these limits are over the operating free-air temperature range.
- Unused inputs must always be connected to an appropriate logic voltage level, preferably either V_{CC} or ground.
- Typical values are at V_{CC}=5.0V, T_A=+25°C ambient.
- This parameter is specified but not tested.
- Not more than one output should be shorted at a time. Duration of short should not exceed one second. The use of high-speed test apparatus and/or sample and hold techniques are preferable in order to minimize internal chip heating and more accurately reflect operational values. Otherwise prolonged shorting of a high output may raise the chip temperature well above normal and thereby cause invalid readings in other parametric tests. In any sequence of parameter tests, I_{OS} tests should be performed last.
- Tested at +25°C.

Maximum Ratings^[5, 6]

(Above which the useful life may be impaired. For user guidelines, not tested.)

Storage Temperature	Com'l	-55°C to +125°C
Ambient Temperature with Power Applied.....	Com'l	-55°C to +125°C
DC Input Voltage		-0.5V to +7.0V
DC Output Voltage		-0.5V to +7.0V
DC Output Current (Maximum Sink Current/Pin)		-60 to +120 mA
Power Dissipation		1.0W
Static Discharge Voltage.....		>2001V (per MIL-STD-883, Method 3015)

Operating Range

Range	Ambient Temperature	V _{CC}
Industrial	-40°C to +85°C	5V ± 10%

Output Drive Characteristics for CY74FCT16500T

Parameter	Description	Test Conditions	Min.	Typ. ^[7]	Max.	Unit
V _{OH}	Output HIGH Voltage	V _{CC} =Min., I _{OH} =-3 mA	2.5	3.5		V
		V _{CC} =Min., I _{OH} =-15 mA	2.4	3.5		
		V _{CC} =Min., I _{OH} =-32 mA	2.0	3.0		
V _{OL}	Output LOW Voltage	V _{CC} =Min., I _{OL} =64 mA		0.2	0.55	V

Output Drive Characteristics for CY74FCT162500T

Parameter	Description	Test Conditions	Min.	Typ. ^[7]	Max.	Unit
I _{ODL}	Output LOW Current ^[9]	V _{CC} =5V, V _{IN} =V _{IH} or V _{IL} , V _{OUT} =1.5V	60	115	150	mA
I _{ODH}	Output HIGH Current ^[9]	V _{CC} =5V, V _{IN} =V _{IH} or V _{IL} , V _{OUT} =1.5V	-60	-115	-150	mA
V _{OH}	Output HIGH Voltage	V _{CC} =Min., I _{OH} =-24 mA	2.4	3.3		V
V _{OL}	Output LOW Voltage	V _{CC} =Min., I _{OL} =24 mA		0.3	0.55	V

Capacitance^[8] (T_A = +25°C, f = 1.0 MHz)

Parameter	Description	Test Conditions	Typ. ^[7]	Max.	Unit
C _{IN}	Input Capacitance	V _{IN} = 0V	4.5	6.0	pF
C _{OUT}	Output Capacitance	V _{OUT} = 0V	5.5	8.0	pF

Power Supply Characteristics

Parameter	Description	Test Conditions		Typ. ^[7]	Max.	Unit
I _{CC}	Quiescent Power Supply Current	V _{CC} =Max.	V _{IN} ≤0.2V, V _{IN} ≥V _{CC} -0.2V	5	500	μA
ΔI _{CC}	Quiescent Power Supply Current (TTL inputs HIGH)	V _{CC} =Max.	V _{IN} =3.4V ^[11]	0.5	1.5	mA
I _{CCD}	Dynamic Power Supply Current ^[12]	V _{CC} =Max., One Input Toggling, 50% Duty Cycle, Outputs Open, OEAB=OEBA=V _{CC} or GND	V _{IN} =V _{CC} or V _{IN} =GND	75	120	μA/MHz
I _C	Total Power Supply Current ^[13]	V _{CC} =Max., f ₀ =10 MHz (CLKAB), f ₁ =5 MHz, 50% Duty Cycle, Outputs Open, One Bit Toggling, OEAB=OEBA=V _{CC} LEAB=GND	V _{IN} =V _{CC} or V _{IN} =GND	0.8	1.7	mA
			V _{IN} =3.4V or V _{IN} =GND	1.3	3.2	mA
		V _{CC} =Max., f ₀ =10 MHz, f ₁ =2.5 MHz, 50% Duty Cycle, Outputs Open, Eighteen Bits Toggling, OEAB=OEBA=V _{CC} LEAB=GND	V _{IN} =V _{CC} or V _{IN} =GND	3.8	6.5 ^[14]	mA
			V _{IN} =3.4V or V _{IN} =GND	8.5	20.8 ^[14]	mA

Notes:

- Per TTL driven input (V_{IN}=3.4V); all other inputs at V_{CC} or GND.
- This parameter is not directly testable, but is derived for use in Total Power Supply calculations.
- $$I_C = I_{QUIESCENT} + I_{INPUTS} + I_{DYNAMIC}$$

$$I_C = I_{CC} + \Delta I_{CC} D_H N_T + I_{CCD} (f_0/2 + f_1 N_1)$$

I_{CC} = Quiescent Current with CMOS input levels
ΔI_{CC} = Power Supply Current for a TTL HIGH input (V_{IN}=3.4V)
D_H = Duty Cycle for TTL inputs HIGH
N_T = Number of TTL inputs at D_H
I_{CCD} = Dynamic Current caused by an input transition pair (HLH or LHL)
f₀ = Clock frequency for registered devices, otherwise zero
f₁ = Input signal frequency
N₁ = Number of inputs changing at f₁
All currents are in milliamps and all frequencies are in megahertz.
- Values for these conditions are examples of the I_{CC} formula. These limits are specified but not tested.

Switching Characteristics Over the Operating Range^[15]

Parameter	Description	CY74FCT162500AT		CY74FCT16500CT/ CY74FCT162500CT		Unit	Fig. No. ^[16]
		Min.	Max.	Min.	Max.		
f _{MAX}	CLKA \bar or CLKB \bar frequency		150		150	MHz	
t _{PLH} t _{PHL}	Propagation Delay A to B or B to A	1.5	5.1	1.5	4.6	ns	1, 3
t _{PLH} t _{PHL}	Propagation Delay LEBA to A, LEAB to B	1.5	5.6	1.5	5.3	ns	1, 5
t _{PLH} t _{PHL}	Propagation Delay CLKBA to A, CLKAB to B	1.5	5.6	1.5	5.3	ns	1, 5
t _{PZH} t _{PZL}	Output Enable Time OEBA to A, OEAB to B	1.5	6.0	1.5	5.4	ns	1, 7, 8
t _{PHZ} t _{PLZ}	Output Disable Time OEBA to A, OEAB to B	1.5	5.6	1.5	5.2	ns	1, 7, 8
t _{SU}	Set-Up Time, HIGH or LOW A to CLKA \bar , B to CLKB \bar	3.0		3.0		ns	9
t _H	Hold Time, HIGH or LOW A to CLKA \bar , B to CLKB \bar	0		0		ns	9
t _{SU}	Set-Up Time, HIGH or LOW A to LEAB, B to LEBA	Clock HIGH	3.0		3.0	ns	4
		Clock LOW	1.5		1.5	ns	4
t _H	Hold Time, HIGH or LOW A to LEAB, B to LEBA	1.5		1.5		ns	4
t _W	LEAB or LEBA Pulse Width HIGH	3.0		2.5		ns	5
t _W	CLKA \bar or CLKB \bar Pulse Width HIGH or LOW	3.0		3.0		ns	5
t _{SK(O)}	Output Skew ^[17]		0.5		0.5	ns	

Ordering Information CY74FCT16500T

Speed (ns)	Ordering Code	Package Name	Package Type	Operating Range
4.6	CY74FCT16500CTPACT	Z56	56-Lead (240-Mil) TSSOP	Industrial
	CY74FCT16500CTPVC/PVCT	O56	56-Lead (300-Mil) SSOP	

Ordering Information CY74FCT162500T

Speed (ns)	Ordering Code	Package Name	Package Type	Operating Range
4.6	CY74FCT162500CTPVC	O56	56-Lead (300-Mil) SSOP	Industrial
	74FCT162500CTPVCT	O56	56-Lead (300-Mil) SSOP	
5.1	CT74FCT162500ATPVC	O56	56-Lead (300-Mil) SSOP	Industrial
	74FCT162500ATPVCT	O56	56-Lead (300-Mil) SSOP	

Notes:

15. Minimum limits are specified but not tested on Propagation Delays.
16. See "Parameter Measurement Information" in the General Information section.
17. Skew between any two outputs of the same package switching in the same direction. This parameter is ensured by design.

Package Diagrams

56-Lead Shrunken Small Outline Package O56

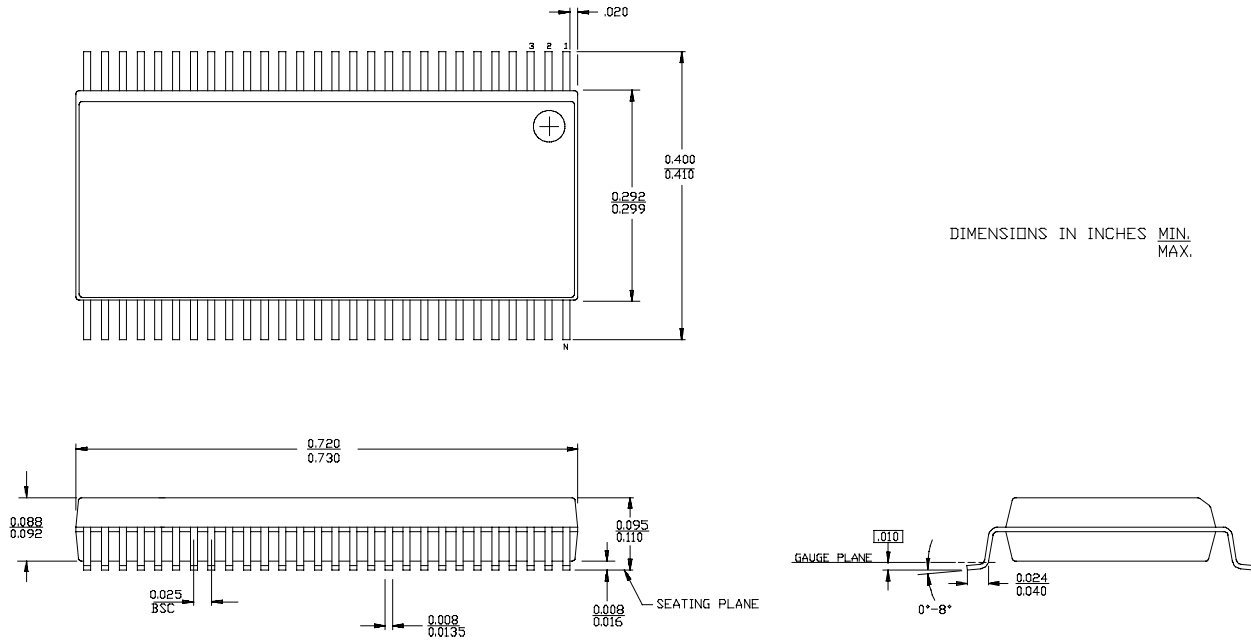

56-Lead Thin Shrunken Small Outline Package Z56

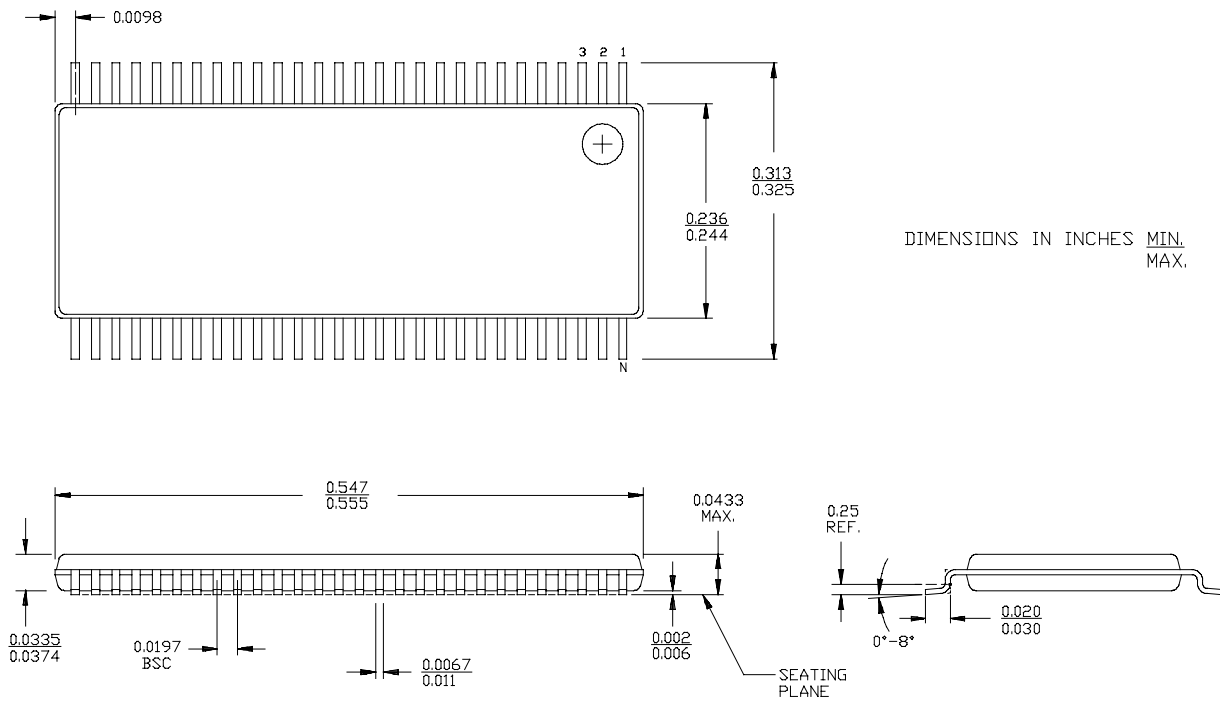

PACKAGING INFORMATION

Orderable Device	Status (1)	Package Type	Package Drawing	Pins	Package Qty	Eco Plan (2)	Lead/Ball Finish (6)	MSL Peak Temp (3)	Op Temp (°C)	Device Marking (4/5)	Samples
74FCT16500CTPVCG4	OBSOLETE	SSOP	DL	56		TBD	Call TI	Call TI	-40 to 85		
CY74FCT16500CTPVC	OBSOLETE	SSOP	DL	56		TBD	Call TI	Call TI	-40 to 85		
CY74FCT16500CTPVCT	ACTIVE	SSOP	DL	56	1000	Green (RoHS & no Sb/Br)	CU NIPDAU	Level-1-260C-UNLIM	-40 to 85	FCT16500C	Samples

(1) The marketing status values are defined as follows:

ACTIVE: Product device recommended for new designs.

LIFEBUY: TI has announced that the device will be discontinued, and a lifetime-buy period is in effect.

NRND: Not recommended for new designs. Device is in production to support existing customers, but TI does not recommend using this part in a new design.

PREVIEW: Device has been announced but is not in production. Samples may or may not be available.

OBSOLETE: TI has discontinued the production of the device.

(2) Eco Plan - The planned eco-friendly classification: Pb-Free (RoHS), Pb-Free (RoHS Exempt), or Green (RoHS & no Sb/Br) - please check <http://www.ti.com/productcontent> for the latest availability information and additional product content details.

TBD: The Pb-Free/Green conversion plan has not been defined.

Pb-Free (RoHS): TI's terms "Lead-Free" or "Pb-Free" mean semiconductor products that are compatible with the current RoHS requirements for all 6 substances, including the requirement that lead not exceed 0.1% by weight in homogeneous materials. Where designed to be soldered at high temperatures, TI Pb-Free products are suitable for use in specified lead-free processes.

Pb-Free (RoHS Exempt): This component has a RoHS exemption for either 1) lead-based flip-chip solder bumps used between the die and package, or 2) lead-based die adhesive used between the die and leadframe. The component is otherwise considered Pb-Free (RoHS compatible) as defined above.

Green (RoHS & no Sb/Br): TI defines "Green" to mean Pb-Free (RoHS compatible), and free of Bromine (Br) and Antimony (Sb) based flame retardants (Br or Sb do not exceed 0.1% by weight in homogeneous material)

(3) MSL, Peak Temp. - The Moisture Sensitivity Level rating according to the JEDEC industry standard classifications, and peak solder temperature.

(4) There may be additional marking, which relates to the logo, the lot trace code information, or the environmental category on the device.

(5) Multiple Device Markings will be inside parentheses. Only one Device Marking contained in parentheses and separated by a "~" will appear on a device. If a line is indented then it is a continuation of the previous line and the two combined represent the entire Device Marking for that device.

(6) Lead/Ball Finish - Orderable Devices may have multiple material finish options. Finish options are separated by a vertical ruled line. Lead/Ball Finish values may wrap to two lines if the finish value exceeds the maximum column width.

Important Information and Disclaimer: The information provided on this page represents TI's knowledge and belief as of the date that it is provided. TI bases its knowledge and belief on information provided by third parties, and makes no representation or warranty as to the accuracy of such information. Efforts are underway to better integrate information from third parties. TI has taken and continues to take reasonable steps to provide representative and accurate information but may not have conducted destructive testing or chemical analysis on incoming materials and chemicals. TI and TI suppliers consider certain information to be proprietary, and thus CAS numbers and other limited information may not be available for release.

In no event shall TI's liability arising out of such information exceed the total purchase price of the TI part(s) at issue in this document sold by TI to Customer on an annual basis.

TAPE AND REEL INFORMATION

REEL DIMENSIONS

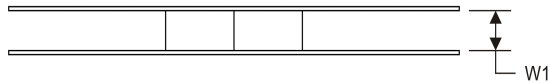
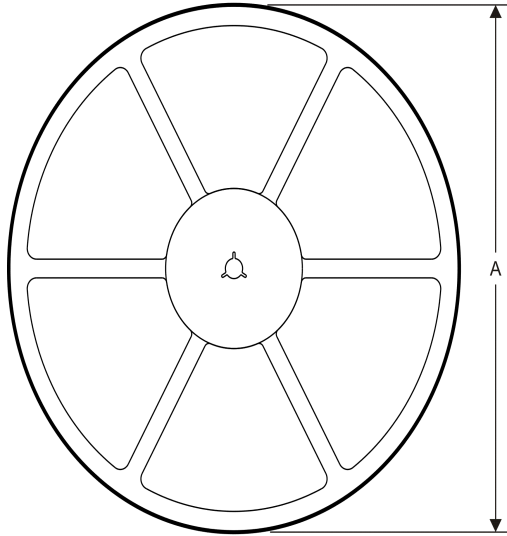

TAPE DIMENSIONS

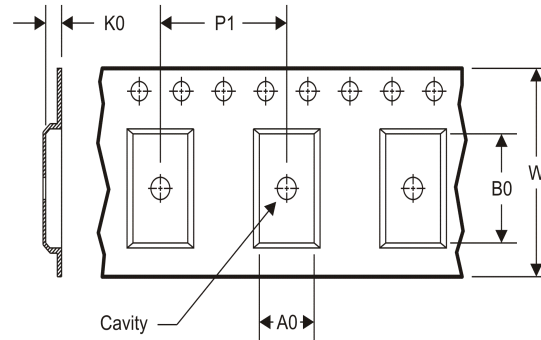

A0	Dimension designed to accommodate the component width
B0	Dimension designed to accommodate the component length
K0	Dimension designed to accommodate the component thickness
W	Overall width of the carrier tape
P1	Pitch between successive cavity centers

TAPE AND REEL INFORMATION

*All dimensions are nominal

Device	Package Type	Package Drawing	Pins	SPQ	Reel Diameter (mm)	Reel Width W1 (mm)	A0 (mm)	B0 (mm)	K0 (mm)	P1 (mm)	W (mm)	Pin1 Quadrant
CY74FCT16500CTPVCT	SSOP	DL	56	1000	330.0	32.4	11.35	18.67	3.1	16.0	32.0	Q1

TAPE AND REEL BOX DIMENSIONS



*All dimensions are nominal

Device	Package Type	Package Drawing	Pins	SPQ	Length (mm)	Width (mm)	Height (mm)
CY74FCT16500CTPVCT	SSOP	DL	56	1000	367.0	367.0	55.0

MECHANICAL DATA

DL (R-PDSO-G56)

PLASTIC SMALL-OUTLINE PACKAGE

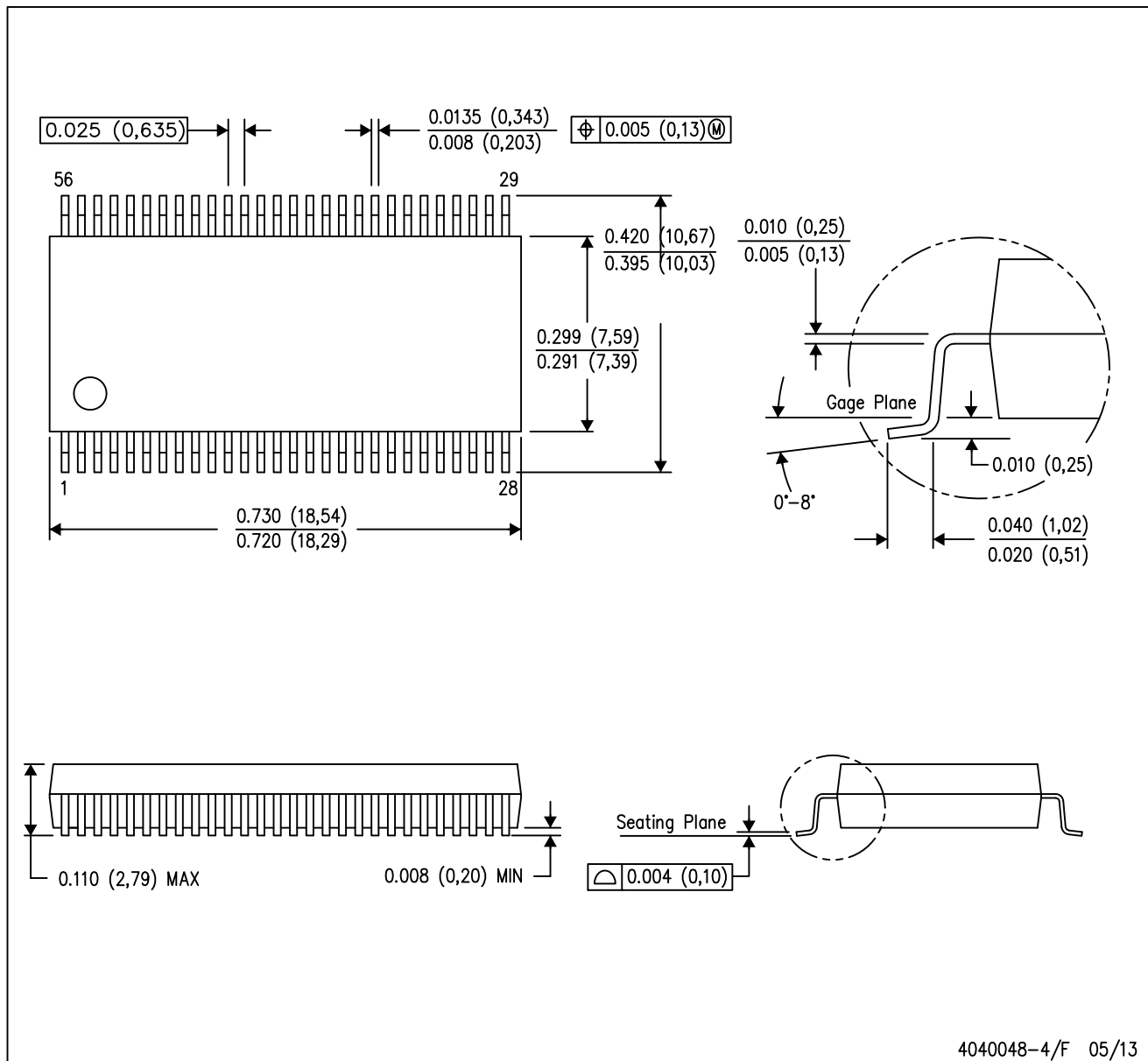

- NOTES:
- All linear dimensions are in inches (millimeters).
 - This drawing is subject to change without notice.
 - Body dimensions do not include mold flash or protrusion not to exceed 0.006 (0,15).
 - Falls within JEDEC MO-118

PowerPAD is a trademark of Texas Instruments.

IMPORTANT NOTICE

Texas Instruments Incorporated and its subsidiaries (TI) reserve the right to make corrections, enhancements, improvements and other changes to its semiconductor products and services per JESD46, latest issue, and to discontinue any product or service per JESD48, latest issue. Buyers should obtain the latest relevant information before placing orders and should verify that such information is current and complete. All semiconductor products (also referred to herein as "components") are sold subject to TI's terms and conditions of sale supplied at the time of order acknowledgment.

TI warrants performance of its components to the specifications applicable at the time of sale, in accordance with the warranty in TI's terms and conditions of sale of semiconductor products. Testing and other quality control techniques are used to the extent TI deems necessary to support this warranty. Except where mandated by applicable law, testing of all parameters of each component is not necessarily performed.

TI assumes no liability for applications assistance or the design of Buyers' products. Buyers are responsible for their products and applications using TI components. To minimize the risks associated with Buyers' products and applications, Buyers should provide adequate design and operating safeguards.

TI does not warrant or represent that any license, either express or implied, is granted under any patent right, copyright, mask work right, or other intellectual property right relating to any combination, machine, or process in which TI components or services are used. Information published by TI regarding third-party products or services does not constitute a license to use such products or services or a warranty or endorsement thereof. Use of such information may require a license from a third party under the patents or other intellectual property of the third party, or a license from TI under the patents or other intellectual property of TI.

Reproduction of significant portions of TI information in TI data books or data sheets is permissible only if reproduction is without alteration and is accompanied by all associated warranties, conditions, limitations, and notices. TI is not responsible or liable for such altered documentation. Information of third parties may be subject to additional restrictions.

Resale of TI components or services with statements different from or beyond the parameters stated by TI for that component or service voids all express and any implied warranties for the associated TI component or service and is an unfair and deceptive business practice. TI is not responsible or liable for any such statements.

Buyer acknowledges and agrees that it is solely responsible for compliance with all legal, regulatory and safety-related requirements concerning its products, and any use of TI components in its applications, notwithstanding any applications-related information or support that may be provided by TI. Buyer represents and agrees that it has all the necessary expertise to create and implement safeguards which anticipate dangerous consequences of failures, monitor failures and their consequences, lessen the likelihood of failures that might cause harm and take appropriate remedial actions. Buyer will fully indemnify TI and its representatives against any damages arising out of the use of any TI components in safety-critical applications.

In some cases, TI components may be promoted specifically to facilitate safety-related applications. With such components, TI's goal is to help enable customers to design and create their own end-product solutions that meet applicable functional safety standards and requirements. Nonetheless, such components are subject to these terms.

No TI components are authorized for use in FDA Class III (or similar life-critical medical equipment) unless authorized officers of the parties have executed a special agreement specifically governing such use.

Only those TI components which TI has specifically designated as military grade or "enhanced plastic" are designed and intended for use in military/aerospace applications or environments. Buyer acknowledges and agrees that any military or aerospace use of TI components which have **not** been so designated is solely at the Buyer's risk, and that Buyer is solely responsible for compliance with all legal and regulatory requirements in connection with such use.

TI has specifically designated certain components as meeting ISO/TS16949 requirements, mainly for automotive use. In any case of use of non-designated products, TI will not be responsible for any failure to meet ISO/TS16949.

Products

Audio	www.ti.com/audio
Amplifiers	amplifier.ti.com
Data Converters	dataconverter.ti.com
DLP® Products	www.dlp.com
DSP	dsp.ti.com
Clocks and Timers	www.ti.com/clocks
Interface	interface.ti.com
Logic	logic.ti.com
Power Mgmt	power.ti.com
Microcontrollers	microcontroller.ti.com
RFID	www.ti-rfid.com
OMAP Applications Processors	www.ti.com/omap
Wireless Connectivity	www.ti.com/wirelessconnectivity

Applications

Automotive and Transportation	www.ti.com/automotive
Communications and Telecom	www.ti.com/communications
Computers and Peripherals	www.ti.com/computers
Consumer Electronics	www.ti.com/consumer-apps
Energy and Lighting	www.ti.com/energy
Industrial	www.ti.com/industrial
Medical	www.ti.com/medical
Security	www.ti.com/security
Space, Avionics and Defense	www.ti.com/space-avionics-defense
Video and Imaging	www.ti.com/video

TI E2E Community

e2e.ti.com