

## Features

- Pin and function compatible with CY7C1049CV33
- High speed
  - $t_{AA} = 10 \text{ ns}$
- Low active power
  - $I_{CC} = 90 \text{ mA}$  at 10 ns
- Low CMOS standby power
  - $I_{SB2} = 10 \text{ mA}$
- 2.0 V data retention
- Automatic power down when deselected
- TTL compatible inputs and outputs
- Easy memory expansion with  $\overline{CE}$  and  $\overline{OE}$  features
- Available in Pb-free 36-pin (400 Mil) molded SOJ and 44-pin TSOP II packages

## Functional Description

The CY7C1049DV33 is a high performance CMOS Static RAM organized as 512K words by 8-bits. Easy memory expansion is provided by an Active LOW Chip Enable ( $\overline{CE}$ ), an Active LOW Output Enable ( $\overline{OE}$ ), and tristate drivers. You can write to the device by taking Chip Enable ( $\overline{CE}$ ) and Write Enable ( $\overline{WE}$ ) inputs LOW. Data on the eight I/O pins ( $IO_0$  through  $IO_7$ ) is then written into the location specified on the address pins ( $A_0$  through  $A_{18}$ ).

You can read from the device by taking Chip Enable ( $\overline{CE}$ ) and Output Enable ( $\overline{OE}$ ) LOW while forcing Write Enable ( $\overline{WE}$ ) HIGH. Under these conditions, the contents of the memory location specified by the address pins appear on the I/O pins.

The eight input or output pins ( $IO_0$  through  $IO_7$ ) are placed in a high impedance state when the device is deselected ( $\overline{CE}$  HIGH), the outputs are disabled ( $\overline{OE}$  HIGH), or during a write operation ( $\overline{CE}$  LOW, and  $\overline{WE}$  LOW).

The CY7C1049DV33 is available in standard 400 Mil wide 36-pin SOJ package and 44-pin TSOP II package with center power and ground (revolutionary) pinout.

For a complete list of related documentation, [click here](#).

## Logic Block Diagram

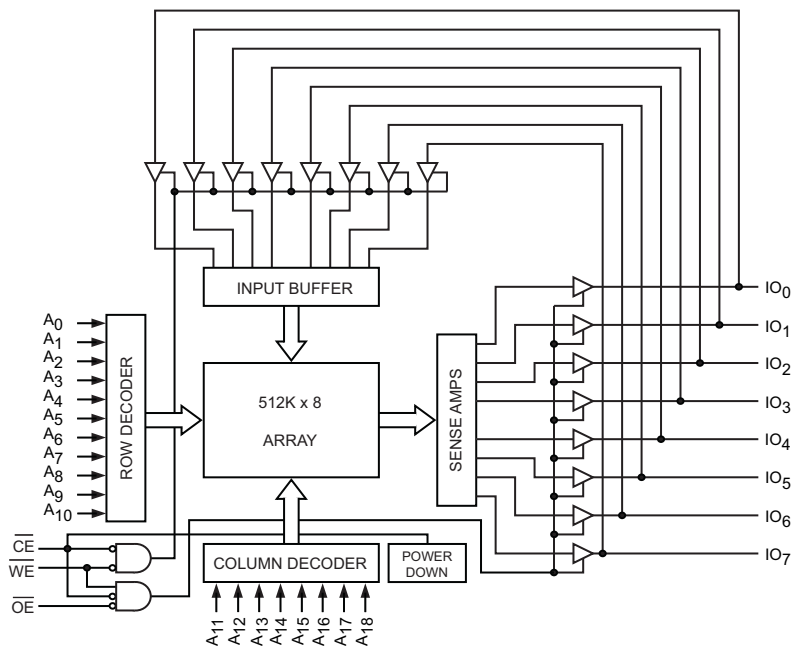

## Contents

<b>Pin Configuration</b> .....	<b>3</b>	<b>Ordering Information</b> .....	<b>9</b>
<b>Selection Guide</b> .....	<b>3</b>	Ordering Code Definitions .....	9
<b>Maximum Ratings</b> .....	<b>4</b>	<b>Package Diagrams</b> .....	<b>10</b>
<b>Operating Range</b> .....	<b>4</b>	<b>Acronyms</b> .....	<b>12</b>
<b>Electrical Characteristics</b> .....	<b>4</b>	<b>Document Conventions</b> .....	<b>12</b>
<b>Capacitance</b> .....	<b>4</b>	Units of Measure .....	12
<b>Thermal Resistance</b> .....	<b>5</b>	<b>Document History Page</b> .....	<b>13</b>
<b>AC Test Loads and Waveforms</b> .....	<b>5</b>	<b>Sales, Solutions, and Legal Information</b> .....	<b>14</b>
<b>Data Retention Characteristics</b> .....	<b>5</b>	Worldwide Sales and Design Support .....	14
<b>AC Switching Characteristics</b> .....	<b>6</b>	Products .....	14
<b>Switching Waveforms</b> .....	<b>7</b>	PSoC Solutions .....	14
<b>Truth Table</b> .....	<b>9</b>		

**Pin Configuration**

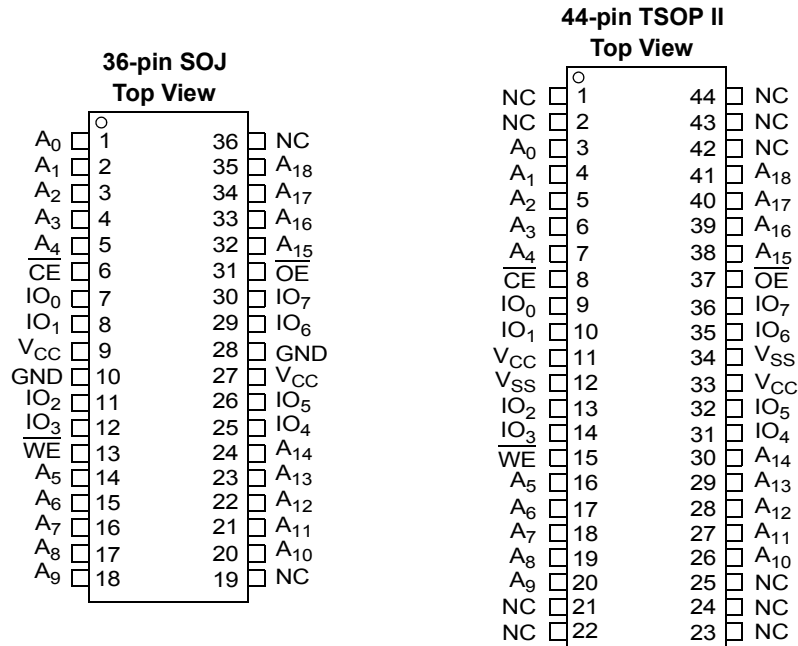

**Selection Guide**

Description	-10 (Industrial)	Unit
Maximum access time	10	ns
Maximum operating current	90	mA
Maximum CMOS standby current	10	mA

## Maximum Ratings

Exceeding the maximum ratings may impair the useful life of the device. User guidelines are not tested.

Storage temperature .....	-65 °C to +150 °C
Ambient temperature with power applied .....	-55 °C to +125 °C
Supply voltage on $V_{CC}$ to relative GND <sup>[1]</sup> .....	-0.3 V to +4.6 V
DC voltage applied to outputs in High Z State <sup>[1]</sup> .....	-0.3 V to $V_{CC} + 0.3$ V

DC input voltage <sup>[1]</sup> .....	-0.3 V to $V_{CC} + 0.3$ V
Current into outputs (LOW) .....	20 mA
Static discharge voltage .....	> 2001 V (MIL-STD-883, Method 3015)
Latch up current .....	> 200 mA

## Operating Range

Range	Ambient Temperature	$V_{CC}$	Speed
Industrial	-40 °C to +85 °C	3.3 V ± 0.3 V	10 ns

## Electrical Characteristics

Over the Operating Range

Parameter	Description	Test Conditions	-10 (Industrial)		Unit	
			Min	Max		
$V_{OH}$	Output HIGH voltage	$V_{CC} = \text{Min}, I_{OH} = -4.0 \text{ mA}$	2.4	–	V	
$V_{OL}$	Output LOW voltage	$V_{CC} = \text{Min}, I_{OL} = 8.0 \text{ mA}$	–	0.4	V	
$V_{IH}$ <sup>[1]</sup>	Input HIGH voltage		2.0	$V_{CC} + 0.3$	V	
$V_{IL}$ <sup>[1]</sup>	Input LOW voltage <sup>[1]</sup>		-0.3	0.8	V	
$I_{IX}$	Input leakage current	$GND \leq V_I \leq V_{CC}$	-1	+1	µA	
$I_{OZ}$	Output leakage current	$GND \leq V_{OUT} \leq V_{CC}$ , Output Disabled	-1	+1	µA	
$I_{CC}$	$V_{CC}$ operating supply current	$V_{CC} = \text{Max},$ $f = f_{MAX} = 1/t_{RC}$	100 MHz	–	90	mA
			83 MHz	–	80	mA
			66 MHz	–	70	mA
			40 MHz	–	60	mA
$I_{SB1}$	Automatic CE Power down current —TTL Inputs	Max $V_{CC}$ , $\overline{CE} \geq V_{IH}$ ; $V_{IN} \geq V_{IH}$ or $V_{IN} \leq V_{IL}$ , $f = f_{MAX}$	–	20	mA	
$I_{SB2}$	Automatic CE Power down current —CMOS Inputs	Max $V_{CC}$ , $\overline{CE} \geq V_{CC} - 0.3 \text{ V}$ , $V_{IN} \geq V_{CC} - 0.3 \text{ V}$ , or $V_{IN} \leq 0.3 \text{ V}$ , $f = 0$	–	10	mA	

## Capacitance

Tested initially and after any design or process changes that may affect these parameters.

Parameter	Description	Test Conditions	Max	Unit
$C_{IN}$	Input capacitance	$T_A = 25 \text{ °C}, f = 1 \text{ MHz}, V_{CC} = 3.3 \text{ V}$	8	pF
$C_{OUT}$	I/O capacitance		8	pF

### Note

- $V_{IL}(\text{min.}) = -2.0 \text{ V}$  and  $V_{IH}(\text{max.}) = V_{CC} + 2 \text{ V}$  for pulse durations of less than 20 ns.

## Thermal Resistance

Tested initially and after any design or process changes that may affect these parameters.

Parameter	Description	Test Conditions	36-pin SOJ Package	44-pin TSOP II Package	Unit
$\Theta_{JA}$	Thermal resistance (Junction to Ambient)	Still Air, soldered on a 3 × 4.5 inch, two layer printed circuit board	57.91	50.66	°C/W
$\Theta_{JC}$	Thermal resistance (Junction to Case)		36.73	17.17	°C/W

## AC Test Loads and Waveforms

Figure 1. AC Test Loads and Waveforms [4]

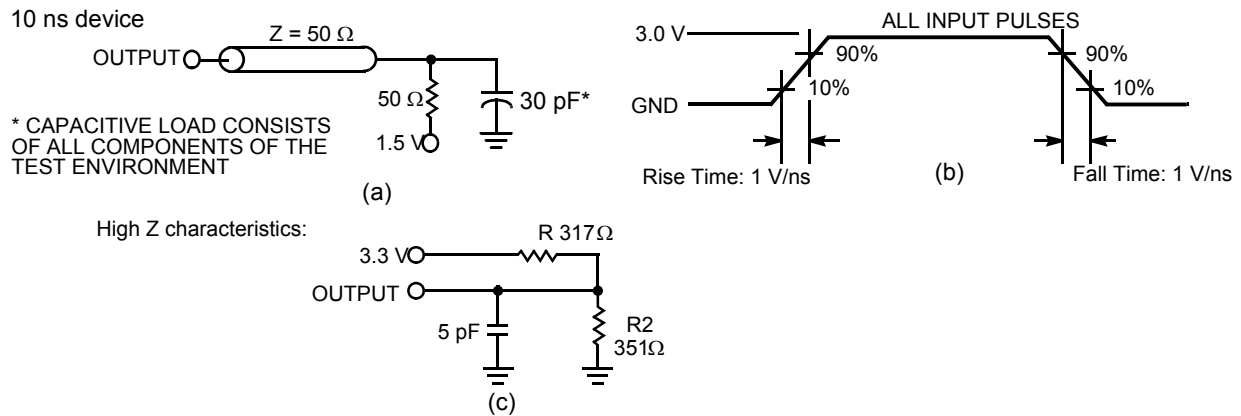

## Data Retention Characteristics

Over the Operating Range

Parameter	Description	Conditions [4]	Min	Max	Unit
$V_{DR}$	$V_{CC}$ for data retention		2.0	–	V
$I_{CCDR}$	Data retention current	$V_{CC} = V_{DR} = 2.0 \text{ V}$ , $CE \geq V_{CC} - 0.3 \text{ V}$ $V_{IN} \geq V_{CC} - 0.3 \text{ V}$ or $V_{IN} \leq 0.3 \text{ V}$	–	10	mA
$t_{CDR}^{[2]}$	Chip deselect to data retention time		0	–	ns
$t_R^{[5]}$	Operation recovery time		$t_{RC}$	–	ns

Figure 2. Data Retention Waveform

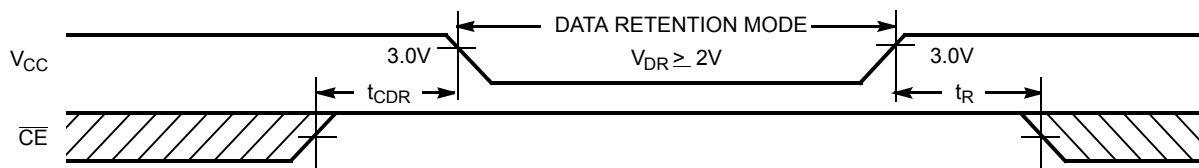

### Notes

- Tested initially and after any design or process changes that may affect these parameters.
- AC characteristics (except High Z) are tested using the load conditions shown in Figure 1 (a). High Z characteristics are tested for all speeds using the test load shown in Figure 1 (c).
- No input may exceed  $V_{CC} + 0.3 \text{ V}$ .
- Full device operation requires linear  $V_{CC}$  ramp from  $V_{DR}$  to  $V_{CC(min.)} \geq 50 \mu\text{s}$  or stable at  $V_{CC(min.)} \geq 50 \mu\text{s}$ .

## AC Switching Characteristics

Over the Operating Range <sup>[6]</sup>

Parameter	Description	-10 (Industrial)		Unit
		Min	Max	
<b>Read Cycle</b>				
$t_{power}^{[7]}$	$V_{CC}$ (typical) to the first access	100	–	$\mu$ s
$t_{RC}$	Read cycle time	10	–	ns
$t_{AA}$	Address to data valid	–	10	ns
$t_{OHA}$	Data hold from address change	3	–	ns
$t_{ACE}$	$\overline{CE}$ LOW to data valid	–	10	ns
$t_{DOE}$	$\overline{OE}$ LOW to data valid	–	5	ns
$t_{LZOE}$	$\overline{OE}$ LOW to Low Z <sup>[8]</sup>	0	–	ns
$t_{HZOE}$	$\overline{OE}$ HIGH to High Z <sup>[8, 9]</sup>	–	5	ns
$t_{LZCE}$	$\overline{CE}$ LOW to Low Z <sup>[8]</sup>	3	–	ns
$t_{HZCE}$	$\overline{CE}$ HIGH to High Z <sup>[8, 9]</sup>	–	5	ns
$t_{PU}$	$\overline{CE}$ LOW to power up	0	–	ns
$t_{PD}$	$\overline{CE}$ HIGH to power down	–	10	ns
<b>Write Cycle<sup>[10, 11]</sup></b>				
$t_{WC}$	Write cycle time	10	–	ns
$t_{SCE}$	$\overline{CE}$ LOW to write end	7	–	ns
$t_{AW}$	Address setup to write end	7	–	ns
$t_{HA}$	Address hold from write end	0	–	ns
$t_{SA}$	Address setup to write start	0	–	ns
$t_{PWE}$	$\overline{WE}$ pulse width	7	–	ns
$t_{SD}$	Data setup to write end	5	–	ns
$t_{HD}$	Data hold from write end	0	–	ns
$t_{LZWE}$	$\overline{WE}$ HIGH to Low Z <sup>[8]</sup>	3	–	ns
$t_{HZWE}$	$\overline{WE}$ LOW to High Z <sup>[8, 9]</sup>	–	5	ns

### Notes

6. Test conditions assume signal transition time of 3 ns or less, timing reference levels of 1.5 V, input pulse levels of 0 to 3.0 V, and output loading of the specified  $I_{OL}/I_{OH}$  and 30 pF load capacitance.
7.  $t_{POWER}$  gives the minimum amount of time that the power supply must be at stable, typical  $V_{CC}$  values until the first memory access is performed.
8. At any temperature and voltage condition,  $t_{HZCE}$  is less than  $t_{LZCE}$ ,  $t_{HZOE}$  is less than  $t_{LZOE}$ , and  $t_{HZWE}$  is less than  $t_{LZWE}$  for any given device.
9.  $t_{HZOE}$ ,  $t_{HZCE}$ , and  $t_{HZWE}$  are specified with a load capacitance of 5 pF as in part (c) of [Figure 1 on page 5](#). Transition is measured when the outputs enter a high impedance state.
10. The internal write time of the memory is defined by the overlap of  $\overline{CE}$  LOW, and  $\overline{WE}$  LOW.  $\overline{CE}$  and  $\overline{WE}$  must be LOW to initiate a write, and the transition of either of these signals can terminate the write. The input data set up and hold timing must be referred to the leading edge of the signal that terminates the write.
11. The minimum write cycle time for Write Cycle No. 2 ( $\overline{WE}$  controlled,  $\overline{OE}$  LOW) is the sum of  $t_{HZWE}$  and  $t_{SD}$ .

### Switching Waveforms

Figure 3. Read Cycle No. 1<sup>[12, 13]</sup>

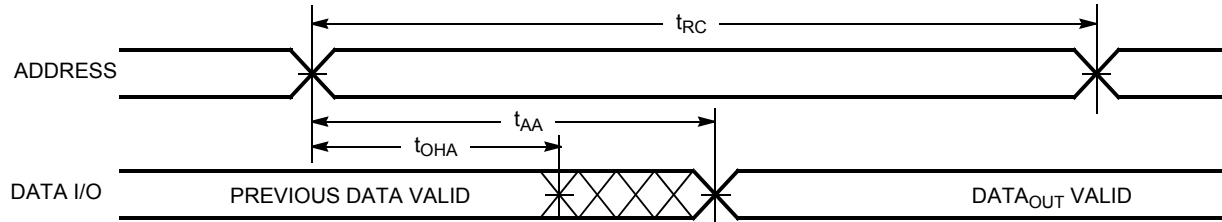

Figure 4. Read Cycle No. 2 ( $\overline{OE}$  Controlled)<sup>[13, 14]</sup>

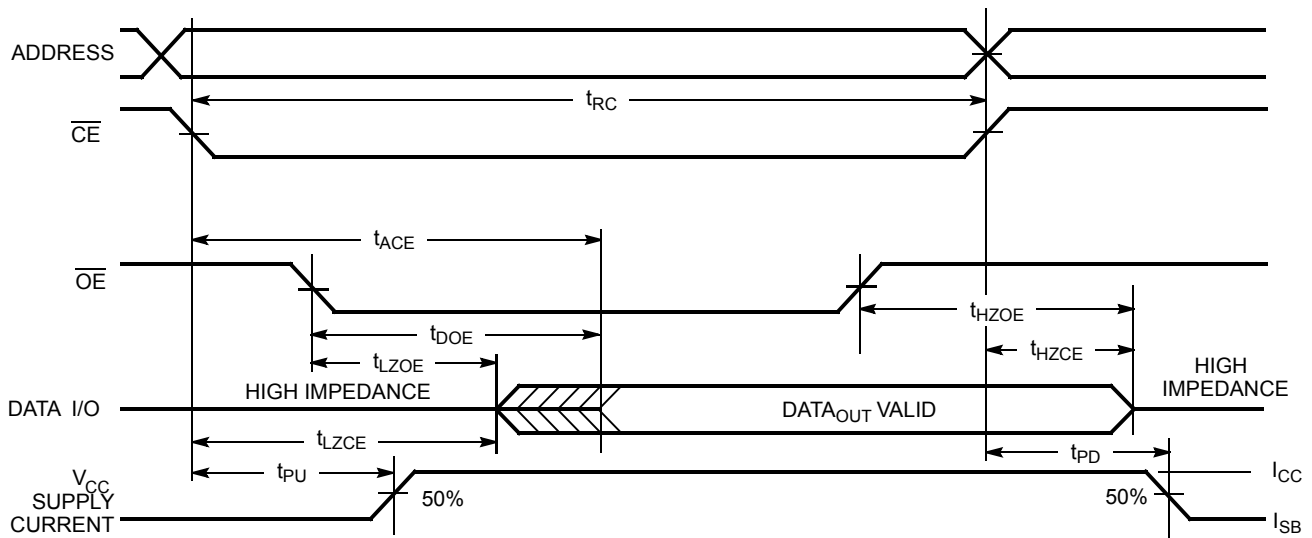
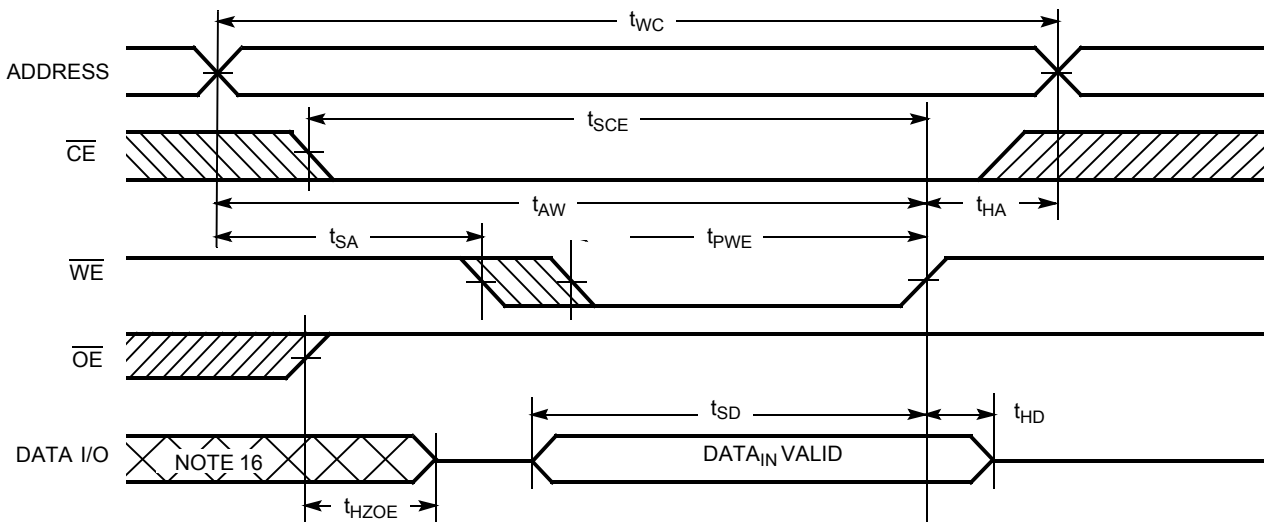

Figure 5. Write Cycle No. 1 ( $\overline{WE}$  Controlled,  $\overline{OE}$  HIGH During Write)<sup>[15, 16]</sup>



**Notes**

- 12. Device is continuously selected.  $\overline{OE}, \overline{CE} = V_{IL}$ .
- 13. WE is HIGH for read cycle.
- 14. Address valid prior to or coincident with  $\overline{CE}$  transition LOW.
- 15. Data I/O is high impedance if  $\overline{OE} = V_{IH}$ .
- 16. If CE goes HIGH simultaneously with WE going HIGH, the output remains in a high impedance state.

Switching Waveforms (continued)

Figure 6. Write Cycle No. 2 ( $\overline{WE}$  Controlled,  $\overline{OE}$  LOW)<sup>[17]</sup>

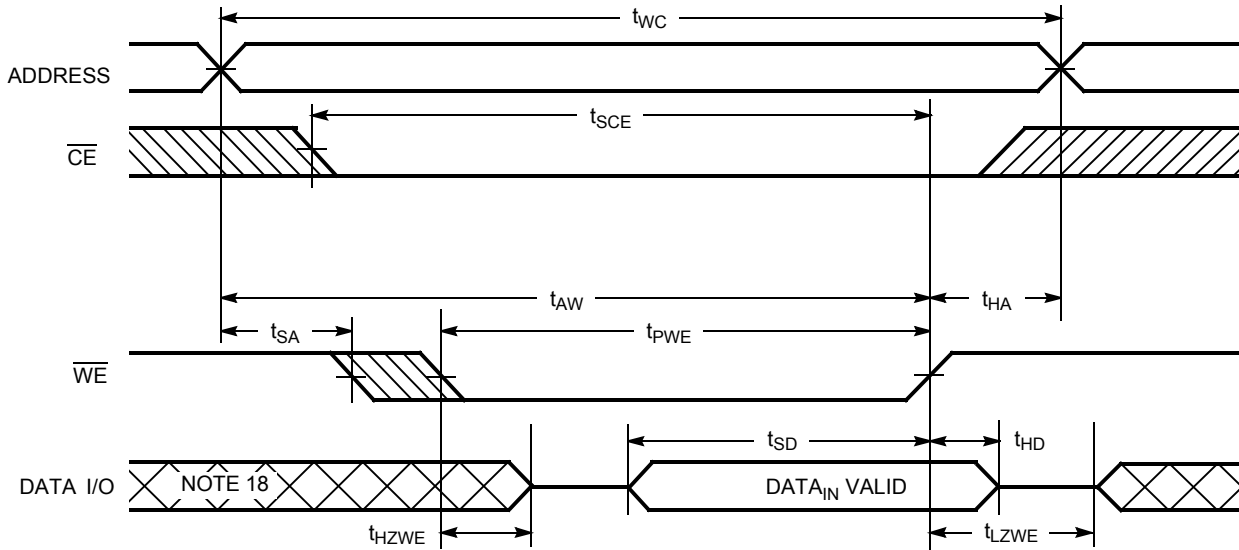
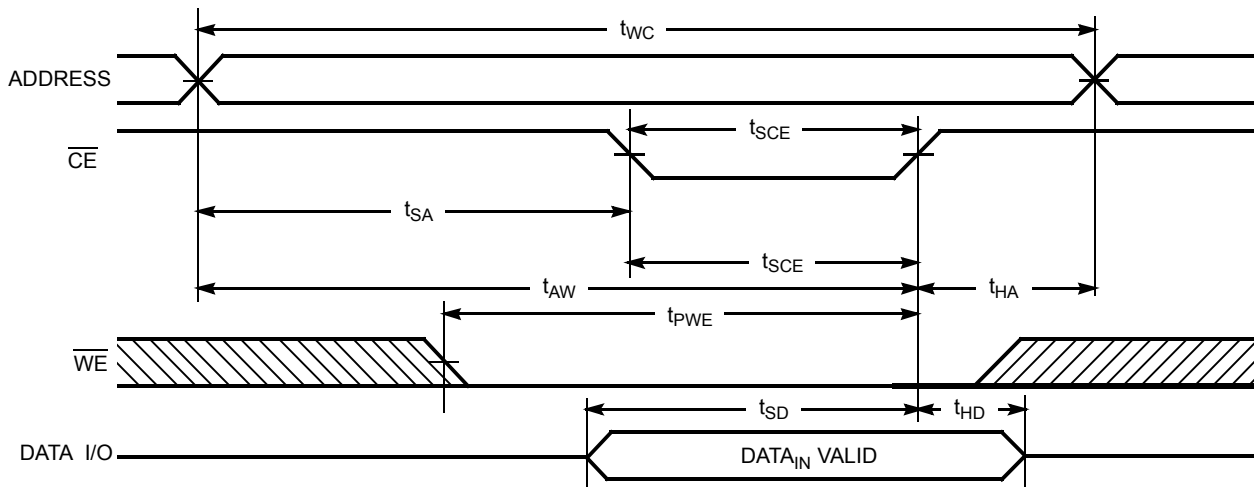

Figure 7. Write Cycle No. 3 ( $\overline{CE}$  Controlled)<sup>[17, 19]</sup>



Notes

- 17. If  $\overline{CE}$  goes HIGH simultaneously with  $\overline{WE}$  going HIGH, the output remains in a high impedance state.
- 18. During this period the I/Os are in the output state and input signals must not be applied.
- 19. Data I/O is high impedance if  $\overline{OE} = V_{IH}$ .

**Truth Table**

$\overline{CE}$	$\overline{OE}$	$\overline{WE}$	$IO_0$ - $IO_7$	Mode	Power
H	X	X	High Z	Power down	Standby ( $I_{SB}$ )
L	L	H	Data Out	Read	Active ( $I_{CC}$ )
L	X	L	Data In	Write	Active ( $I_{CC}$ )
L	H	H	High Z	Selected, Outputs Disabled	Active ( $I_{CC}$ )

**Ordering Information**

Speed (ns)	Ordering Code	Package Name	Package Type	Operating Range
10	CY7C1049DV33-10VXI	51-85090	36-pin (400-Mil) Molded SOJ (Pb-free)	Industrial
	CY7C1049DV33-10ZSXI	51-85087	44-pin TSOP II (Pb-free)	

Contact your local Cypress sales representative for availability of these parts.

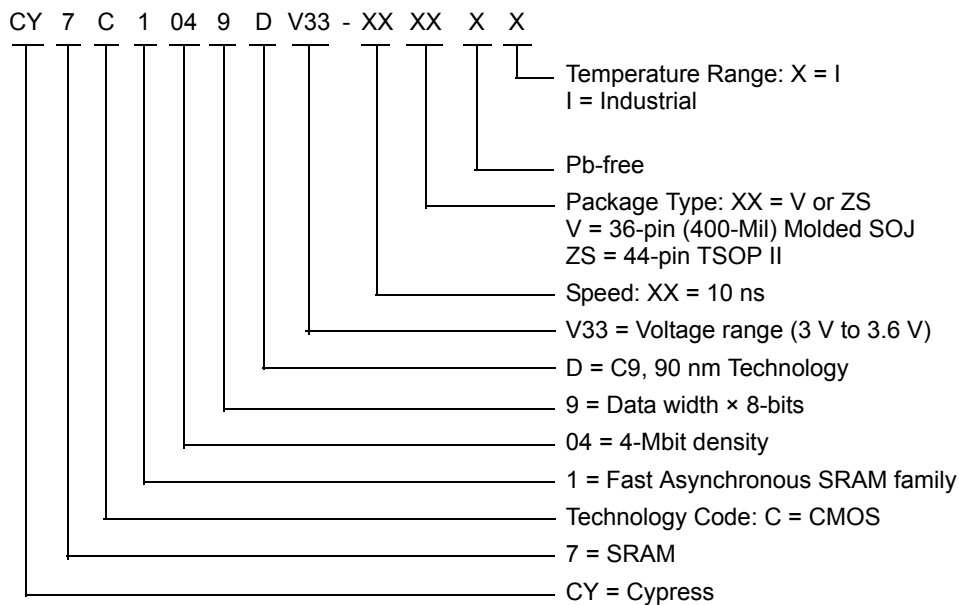
**Ordering Code Definitions**

Package Diagrams

Figure 8. 36-pin (400-Mil) Molded SOJ V36.4, (51-85090)

36 Lead (400 MIL) Molded SOJ V36

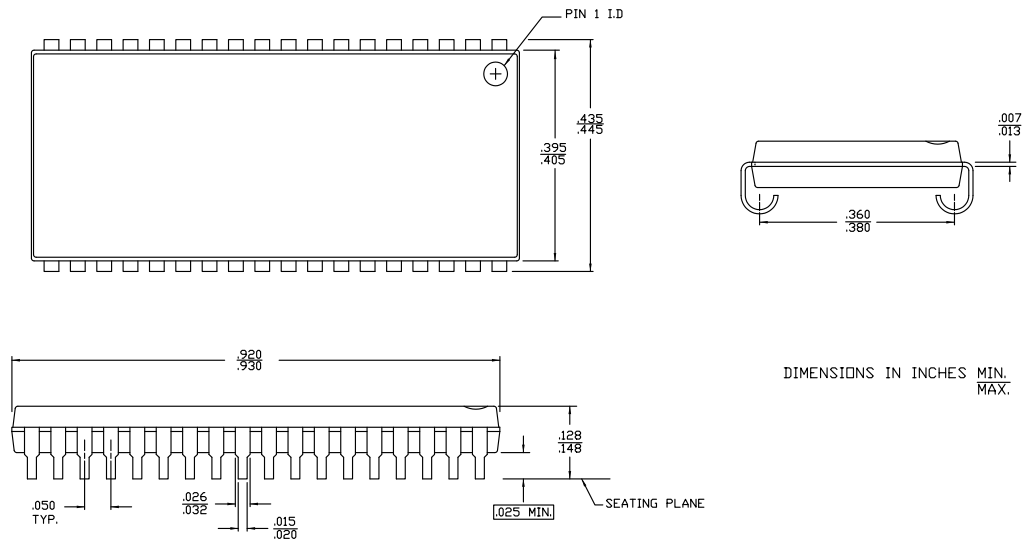

51-85090 \*F

Package Diagrams (continued)

Figure 9. 44-pin TSOP Z44-II, (51-85087)

44 Lead TSOP TYPE II – STANDARD

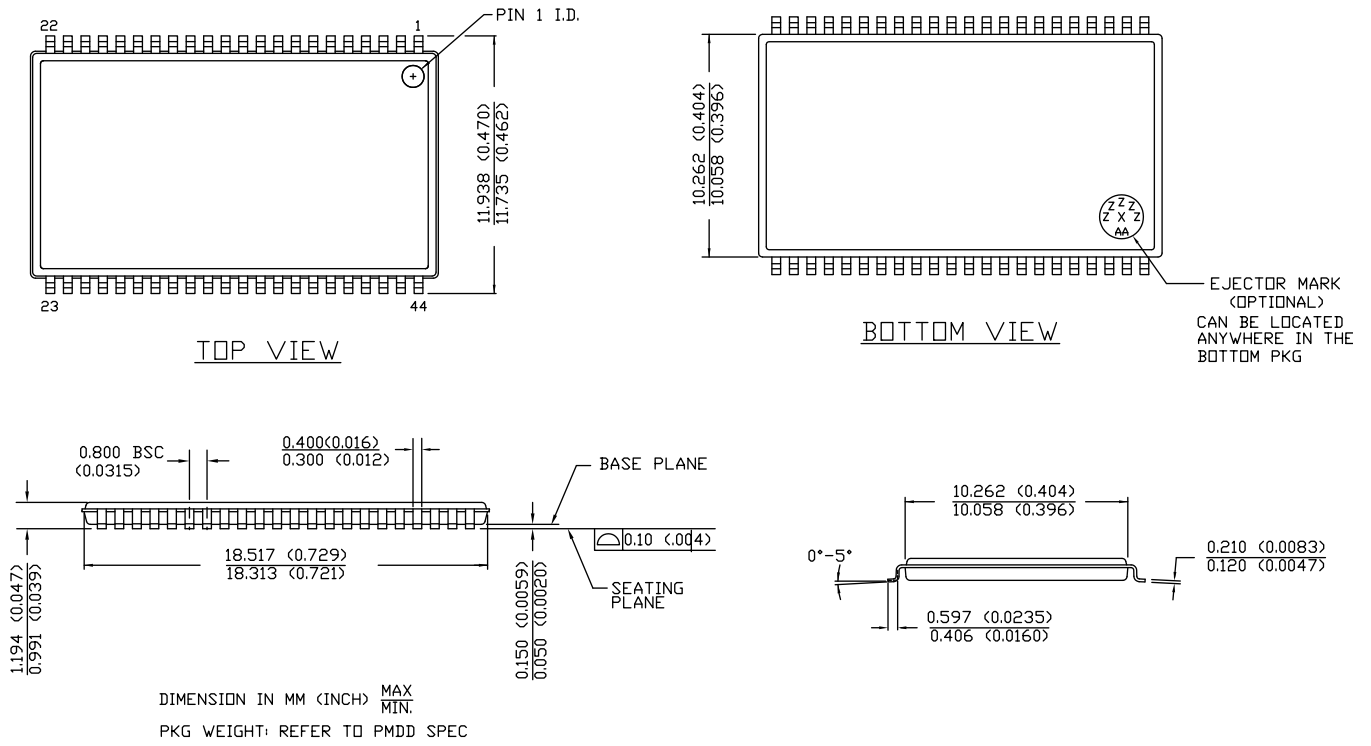

51-85087 \*E

## Acronyms

Acronym	Description
$\overline{CE}$	chip enable
CMOS	complementary metal oxide semiconductor
I/O	input/output
$\overline{OE}$	output enable
SOJ	small outline J-lead
SRAM	static random access memory
TSOP	thin small outline package
TTL	transistor-transistor logic
$\overline{WE}$	write enable

## Document Conventions

### Units of Measure

Symbol	Unit of Measure
°C	degree Celcius
MHz	megahertz
μA	microamperes
μs	microseconds
mA	milliamperes
mm	millimeter
ms	milliseconds
ns	nanoseconds
Ω	ohms
%	percent
pF	pico Farad
V	Volts
W	Watts

**Document History Page**

Document Title: CY7C1049DV33, 4-Mbit (512 K × 8) Static RAM				
Document Number: 38-05475				
REV.	ECN NO.	Issue Date	Orig. of Change	Description of Change
**	201560	See ECN	SWI	Advance Datasheet for C9 IPP
*A	233729	See ECN	SYT	1.AC, DC parameters are modified as per EROS (Specification # 01-2165) 2.Pb-free offering in the Ordering Information Table
*B	351096	See ECN	PCI	Changed from Advance to Preliminary Removed 20 ns Speed bin Corrected DC voltage (min) value in maximum ratings section from - 0.5 to - 0.3V Redefined I <sub>CC</sub> values for Com'l and Ind'l temperature ranges I <sub>CC</sub> (Com'l): Changed from 100, 80, and 67 mA to 90, 80 and, 75 mA for 8, 10, and 12ns speed bins respectively I <sub>CC</sub> (Ind'l): Changed from 80 and 67 mA to 90 and 85 mA for 10 and 12ns speed bins respectively Added V <sub>IH(max)</sub> specification in Note# 2 Changed reference voltage level for measurement of High Z parameters from ±500 mV to ±200 mV Added Data Retention Characteristics, Waveform, and footnotes 11 and 12 Changed Package Diagram name from 44-pin TSOP II Z44 to 44-pin TSOP II ZS44 Changed part names from Z to ZS in the Ordering Information Table Added 8 ns parts in the Ordering Information Table Added Pb-free Ordering Information Shaded Ordering Information Table
*C	446328	See ECN	NXR	Converted from Preliminary to Final Removed -8 speed bin Removed Commercial Operating Range product information Added Automotive Operating Range product information Updated Thermal Resistance table Updated footnote #8 on High Z parameter measurement Replaced Package Name column with Package Diagram in the Ordering Information table
*D	1274726	See ECN	VKN/AESA	Corrected typo in the 44-Pin TSOP II pinout
*E	2899972	03/29/2010	AJU	Updated <a href="#">Package Diagrams</a> .
*F	3059162	10/14/2010	PRAS	Added <a href="#">Ordering Code Definitions</a> . Updated <a href="#">Package Diagrams</a> .
*G	3266084	05/28/2011	PRAS	Updated <a href="#">Functional Description</a> (Removed "Refer to the Cypress application note AN1064, SRAM System Guidelines for best practice recommendations."). Added <a href="#">Acronyms</a> and <a href="#">Units of Measure</a> . Updated in new template.
*H	3440302	11/16/2011	TAVA	Removed automotive part information from the datasheet. Updated read and write waveforms.
*I	4574311	11/19/2014	TAVA	Added related documentation hyperlink in page 1. Updated <a href="#">Figure 8</a> in <a href="#">Package Diagrams</a> (spec 51-85090 *E to *F).

## Sales, Solutions, and Legal Information

### Worldwide Sales and Design Support

Cypress maintains a worldwide network of offices, solution centers, manufacturer's representatives, and distributors. To find the office closest to you, visit us at [Cypress Locations](#).

### Products

Automotive	<a href="http://cypress.com/go/automotive">cypress.com/go/automotive</a>
Clocks & Buffers	<a href="http://cypress.com/go/clocks">cypress.com/go/clocks</a>
Interface	<a href="http://cypress.com/go/interface">cypress.com/go/interface</a>
Lighting & Power Control	<a href="http://cypress.com/go/powerpsoc">cypress.com/go/powerpsoc</a> <a href="http://cypress.com/go/plc">cypress.com/go/plc</a>
Memory	<a href="http://cypress.com/go/memory">cypress.com/go/memory</a>
Optical & Image Sensing	<a href="http://cypress.com/go/image">cypress.com/go/image</a>
PSoC	<a href="http://cypress.com/go/psoc">cypress.com/go/psoc</a>
Touch Sensing	<a href="http://cypress.com/go/touch">cypress.com/go/touch</a>
USB Controllers	<a href="http://cypress.com/go/USB">cypress.com/go/USB</a>
Wireless/RF	<a href="http://cypress.com/go/wireless">cypress.com/go/wireless</a>

### PSoC Solutions

[psoc.cypress.com/solutions](http://psoc.cypress.com/solutions)  
PSoC 1 | PSoC 3 | PSoC 5

---

© Cypress Semiconductor Corporation, 2004-2014. The information contained herein is subject to change without notice. Cypress Semiconductor Corporation assumes no responsibility for the use of any circuitry other than circuitry embodied in a Cypress product. Nor does it convey or imply any license under patent or other rights. Cypress products are not warranted nor intended to be used for medical, life support, life saving, critical control or safety applications, unless pursuant to an express written agreement with Cypress. Furthermore, Cypress does not authorize its products for use as critical components in life-support systems where a malfunction or failure may reasonably be expected to result in significant injury to the user. The inclusion of Cypress products in life-support systems application implies that the manufacturer assumes all risk of such use and in doing so indemnifies Cypress against all charges.

Any Source Code (software and/or firmware) is owned by Cypress Semiconductor Corporation (Cypress) and is protected by and subject to worldwide patent protection (United States and foreign), United States copyright laws and international treaty provisions. Cypress hereby grants to licensee a personal, non-exclusive, non-transferable license to copy, use, modify, create derivative works of, and compile the Cypress Source Code and derivative works for the sole purpose of creating custom software and or firmware in support of licensee product to be used only in conjunction with a Cypress integrated circuit as specified in the applicable agreement. Any reproduction, modification, translation, compilation, or representation of this Source Code except as specified above is prohibited without the express written permission of Cypress.

Disclaimer: CYPRESS MAKES NO WARRANTY OF ANY KIND, EXPRESS OR IMPLIED, WITH REGARD TO THIS MATERIAL, INCLUDING, BUT NOT LIMITED TO, THE IMPLIED WARRANTIES OF MERCHANTABILITY AND FITNESS FOR A PARTICULAR PURPOSE. Cypress reserves the right to make changes without further notice to the materials described herein. Cypress does not assume any liability arising out of the application or use of any product or circuit described herein. Cypress does not authorize its products for use as critical components in life-support systems where a malfunction or failure may reasonably be expected to result in significant injury to the user. The inclusion of Cypress' product in a life-support systems application implies that the manufacturer assumes all risk of such use and in doing so indemnifies Cypress against all charges.

Use may be limited by and subject to the applicable Cypress software license agreement.