



18-Bit, Single-Channel, Low-Noise, Voltage-Output DIGITAL-TO-ANALOG CONVERTER

FEATURES

- **18-Bit Monotonic Over Temperature Range**
- **Relative Accuracy: $\pm 2\text{LSB Max}$**
- **Low-Noise: $24\text{nV}/\sqrt{\text{Hz}}$**
- **Fast Settling: $5\mu\text{s}$**
- **On-Chip Output Buffer Amplifier with Rail-to-Rail Operation**
- **Single Power Supply: $+2.7\text{V}$ to $+5.5\text{V}$**
- **DAC Loading Control**
- **Selectable Power-On Reset to Zero-Scale or Midscale**
- **Power-Down Mode**
- **Unipolar Straight Binary or Twos Complement Input Mode**
- **Fast SPI™ Interface with Schmitt-Triggered Inputs: up to 50MHz, 1.8V/3V/5V Logic**
- **Small Package: QFN-24, 4mm x 4mm**

APPLICATIONS

- **Automatic Test Equipment**
- **Precision Instrumentation**
- **Industrial Control**
- **Data Acquisition Systems**

DESCRIPTION

The DAC9881 is an 18-bit, single-channel, voltage-output digital-to-analog converter (DAC). It features 18-bit monotonicity, excellent linearity, very low-noise, and fast settling time. The on-chip precision output amplifier allows rail-to-rail output swing to be achieved over the full supply range of 2.7V to 5.5V.

The device supports a standard SPI serial interface capable of operating with input data clock frequencies up to 50MHz. The DAC9881 requires an external reference voltage to set the output range of the DAC channel. A programmable power-on reset circuit is also incorporated into the device to ensure that the DAC output powers up at zero-scale or midscale, and remains there until a valid write command.

Additionally, the DAC9881 has the capability to function in either unipolar straight binary or twos complement mode. The DAC9881 provides low-power operation. To further save energy, power-down mode can be achieved by accessing the PDN pin, thereby reducing the current consumption to 25 μA at 5V. Power consumption is 4mW at 5V, reducing to 125 μW in power-down mode.

The DAC9881 is available in a 4mm x 4mm QFN-24 package with a specified temperature range of -40°C to $+105^{\circ}\text{C}$.

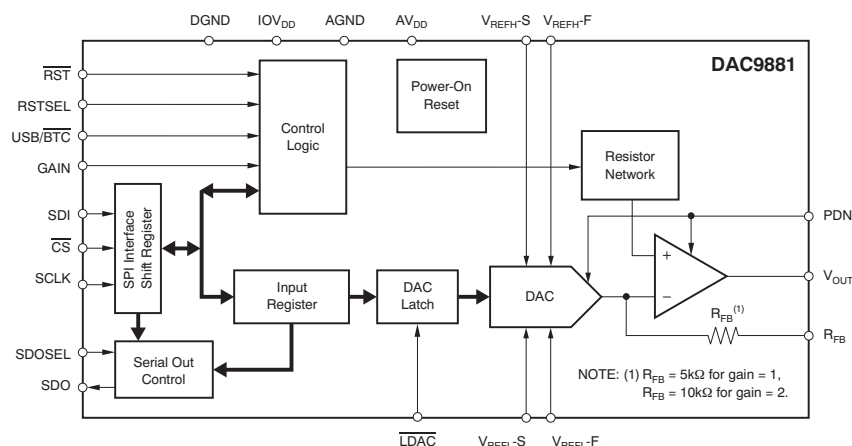

Please be aware that an important notice concerning availability, standard warranty, and use in critical applications of Texas Instruments semiconductor products and disclaimers thereto appears at the end of this data sheet.

SPI, QSPI are trademarks of Motorola, Inc.

MICROWIRE is a trademark of National Semiconductor.

All other trademarks are the property of their respective owners.



This integrated circuit can be damaged by ESD. Texas Instruments recommends that all integrated circuits be handled with appropriate precautions. Failure to observe proper handling and installation procedures can cause damage.

ESD damage can range from subtle performance degradation to complete device failure. Precision integrated circuits may be more susceptible to damage because very small parametric changes could cause the device not to meet its published specifications.

ORDERING INFORMATION⁽¹⁾

PRODUCT	RELATIVE ACCURACY (LSB)	DIFFERENTIAL NONLINEARITY (LSB)	PACKAGE-LEAD	PACKAGE DESIGNATOR	SPECIFIED TEMPERATURE RANGE	PACKAGE MARKING
DAC9881S	±3	-1/+2	QFN-24	RGE	-40°C to +105°C	DAC9881
DAC9881SB	±2	±1	QFN-24	RGE	-40°C to +105°C	DAC9881B

(1) For the most current package and ordering information, see the Package Option Addendum at the end of this data sheet, or see the TI website at www.ti.com.

ABSOLUTE MAXIMUM RATINGS⁽¹⁾

Over operating free-air temperature range (unless otherwise noted).

PARAMETER	DAC9881	UNIT
AV_{DD} to AGND	-0.3 to 6	V
IOV_{DD} to DGND	-0.3 to 6	V
Digital input voltage to DGND	-0.3 to $IOV_{DD} + 0.3$	V
V_{OUT} to AGND	-0.3 to $AV_{DD} + 0.3$	V
Operating temperature range	-40 to +105	°C
Storage temperature range	-65 to +150	°C
Maximum junction temperature (T_J max)	+150	°C
Thermal impedance (θ_{JA})	46	°C/W
ESD ratings	Human body model (HBM)	3000
	Charged device model (CDM)	1000

(1) Stresses above those listed under *Absolute Maximum Ratings* may cause permanent damage to the device. Exposure to absolute maximum conditions for extended periods may affect device reliability.

ELECTRICAL CHARACTERISTICS: $AV_{DD} = 5V$

All specifications at $T_A = T_{MIN}$ to T_{MAX} , $AV_{DD} = +4.75V$ to $+5.5V$, $IOV_{DD} = +1.8V$ to $+5.5V$, $V_{REFH} = 5V$, $V_{REFL} = 0V$, and gain = 1X mode, unless otherwise noted.

PARAMETER	CONDITIONS	DAC9881			UNIT	
		MIN	TYP	MAX		
ACCURACY⁽¹⁾						
Integral linearity error	Measured by line passing through codes 2048 and 260096	DAC9881S	±2	±3	LSB	
		DAC9881SB	±1	±2	LSB	
Differential linearity error	Measured by line passing through codes 2048 and 260096	DAC9881S	-1	±0.75	±2	LSB
		DAC9881SB		±0.5	±1	LSB
Monotonicity		18			Bits	
Zero-scale error	$T_A = +25^\circ C$, code = 2048			±16	LSB	
	T_{MIN} to T_{MAX} , code = 2048			±32	LSB	
Zero-scale drift ⁽²⁾	Code = 2048		±0.25	±0.8	ppm/°C of FSR	
Gain error	$T_A = +25^\circ C$, measured by line passing through codes 2048 and 260096		±16	±32	LSB	
Gain temperature drift ⁽²⁾	Measured by line passing through codes 2048 and 260096		±0.25	±0.4	ppm/°C	
PSRR ⁽²⁾	$V_{OUT} = \text{full-scale}$, $AV_{DD} = +5V \pm 10\%$			32	LSB/V	
ANALOG OUTPUT⁽²⁾						
Voltage output ⁽³⁾		0		AV_{DD}	V	
Output voltage drift vs time	Device operating for 500 hours at $+25^\circ C$		0.1		ppm of FSR	
	Device operating for 1000 hours at $+25^\circ C$		0.2		ppm of FSR	
Output current ⁽⁴⁾			2.5		mA	
Maximum load capacitance			200		pF	
Short-circuit current			+31/-50		mA	
REFERENCE INPUT⁽²⁾						
V_{REFH} input voltage range	$AV_{DD} = +5.5V$	1.25	5.0	AV_{DD}	V	
V_{REFH} input capacitance			5		pF	
V_{REFH} input impedance			4.5		kΩ	
V_{REFL} input voltage range		-0.2	0	+0.2	V	
V_{REFL} input capacitance			4.5		pF	
V_{REFL} input impedance			5		kΩ	
DYNAMIC PERFORMANCE⁽²⁾						
Settling time	To $\pm 0.003\%$ FS, $R_L = 10k\Omega$, $C_L = 50pF$, code 04000h to 3C000h		5		μs	
Slew rate	From 10% to 90% of 0V to +5V		2.5		V/μs	
Code change glitch	Code = 1FFFFh to 20000h to 1FFFFh	$V_{REFH} = 5V$, gain = 1X mode		37	nV-s	
		$V_{REFH} = 2.5V$, gain = 1X mode		18	nV-s	
		$V_{REFH} = 1.25V$, gain = 1X mode		9	nV-s	
		$V_{REFH} = 2.5V$, gain = 2X mode		21	nV-s	
		$V_{REFH} = 1.25V$, gain = 2X mode		10	nV-s	
Digital feedthrough	$\overline{CS} = \text{high}$, $f_{SCLK} = 1kHz$		1		nV-s	
Output noise voltage density	$f = 1kHz$ to $100kHz$, full-scale output	Gain = 1	24	30	nV/√Hz	
		Gain = 2	40	48	nV/√Hz	
Output noise voltage	$f = 0.1Hz$ to $10Hz$, full-scale output		2		μV _{PP}	

(1) DAC output range is 0V to +5V. 1LSB = 19μV.

(2) Ensured by design. Not production tested.

(3) The output from the V_{OUT} pin is $[(V_{REFH} - V_{REFL})/262144] \times \text{CODE} \times \text{Buffer GAIN} + V_{REFL}$. The maximum range of V_{OUT} is 0V to AV_{DD} . The full-scale of the output must be less than AV_{DD} ; otherwise, output saturation occurs.

(4) Refer to [Figure 26](#), [Figure 27](#), and [Figure 28](#) for details.

ELECTRICAL CHARACTERISTICS: AV_{DD} = 5V (continued)

All specifications at T_A = T_{MIN} to T_{MAX}, AV_{DD} = +4.75V to +5.5V, IOV_{DD} = +1.8V to +5.5V, V_{REFH} = 5V, V_{REFL} = 0V, and gain = 1X mode, unless otherwise noted.

PARAMETER	CONDITIONS	DAC9881			UNIT
		MIN	TYP	MAX	
DIGITAL INPUTS⁽⁵⁾					
High-level input voltage, V _{IH}	IOV _{DD} = 4.5V to 5.5V	3.8		IOV _{DD} + 0.3	V
	IOV _{DD} = 2.7V to 3.3V	2.1		IOV _{DD} + 0.3	V
	IOV _{DD} = 1.7V to 2.0V	1.5		IOV _{DD} + 0.3	V
Low-level input voltage, V _{IL}	IOV _{DD} = 4.5V to 5.5V	–0.3		0.8	V
	IOV _{DD} = 2.7V to 3.3V	–0.3		0.6	V
	IOV _{DD} = 1.7V to 2.0V	–0.3		0.3	V
Digital input current (I _{IN})			±1	±10	μA
Digital input capacitance			5		pF
DIGITAL OUTPUT⁽⁵⁾					
High-level output voltage, V _{OH}	IOV _{DD} = 2.7V to 5.5V, I _{OH} = –1mA	IOV _{DD} – 0.2			V
	IOV _{DD} = 1.7V to 2.0V, I _{OH} = –500μA	IOV _{DD} – 0.2			V
Low-level output voltage, V _{OL}	IOV _{DD} = 2.7V to 5.5V, I _{OL} = 1mA			0.2	V
	IOV _{DD} = 1.7 to 2.0V, I _{OL} = 500μA			0.2	V
POWER SUPPLY					
AV _{DD}		+4.75	+5.0	+5.5	V
IOV _{DD}		+1.7		AV _{DD}	V
AI _{DD}	V _{IH} = IOV _{DD} , V _{IL} = DGND		0.85	1.5	mA
IOI _{DD}	V _{IH} = IOV _{DD} , V _{IL} = DGND		1	10	μA
AI _{DD} power-down	PDN pin = IOV _{DD}		25	50	μA
Power dissipation	AV _{DD} = 5.0V		4.3	7.5	mW
TEMPERATURE RANGE					
Specified performance		–40		+105	°C

(5) Ensured by design. Not production tested.

ELECTRICAL CHARACTERISTICS: $AV_{DD} = 2.7V$

All specifications at $T_A = T_{MIN}$ to T_{MAX} , $AV_{DD} = +2.7V$ to $+3.3V$, $IOV_{DD} = +1.8V$ to AV_{DD} , $V_{REFH} = 2.5V$, $V_{REFL} = 0V$ and gain = 1X mode, unless otherwise noted.

PARAMETER	CONDITIONS	DAC9881			UNIT
		MIN	TYP	MAX	
ACCURACY⁽¹⁾					
Integral linearity error	Measured by line passing through codes 2048 and 262143	DAC9881S	±2.5	±3.5	LSB
		DAC9881SB	±2	±3	LSB
Differential linearity error	Measured by line passing through codes 2048 and 262143	DAC9881S	±1	±2	LSB
		DAC9881SB	±0.75	±1.5	LSB
Zero-scale error	$T_A = +25^\circ C$, code = 2048			±32	LSB
	T_{MIN} to T_{MAX} , code = 2048			±64	LSB
Zero-scale drift ⁽²⁾	Code = 2048		±0.5	±1.6	ppm/ $^\circ C$ of FSR
Gain error	$T_A = +25^\circ C$, measured by line passing through codes 2048 and 262143		±32	±64	LSB
Gain temperature drift ⁽²⁾	Measured by line passing through codes 2048 and 262143		±0.5	±0.8	ppm/ $^\circ C$
PSRR ⁽²⁾	$V_{OUT} = \text{full-scale}$, $AV_{DD} = +3V \pm 10\%$			64	LSB/V
ANALOG OUTPUT⁽²⁾					
Voltage output ⁽³⁾		0		AV_{DD}	V
Output voltage drift vs time	Device operating for 500 hours at $+25^\circ C$		0.2		ppm of FSR
	Device operating for 1000 hours at $+25^\circ C$		0.4		ppm of FSR
Output current ⁽⁴⁾			2.5		mA
Maximum load capacitance			200		pF
Short-circuit current			+31/–50		mA
REFERENCE INPUT⁽²⁾					
V_{REFH} input voltage range	$AV_{DD} = +3V$	1.25	2.5	AV_{DD}	V
V_{REFH} input capacitance			5		pF
V_{REFH} input impedance			4.5		k Ω
V_{REFL} input voltage range		–0.2	0	+0.2	V
V_{REFL} input capacitance			4.5		pF
V_{REFL} input impedance			5		k Ω
DYNAMIC PERFORMANCE⁽²⁾					
Settling time	To $\pm 0.003\%$ FS, $R_L = 10k\Omega$, $C_L = 50pF$, code 04000h to 3C000h		5		μs
Slew rate	From 10% to 90% of 0V to +2.5V		2.5		V/ μs
Code change glitch	Code = 1FFFFh to 20000h to 1FFFFh	$V_{REFH} = 2.5V$, gain = 1X mode	18		nV-s
		$V_{REFH} = 1.25V$, gain = 1X mode	9		nV-s
		$V_{REFH} = 1.25V$, gain = 2X mode	10		nV-s
Digital feedthrough	$\overline{CS} = \text{high}$, $f_{SCLK} = 1kHz$		1		nV-s
Output noise voltage density	$f = 1kHz$ to $100kHz$, full-scale output	Gain = 1	24	30	nV/ \sqrt{Hz}
		Gain = 2	40	48	nV/ \sqrt{Hz}
Output noise voltage	$f = 0.1Hz$ to $10Hz$, full-scale output		2		μV_{PP}

(1) DAC output range is 0V to +2.5V. 1LSB = 9.5 μV .

(2) Ensured by design. Not production tested.

(3) The output from the V_{OUT} pin = $[(V_{REFH} - V_{REFL})/262144] \times \text{CODE} \times \text{Buffer GAIN} + V_{REFL}$. The maximum range of V_{OUT} is 0V to AV_{DD} . The full-scale of the output must be less than AV_{DD} ; otherwise, output saturation occurs.

(4) Refer to [Figure 55](#), [Figure 56](#), and [Figure 57](#) for details.

ELECTRICAL CHARACTERISTICS: AV_{DD} = 2.7V (continued)

All specifications at T_A = T_{MIN} to T_{MAX}, AV_{DD} = +2.7V to +3.3V, IOV_{DD} = +1.8V to AV_{DD}, V_{REFH} = 2.5V, V_{REFL} = 0V and gain = 1X mode, unless otherwise noted.

PARAMETER	CONDITIONS	DAC9881			UNIT
		MIN	TYP	MAX	
DIGITAL INPUTS⁽⁵⁾					
High-level input voltage, V _{IH}	IOV _{DD} = 2.7V to 3.3V	2.1		IOV _{DD} + 0.3	V
	IOV _{DD} = 1.7V to 2.0V	1.5		IOV _{DD} + 0.3	V
Low-level input voltage, V _{IL}	IOV _{DD} = 2.7V to 3.3V	-0.3		0.6	V
	IOV _{DD} = 1.7V to 2.0V	-0.3		0.3	V
Digital input current (I _{IN})			±1	±10	μA
Digital input capacitance			5		pF
DIGITAL OUTPUT⁽⁵⁾					
High-level output voltage, V _{OH}	IOV _{DD} = 2.7V to 3.3V, I _{OH} = -1mA	IOV _{DD} - 0.2			V
	IOV _{DD} = 1.7V to 2.0V, I _{OH} = -500μA	IOV _{DD} - 0.2			V
Low-level output voltage, V _{OL}	IOV _{DD} = 2.7V to 3.3V, I _{OL} = 1mA	0.2			V
	IOV _{DD} = 1.7 to 2.0V, I _{OL} = 500μA	0.2			V
POWER SUPPLY					
AV _{DD}		+2.7	+3.0	+3.3	V
IOV _{DD}		+1.7		AV _{DD}	V
AI _{DD}	V _{IH} = IOV _{DD} , V _{IL} = DGND		0.75	1.2	mA
IOI _{DD}	V _{IH} = IOV _{DD} , V _{IL} = DGND		1	10	μA
AI _{DD} power-down	PDN pin = IOV _{DD}		25	50	μA
Power dissipation	AV _{DD} = 3.0V		2.3	3.6	mW
TEMPERATURE RANGE					
Specified performance		-40		+105	°C

(5) Ensured by design. Not production tested.

PIN CONFIGURATION

RGE PACKAGE⁽¹⁾ QFN-24 (TOP VIEW)

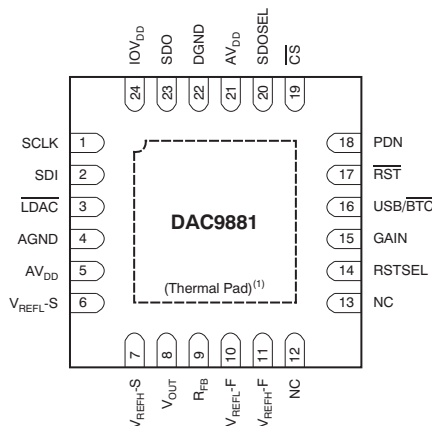

- (1) The thermal pad is internally connected to the substrate. This pad can be connected to the analog ground or left floating. Keep the thermal pad separate from the digital ground, if possible.

TERMINAL FUNCTIONS

TERMINAL NO.	NAME	I/O	DESCRIPTION
1	SCLK	I	SPI bus serial clock input
2	SDI	I	SPI bus serial data input
3	LDAC	I	Load DAC latch control input (active low). When LDAC is low, the DAC latch is transparent, and the contents of the input register are transferred to the DAC latch. The DAC output changes to the corresponding level simultaneously when the DAC latch is updated. It is recommended to connect this pin to IOV _{DD} through a pull-up resistor.
4	AGND	I	Analog ground
5	AV _{DD}	I	Analog power supply
6	V _{REFL-S}	I	Reference low input sense
7	V _{REFH-S}	I	Reference high input sense
8	V _{OUT}	O	Output of output buffer
9	R _{FB}	I	Feedback resistor connected to the inverting input of the output buffer.
10	V _{REFL-F}	I	Reference low input force
11	V _{REFH-F}	I	Reference high input force
12	NC	—	Do not connect.
13	NC	—	Do not connect.
14	RSTSEL	I	Selects the value of the output from the V _{OUT} pin after power-on or hardware reset. If RSTSEL = IOV _{DD} , then register data = 20000h. If RSTSEL = DGND, then register data = 00000h.
15	GAIN	I	Buffer gain setting. Gain = 1 when the pin is connected to DGND; Gain = 2 when the pin is connected to IOV _{DD} .
16	USB/BTC	I	Input data format selection. Input data are straight binary format when the pin is connected to IOV _{DD} , and in twos complement format when the pin is connected to DGND.
17	RST	I	Reset input (active low). Logic low on this pin causes the device to perform a reset.
18	PDN	I	Power-down input (active high). Logic high on this pin forces the device into power-down status. In power-down, the V _{OUT} pin connects to AGND through a 10kΩ resistor.
19	CS	I	SPI bus chip select input (active low). Data bits are not clocked into the serial shift register unless CS is low. When CS is high, SDO is in a high-impedance state. It is recommended to connect this pin to IOV _{DD} through a pull-up resistor.
20	SDOSEL	I	SPI serial data output selection. When SDOSEL is tied to IOV _{DD} , the contents of the existing input register are shifted out from the SDO pin; this is Stand-Alone mode. When SDOSEL is tied to DGND, the contents in the SPI input shift register are shifted out from the SDO pin; this is Daisy-Chain mode for daisy-chained communication.
21	AV _{DD}	I	Analog power supply. Must be connected to pin 5.
22	DGND	I	Digital ground
23	SDO	O	SPI bus serial data output. Refer to the Timing Diagrams for further detail.
24	IOV _{DD}	I	Interface power. Connect to +1.8V for 1.8V logic, +3V for 3V logic, and to +5V for 5V logic.

TIMING DIAGRAMS

Case 1: Standalone operation without SDO, $\overline{\text{LDAC}}$ tied low.

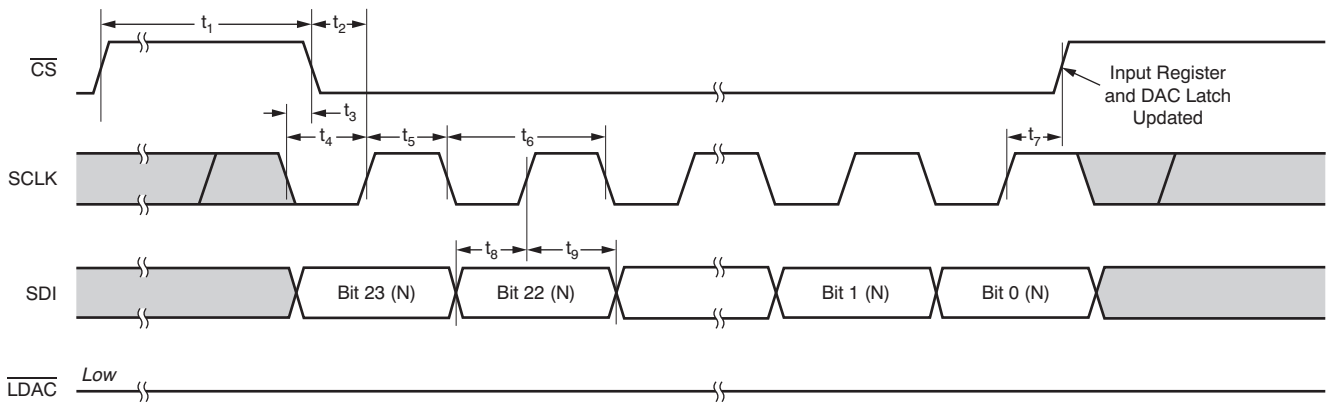

Case 2: Standalone operation without SDO, $\overline{\text{LDAC}}$ active.

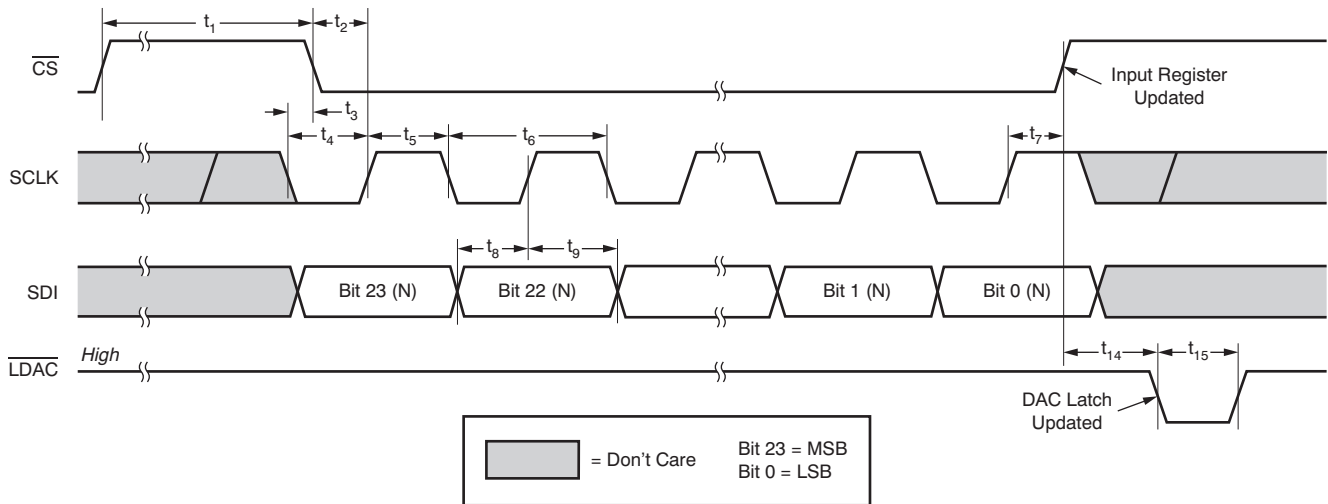

Figure 1. Timing Diagram for Standalone Operation without SDO

TIMING CHARACTERISTICS for Figure 1 ⁽¹⁾⁽²⁾⁽³⁾

At –40°C to +105°C, unless otherwise noted.

PARAMETER		CONDITIONS	MIN	MAX	UNIT
f _{SCLK}	Maximum clock frequency	2.7 ≤ AV _{DD} < 3.6V, 2.7 ≤ IOV _{DD} ≤ AV _{DD}		40	MHz
		3.6 ≤ AV _{DD} ≤ 5.5V, 2.7 ≤ IOV _{DD} ≤ AV _{DD}		50	MHz
t ₁	Minimum \overline{CS} high time	2.7 ≤ AV _{DD} < 3.6V, 2.7 ≤ IOV _{DD} ≤ AV _{DD}	50		ns
		3.6 ≤ AV _{DD} ≤ 5.5V, 2.7 ≤ IOV _{DD} ≤ AV _{DD}	30		ns
t ₂	Delay from \overline{CS} falling edge to SCLK rising edge	2.7 ≤ AV _{DD} < 3.6V, 2.7 ≤ IOV _{DD} ≤ AV _{DD}	10		ns
		3.6 ≤ AV _{DD} ≤ 5.5V, 2.7 ≤ IOV _{DD} ≤ AV _{DD}	8		ns
t ₃	Delay from SCLK falling edge to \overline{CS} falling edge	2.7 ≤ AV _{DD} < 3.6V, 2.7 ≤ IOV _{DD} ≤ AV _{DD}	0		ns
		3.6 ≤ AV _{DD} ≤ 5.5V, 2.7 ≤ IOV _{DD} ≤ AV _{DD}	0		ns
t ₄	SCLK low time	2.7 ≤ AV _{DD} < 3.6V, 2.7 ≤ IOV _{DD} ≤ AV _{DD}	10		ns
		3.6 ≤ AV _{DD} ≤ 5.5V, 2.7 ≤ IOV _{DD} ≤ AV _{DD}	10		ns
t ₅	SCLK high time	2.7 ≤ AV _{DD} < 3.6V, 2.7 ≤ IOV _{DD} ≤ AV _{DD}	15		ns
		3.6 ≤ AV _{DD} ≤ 5.5V, 2.7 ≤ IOV _{DD} ≤ AV _{DD}	10		ns
t ₆	SCLK cycle time	2.7 ≤ AV _{DD} < 3.6V, 2.7 ≤ IOV _{DD} ≤ AV _{DD}	25		ns
		3.6 ≤ AV _{DD} ≤ 5.5V, 2.7 ≤ IOV _{DD} ≤ AV _{DD}	20		ns
t ₇	Delay from SCLK rising edge to \overline{CS} rising edge	2.7 ≤ AV _{DD} < 3.6V, 2.7 ≤ IOV _{DD} ≤ AV _{DD}	10		ns
		3.6 ≤ AV _{DD} ≤ 5.5V, 2.7 ≤ IOV _{DD} ≤ AV _{DD}	10		ns
t ₈	Input data setup time	2.7 ≤ AV _{DD} < 3.6V, 2.7 ≤ IOV _{DD} ≤ AV _{DD}	8		ns
		3.6 ≤ AV _{DD} ≤ 5.5V, 2.7 ≤ IOV _{DD} ≤ AV _{DD}	5		ns
t ₉	Input data hold time	2.7 ≤ AV _{DD} < 3.6V, 2.7 ≤ IOV _{DD} ≤ AV _{DD}	5		ns
		3.6 ≤ AV _{DD} ≤ 5.5V, 2.7 ≤ IOV _{DD} ≤ AV _{DD}	5		ns
t ₁₄	Delay from \overline{CS} rising edge to \overline{LDAC} falling edge	2.7 ≤ AV _{DD} < 3.6V, 2.7 ≤ IOV _{DD} ≤ AV _{DD}	10		ns
		3.6 ≤ AV _{DD} ≤ 5.5V, 2.7 ≤ IOV _{DD} ≤ AV _{DD}	5		ns
t ₁₅	\overline{LDAC} pulse width	2.7 ≤ AV _{DD} < 3.6V, 2.7 ≤ IOV _{DD} ≤ AV _{DD}	15		ns
		3.6 ≤ AV _{DD} ≤ 5.5V, 2.7 ≤ IOV _{DD} ≤ AV _{DD}	10		ns

- (1) All input signals are specified with t_R = t_F = 2ns (10% to 90% of IOV_{DD}) and timed from a voltage level of IOV_{DD}/2.
- (2) Ensured by design. Not production tested.
- (3) Sample tested during the initial release and after any redesign or process changes that may affect these parameters.

Case 1: Standalone operation with output from SDO, $\overline{\text{LDAC}}$ tied low.

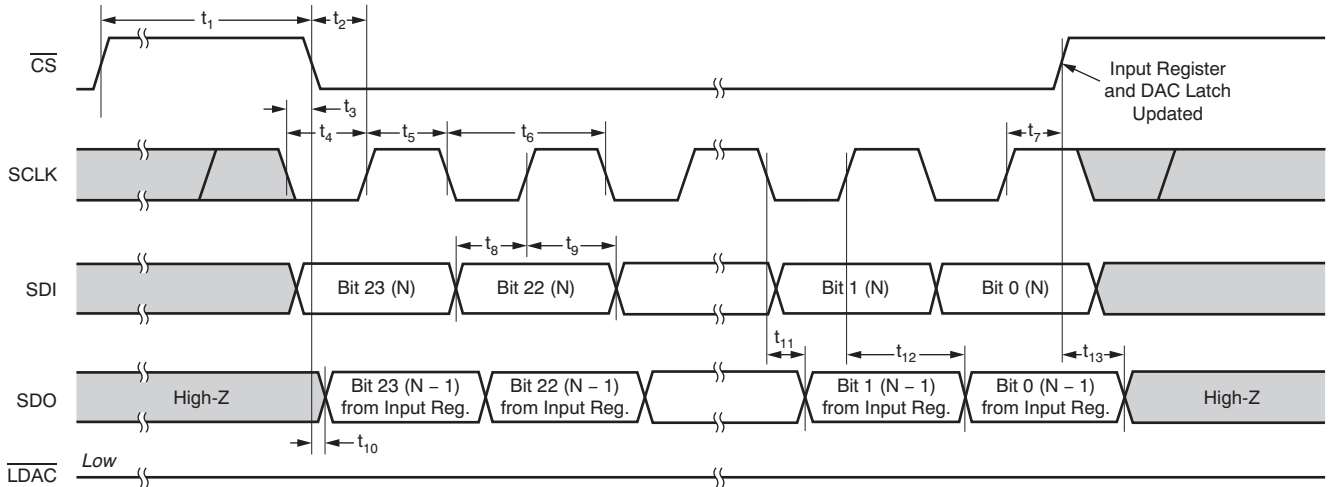

Case 2: Standalone operation with output from SDO, $\overline{\text{LDAC}}$ active.

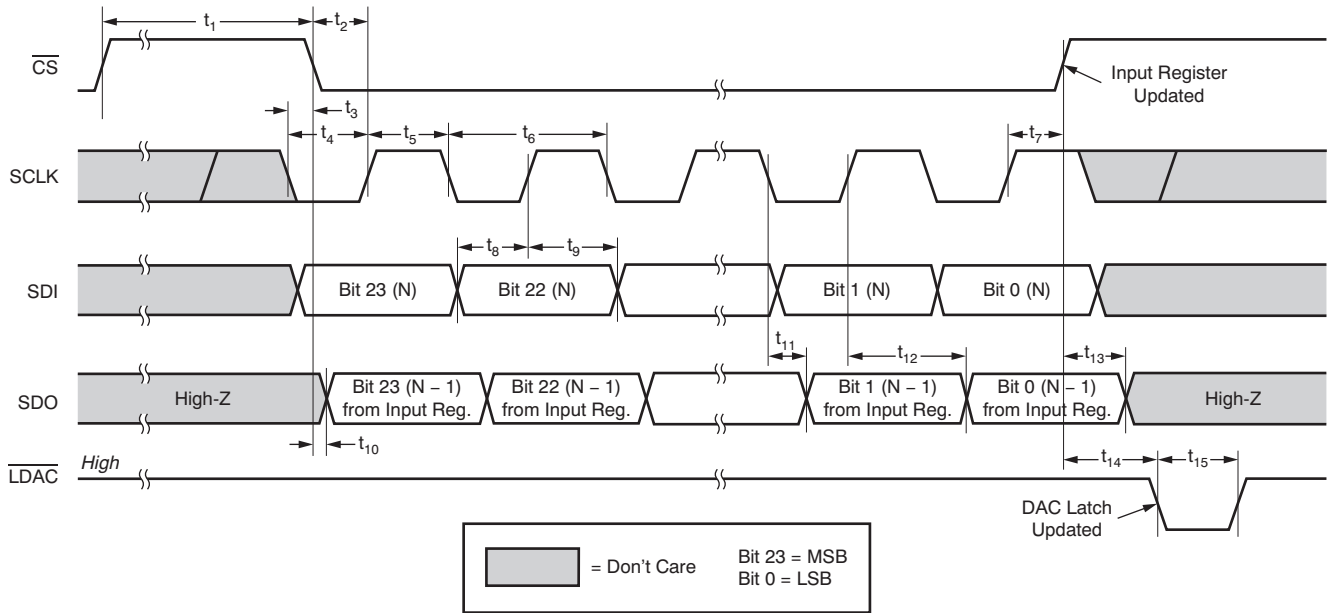
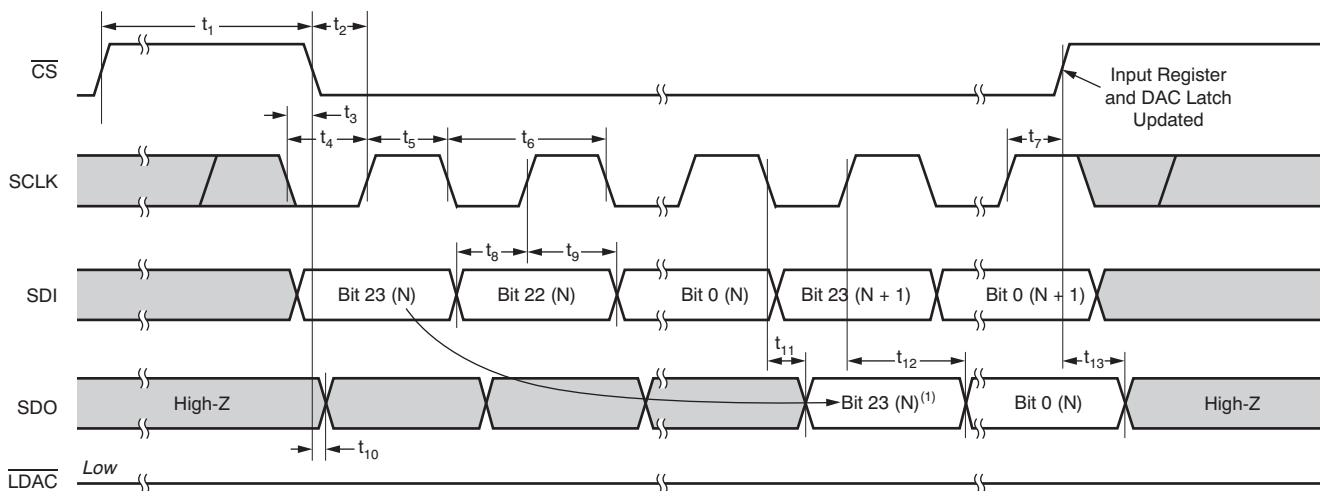
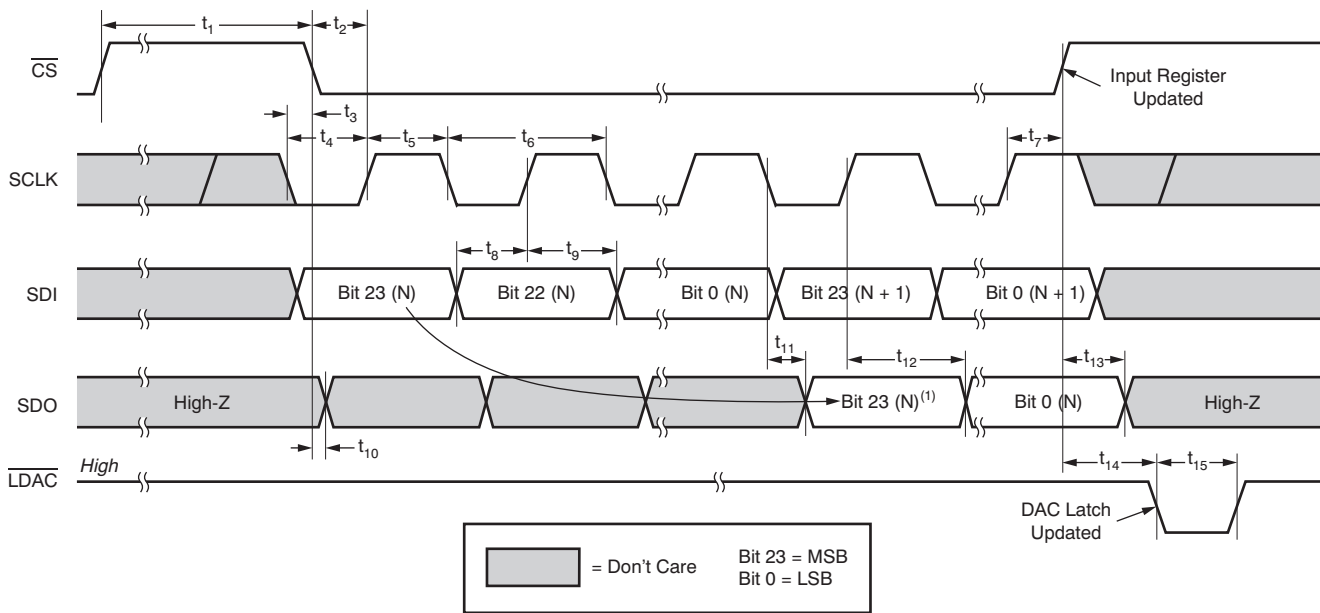

Figure 2. Timing Diagram for Standalone Operation with SDO

Case 1: Daisy Chain, $\overline{\text{LDAC}}$ tied low.



Case 2: Daisy Chain, $\overline{\text{LDAC}}$ active.



NOTE: (1) SDO data delayed from SDI by 24 clock cycles.

Figure 3. Timing Diagram for Daisy Chain Mode, Two Cascaded Devices

TIMING CHARACTERISTICS for Figure 2 and Figure 3⁽¹⁾⁽²⁾⁽³⁾

At –40°C to +105°C, unless otherwise noted.

PARAMETER		CONDITIONS	MIN	MAX	UNIT
f _{SCLK}	Maximum clock frequency	2.7 ≤ AV _{DD} < 3.6V, 2.7 ≤ IOV _{DD} ≤ AV _{DD}		20	MHz
		3.6 ≤ AV _{DD} ≤ 5.5V, 2.7 ≤ IOV _{DD} ≤ AV _{DD}		25	MHz
t ₁	Minimum \overline{CS} high time	2.7 ≤ AV _{DD} < 3.6V, 2.7 ≤ IOV _{DD} ≤ AV _{DD}	50		ns
		3.6 ≤ AV _{DD} ≤ 5.5V, 2.7 ≤ IOV _{DD} ≤ AV _{DD}	30		ns
t ₂	Delay from \overline{CS} falling edge to SCLK rising edge	2.7 ≤ AV _{DD} < 3.6V, 2.7 ≤ IOV _{DD} ≤ AV _{DD}	10		ns
		3.6 ≤ AV _{DD} ≤ 5.5V, 2.7 ≤ IOV _{DD} ≤ AV _{DD}	8		ns
t ₃	Delay from SCLK falling edge to \overline{CS} falling edge	2.7 ≤ AV _{DD} < 3.6V, 2.7 ≤ IOV _{DD} ≤ AV _{DD}	0		ns
		3.6 ≤ AV _{DD} ≤ 5.5V, 2.7 ≤ IOV _{DD} ≤ AV _{DD}	0		ns
t ₄	SCLK low time	2.7 ≤ AV _{DD} < 3.6V, 2.7 ≤ IOV _{DD} ≤ AV _{DD}	25		ns
		3.6 ≤ AV _{DD} ≤ 5.5V, 2.7 ≤ IOV _{DD} ≤ AV _{DD}	20		ns
t ₅	SCLK high time	2.7 ≤ AV _{DD} < 3.6V, 2.7 ≤ IOV _{DD} ≤ AV _{DD}	25		ns
		3.6 ≤ AV _{DD} ≤ 5.5V, 2.7 ≤ IOV _{DD} ≤ AV _{DD}	20		ns
t ₆	SCLK cycle time	2.7 ≤ AV _{DD} < 3.6V, 2.7 ≤ IOV _{DD} ≤ AV _{DD}	50		ns
		3.6 ≤ AV _{DD} ≤ 5.5V, 2.7 ≤ IOV _{DD} ≤ AV _{DD}	40		ns
t ₇	Delay from SCLK rising edge to \overline{CS} rising edge	2.7 ≤ AV _{DD} < 3.6V, 2.7 ≤ IOV _{DD} ≤ AV _{DD}	10		ns
		3.6 ≤ AV _{DD} ≤ 5.5V, 2.7 ≤ IOV _{DD} ≤ AV _{DD}	10		ns
t ₈	Input data setup time	2.7 ≤ AV _{DD} < 3.6V, 2.7 ≤ IOV _{DD} ≤ AV _{DD}	5		ns
		3.6 ≤ AV _{DD} ≤ 5.5V, 2.7 ≤ IOV _{DD} ≤ AV _{DD}	5		ns
t ₉	Input data hold time	2.7 ≤ AV _{DD} < 3.6V, 2.7 ≤ IOV _{DD} ≤ AV _{DD}	5		ns
		3.6 ≤ AV _{DD} ≤ 5.5V, 2.7 ≤ IOV _{DD} ≤ AV _{DD}	5		ns
t ₁₀	Delay from \overline{CS} falling edge to SDO valid	2.7 ≤ AV _{DD} < 3.6V, 2.7 ≤ IOV _{DD} ≤ AV _{DD}		15	ns
		3.6 ≤ AV _{DD} ≤ 5.5V, 2.7 ≤ IOV _{DD} ≤ AV _{DD}		10	ns
t ₁₁	Delay from SCLK falling edge to SDO valid	2.7 ≤ AV _{DD} < 3.6V, 2.7 ≤ IOV _{DD} ≤ AV _{DD}		20	ns
		3.6 ≤ AV _{DD} ≤ 5.5V, 2.7 ≤ IOV _{DD} ≤ AV _{DD}		15	ns
t ₁₂	SDO data hold from SCLK rising edge	2.7 ≤ AV _{DD} < 3.6V, 2.7 ≤ IOV _{DD} ≤ AV _{DD}	t ₅		ns
		3.6 ≤ AV _{DD} ≤ 5.5V, 2.7 ≤ IOV _{DD} ≤ AV _{DD}	t ₅		ns
t ₁₃	Delay from \overline{CS} rising edge to SDO high-Z	2.7 ≤ AV _{DD} < 3.6V, 2.7 ≤ IOV _{DD} ≤ AV _{DD}		8	ns
		3.6 ≤ AV _{DD} ≤ 5.5V, 2.7 ≤ IOV _{DD} ≤ AV _{DD}		5	ns
t ₁₄	Delay from \overline{CS} rising edge to \overline{LDAC} falling edge	2.7 ≤ AV _{DD} < 3.6V, 2.7 ≤ IOV _{DD} ≤ AV _{DD}	10		ns
		3.6 ≤ AV _{DD} ≤ 5.5V, 2.7 ≤ IOV _{DD} ≤ AV _{DD}	5		ns
t ₁₅	\overline{LDAC} pulse width	2.7 ≤ AV _{DD} < 3.6V, 2.7 ≤ IOV _{DD} ≤ AV _{DD}	15		ns
		3.6 ≤ AV _{DD} ≤ 5.5V, 2.7 ≤ IOV _{DD} ≤ AV _{DD}	10		ns

 (1) All input signals are specified with t_R = t_F = 2ns (10% to 90% of IOV_{DD}) and timed from a voltage level of IOV_{DD}/2.

(2) Ensured by design. Not production tested.

(3) Sample tested during the initial release and after any redesign or process changes that may affect these parameters.

TYPICAL CHARACTERISTICS: $V_{DD} = +5V$

At $T_A = +25^\circ C$, $V_{REFH} = +5.0V$, $V_{REFL} = 0V$, and Gain = 1X Mode, unless otherwise noted.

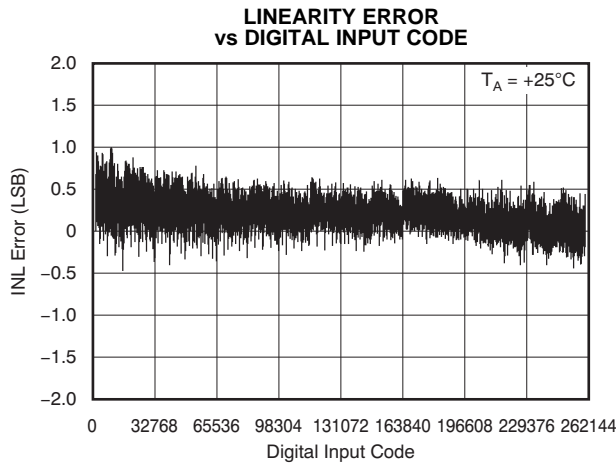

Figure 4.

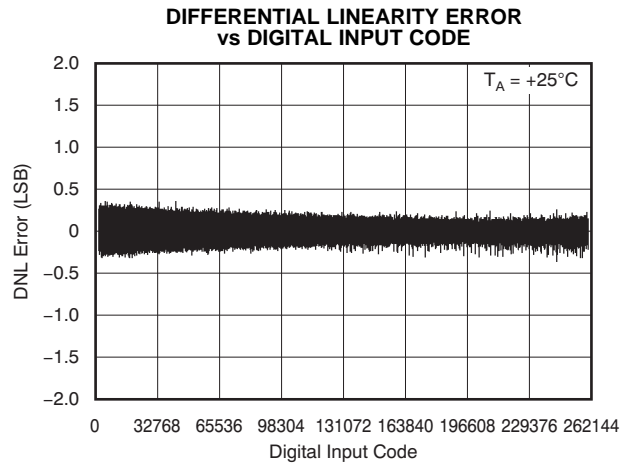

Figure 5.

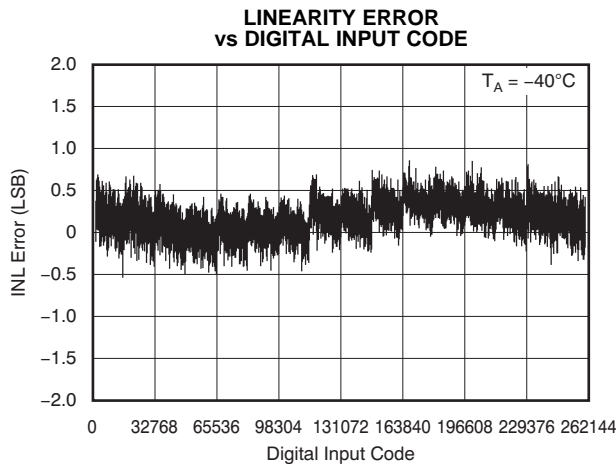

Figure 6.

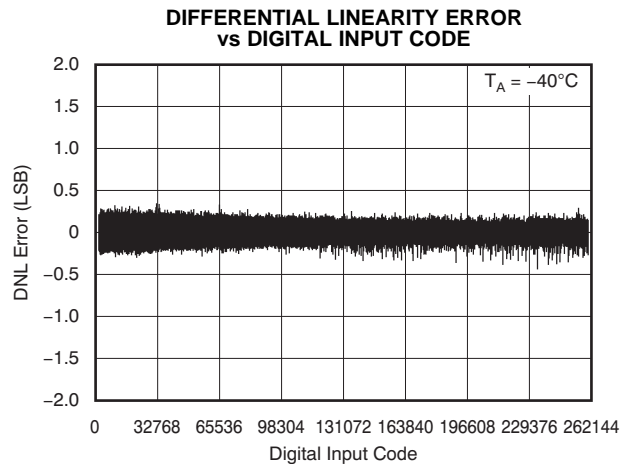

Figure 7.

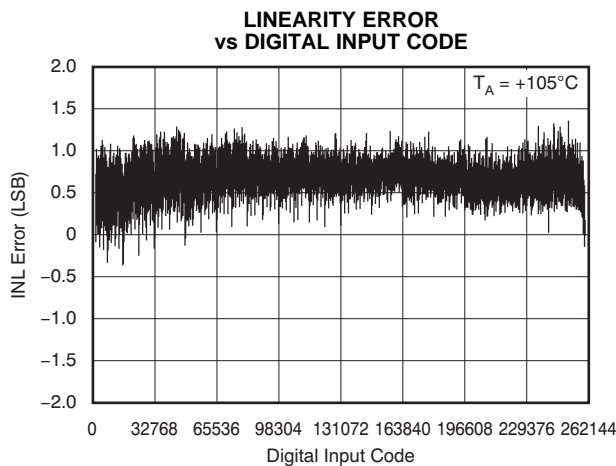

Figure 8.

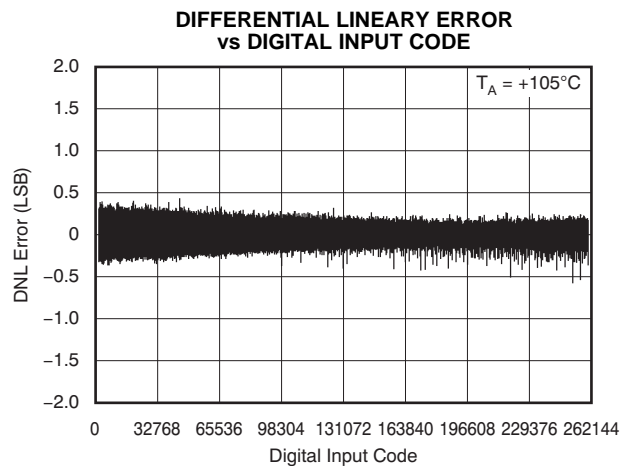

Figure 9.

TYPICAL CHARACTERISTICS: $A_{V_{DD}} = +5V$ (continued)

At $T_A = +25^\circ C$, $V_{REFH} = +5.0V$, $V_{REFL} = 0V$, and Gain = 1X Mode, unless otherwise noted.

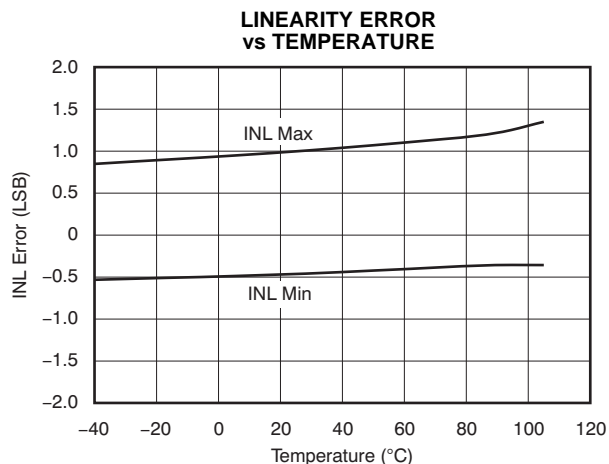

Figure 10.

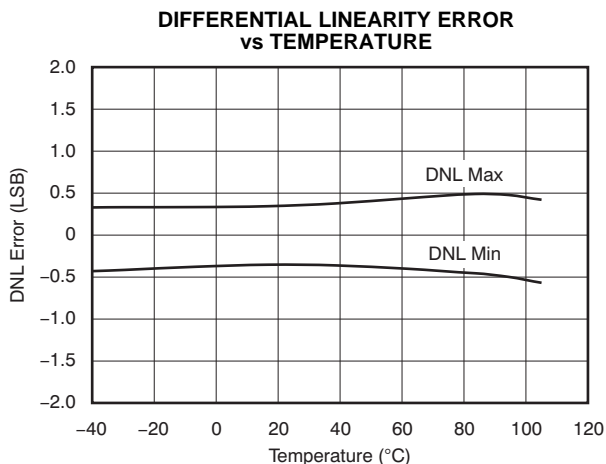

Figure 11.

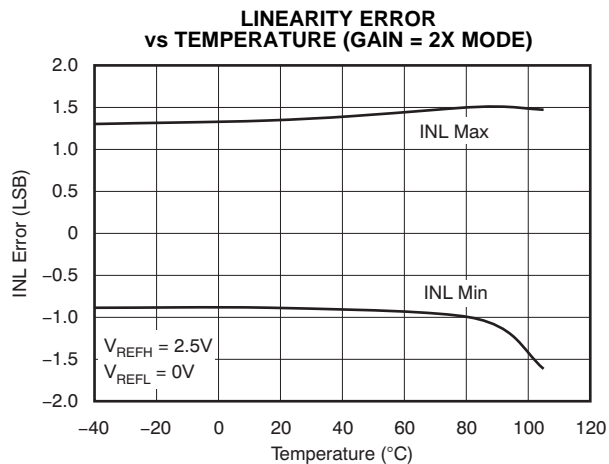

Figure 12.

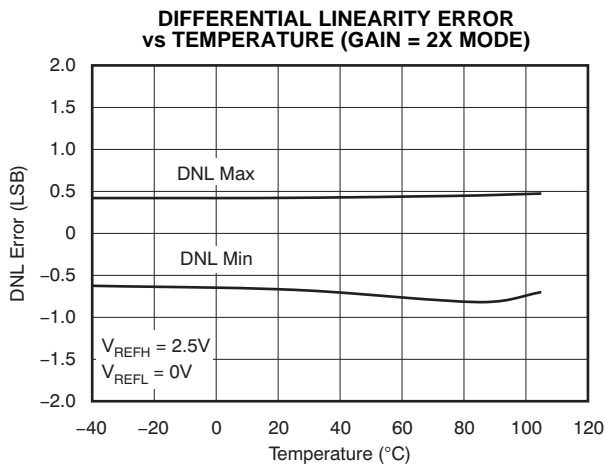

Figure 13.

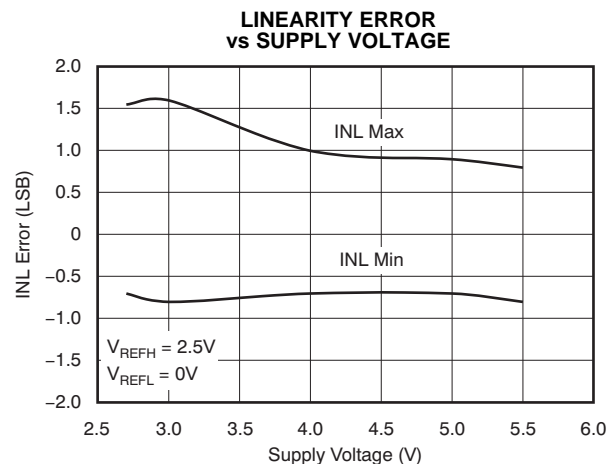

Figure 14.

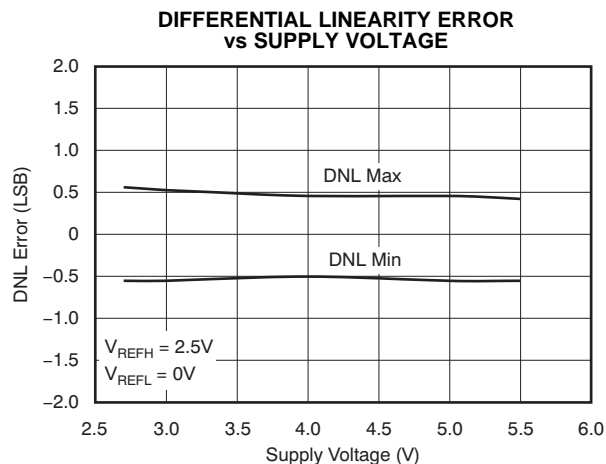

Figure 15.

TYPICAL CHARACTERISTICS: $A_{V_{DD}} = +5V$ (continued)

At $T_A = +25^\circ C$, $V_{REFH} = +5.0V$, $V_{REFL} = 0V$, and Gain = 1X Mode, unless otherwise noted.

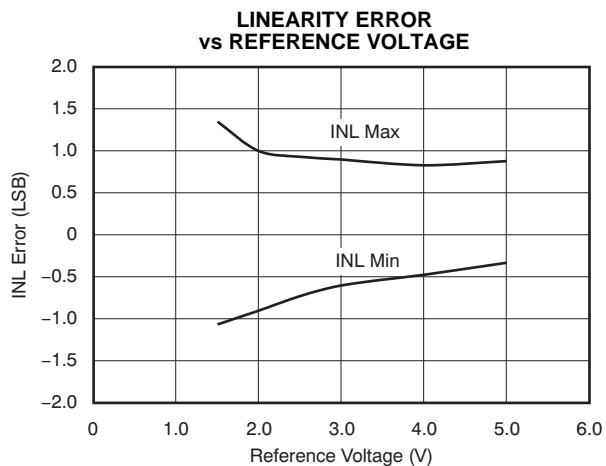

Figure 16.

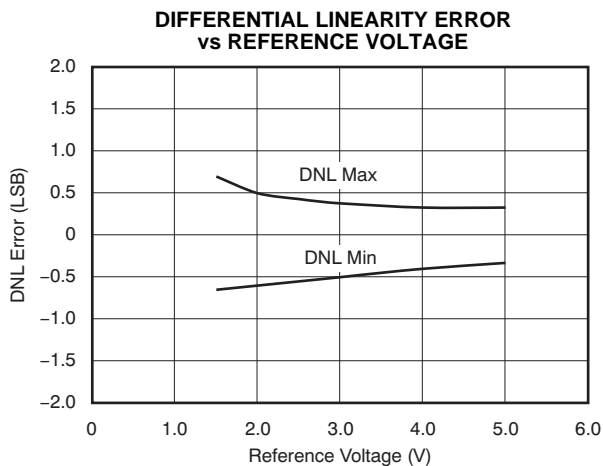

Figure 17.

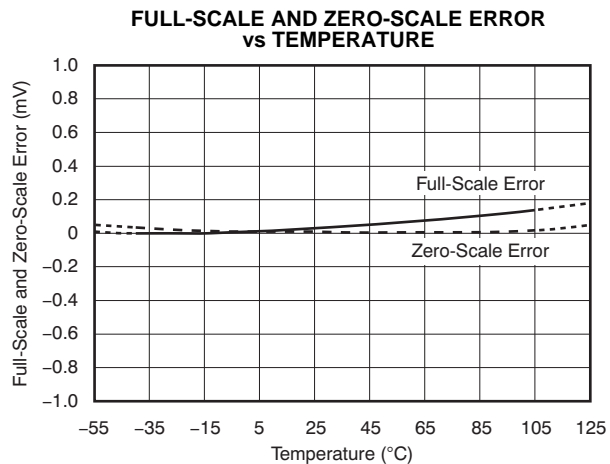

Figure 18.

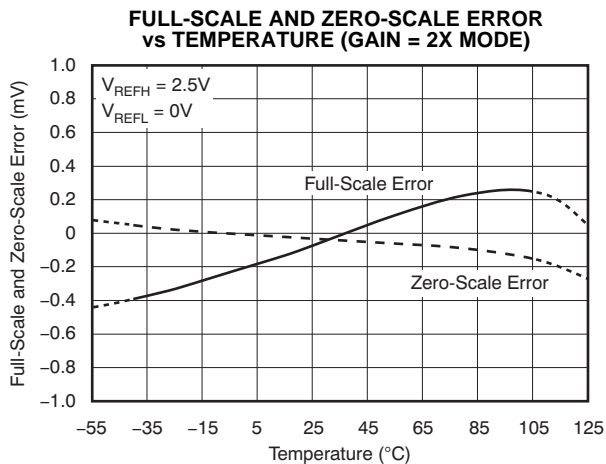

Figure 19.

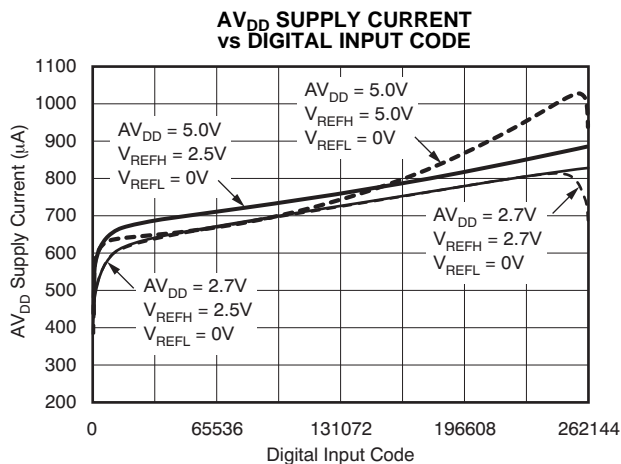

Figure 20.

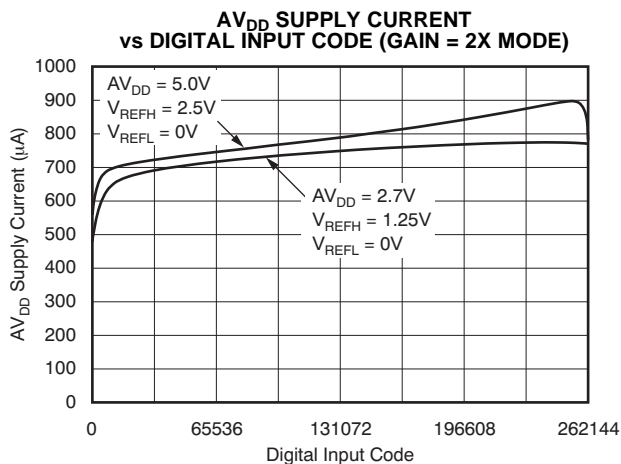

Figure 21.

TYPICAL CHARACTERISTICS: AV_{DD} = +5V (continued)

At T_A = +25°C, V_{REFH} = +5.0V, V_{REFL} = 0V, and Gain = 1X Mode, unless otherwise noted.

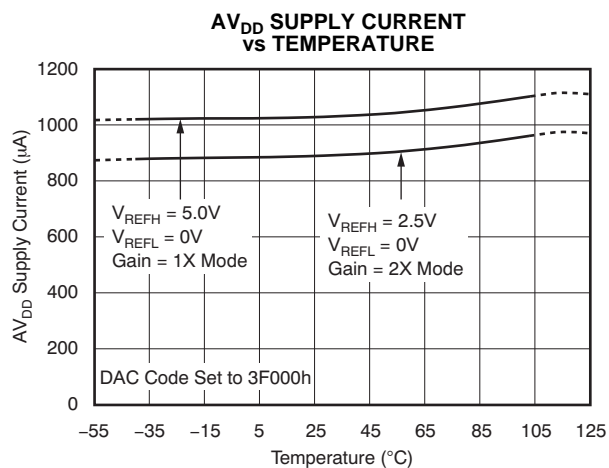

Figure 22.

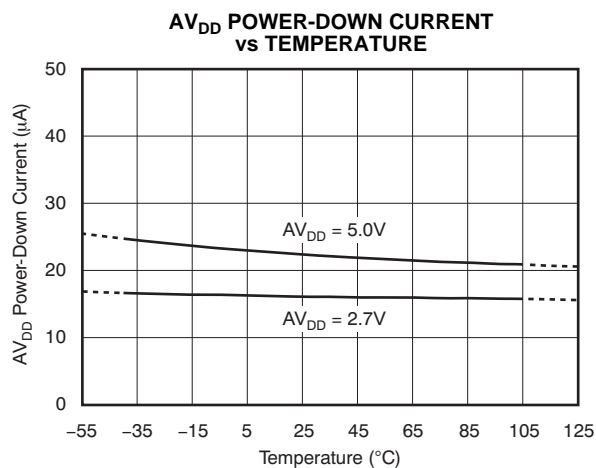

Figure 23.

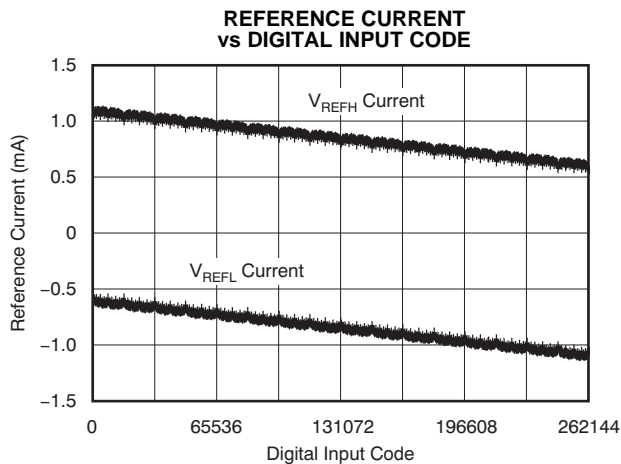

Figure 24.

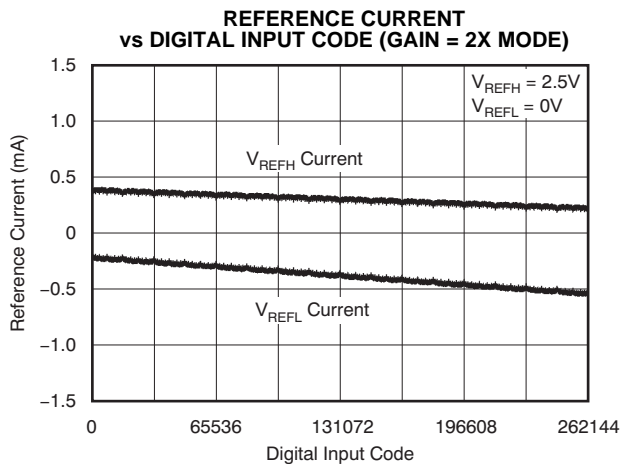

Figure 25.

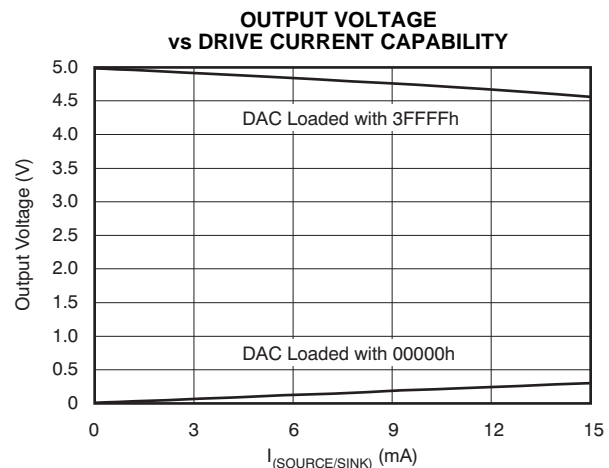

Figure 26.

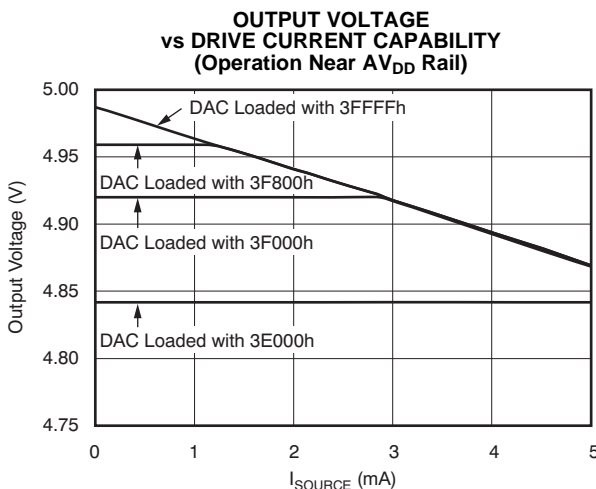

Figure 27.

TYPICAL CHARACTERISTICS: $AV_{DD} = +5V$ (continued)

At $T_A = +25^\circ C$, $V_{REFH} = +5.0V$, $V_{REFL} = 0V$, and Gain = 1X Mode, unless otherwise noted.

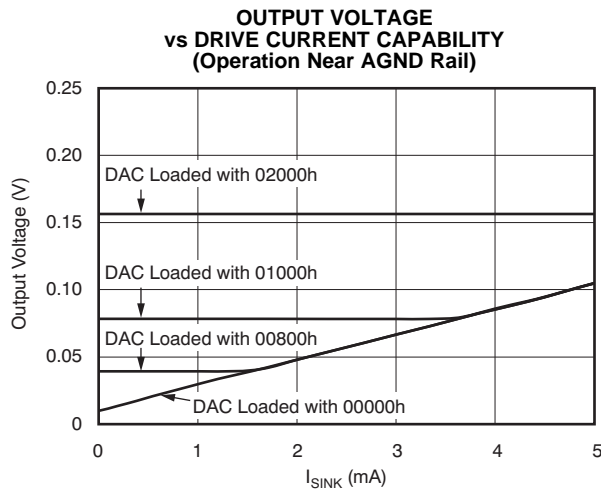

Figure 28.

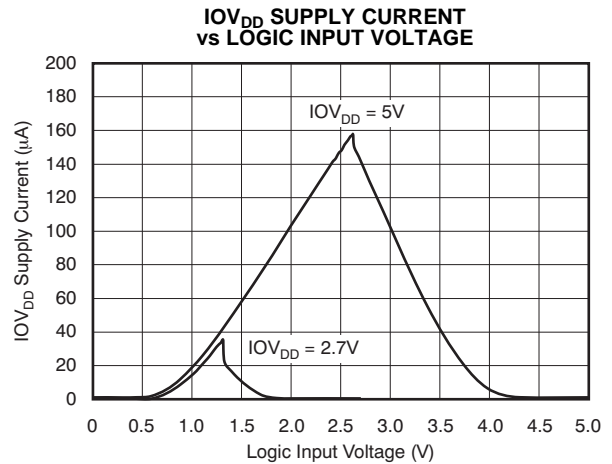

Figure 29.

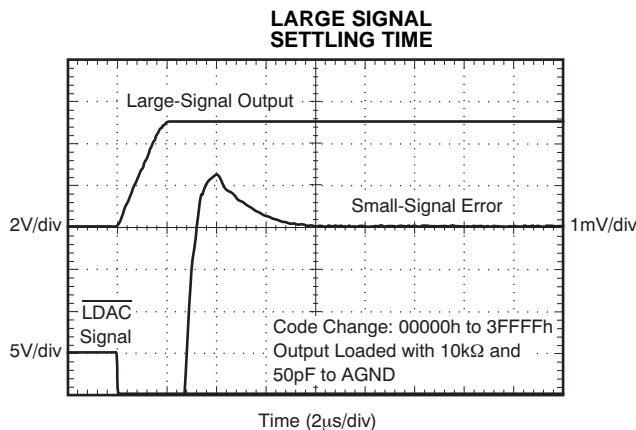

Figure 30.

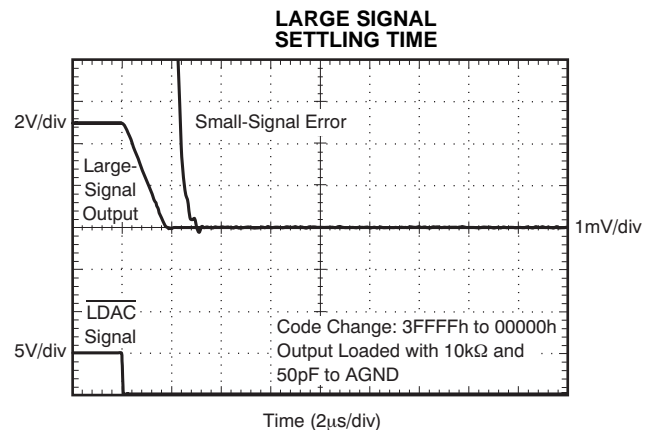

Figure 31.

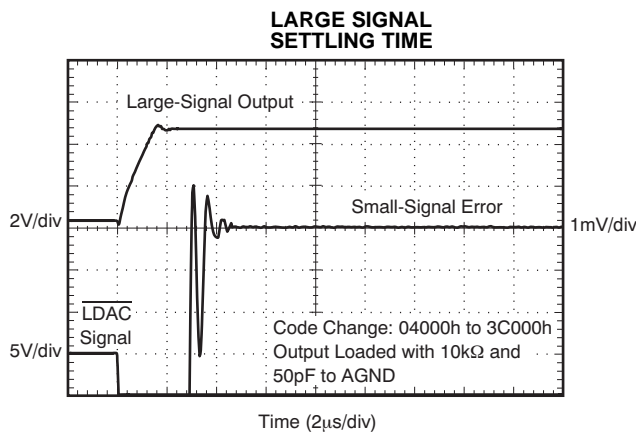

Figure 32.

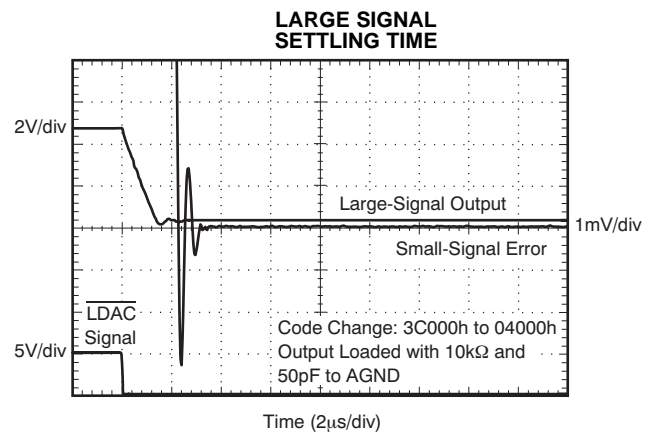

Figure 33.

TYPICAL CHARACTERISTICS: $V_{DD} = +5V$ (continued)

At $T_A = +25^\circ C$, $V_{REFH} = +5.0V$, $V_{REFL} = 0V$, and Gain = 1X Mode, unless otherwise noted.

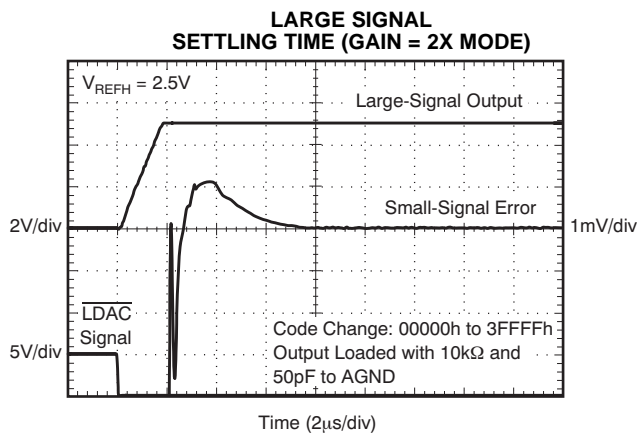

Figure 34.

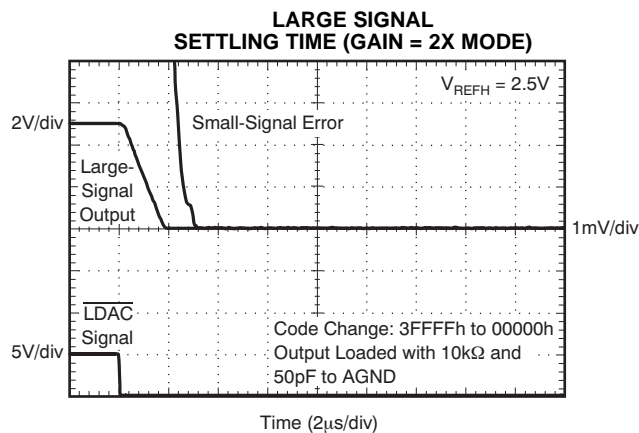

Figure 35.

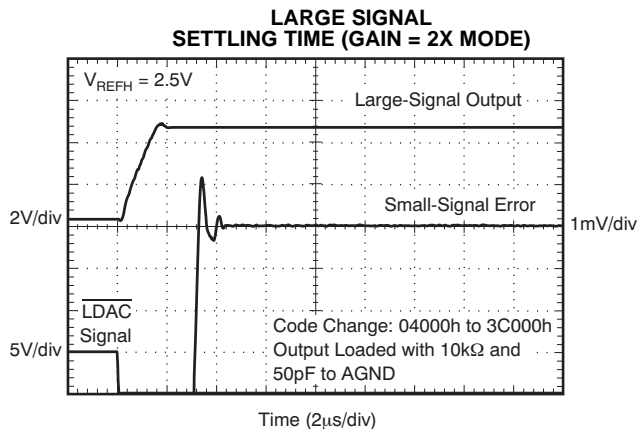

Figure 36.

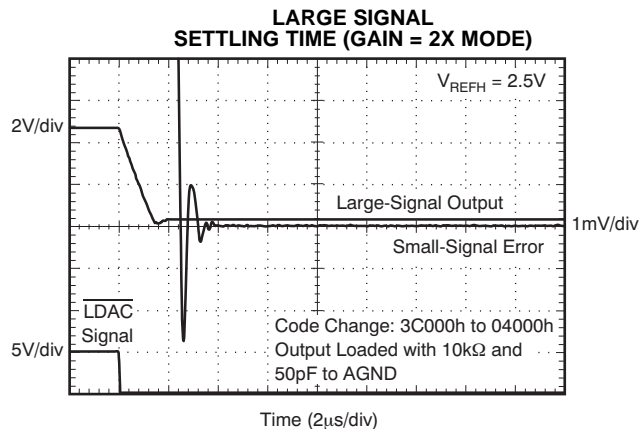

Figure 37.

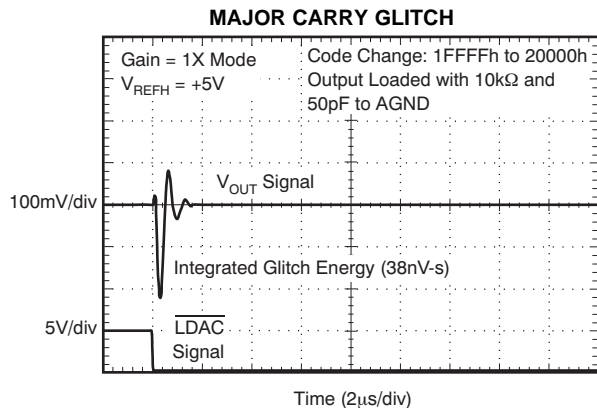

Figure 38.

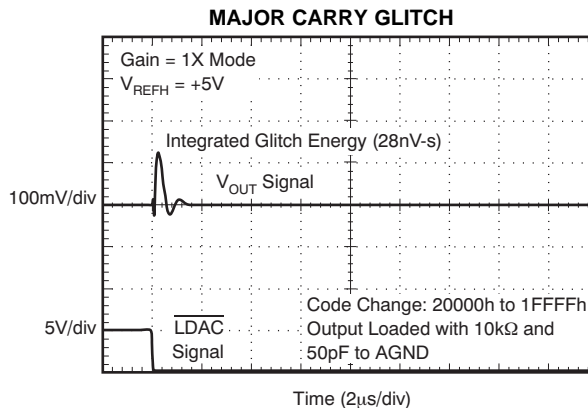

Figure 39.

TYPICAL CHARACTERISTICS: $V_{DD} = +5V$ (continued)

At $T_A = +25^\circ C$, $V_{REFH} = +5.0V$, $V_{REFL} = 0V$, and Gain = 1X Mode, unless otherwise noted.

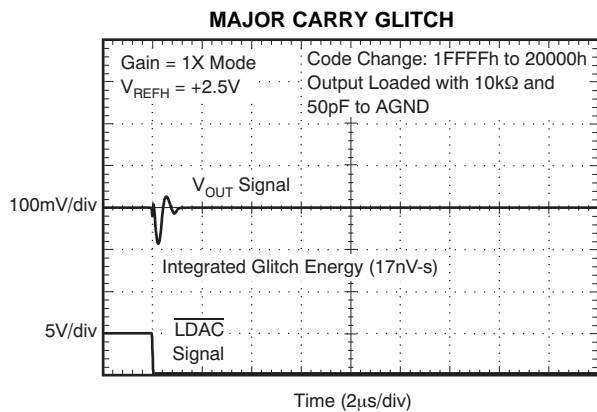

Figure 40.

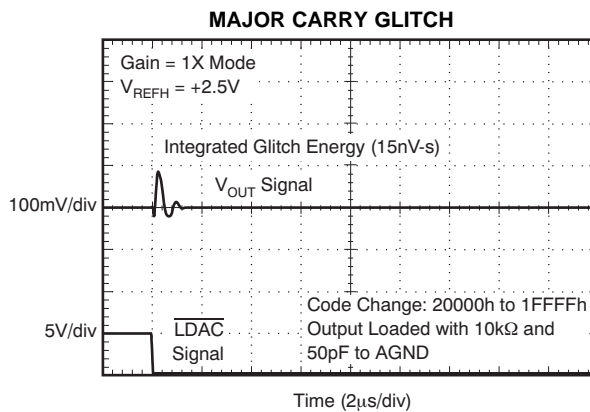

Figure 41.

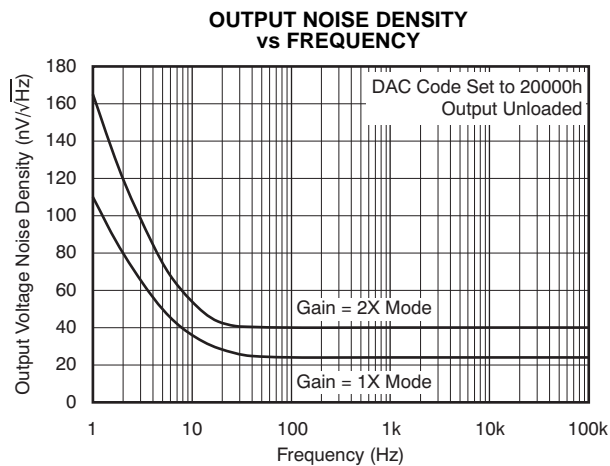

Figure 42.

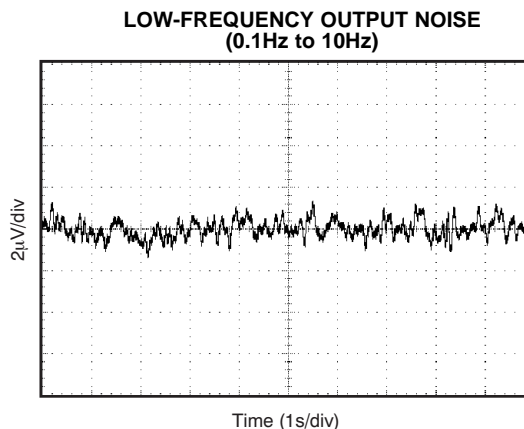

Figure 43.

TYPICAL CHARACTERISTICS: $V_{DD} = +2.7V$

At $T_A = +25^\circ C$, $V_{REFH} = +2.5V$, $V_{REFL} = 0V$, and Gain = 1X Mode, unless otherwise noted.

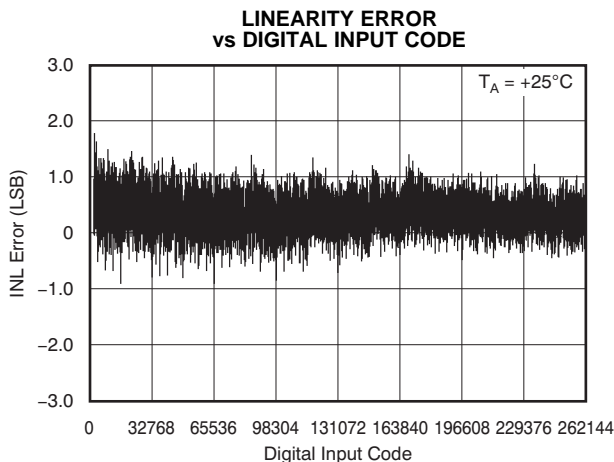

Figure 44.

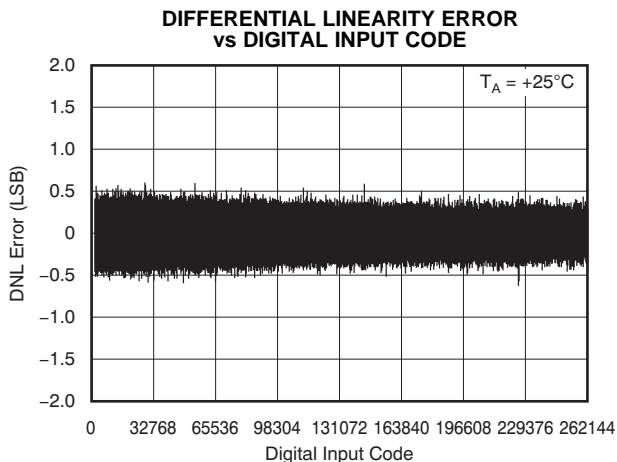

Figure 45.

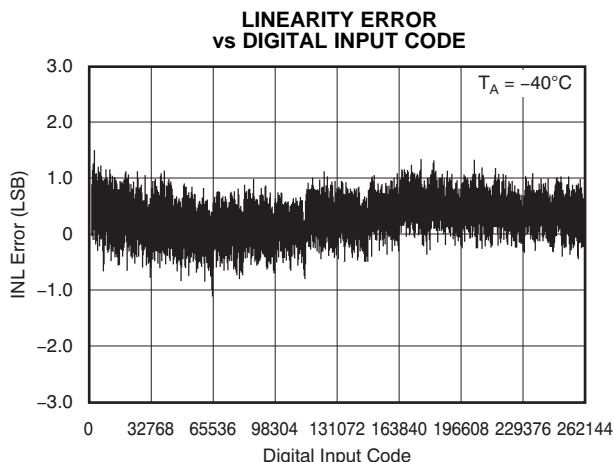

Figure 46.

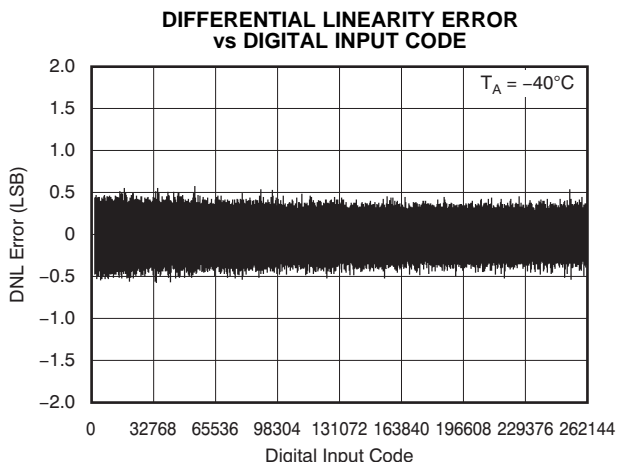

Figure 47.

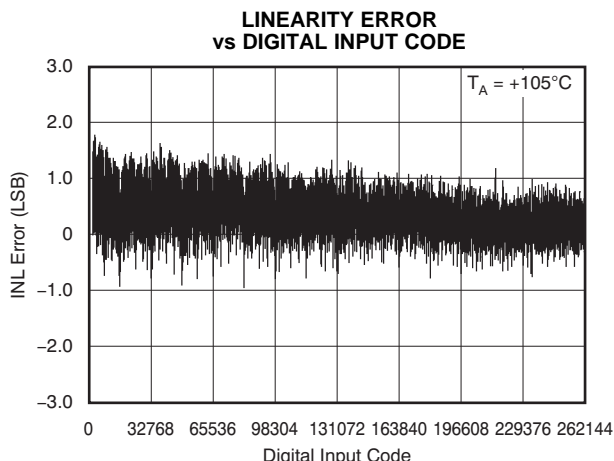

Figure 48.

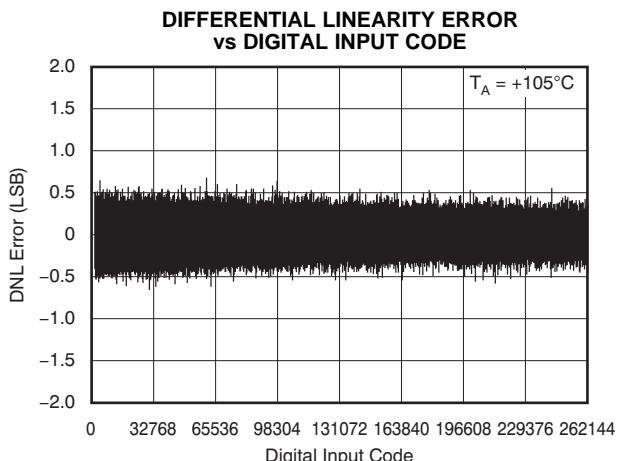

Figure 49.

TYPICAL CHARACTERISTICS: $V_{DD} = +2.7V$ (continued)

At $T_A = +25^\circ C$, $V_{REFH} = +2.5V$, $V_{REFL} = 0V$, and Gain = 1X Mode, unless otherwise noted.

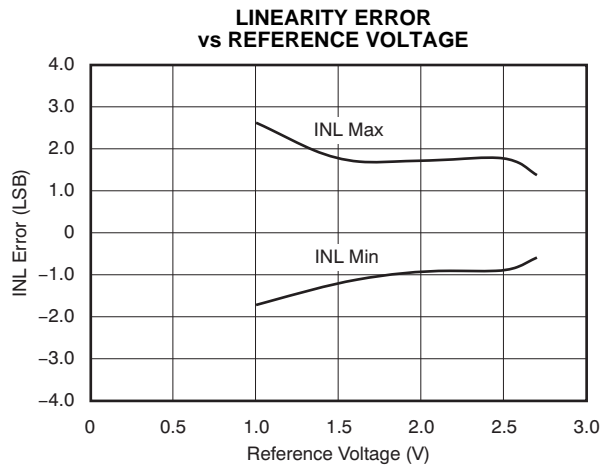

Figure 50.

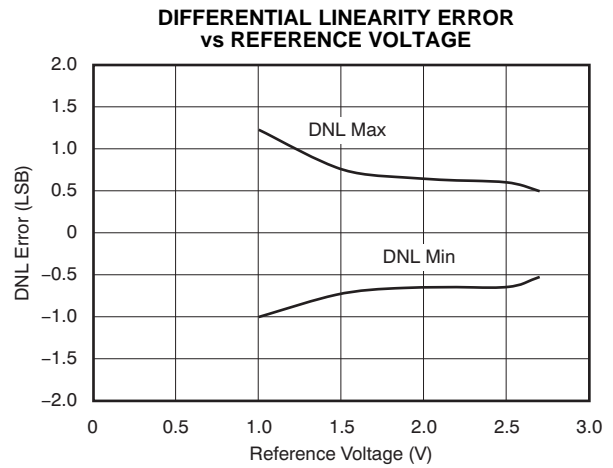

Figure 51.

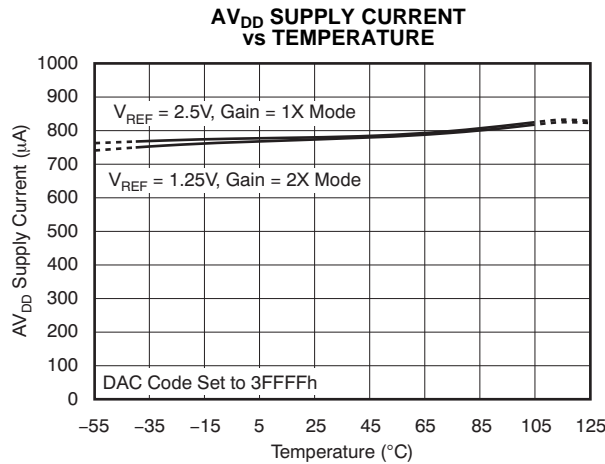

Figure 52.

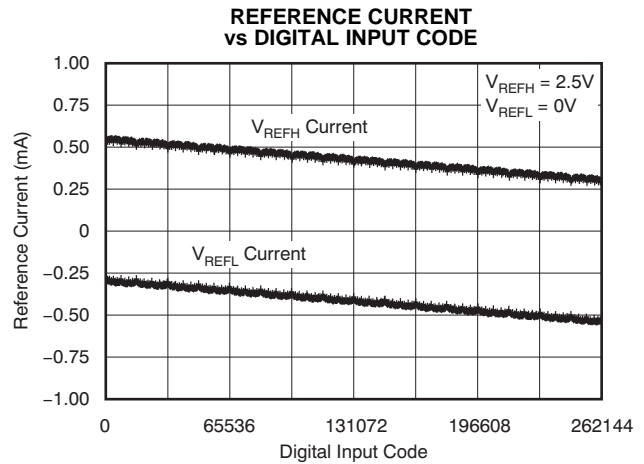

Figure 53.

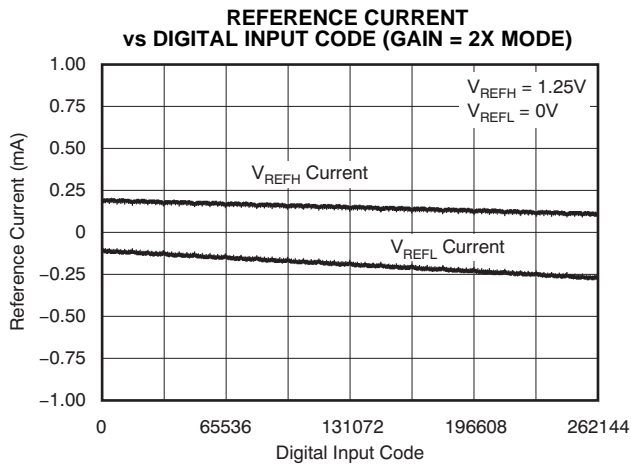

Figure 54.

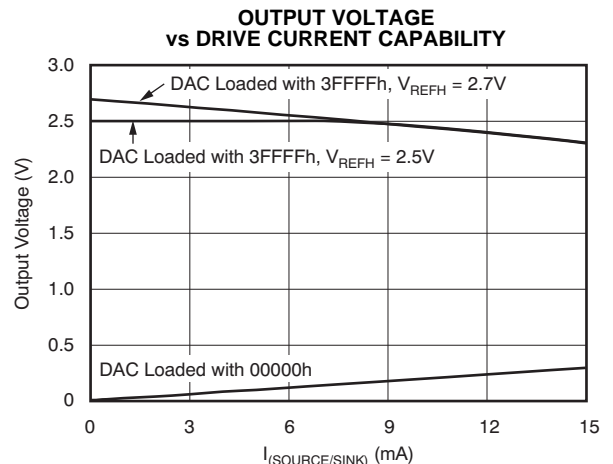

Figure 55.

TYPICAL CHARACTERISTICS: $V_{DD} = +2.7V$ (continued)

At $T_A = +25^\circ C$, $V_{REFH} = +2.5V$, $V_{REFL} = 0V$, and Gain = 1X Mode, unless otherwise noted.

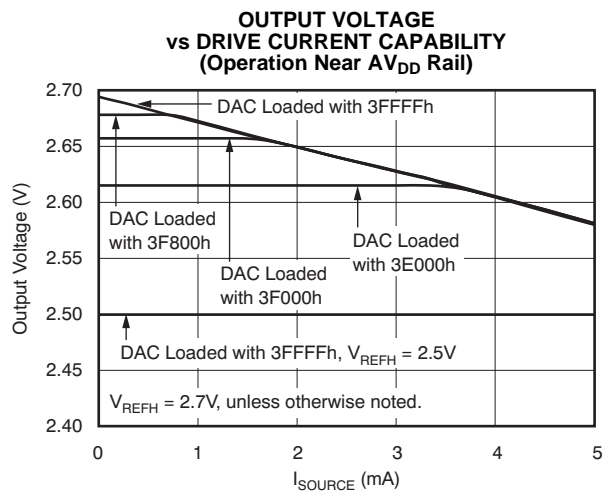

Figure 56.

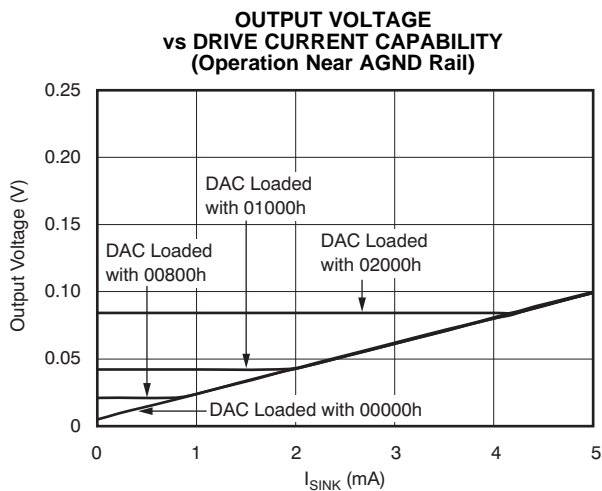

Figure 57.

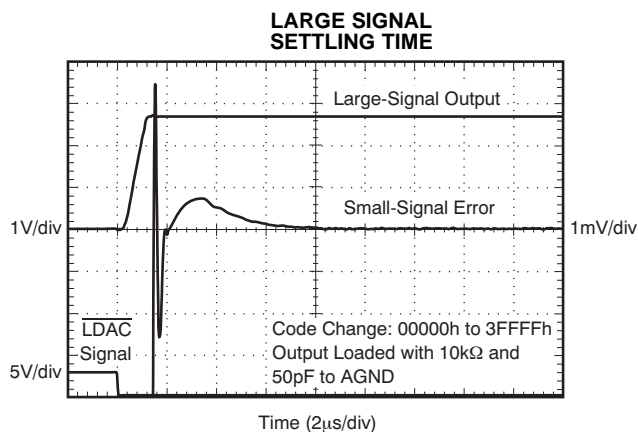

Figure 58.

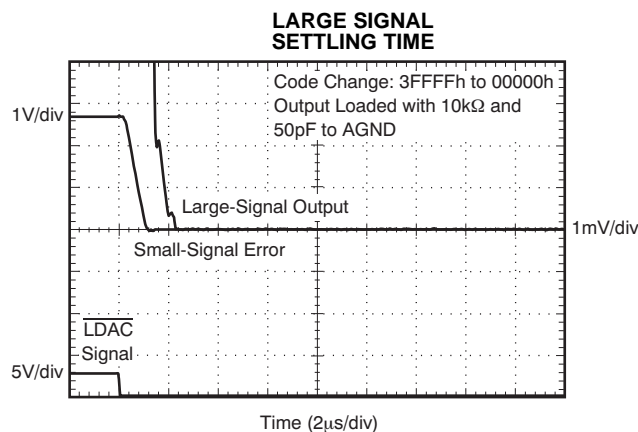

Figure 59.

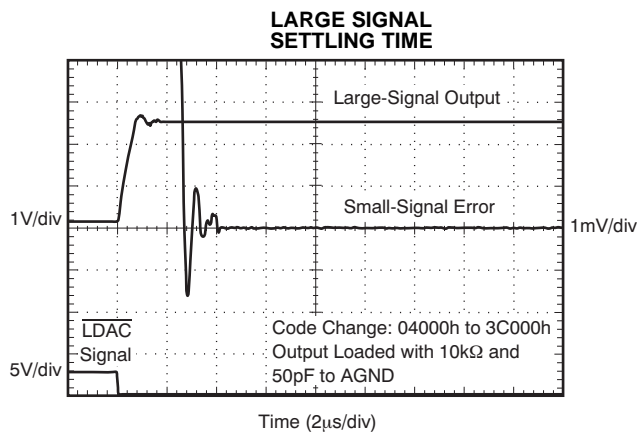

Figure 60.

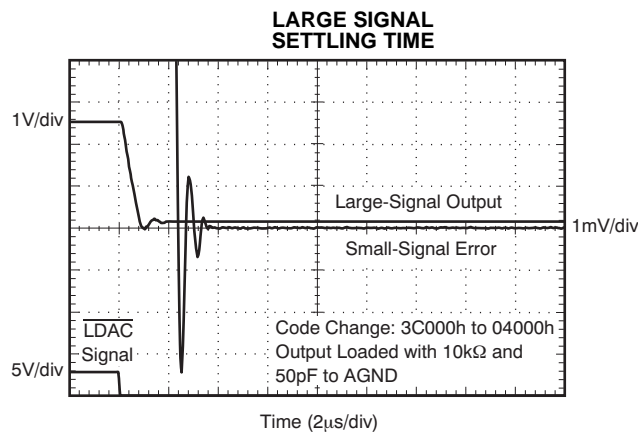

Figure 61.

TYPICAL CHARACTERISTICS: $AV_{DD} = +2.7V$ (continued)

At $T_A = +25^\circ C$, $V_{REFH} = +2.5V$, $V_{REFL} = 0V$, and Gain = 1X Mode, unless otherwise noted.

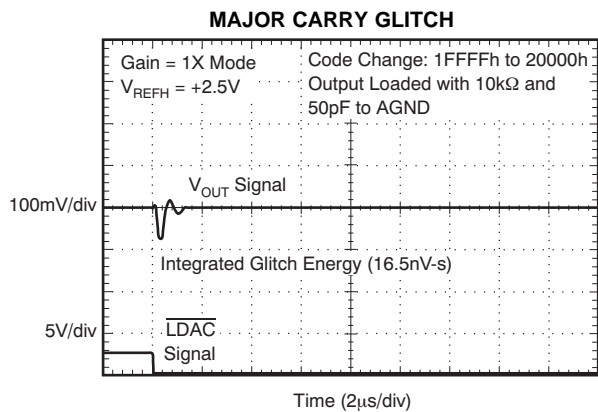

Figure 62.

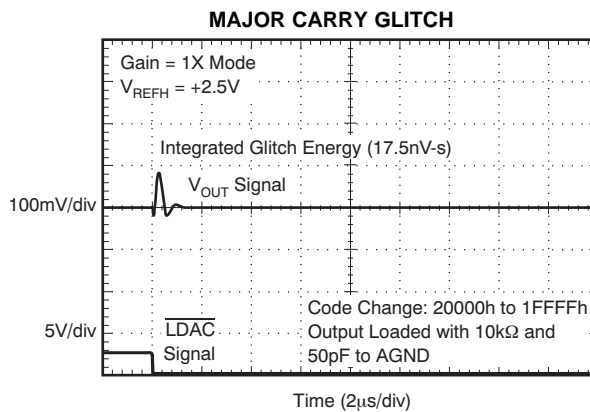

Figure 63.

THEORY OF OPERATION

GENERAL DESCRIPTION

The DAC9881 is a single-channel, 18-bit, serial-input, voltage-output digital-to-analog converter (DAC). The architecture is an R-2R ladder configuration with the four MSBs segmented, followed by an operational amplifier that serves as a buffer, as shown in Figure 64. The on-chip output buffer allows rail-to-rail output swings while providing a low output impedance to drive loads. The DAC9881 operates from a single analog output power supply that ranges from 2.7V to 5.5V, and typically consumes 850 μ A when operating with a 5V supply. Data are written to the device in a 24-bit word format, via an SPI serial interface. To enable compatibility with 1.8V, 3V, or 5V logic families, an IOV_{DD} supply pin is provided. This pin allows the DAC9881 input and output logic to be powered from the same logic supply used to interface signals to and from the device. Internal voltage translators are included in the DAC9881 to interface digital signals to the device core. See Figure 65 for the basic configuration of the DAC9881.

To ensure a known power-up state, the DAC9881 is designed with a power-on reset function. Upon power-up, the DAC9881 is reset to either zero-scale or midscale depending on the state of the RSTSEL pin. A hardware reset can be performed by using the $\overline{\text{RST}}$ and RSTSEL pins.

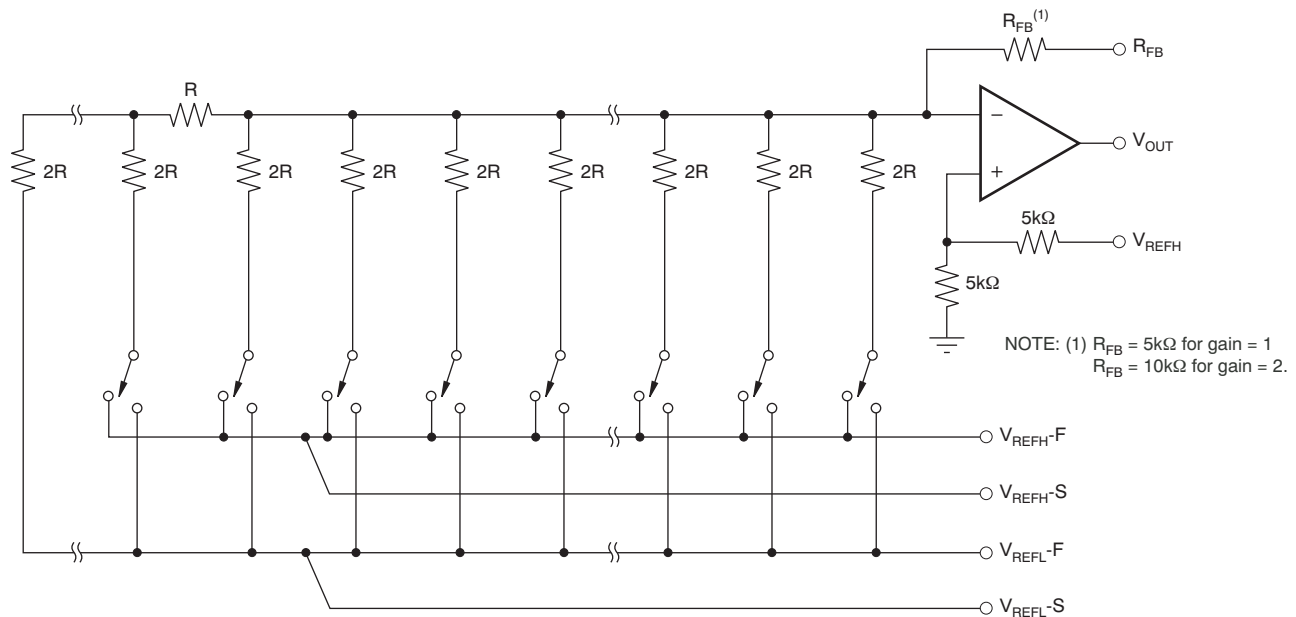

Figure 64. DAC9881 Architecture

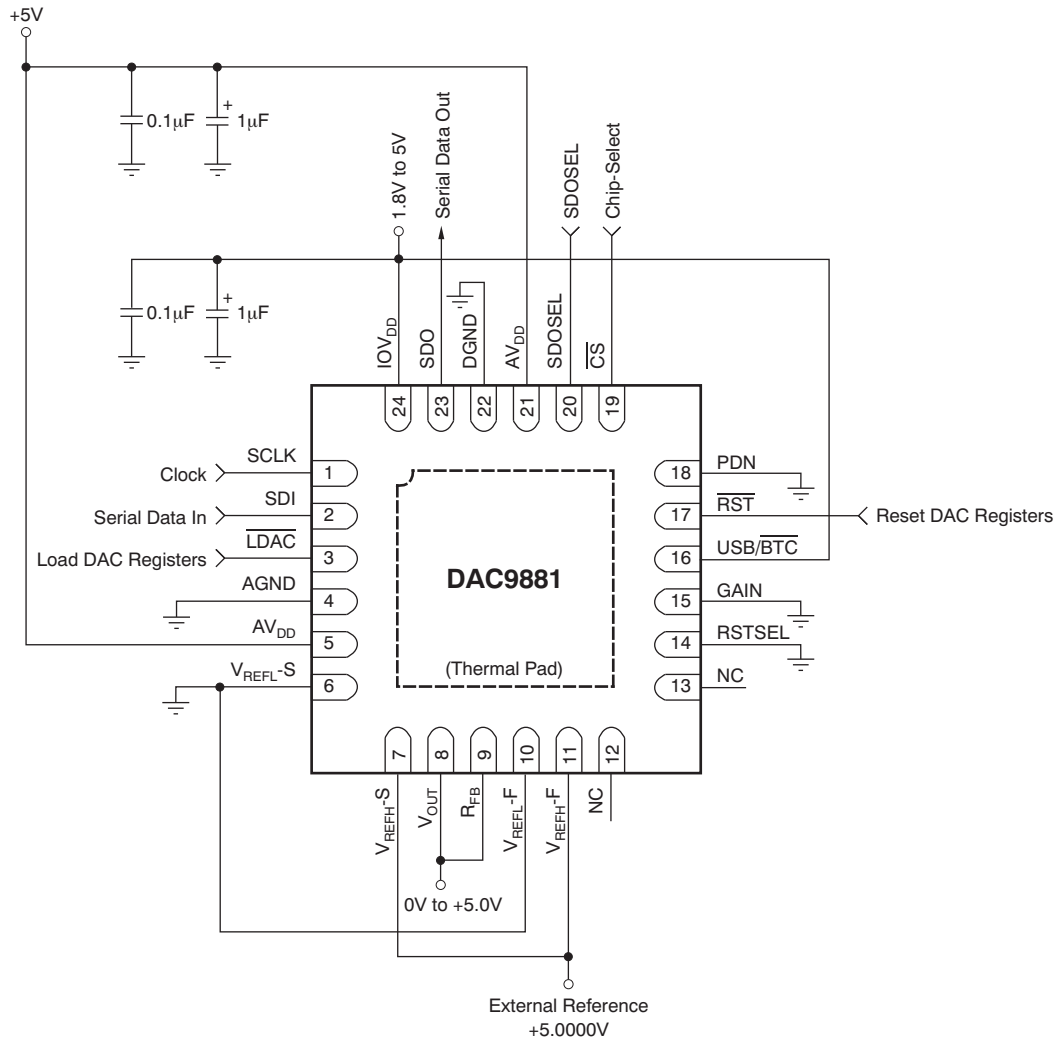

Figure 65. Basic Configuration

ANALOG OUTPUT

The DAC9881 offers a force and sense output configuration for the high open-loop gain output amplifier. This feature allows the loop around the output amplifier to be closed at the load (as shown in Figure 66), thus ensuring an accurate output voltage. The output buffer V_{OUT} and R_{FB} pins are provided so that the output op amp buffer feedback can be connected at the load. Without a driven load, the DAC9881 output typically swings to within 15mV of the AGND and AV_{DD} supply rails. Because of the high accuracy of these DACs, system design problems such as grounding and wiring resistance become very important. A 18-bit converter with a 5V full-scale range has an LSB value of $19\mu V$. The DAC9881 has a typical feedback resistor current of 0.5mA; thus, a series wiring resistance of only $100m\Omega$ (R_{W1}) causes a voltage drop of $50\mu V$. In terms of a system layout, the resistivity of a typical 1-ounce copper-clad printed circuit board (PCB) is $0.5m\Omega$ per square. For a 0.5mA current, a 0.25mm wide printed circuit conductor 25mm long results in a voltage drop of $25\mu V$. Note that the wiring resistance of R_{W2} is not critical as long as the feedback resistor (R_{FB}) is connected at the driven load.

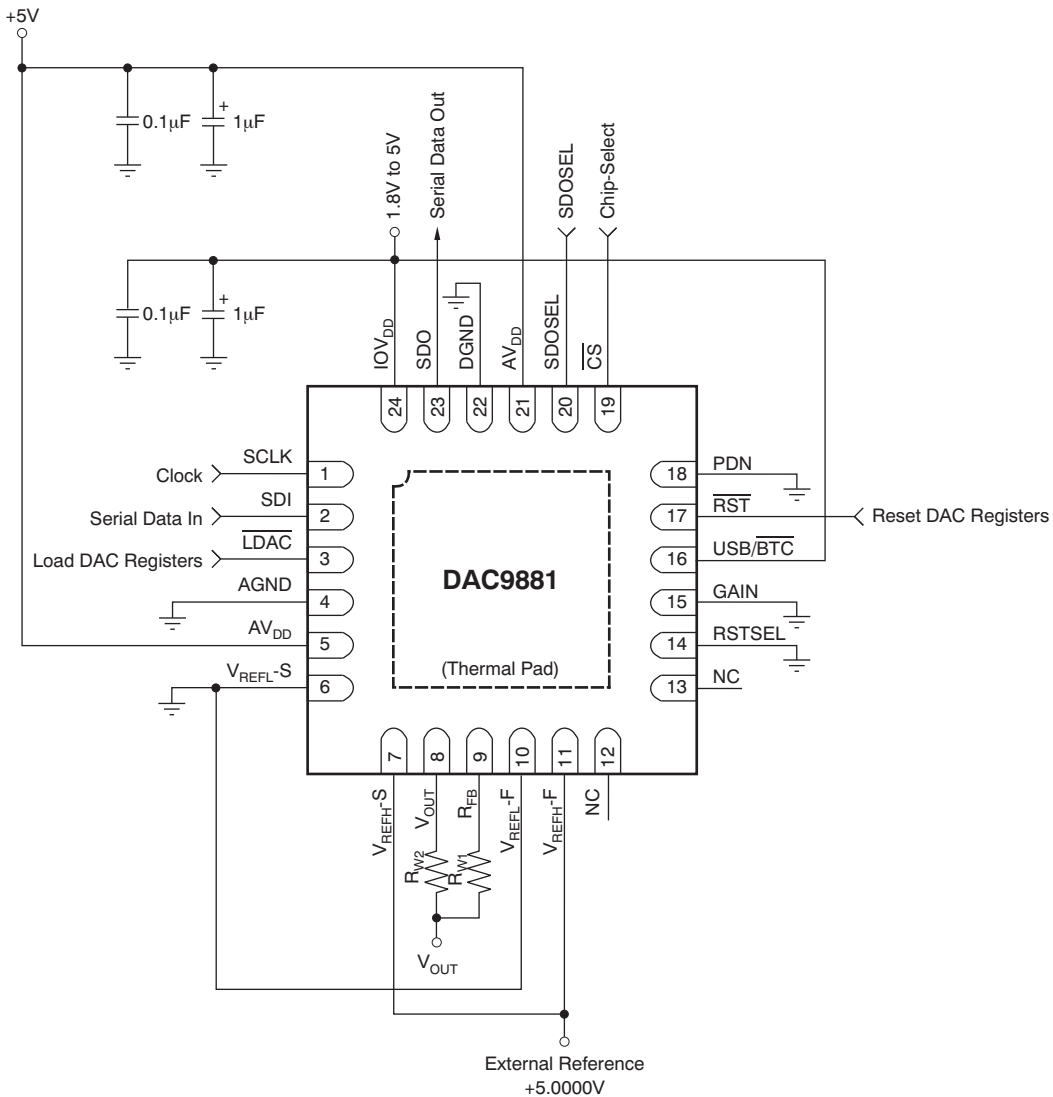

Figure 66. Analog Output Closed-Loop Configuration
 (R_{W1} and R_{W2} represent wiring resistance)

REFERENCE INPUTS

The reference high input, V_{REFH} , can be set to any voltage in the range of 1.25V to AV_{DD} . The reference low input, V_{REFL} , can be set to any voltage in the range of $-0.2V$ to $+0.2V$ (to provide a small offset to the output of the DAC9881, if desired). The current into V_{REFH} and out of V_{REFL} depends on the DAC code, and can vary from approximately 0.5mA to 1mA in the gain = 1X mode of operation. The reference high and low inputs appear as variable loads to the external reference circuit. If the external references can source or sink the required current, and if low impedance connections are made to the V_{REFH} and V_{REFL} pins, external reference buffers are not required. Figure 65 shows a simple configuration of the DAC9881 using external references without force and sense reference buffers.

Kelvin sense connections for the reference high and low are included on the DAC9881. When properly used with external reference buffer op amps, these reference Kelvin sense pins ensure that the driven reference high and low voltages remain stable versus varying reference load currents. Figure 67 shows an example of a reference force and sense configuration of the DAC9881 operating from a single analog reference voltage. Both the V_{REFL} and V_{REFH} reference voltages are set to levels of 100mV from the DAC9881 supply rails, and are derived from a +5V external reference. Figure 68 illustrates the effect of not using the reference force and sense buffers to drive the DAC9881 V_{REFL} and V_{REFH} pins. Figure 69 shows the improvement when using the reference buffers. A slight degradation in INL and DNL performance is seen without the use of the force and sense buffer configuration.

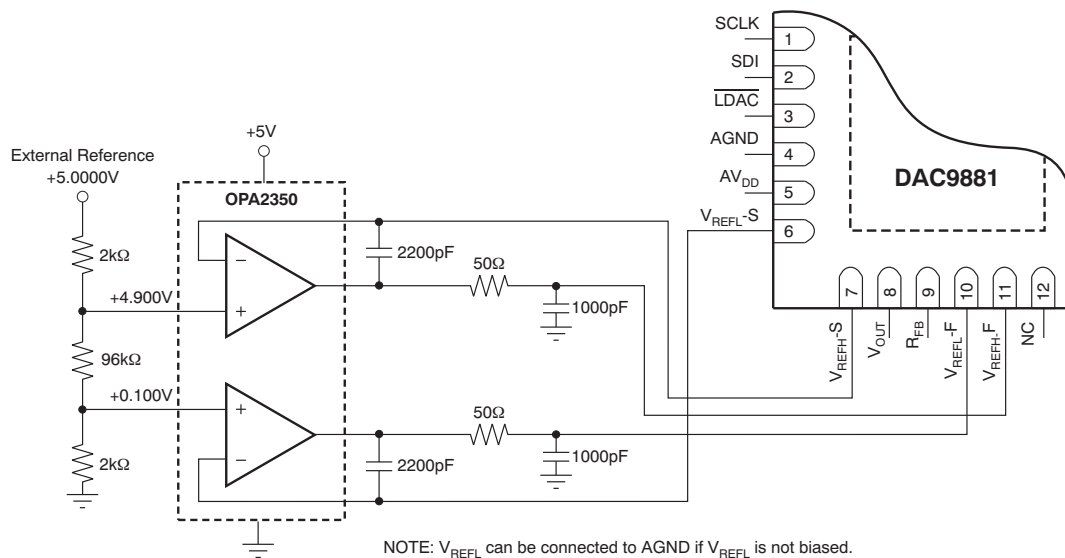

Figure 67. Buffered References ($V_{REFH} = +4.900V$ and $V_{REFL} = 100mV$).

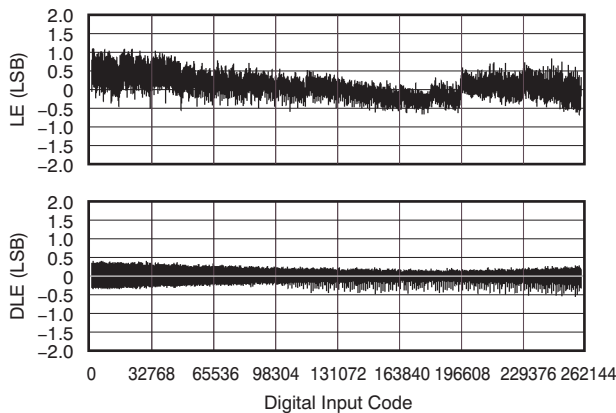

Figure 68. Linearity and Differential Linearity Error for Figure 65 without Reference Buffers

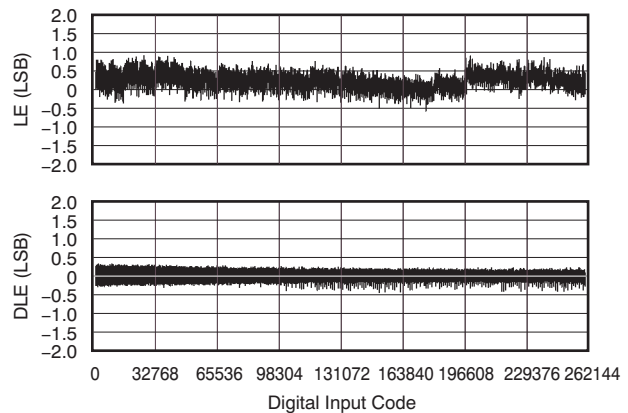

Figure 69. Linearity and Differential Linearity Error for Figure 67 with Reference Buffers

OUTPUT RANGE

The maximum output range of the DAC9881 is V_{REFL} to $(V_{REFH} - V_{REFL}) \times G$, where G is the output buffer gain set by the GAIN pin. When the GAIN pin is connected to DGND, the output buffer gain = 1. When the GAIN pin is connected to IOV_{DD}, the output buffer gain = 2. The output range must not be greater than AV_{DD}; otherwise, output saturation occurs. The DAC9881 output transfer function is given in [Equation 1](#):

$$V_{OUT} = \frac{V_{REFH} - V_{REFL}}{262144} \times \text{CODE} \times \text{Buffer Gain} + V_{REFL} \quad (1)$$

Where:

CODE = 0 to 262143. This is the digital code loaded to the DAC.

Buffer Gain = 1 or 2 (set by the GAIN pin).

V_{REFH} = reference high voltage applied to the device.

V_{REFL} = reference low voltage applied to the device.

INPUT DATA FORMAT

The USB/ $\overline{\text{BTC}}$ pin defines the input data format. When this pin is connected to IOV_{DD}, the input data format is straight binary, as shown in [Table 1](#). When this pin is connected to DGND, the input data format is twos complement, as shown in [Table 2](#).

Table 1. Output vs Straight Binary Code

USB CODE	5V RANGE	DESCRIPTION
3FFFFh	+4.99998	+Full-Scale – 1LSB
30000h	+3.75000	3/4-Scale
20000h	+2.50000	Midscale
10000h	+1.25000	1/4-Scale
00000h	0.00000	Zero-Scale

Table 2. Output vs Twos Complement Code

$\overline{\text{BTC}}$ CODE	5V RANGE	DESCRIPTION
1FFFFh	+4.99998	+Full-Scale – 1LSB
10000h	+3.75000	3/4-Scale
00000h	+2.50000	Midscale
3FFFFh	+2.49998	Midscale – 1LSB
30000h	+1.25000	1/4-Scale
20000h	0.00000	Zero-Scale

POWER DOWN

The DAC9881 has a hardware power-down function. When the PDN pin is high, the device is in power-down mode. When the device is in power-down, the V_{OUT} pin is connected to ground through an internal 10k Ω resistor, but the contents of the input register and the DAC latch do not change and SPI communication remains active. When the PDN pin returns low, the device returns to normal operation.

HARDWARE RESET

When the $\overline{\text{RST}}$ pin is low, the device is in hardware reset mode, and the input register and DAC latch are set to the value defined by the RSTSEL pin. After $\overline{\text{RST}}$ goes high, the device is in normal operating mode, and the input register and DAC latch maintain the reset value until new data are written.

POWER-ON RESET

The DAC9881 has a power-on reset function. After power-on, the value of the input register, the DAC latch, and the output from the V_{OUT} pin are set to the value defined by the RSTSEL pin.

PROGRAM RESET VALUE

After a power-on reset or a hardware reset, the output voltage from the V_{OUT} pin and the values of the input register and DAC latch are determined by the status of the RSTSEL pin and the input data format, as shown in [Table 3](#).

Table 3. Reset Value

RSTSEL PIN	USB/BTC PIN	INPUT FORMAT	V_{OUT}	VALUE OF INPUT REGISTER AND DAC LATCH
DGND	IOV_{DD}	Straight Binary	0	00000h
IOV_{DD}	IOV_{DD}	Straight Binary	Midscale	20000h
DGND	DGND	Twos Complement	Midscale	00000h
IOV_{DD}	DGND	Twos Complement	0	20000h

SERIAL INTERFACE

The DAC9881 is controlled by a versatile three-wire serial interface that operates at clock rates of up to 50MHz and is compatible with SPI, QSPI™, MICROWIRE™, and DSP interface standards.

Input Shift Register

Data are loaded into the device as a 24-bit word under the control of the serial clock input, SCLK. The timing diagrams for this operation are shown in the [Timing Diagram](#) section.

The \overline{CS} input is a level-triggered input that acts as a frame synchronization signal and chip enable. Data can be transferred into the device only while \overline{CS} is low. When \overline{CS} is high, the SCLK and SDI signals are blocked out, and SDO is in high-Z status. To start the serial data transfer, \overline{CS} should be taken low, observing the minimum delay from \overline{CS} falling edge to SCLK rising edge, t_2 . After \overline{CS} goes low, serial input data from SDI are clocked into the device input shift register on the rising edges of SCLK for 24 or more clock pulses. If a frame contains less than 24 bits of data, the frame is invalid. Invalid input data are not written into the input register and DAC, although the input register and DAC will continue to hold data from the preceding valid data cycle. If more than 24 bits of data are transmitted in one frame, the last 24 bits are written into the shift register and DAC. \overline{CS} may be taken high after the rising edge of the 24th SCLK pulse, observing the minimum SCLK rising edge to \overline{CS} rising edge time, t_7 . The contents of the shift register are transferred into the input register on the rising edge of \overline{CS} . When data have been transferred into the input register of the DAC, the corresponding DAC register and DAC output can be updated by taking the \overline{LDAC} pin low. [Table 4](#) shows the input shift register data word format. D17 is the MSB of the 18-bit DAC data.

Table 4. Input Shift Register Data Word Format

BIT	B23	B22	B21	B20	B19	B18	B17 (MSB)	B16	B15	B14	B13	B12	B11	B10	B9	B8	B7	B6	B5	B4	B3	B2	B1	B0 (LSB)
DATA	X ⁽¹⁾	X	X	X	X	X	D17	D16	D15	D14	D13	D12	D11	D10	D9	D8	D7	D6	D5	D4	D3	D2	D1	D0

(1) X = don't care.

Stand-Alone Mode

When the SDOSEL pin is tied to IOV_{DD} , the interface is in Stand-Alone mode. This mode provides serial readback for diagnostic purposes. The new input data (24 bits) are clocked into the device shift register and the existing data in the input register (24 bits) are shifted out from the SDO pin. If more than 24 SCLKs are clocked when \overline{CS} is low, the contents of the input register are shifted out from the SDO pin, followed by zeroes; the last 24 bits of input data remain in the shift register. If less than 24 SCLKs are clocked while \overline{CS} is low, the data from the SDO pin are part of the data in the input register and must be ignored. Refer to [Figure 2](#) for further details.

Daisy-Chain Mode

When the SDOSEL pin is tied to GND, the interface is in Daisy-Chain mode. For systems that contain several DACs, the SDO pin may be used to daisy-chain several devices together.

In Daisy-Chain mode, SCLK is continuously applied to the input shift register while \overline{CS} is low. If more than 24 clock pulses are applied, the data ripple out of the shift register and appear on the SDO line. These data are clocked out on the falling edge of SCLK and are valid on the rising edge. By connecting this line to the SDI input on the next DAC in the chain, a multi-DAC interface is constructed. 24 clock pulses are required for each DAC in the chain. Therefore, the total number of clock cycles must be equal to $(24 \times N)$, where N is the total number of devices in the chain. When the serial transfer to all devices is complete, \overline{CS} should be taken high. This action prevents any further data from being clocked into the input shift register. The contents in the shift registers are transferred into the relevant input registers on the rising edge of the \overline{CS} signal.

A continuous SCLK source may be used if \overline{CS} can be held low for the correct number of clock cycles. Alternatively, a burst clock containing the exact number of clock cycles can be used and \overline{CS} can be taken high some time later. When the transfer to all input registers is complete, a common LDAC signal updates all DAC registers, and all analog outputs update simultaneously.

DOUBLE-BUFFERED INTERFACE

The DAC9881 has a double-buffered interface consisting of two register banks: the input register and the DAC latch. The input register is connected directly to the input shift register and the digital code is transferred to the input register upon completion of a valid write sequence. The DAC latch contains the digital code used by the resistor R-2R ladder. The contents of the DAC latch defines the output from the DAC.

Access to the DAC latch is controlled by the \overline{LDAC} pin. When \overline{LDAC} is high, the DAC latch is latched and the input register can change state without affecting the contents of the DAC latch. When \overline{LDAC} is low, however, the DAC latch becomes transparent and the contents of the input register is transferred to the DAC register.

Load DAC Pin (\overline{LDAC})

\overline{LDAC} transfers data from the input register to the DAC latch (and, therefore, updates the DAC output). The contents of the DAC latch (and the output from DAC) can be changed in two ways, depending on the status of \overline{LDAC} .

Synchronous Mode

When \overline{LDAC} is tied low, the DAC latch updates as soon as new data are transferred into the input register after the rising edge of \overline{CS} .

Asynchronous Mode

When \overline{LDAC} is high, the DAC latch is latched. The DAC latch (and DAC output) is not updated at the same time that the input register is written to. When \overline{LDAC} goes low, the DAC latch updates with the contents of the input register.

1.8V TO 5V LOGIC INTERFACE

All digital input and output pins are compatible with any logic supply voltage between 1.8V and 5V. Connect the interface logic supply voltage to the IOV_{DD} pin. Although timing is specified down to 2.7V (see the [Timing Characteristics](#)), IOV_{DD} can operate as low as 1.8V, but with degraded timing and temperature performance. For the lowest power consumption, logic V_{IH} levels should be as close as possible to IOV_{DD}, and logic V_{IL} levels should be as close as possible to GND.

POWER-SUPPLY SEQUENCE

For the device to work properly, IOVDD must not come up before AV_{DD}, and the reference voltage must come up after the AV_{DD} supply. Additionally, because the DAC input shift register is not reset during a power-on reset or hardware reset, the \overline{CS} pin must not be unintentionally asserted during power-up of the device. To avoid improper power-up, it is recommended that the \overline{CS} and \overline{LDAC} pins be connected to IOV_{DD} through pull-up resistors. To ensure that the electrostatic discharge (ESD) protection circuitry of this device is not activated, all other digital pins must be held at ground potential until IOV_{DD} is applied.

APPLICATION INFORMATION

BIPOLAR OPERATION USING THE DAC9881

The DAC9881 is designed for single-supply operation; however, a bipolar output is also possible using the circuit shown in [Figure 70](#). This circuit gives a bipolar output voltage of V_{BIP} . When $GAIN = 1$, V_{BIP} can be calculated using [Equation 2](#):

$$V_{BIP}(CODE) = \left[1 + \frac{R_3}{R_2} + \frac{R_3}{R_1} \right] \times \left[\frac{CODE}{262144} - \frac{R_3}{R_1} \right] \times V_{REF} \quad (2)$$

Where:

$V_{BIP}(CODE)$ = bipolar output voltage versus CODE from the [OPA211](#).

CODE = 0 to 262143. This is the digital code loaded to the DAC.

V_{REF} = reference high voltage applied to the DAC9881.

By first choosing a value for resistor R_3 , R_1 and R_2 can be determined by [Equation 3](#) and [Equation 4](#), respectively:

$$R_1 = \frac{V_{REF}}{V_{BIP}} \times R_3 \quad (3)$$

$$R_2 = \frac{V_{REF} \times R_3}{V_{BIP} - V_{REF}} \quad (4)$$

Where:

V_{BIP} = peak desired output voltage for bipolar output.

V_{REF} = reference high voltage applied to the DAC9881. NOTE: $V_{BIP} \geq V_{REF}$.

R_3 = OPA211 feedback resistor chosen by user.

Note that R_2 is not required in the circuit of [Figure 70](#) for bipolar output voltage ranges equal to $\pm V_{REF}$.

Using the previous equations, and with $V_{REF} = 5V$ and R_3 set to $10k\Omega$, a $\pm 8V$ output span can be achieved with R_1 calculated to be $6.25k\Omega$ and R_2 to be $16.67k\Omega$.



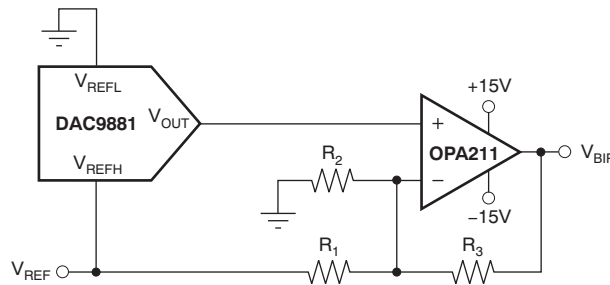

Similarly, a near $\pm 15V$ rail-to-rail output can be achieved with R_1 calculated to be $3.33k\Omega$ and R_2 calculated to be $5k\Omega$.



NOTE: Some pins omitted for clarity.

Figure 70. Bipolar Operation Using the DAC9881

PACKAGING INFORMATION

Orderable Device	Status (1)	Package Type	Package Drawing	Pins	Package Qty	Eco Plan (2)	Lead/Ball Finish (6)	MSL Peak Temp (3)	Op Temp (°C)	Device Marking (4/5)	Samples
DAC9881SBRGER	ACTIVE	VQFN	RGE	24	3000	Green (RoHS & no Sb/Br)	CU NIPDAU	Level-2-260C-1 YEAR	-40 to 105	DAC 9881 B	
DAC9881SBRGET	ACTIVE	VQFN	RGE	24	250	Green (RoHS & no Sb/Br)	CU NIPDAU	Level-2-260C-1 YEAR	-40 to 105	DAC 9881 B	
DAC9881SRGER	ACTIVE	VQFN	RGE	24	3000	Green (RoHS & no Sb/Br)	CU NIPDAU	Level-2-260C-1 YEAR	-40 to 105	DAC 9881	
DAC9881SRGET	ACTIVE	VQFN	RGE	24	250	Green (RoHS & no Sb/Br)	CU NIPDAU	Level-2-260C-1 YEAR	-40 to 105	DAC 9881	
DAC9881SRGETG4	ACTIVE	VQFN	RGE	24	250	Green (RoHS & no Sb/Br)	CU NIPDAU	Level-2-260C-1 YEAR	-40 to 105	DAC 9881	

(1) The marketing status values are defined as follows:

ACTIVE: Product device recommended for new designs.

LIFEBUY: TI has announced that the device will be discontinued, and a lifetime-buy period is in effect.

NRND: Not recommended for new designs. Device is in production to support existing customers, but TI does not recommend using this part in a new design.

PREVIEW: Device has been announced but is not in production. Samples may or may not be available.

OBSOLETE: TI has discontinued the production of the device.

(2) Eco Plan - The planned eco-friendly classification: Pb-Free (RoHS), Pb-Free (RoHS Exempt), or Green (RoHS & no Sb/Br) - please check <http://www.ti.com/productcontent> for the latest availability information and additional product content details.

TBD: The Pb-Free/Green conversion plan has not been defined.

Pb-Free (RoHS): TI's terms "Lead-Free" or "Pb-Free" mean semiconductor products that are compatible with the current RoHS requirements for all 6 substances, including the requirement that lead not exceed 0.1% by weight in homogeneous materials. Where designed to be soldered at high temperatures, TI Pb-Free products are suitable for use in specified lead-free processes.

Pb-Free (RoHS Exempt): This component has a RoHS exemption for either 1) lead-based flip-chip solder bumps used between the die and package, or 2) lead-based die adhesive used between the die and leadframe. The component is otherwise considered Pb-Free (RoHS compatible) as defined above.

Green (RoHS & no Sb/Br): TI defines "Green" to mean Pb-Free (RoHS compatible), and free of Bromine (Br) and Antimony (Sb) based flame retardants (Br or Sb do not exceed 0.1% by weight in homogeneous material)

(3) MSL, Peak Temp. - The Moisture Sensitivity Level rating according to the JEDEC industry standard classifications, and peak solder temperature.

(4) There may be additional marking, which relates to the logo, the lot trace code information, or the environmental category on the device.

(5) Multiple Device Markings will be inside parentheses. Only one Device Marking contained in parentheses and separated by a "~" will appear on a device. If a line is indented then it is a continuation of the previous line and the two combined represent the entire Device Marking for that device.

⁽⁶⁾ Lead/Ball Finish - Orderable Devices may have multiple material finish options. Finish options are separated by a vertical ruled line. Lead/Ball Finish values may wrap to two lines if the finish value exceeds the maximum column width.

Important Information and Disclaimer: The information provided on this page represents TI's knowledge and belief as of the date that it is provided. TI bases its knowledge and belief on information provided by third parties, and makes no representation or warranty as to the accuracy of such information. Efforts are underway to better integrate information from third parties. TI has taken and continues to take reasonable steps to provide representative and accurate information but may not have conducted destructive testing or chemical analysis on incoming materials and chemicals. TI and TI suppliers consider certain information to be proprietary, and thus CAS numbers and other limited information may not be available for release.

In no event shall TI's liability arising out of such information exceed the total purchase price of the TI part(s) at issue in this document sold by TI to Customer on an annual basis.

TAPE AND REEL INFORMATION

QUADRANT ASSIGNMENTS FOR PIN 1 ORIENTATION IN TAPE

*All dimensions are nominal

Device	Package Type	Package Drawing	Pins	SPQ	Reel Diameter (mm)	Reel Width W1 (mm)	A0 (mm)	B0 (mm)	K0 (mm)	P1 (mm)	W (mm)	Pin1 Quadrant
DAC9881SBRGER	VQFN	RGE	24	3000	330.0	12.4	4.3	4.3	1.5	8.0	12.0	Q2
DAC9881SBRGET	VQFN	RGE	24	250	180.0	12.4	4.3	4.3	1.5	8.0	12.0	Q2
DAC9881SRGER	VQFN	RGE	24	3000	330.0	12.4	4.3	4.3	1.5	8.0	12.0	Q2
DAC9881SRGET	VQFN	RGE	24	250	180.0	12.4	4.3	4.3	1.5	8.0	12.0	Q2

TAPE AND REEL BOX DIMENSIONS

*All dimensions are nominal

Device	Package Type	Package Drawing	Pins	SPQ	Length (mm)	Width (mm)	Height (mm)
DAC9881SBRGER	VQFN	RGE	24	3000	338.1	338.1	20.6
DAC9881SBRGET	VQFN	RGE	24	250	210.0	185.0	35.0
DAC9881SRGER	VQFN	RGE	24	3000	338.1	338.1	20.6
DAC9881SRGET	VQFN	RGE	24	250	210.0	185.0	35.0

THERMAL PAD MECHANICAL DATA

RGE (S-PVQFN-N24)

PLASTIC QUAD FLATPACK NO-LEAD

THERMAL INFORMATION

This package incorporates an exposed thermal pad that is designed to be attached directly to an external heatsink. The thermal pad must be soldered directly to the printed circuit board (PCB). After soldering, the PCB can be used as a heatsink. In addition, through the use of thermal vias, the thermal pad can be attached directly to the appropriate copper plane shown in the electrical schematic for the device, or alternatively, can be attached to a special heatsink structure designed into the PCB. This design optimizes the heat transfer from the integrated circuit (IC).

For information on the Quad Flatpack No-Lead (QFN) package and its advantages, refer to Application Report, QFN/SON PCB Attachment, Texas Instruments Literature No. SLUA271. This document is available at www.ti.com.

The exposed thermal pad dimensions for this package are shown in the following illustration.

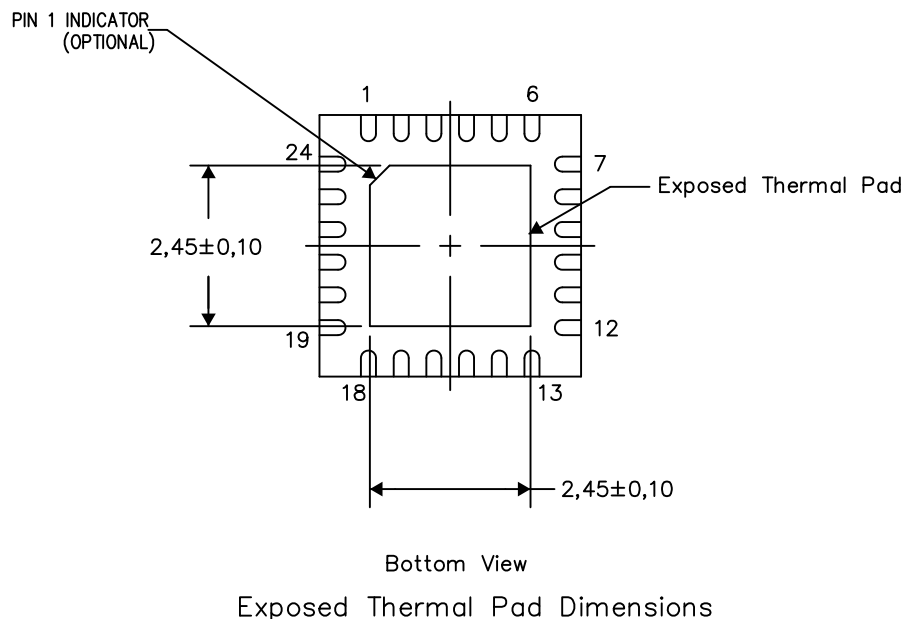

4206344-3/AK 08/15

NOTES: A. All linear dimensions are in millimeters

RGE (S-PVQFN-N24)

PLASTIC QUAD FLATPACK NO-LEAD

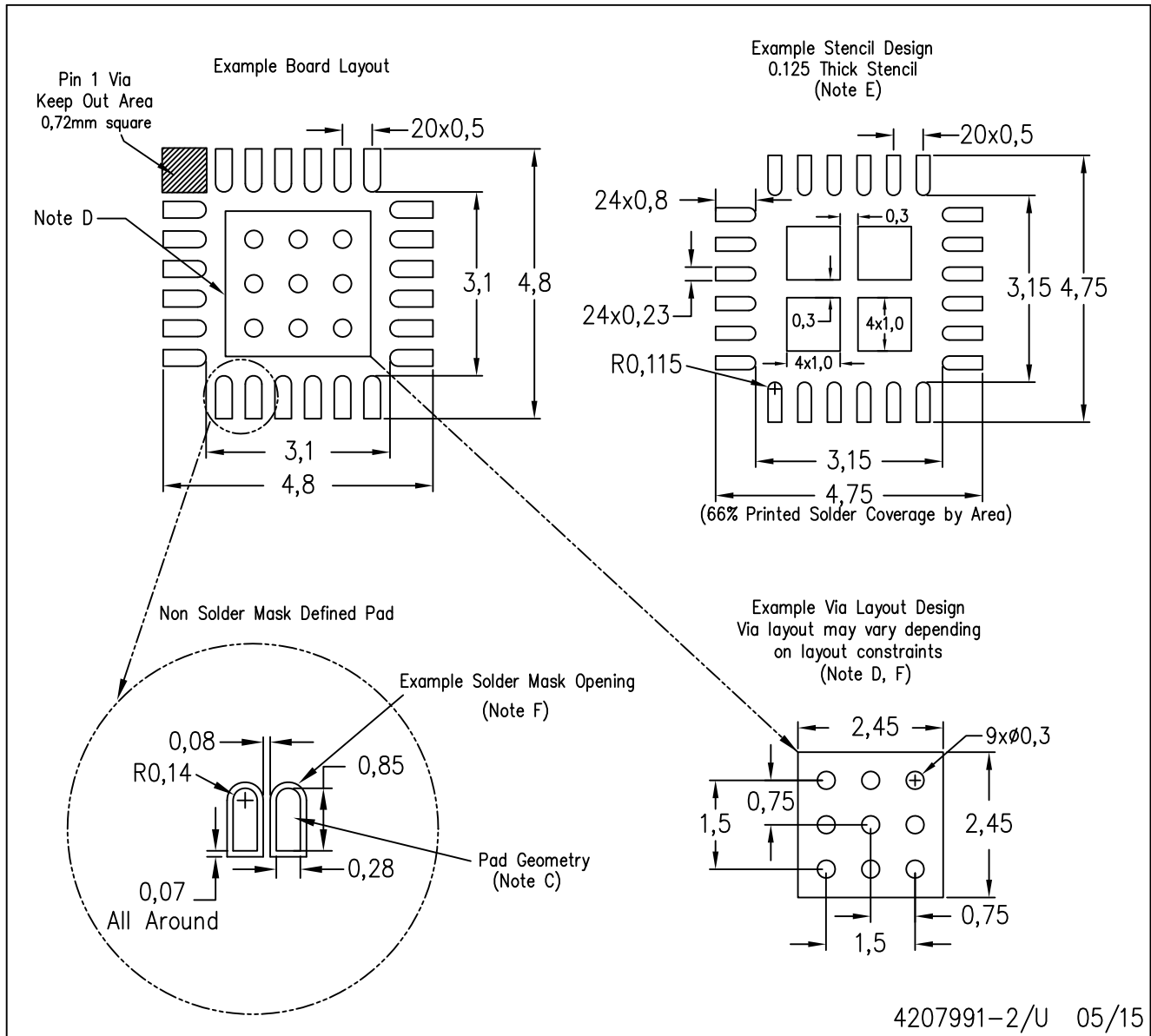

- NOTES:
- All linear dimensions are in millimeters.
 - This drawing is subject to change without notice.
 - Publication IPC-7351 is recommended for alternate designs.
 - This package is designed to be soldered to a thermal pad on the board. Refer to Application Note, Quad Flat-Pack Packages, Texas Instruments Literature No. SLUA271, and also the Product Data Sheets for specific thermal information, via requirements, and recommended board layout. These documents are available at www.ti.com <<http://www.ti.com>>.
 - Laser cutting apertures with trapezoidal walls and also rounding corners will offer better paste release. Customers should contact their board assembly site for stencil design recommendations. Refer to IPC 7525 for stencil design considerations.
 - Customers should contact their board fabrication site for recommended solder mask tolerances and via tenting recommendations for vias placed in the thermal pad.

IMPORTANT NOTICE

Texas Instruments Incorporated and its subsidiaries (TI) reserve the right to make corrections, enhancements, improvements and other changes to its semiconductor products and services per JESD46, latest issue, and to discontinue any product or service per JESD48, latest issue. Buyers should obtain the latest relevant information before placing orders and should verify that such information is current and complete. All semiconductor products (also referred to herein as "components") are sold subject to TI's terms and conditions of sale supplied at the time of order acknowledgment.

TI warrants performance of its components to the specifications applicable at the time of sale, in accordance with the warranty in TI's terms and conditions of sale of semiconductor products. Testing and other quality control techniques are used to the extent TI deems necessary to support this warranty. Except where mandated by applicable law, testing of all parameters of each component is not necessarily performed.

TI assumes no liability for applications assistance or the design of Buyers' products. Buyers are responsible for their products and applications using TI components. To minimize the risks associated with Buyers' products and applications, Buyers should provide adequate design and operating safeguards.

TI does not warrant or represent that any license, either express or implied, is granted under any patent right, copyright, mask work right, or other intellectual property right relating to any combination, machine, or process in which TI components or services are used. Information published by TI regarding third-party products or services does not constitute a license to use such products or services or a warranty or endorsement thereof. Use of such information may require a license from a third party under the patents or other intellectual property of the third party, or a license from TI under the patents or other intellectual property of TI.

Reproduction of significant portions of TI information in TI data books or data sheets is permissible only if reproduction is without alteration and is accompanied by all associated warranties, conditions, limitations, and notices. TI is not responsible or liable for such altered documentation. Information of third parties may be subject to additional restrictions.

Resale of TI components or services with statements different from or beyond the parameters stated by TI for that component or service voids all express and any implied warranties for the associated TI component or service and is an unfair and deceptive business practice. TI is not responsible or liable for any such statements.

Buyer acknowledges and agrees that it is solely responsible for compliance with all legal, regulatory and safety-related requirements concerning its products, and any use of TI components in its applications, notwithstanding any applications-related information or support that may be provided by TI. Buyer represents and agrees that it has all the necessary expertise to create and implement safeguards which anticipate dangerous consequences of failures, monitor failures and their consequences, lessen the likelihood of failures that might cause harm and take appropriate remedial actions. Buyer will fully indemnify TI and its representatives against any damages arising out of the use of any TI components in safety-critical applications.

In some cases, TI components may be promoted specifically to facilitate safety-related applications. With such components, TI's goal is to help enable customers to design and create their own end-product solutions that meet applicable functional safety standards and requirements. Nonetheless, such components are subject to these terms.

No TI components are authorized for use in FDA Class III (or similar life-critical medical equipment) unless authorized officers of the parties have executed a special agreement specifically governing such use.

Only those TI components which TI has specifically designated as military grade or "enhanced plastic" are designed and intended for use in military/aerospace applications or environments. Buyer acknowledges and agrees that any military or aerospace use of TI components which have **not** been so designated is solely at the Buyer's risk, and that Buyer is solely responsible for compliance with all legal and regulatory requirements in connection with such use.

TI has specifically designated certain components as meeting ISO/TS16949 requirements, mainly for automotive use. In any case of use of non-designated products, TI will not be responsible for any failure to meet ISO/TS16949.

Products

Audio	www.ti.com/audio
Amplifiers	amplifier.ti.com
Data Converters	dataconverter.ti.com
DLP® Products	www.dlp.com
DSP	dsp.ti.com
Clocks and Timers	www.ti.com/clocks
Interface	interface.ti.com
Logic	logic.ti.com
Power Mgmt	power.ti.com
Microcontrollers	microcontroller.ti.com
RFID	www.ti-rfid.com
OMAP Applications Processors	www.ti.com/omap
Wireless Connectivity	www.ti.com/wirelessconnectivity

Applications

Automotive and Transportation	www.ti.com/automotive
Communications and Telecom	www.ti.com/communications
Computers and Peripherals	www.ti.com/computers
Consumer Electronics	www.ti.com/consumer-apps
Energy and Lighting	www.ti.com/energy
Industrial	www.ti.com/industrial
Medical	www.ti.com/medical
Security	www.ti.com/security
Space, Avionics and Defense	www.ti.com/space-avionics-defense
Video and Imaging	www.ti.com/video

TI E2E Community

e2e.ti.com