



DirectPath™, Pop-Free 3Vrms Line Driver with Adjustable Gain

 Check for Samples: [DRV602](#)

FEATURES

- **DirectPath™**
 - Eliminates Pop/Clicks
 - Eliminates Output DC-Blocking Capacitors
 - Provides Flat Frequency Response 20Hz–20kHz
- **Low Noise and THD**
 - SNR > 102 dB
 - Typical $V_N < 15 \mu\text{Vms}$
 - THD+N < 0.05% 20 Hz–20 kHz
- **Output Voltage into 2.5-k Ω Load**
 - 2 Vrms with 3.3-V Supply Voltage
 - 3 Vrms with 5-V Supply Voltage
- **3Vrms Output Voltage into 2.5 k Ω Load With 5V Supply Voltage**
- **Differential Input**

APPLICATIONS

- Set-Top Boxes
- PDP / LCD TV
- Blu-ray Disc™, DVD-Players
- Home Theater in a Box

DESCRIPTION

The DRV602PW is a 3Vrms pop-free stereo line driver designed to allow the removal of the output dc-blocking capacitors for reduced component count and cost. The device is ideal for single supply electronics where size and cost are critical design parameters.

Designed using TI's patented DirectPath™ technology, the DRV602 is capable of driving 3Vrms into a 2.5k Ω load with 5V supply voltage. The device has differential inputs and uses external gain setting resistors, that supports a gain range of $\pm 1\text{V/V}$ to $\pm 10\text{V/V}$. The use of external gain resistors also allows the implementation of a 2nd order low pass filter to compliment DAC's and SOC converters. The line output of the DRV602 has $\pm 8\text{kV}$ IEC ESD protection. The DRV602 (referred to as the '602) has built-in shutdown control for pop-free on/off control.

Using the DRV602 in audio products can reduce component count compared to traditional methods of generating a 3Vrms output. The DRV602 doesn't require a power supply greater than 5V to generate its 8.5V_{pp} output, nor does it require a split rail power supply. The DRV602 integrates its own charge pump to generate a negative supply rail that provides a clean, pop-free ground biased 3Vrms output.

The DRV602 is available in a 14 pin TSSOP package.

If higher SNR, trimmed DC-offset and external undervoltage-mute functions are beneficial in the application, TI recommends the footprint compatible DRV603 ([SLOS617](#)).

For a stereo line and stereo HP driver see DRV604 ([SLOS659](#)).

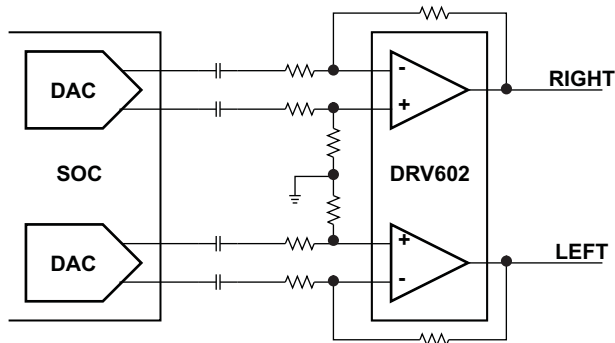

Please be aware that an important notice concerning availability, standard warranty, and use in critical applications of Texas Instruments semiconductor products and disclaimers thereto appears at the end of this data sheet.

DirectPath, TI FilterPro are trademarks of Texas Instruments.

Blu-ray Disc is a trademark of Blu-ray Disc Association.

All other trademarks are the property of their respective owners.



These devices have limited built-in ESD protection. The leads should be shorted together or the device placed in conductive foam during storage or handling to prevent electrostatic damage to the MOS gates.

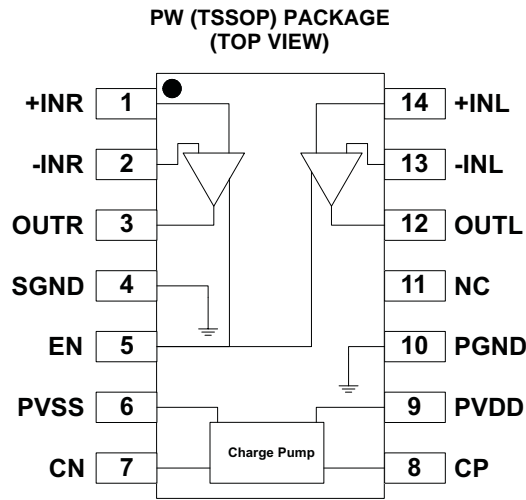

PIN FUNCTIONS

PIN		I/O ⁽¹⁾	DESCRIPTION
NAME	TSSOP (PW)		
+INR	1	I	Right channel OPAMP positive input
-INR	2	I	Right channel OPAMP negative input
OTR	3	O	Right channel OPAMP output
SGND	4	I	Signal ground
EN	5	I	Enable input, active high
PVSS	6	O	Supply voltage
CN	7	I/O	Charge pump flying capacitor negative terminal
CP	8	I/O	Charge pump flying capacitor positive terminal
PVDD	9	I	Positive supply
PGND	10	I	Power ground
NC	11		No internal connection
OUTL	12	O	Left channel OPAMP output
-INL	13	I	Left channel OPAMP negative input
+INL	14	I	Left channel OPAMP positive input

(1) I = input, O = output, P = power

ABSOLUTE MAXIMUM RATINGS^{(1) (2)}

over operating free-air temperature range

	VALUE	UNIT
Supply voltage, VDD to GND	–0.3 V to 5.5	V
V _I Input voltage	V _{SS} – 0.3 to V _{DD} + 0.3	V
R _L Minimum load impedance	> 600	Ω
EN to GND	–0.3 to V _{DD} +0.3	V
T _J Maximum operating junction temperature range,	–40 to 150	°C
T _{stg} Storage temperature range	–40 to 150	°C
ESD IEC Contact ESD Protection per IEC6100-4-2, on output pins measured on DRV602EVM	±8	kV

- (1) Stresses beyond those listed under *absolute maximum ratings* may cause permanent damage to the device. These are stress ratings only, and functional operation of the device at these or any other conditions beyond those indicated under *recommended operating conditions* is not implied. Exposure to absolute-maximum-rated conditions for extended periods may affect device reliability.
- (2) These voltages represents the DC voltage + peak AC waveform measured at the terminal of the device in all conditions.

DISSIPATION RATINGS

PACKAGE	θ _{JC} (°/W)	θ _{JA} (°/W)	POWER RATING ⁽¹⁾ AT T _A ≤ 25°C	POWER RATING ⁽¹⁾ AT T _A ≤ 70°C
TSSOP-14 (PW)	35	115 ⁽²⁾	870mW	348mW

- (1) Power rating is determined with a junction temperature of 125°C. This is the point where performance starts to degrade and long-term reliability starts to be reduced. Thermal management of the final PCB should strive to keep the junction temperature at or below 125°C for best performance and reliability.
- (2) These data were taken with the JEDEC High-K test printed circuit board (PCB). For the JEDEC low-K test PCB, the θ_{JA} is 185°C.

ORDERING INFORMATION

T _A	PACKAGE ⁽¹⁾	DESCRIPTION
–40°C to 85°C	DRV602PW	14-Pin TSSOP

- (1) For the most current package and ordering information, see the Package Option Addendum at the end of this document, or see the TI website at www.ti.com.

RECOMMENDED OPERATING CONDITIONS

	MIN	TYP	MAX	UNIT
V _{DD} Supply voltage, DC Supply Voltage	3	3.3	5.5	V
V _{IH} High-level input voltage		60		% of VDD
V _{IL} Low-level input voltage		40		% of VDD
T _A Operating free-air temperature	–40		85	°C

ELECTRICAL CHARACTERISTICS

 T_A = 25°C (unless otherwise noted)

PARAMETER	TEST CONDITIONS	MIN	TYP	MAX	UNIT
V _{OS} Output offset voltage	V _{DD} = 3 V to 5 V, Voltage follower - gain = 1			5	mV
PSRR Supply Rejection Ratio	V _{DD} = 3.3 V to 5 V		88		dB
V _{OH} High-level output voltage	V _{DD} = 3.3 V, R _L = 2.5 kΩ	3.10			V
V _{OL} Low-level output voltage	V _{DD} = 3.3 V, R _L = 2.5 kΩ			–3.05	V
I _{IH} High-level input current (EN)	V _{DD} = 5 V, V _I = V _{DD}			1	μA
I _{IL} Low-level input current (EN)	V _{DD} = 5 V, V _I = 0 V			1	μA
I _{DD} Supply Current	V _{DD} = 3.3 V, No load, EN = V _{DD}	8	11		mA
	V _{DD} = 5 V, No load, EN = V _{DD}		12.5	20	
	Shutdown mode, V _{DD} = 3 V to 5 V			2	mA

OPERATING CHARACTERISTICS

$V_{DD} = 3.3\text{ V}$, $T_A = 25^\circ\text{C}$, $R_L = 2.5\text{ k}\Omega$, $C_{(PUMP)} = C_{(PVSS)} = 1\ \mu\text{F}$, $C_{IN} = 1\ \mu\text{F}$, $R_{IN} = 33\ \text{k}\Omega$, $R_{fb} = 68\text{ k}\Omega$ (unless otherwise noted)

PARAMETER	TEST CONDITIONS	MIN	TYP	MAX	UNIT
V _O Output Voltage (Outputs In Phase)	THD = 1%, V _{DD} = 3.3 V, f = 1 kHz		2.05		V _{rms}
	THD = 1%, V _{DD} = 5 V, f = 1 kHz		3.01		
THD+N Total harmonic distortion plus noise	V _O = 2 V _{rms} , f = 1 kHz V _O = 2 V _{rms} , f = 6.8 kHz		0.01% 0.05%		
Crosstalk	V _O = 2 V _{rms} , f = 1 kHz		-100		dB
I _O Output current limit	V _{DD} = 3.3 V		20		mA
R _{IN} Input resistor range		1	10	47	k Ω
R _{fb} Feedback resistor range		4.7	20	100	k Ω
Slew rate			4.5		V/ μs
Maximum capacitive load			220		pF
V _N Noise output voltage	A-weighted, BW 20Hz–22kHz		15		μV_{rms}
SNR Signal to noise ratio	V _O = 2 V _{rms} , THD+N = 0.1%, 22 kHz BW, A-weighted		102		dB
G _{BW} Unity Gain Bandwidth			8		MHz
A _{VO} Open-loop voltage gain			150		dB
F _{cp} Charge Pump frequency		225	450	675	kHz

APPLICATION CIRCUIT

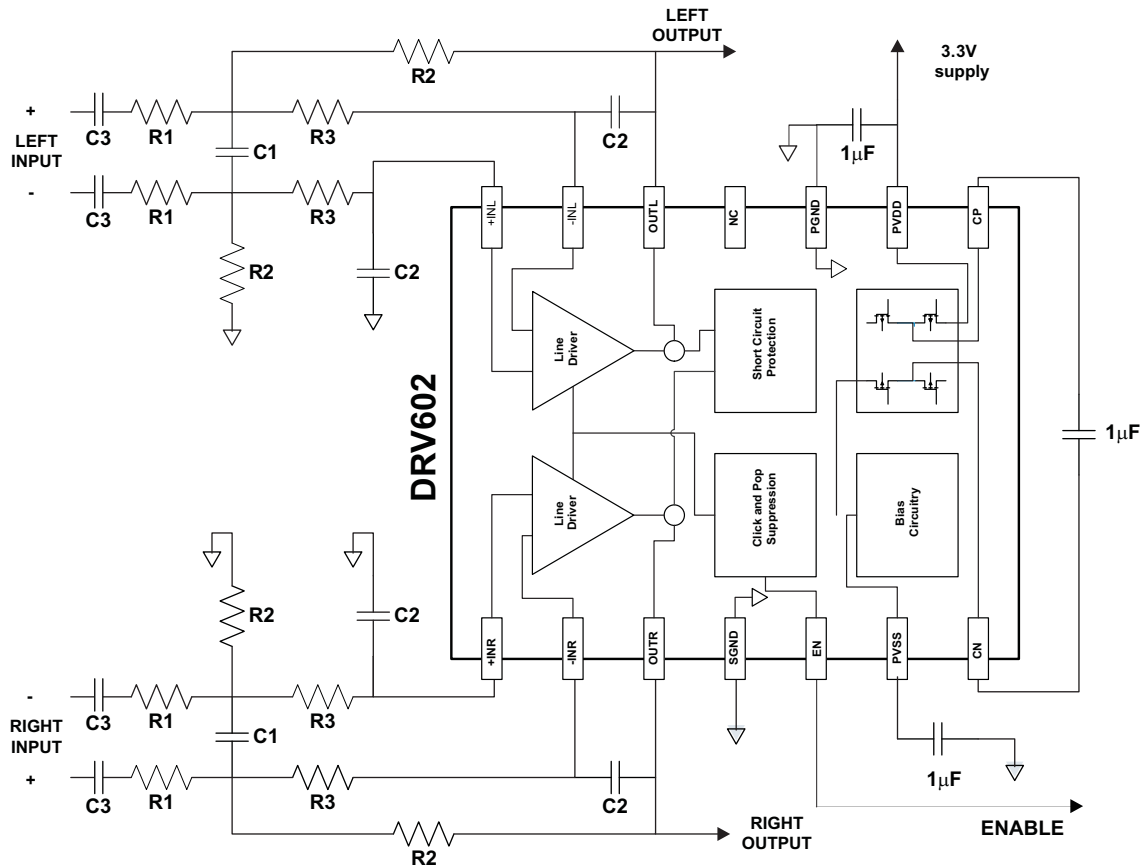

R1 = 33k Ω , R2 = 68k Ω , R3 = 100k Ω , C1 = 150pF, C2 = 15pF, C3 = 1 μF

Differential input, single ended output, 2nd order filter. 40kHz –3dB frequency, Gain 2.06.

TYPICAL CHARACTERISTICS

$V_{DD} = 3.3V$, $T_A = 25^\circ C$, $C_{(PUMP)} = C_{(PVSS)} = 1 \mu F$, $C_{IN} = 1 \mu F$, $R_{IN} = 33 k\Omega$, $R_{fb} = 68 k\Omega$, $R_L = 2.5 k\Omega$ (unless otherwise noted)

TOTAL HARMONIC DISTORTION + NOISE
vs
OUTPUT VOLTAGE

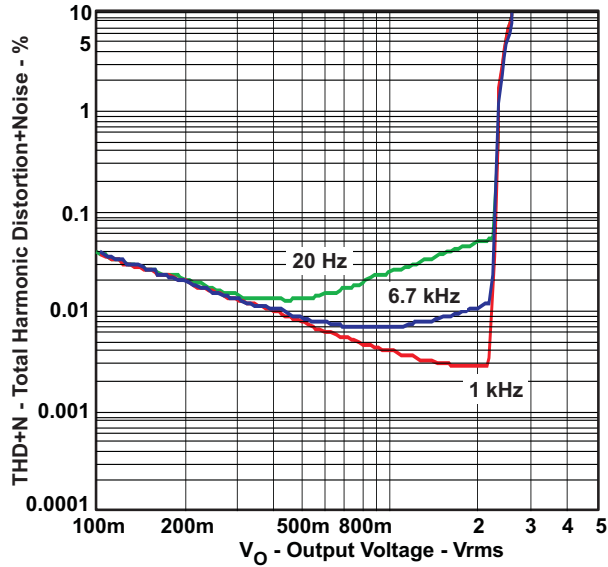

Figure 1.

TOTAL HARMONIC DISTORTION + NOISE
vs
FREQUENCY

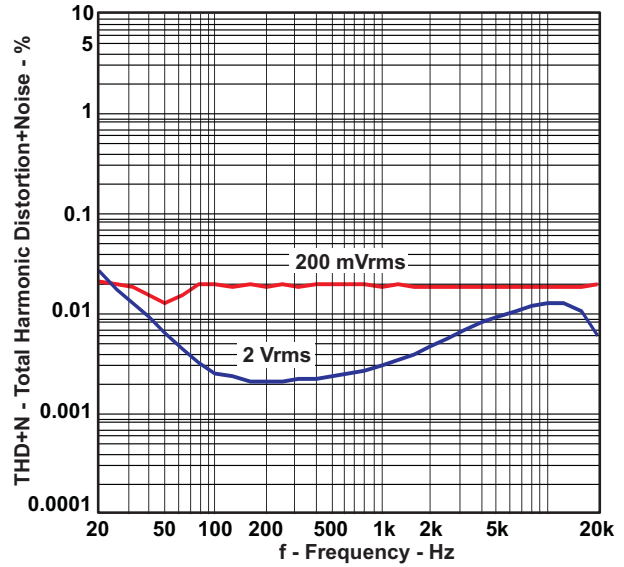

Figure 2.

FFT
vs
FREQUENCY

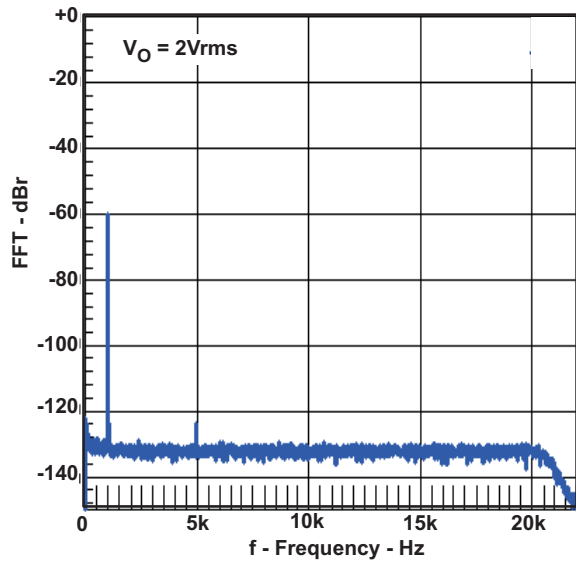

Figure 3.

QUIESCENT SUPPLY CURRENT
vs
SUPPLY VOLTAGE

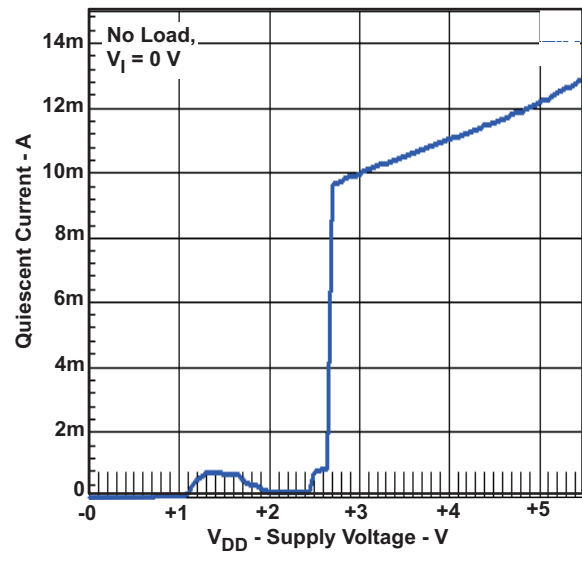

Figure 4.

APPLICATION INFORMATION

Line Driver Amplifiers

Single-supply line driver amplifiers typically require dc-blocking capacitors. The top drawing in [Figure 5](#) illustrates the conventional line driver amplifier connection to the load and output signal.

DC blocking capacitors are often large in value, and a mute circuit is needed during power up to minimize click & pop. The output capacitor and mute circuit consume PCB area and increase cost of assembly, and can reduce the fidelity of the audio output signal.

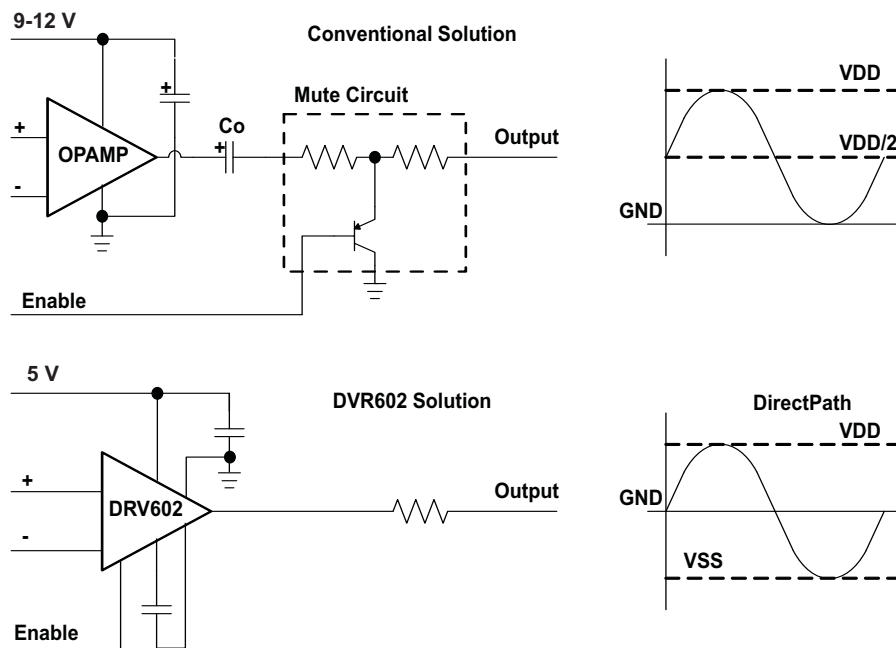

Figure 5. Conventional and DirectPath Line Driver

The DirectPath™ amplifier architecture operates from a single supply, but makes use of an internal charge pump to provide a negative voltage rail.

Combining the user provided positive rail and the negative rail generated by the IC, the device operates in what is effectively a split supply mode.

The output voltages are now centered at zero volts with the capability to swing to the positive rail or negative rail. The DirectPath amplifier requires no output dc blocking capacitors.

The bottom block diagram and waveform of [Figure 5](#) illustrate the ground-referenced Line Driver architecture. This is the architecture of the DRV602.

Charge Pump Flying Capacitor and PVSS Capacitor

The charge pump flying capacitor, C_{PUMP} , serves to transfer charge during the generation of the negative supply voltage. The PVSS capacitor must be at least equal to the charge pump capacitor in order to allow maximum charge transfer. Low ESR capacitors are an ideal selection, and a value of $1\mu\text{F}$ is typical. Capacitor values that are smaller than $1\mu\text{F}$ can be used, but the maximum output voltage may be reduced and the device may not operate to specifications.

Decoupling Capacitors

The DRV602 is a DirectPath Line Driver amplifier that require adequate power supply decoupling to ensure that the noise and total harmonic distortion (THD) are low. A good low equivalent-series-resistance (ESR) ceramic capacitor, typically $1\mu\text{F}$, placed as close as possible to the device PV_{DD} lead works best. Placing this decoupling capacitor close to the DRV602 is important for the performance of the amplifier. For filtering lower frequency noise signals, a $10\text{-}\mu\text{F}$ or greater capacitor placed near the audio power amplifier would also help, but it is not required in most applications because of the high PSRR of this device.

Gain setting resistors ranges

The gain setting resistors, R_{IN} and R_{fb} , must be chosen so that noise, stability and input capacitor size of the DRV602 is kept within acceptable limits. Voltage gain is defined as R_{fb} divided by R_{IN} .

Selecting values that are too low demands a large input ac-coupling capacitor, C_{IN} . Selecting values that are too high increases the noise of the amplifier. [Table 1](#) lists the recommended resistor values for different gain settings.

Table 1. Recommended Resistor Values

INPUT RESISTOR VALUE, R_{IN}	FEEDBACK RESISTOR VALUE, R_{fb}	DIFFERENTIAL INPUT GAIN	INVERTING INPUT GAIN	NON INVERTING INPUT GAIN
22 k Ω	22 k Ω	1.0 V/V	-1.0 V/V	2.0 V/V
15 k Ω	30 k Ω	1.5 V/V	-1.5 V/V	2.5 V/V
33 k Ω	68 k Ω	2.1 V/V	-2.1 V/V	3.1 V/V
10 k Ω	100 k Ω	10.0 V/V	-10.0 V/V	11.0 V/V

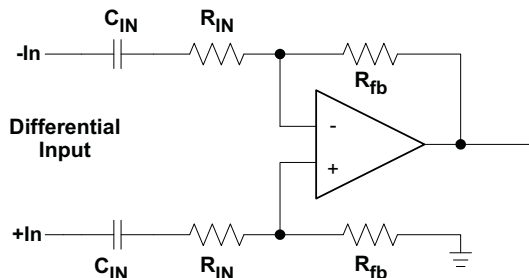

Figure 6. Differential Input

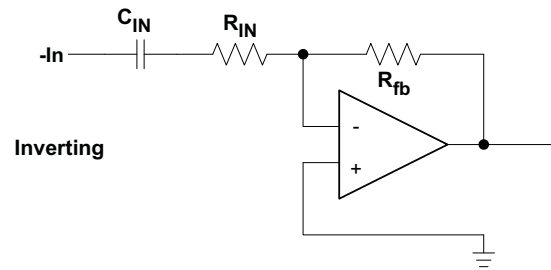

Figure 7. Inverting

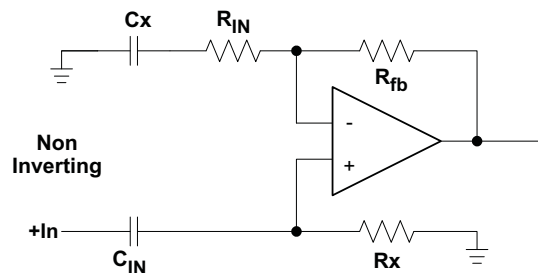

Figure 8. Non-Inverting

Input-Blocking Capacitors

DC input-blocking capacitors are required to be added in series with the audio signal into the input pins of the DRV602. These capacitors block the DC portion of the audio source and allow the DRV602 inputs to be properly biased to provide maximum performance. The input blocking capacitors also limit the DC gain to 1, limiting the DC-offset voltage at the output.

These capacitors form a high-pass filter with the input resistor, R_{IN} . The cutoff frequency is calculated using Equation 1. For this calculation, the capacitance used is the input-blocking capacitor and the resistance is the input resistor chosen from Table 1, then the frequency and/or capacitance can be determined when one of the two values are given.

$$f_{c_{IN}} = \frac{1}{2\pi R_{IN} C_{IN}} \quad \text{or} \quad C_{IN} = \frac{1}{2\pi f_{c_{IN}} R_{IN}} \quad (1)$$

Using the DRV602 as 2nd Order Filter

Several audio DACs used today require an external low-pass filter to remove out of band noise. This is possible with the DRV602 as it can be used like a standard OPAMP.

Several filter topologies can be implemented both single ended and differential. In Figure 9, a Multi FeedBack - MFB, with differential input and single ended input is shown.

An ac-coupling capacitor to remove dc-content from the source is shown, it serves to block any dc content from the source and lowers the dc-gain to 1 helping reducing the output dc-offset to minimum.

The component values can be calculated with the help of the TI FilterPro™ program available on the TI website at: <http://focus.ti.com/docs/toolsw/folders/print/filterpro.html>

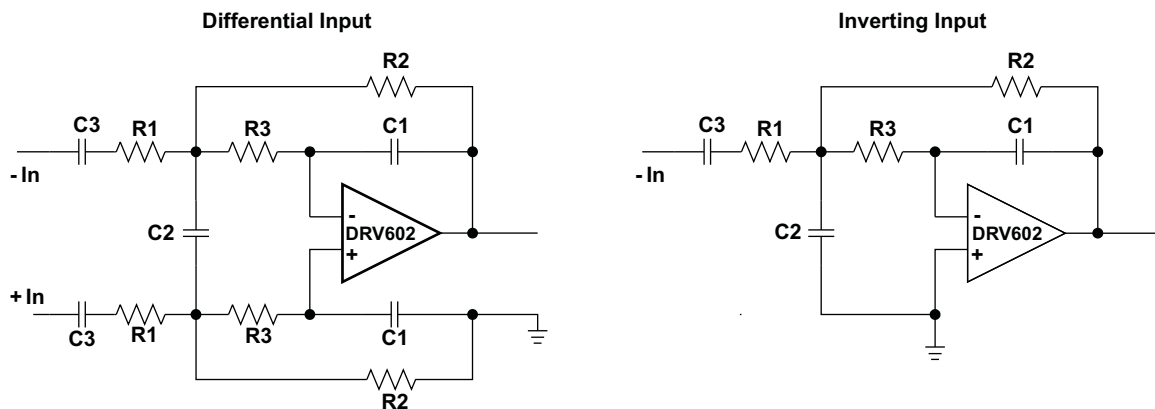

Figure 9. 2nd Order Active Low Pass Filter

The resistor values should have a low value for obtaining low noise, but should also have a high enough value to get a small size ac-coupling cap. With the proposed values, 33k, 68k, 100k, a DNR of 102dB can be achieved with a small 1 μ F input ac-coupling capacitor.

Pop-Free Power Up

Pop-free power up is ensured by keeping the EN (enable pin) low during power supply ramp up and down. The EN pin should be kept low until the input ac-coupling capacitors are fully charged before asserting the EN pin high; this way, proper precharge of the ac-coupling is performed, and pop-free power-up is achieved. [Figure 10](#) illustrates the preferred sequence.

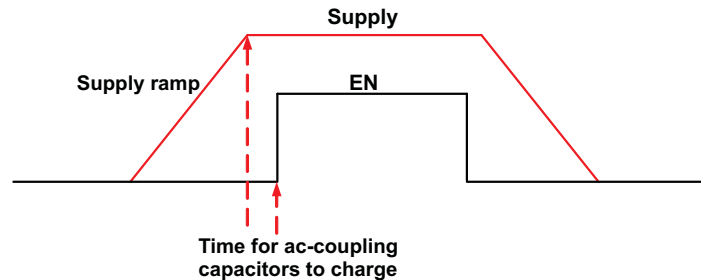

Figure 10. Power-Up Sequence

Capacitive Load

The DRV602 has the ability to drive a high capacitive load up to 220pF directly, higher capacitive loads can be accepted by adding a series resistor of 10Ω or larger.

Layout Recommendations

A proposed layout for the DRV602 can be seen in the DRV602EVM user's guide ([SLOU248](#)) and the Gerber files can be downloaded on www.ti.com, open the DRV602 product folder and look in the Tools and Software folder.

The gain setting resistors, R_{IN} and R_{fb} , must be placed close to the input pins to minimize the capacitive loading on these input pins and to ensure maximum stability of the DRV602. For the recommended PCB layout, see the DRV602EVM user's guide.

REVISION HISTORY

NOTE: Page numbers of current version may differ from previous versions.

Changes from Revision A (December 2008) to Revision B		Page
• Changed crosstalk spec from -80dB to -100dB		4
Changes from Revision B (October 2009) to Revision C		Page
• Added "Pop-Free" to title and changed "pop-less" to "pop-free in description text strings.		1
• Added Output Voltage Feature bullet: "3Vrms With 5-V Supply Voltage"		1
• Changed "2Vrms" to "3Vrms" in Description Section		1
• Changed "5V _{PP} " to "8.5V _{PP} " in Description Section		1
• Changed Recommended Operating Conditions T _A range from "0 to 70 °C" to "-40 to 85°C"		3
• Changed Electrical Characteristics Test Conditions V _{DD} from "4.5 V" to "5 V"		3
• Added "V _O " spec. for "V _{DD} = 5 V" to Operating Characteristics table		4
Changes from Revision May 2010 (C) to Revision D		Page
• Changed Abs Max Table (T _J) From: -40°C to 85°C to -40°C to 150		3
• Changed RIGHT INPUT From: + / - To: - / + in the Application Circuit		4
• Added R _L = 2.5 kΩ to the TYPICAL CHARACTERISTICS conditions statement		5
• Added , C _{PUMP} , to the first sentence of the Charge Pump Flying Capacitor and PVSS Capacitor section		7
• Changed V _{DD} To: PV _{DD} in Decoupling Capacitors section		7
• Changed SD (shutdown pin) to EN (enable pin) in the Pop-Free Power Up section		9
• Deleted last sentence in the Capacitive Load section		9

PACKAGING INFORMATION

Orderable Device	Status (1)	Package Type	Package Drawing	Pins	Package Qty	Eco Plan (2)	Lead/Ball Finish	MSL Peak Temp (3)	Op Temp (°C)	Top-Side Markings (4)	Samples
DRV602PW	ACTIVE	TSSOP	PW	14	90	Green (RoHS & no Sb/Br)	CU NIPDAU	Level-1-260C-UNLIM	-40 to 85	DRV602	Samples
DRV602PWR	ACTIVE	TSSOP	PW	14	2000	Green (RoHS & no Sb/Br)	CU NIPDAU	Level-1-260C-UNLIM	-40 to 85	DRV602	Samples

(1) The marketing status values are defined as follows:

ACTIVE: Product device recommended for new designs.

LIFEBUY: TI has announced that the device will be discontinued, and a lifetime-buy period is in effect.

NRND: Not recommended for new designs. Device is in production to support existing customers, but TI does not recommend using this part in a new design.

PREVIEW: Device has been announced but is not in production. Samples may or may not be available.

OBsolete: TI has discontinued the production of the device.

(2) Eco Plan - The planned eco-friendly classification: Pb-Free (RoHS), Pb-Free (RoHS Exempt), or Green (RoHS & no Sb/Br) - please check <http://www.ti.com/productcontent> for the latest availability information and additional product content details.

TBD: The Pb-Free/Green conversion plan has not been defined.

Pb-Free (RoHS): TI's terms "Lead-Free" or "Pb-Free" mean semiconductor products that are compatible with the current RoHS requirements for all 6 substances, including the requirement that lead not exceed 0.1% by weight in homogeneous materials. Where designed to be soldered at high temperatures, TI Pb-Free products are suitable for use in specified lead-free processes.

Pb-Free (RoHS Exempt): This component has a RoHS exemption for either 1) lead-based flip-chip solder bumps used between the die and package, or 2) lead-based die adhesive used between the die and leadframe. The component is otherwise considered Pb-Free (RoHS compatible) as defined above.

Green (RoHS & no Sb/Br): TI defines "Green" to mean Pb-Free (RoHS compatible), and free of Bromine (Br) and Antimony (Sb) based flame retardants (Br or Sb do not exceed 0.1% by weight in homogeneous material)

(3) MSL, Peak Temp. -- The Moisture Sensitivity Level rating according to the JEDEC industry standard classifications, and peak solder temperature.

(4) Multiple Top-Side Markings will be inside parentheses. Only one Top-Side Marking contained in parentheses and separated by a "~" will appear on a device. If a line is indented then it is a continuation of the previous line and the two combined represent the entire Top-Side Marking for that device.

Important Information and Disclaimer: The information provided on this page represents TI's knowledge and belief as of the date that it is provided. TI bases its knowledge and belief on information provided by third parties, and makes no representation or warranty as to the accuracy of such information. Efforts are underway to better integrate information from third parties. TI has taken and continues to take reasonable steps to provide representative and accurate information but may not have conducted destructive testing or chemical analysis on incoming materials and chemicals. TI and TI suppliers consider certain information to be proprietary, and thus CAS numbers and other limited information may not be available for release.

In no event shall TI's liability arising out of such information exceed the total purchase price of the TI part(s) at issue in this document sold by TI to Customer on an annual basis.

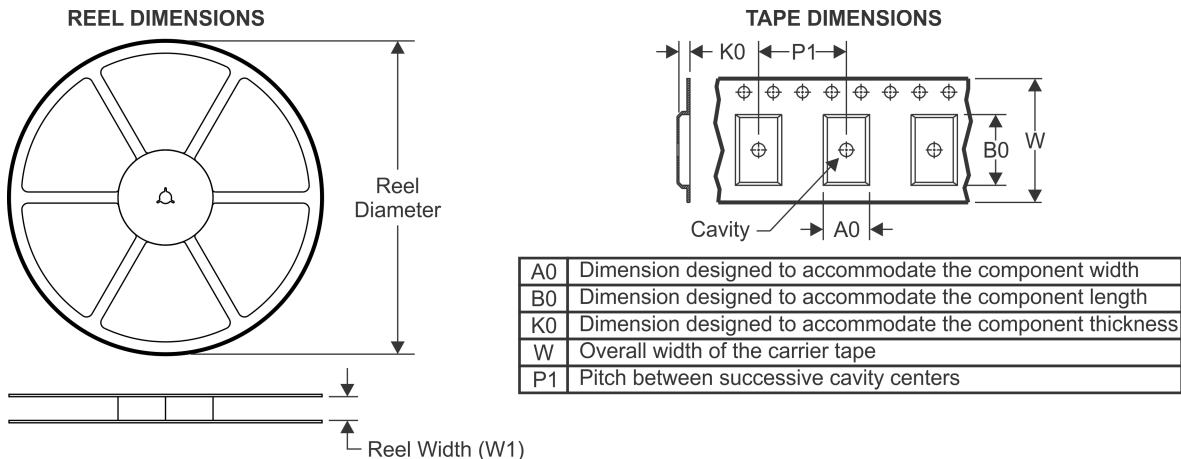
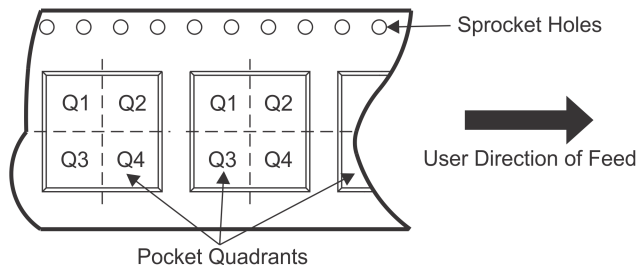
TAPE AND REEL INFORMATION

QUADRANT ASSIGNMENTS FOR PIN 1 ORIENTATION IN TAPE

*All dimensions are nominal

Device	Package Type	Package Drawing	Pins	SPQ	Reel Diameter (mm)	Reel Width W1 (mm)	A0 (mm)	B0 (mm)	K0 (mm)	P1 (mm)	W (mm)	Pin1 Quadrant
DRV602PWR	TSSOP	PW	14	2000	330.0	12.4	6.95	5.6	1.6	8.0	12.0	Q1
DRV602PWR	TSSOP	PW	14	2000	330.0	12.4	6.9	5.6	1.6	8.0	12.0	Q1

TAPE AND REEL BOX DIMENSIONS

*All dimensions are nominal

Device	Package Type	Package Drawing	Pins	SPQ	Length (mm)	Width (mm)	Height (mm)
DRV602PWR	TSSOP	PW	14	2000	355.0	350.0	50.0
DRV602PWR	TSSOP	PW	14	2000	367.0	367.0	35.0

PW (R-PDSO-G14)

PLASTIC SMALL OUTLINE

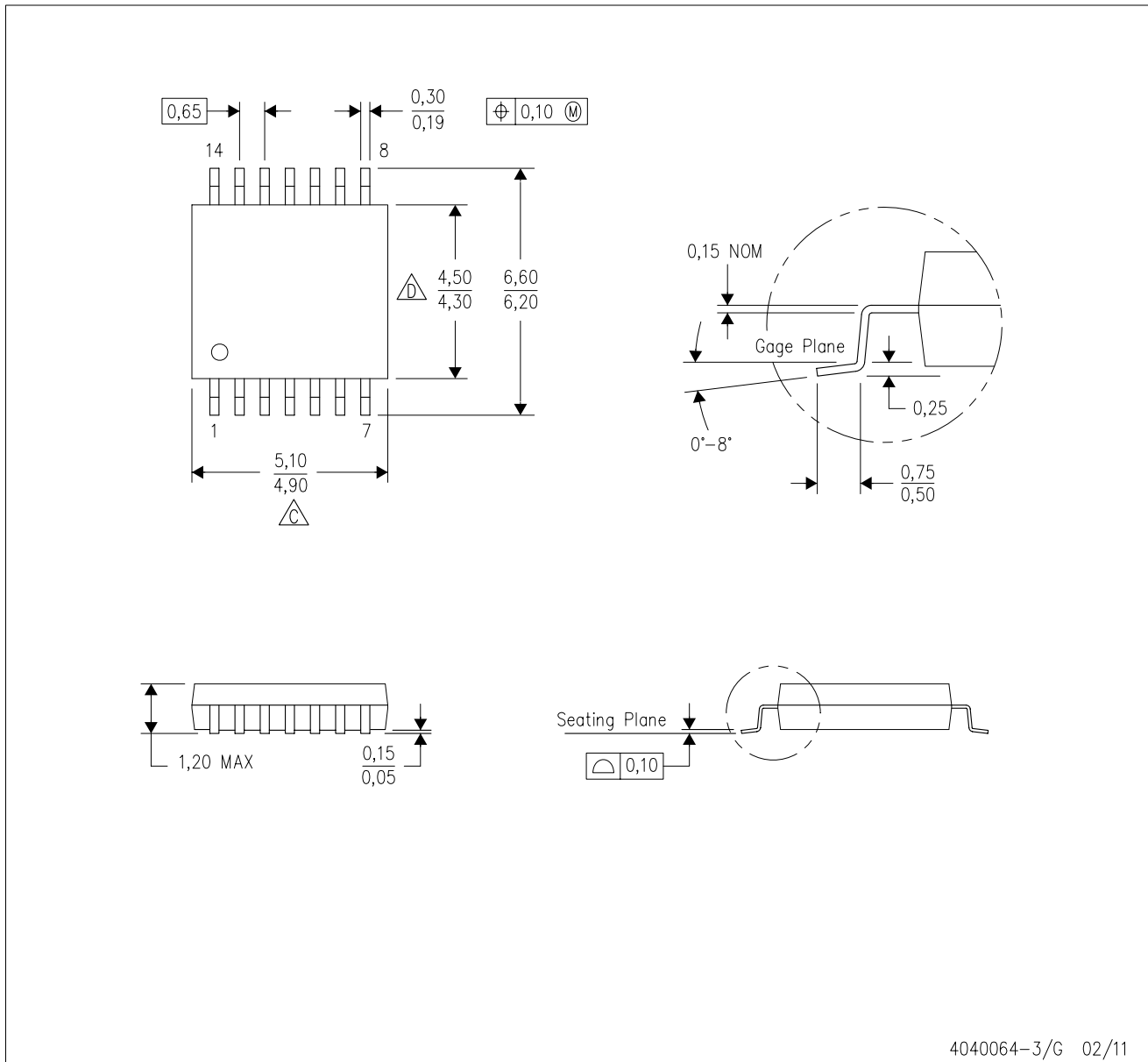

- NOTES:
- A. All linear dimensions are in millimeters. Dimensioning and tolerancing per ASME Y14.5M-1994.
 - B. This drawing is subject to change without notice.
 - C. Body length does not include mold flash, protrusions, or gate burrs. Mold flash, protrusions, or gate burrs shall not exceed 0,15 each side.
 - D. Body width does not include interlead flash. Interlead flash shall not exceed 0,25 each side.
 - E. Falls within JEDEC MO-153

PW (R-PDSO-G14)

PLASTIC SMALL OUTLINE



- NOTES:
- All linear dimensions are in millimeters.
 - This drawing is subject to change without notice.
 - Publication IPC-7351 is recommended for alternate designs.
 - Laser cutting apertures with trapezoidal walls and also rounding corners will offer better paste release. Customers should contact their board assembly site for stencil design recommendations. Refer to IPC-7525 for other stencil recommendations.
 - Customers should contact their board fabrication site for solder mask tolerances between and around signal pads.

IMPORTANT NOTICE

Texas Instruments Incorporated and its subsidiaries (TI) reserve the right to make corrections, enhancements, improvements and other changes to its semiconductor products and services per JESD46, latest issue, and to discontinue any product or service per JESD48, latest issue. Buyers should obtain the latest relevant information before placing orders and should verify that such information is current and complete. All semiconductor products (also referred to herein as "components") are sold subject to TI's terms and conditions of sale supplied at the time of order acknowledgment.

TI warrants performance of its components to the specifications applicable at the time of sale, in accordance with the warranty in TI's terms and conditions of sale of semiconductor products. Testing and other quality control techniques are used to the extent TI deems necessary to support this warranty. Except where mandated by applicable law, testing of all parameters of each component is not necessarily performed.

TI assumes no liability for applications assistance or the design of Buyers' products. Buyers are responsible for their products and applications using TI components. To minimize the risks associated with Buyers' products and applications, Buyers should provide adequate design and operating safeguards.

TI does not warrant or represent that any license, either express or implied, is granted under any patent right, copyright, mask work right, or other intellectual property right relating to any combination, machine, or process in which TI components or services are used. Information published by TI regarding third-party products or services does not constitute a license to use such products or services or a warranty or endorsement thereof. Use of such information may require a license from a third party under the patents or other intellectual property of the third party, or a license from TI under the patents or other intellectual property of TI.

Reproduction of significant portions of TI information in TI data books or data sheets is permissible only if reproduction is without alteration and is accompanied by all associated warranties, conditions, limitations, and notices. TI is not responsible or liable for such altered documentation. Information of third parties may be subject to additional restrictions.

Resale of TI components or services with statements different from or beyond the parameters stated by TI for that component or service voids all express and any implied warranties for the associated TI component or service and is an unfair and deceptive business practice. TI is not responsible or liable for any such statements.

Buyer acknowledges and agrees that it is solely responsible for compliance with all legal, regulatory and safety-related requirements concerning its products, and any use of TI components in its applications, notwithstanding any applications-related information or support that may be provided by TI. Buyer represents and agrees that it has all the necessary expertise to create and implement safeguards which anticipate dangerous consequences of failures, monitor failures and their consequences, lessen the likelihood of failures that might cause harm and take appropriate remedial actions. Buyer will fully indemnify TI and its representatives against any damages arising out of the use of any TI components in safety-critical applications.

In some cases, TI components may be promoted specifically to facilitate safety-related applications. With such components, TI's goal is to help enable customers to design and create their own end-product solutions that meet applicable functional safety standards and requirements. Nonetheless, such components are subject to these terms.

No TI components are authorized for use in FDA Class III (or similar life-critical medical equipment) unless authorized officers of the parties have executed a special agreement specifically governing such use.

Only those TI components which TI has specifically designated as military grade or "enhanced plastic" are designed and intended for use in military/aerospace applications or environments. Buyer acknowledges and agrees that any military or aerospace use of TI components which have **not** been so designated is solely at the Buyer's risk, and that Buyer is solely responsible for compliance with all legal and regulatory requirements in connection with such use.

TI has specifically designated certain components as meeting ISO/TS16949 requirements, mainly for automotive use. In any case of use of non-designated products, TI will not be responsible for any failure to meet ISO/TS16949.

Products

Audio	www.ti.com/audio
Amplifiers	amplifier.ti.com
Data Converters	dataconverter.ti.com
DLP® Products	www.dlp.com
DSP	dsp.ti.com
Clocks and Timers	www.ti.com/clocks
Interface	interface.ti.com
Logic	logic.ti.com
Power Mgmt	power.ti.com
Microcontrollers	microcontroller.ti.com
RFID	www.ti-rfid.com
OMAP Applications Processors	www.ti.com/omap
Wireless Connectivity	www.ti.com/wirelessconnectivity

Applications

Automotive and Transportation	www.ti.com/automotive
Communications and Telecom	www.ti.com/communications
Computers and Peripherals	www.ti.com/computers
Consumer Electronics	www.ti.com/consumer-apps
Energy and Lighting	www.ti.com/energy
Industrial	www.ti.com/industrial
Medical	www.ti.com/medical
Security	www.ti.com/security
Space, Avionics and Defense	www.ti.com/space-avionics-defense
Video and Imaging	www.ti.com/video

TI E2E Community

e2e.ti.com