

DS92LV0421 / DS92LV0422 10 - 75 MHz Channel Link II Serializer/Deserializer with LVDS Parallel Interface

Check for Samples: [DS92LV0421](#), [DS92LV0422](#)

FEATURES

- **General**
 - **5-Channel (4 Data + 1 Clock) Channel Link LVDS Parallel Interface Supports 24-bit Data 3-bit Control at 10 – 75 MHz**
 - **AC Coupled STP Interconnect up to 10 Meters in Length**
 - **Integrated Serial CML Terminations**
 - **AT–SPEED BIST Mode and Status Pin**
 - **Optional I2C Compatible Serial Control Bus**
 - **Power Down Mode Minimizes Power Dissipation**
 - **1.8V or 3.3V Compatible Control Pin Interface**
 - **>8 kV ESD (HBM) Protection**
 - **-40° to +85°C Temperature Range**
- **SERIALIZER – DS92LV0421**
 - **Data Scrambler for Reduced EMI**
 - **DC–Balance Encoder for AC Coupling**
 - **Selectable Output VOD and Adjustable De-emphasis**
- **DESERIALIZER – DS92LV0422**
 - **Random Data Lock; no Reference Clock Required**
 - **Adjustable Input Receiver Equalization**
 - **EMI Minimization on Output Parallel Bus (Spread Spectrum Clock Generation and LVDS VOD Select)**

APPLICATIONS

- **Embedded Video and Display**
- **Machine Vision, Industrial Imaging, Medical Imaging**
- **Office Automation — Printers, Scanners, Copiers**
- **Security and Video Surveillance**
- **General Purpose Data Communication**

DESCRIPTION

The DS92LV0421 (serializer) and DS92LV0422 (deserializer) chipset translates a Channel Link LVDS video interface (4 LVDS Data + LVDS Clock) into a high-speed serialized interface over a single CML pair.

The DS92LV0421 and DS92LV0422 enable applications that currently use the popular Channel Link or Channel Link style devices to seamlessly upgrade to an embedded clock interface to reduce interconnect cost or ease design challenges. The parallel LVDS interface also reduces FPGA I/O pins, board trace count and alleviates EMI issues, when compared to traditional single-ended wide bus interfaces.

Programmable transmit de-emphasis, receive equalization, on-chip scrambling and DC balancing enables longer distance transmission over lossy cables and backplanes. The Deserializer automatically locks to incoming data without an external reference clock or special sync patterns, providing easy “plug-and-go” operation.

The DS92LV0421 and DS92LV0422 are programmable through an I2C interface as well as by pins. A built-in AT-SPEED BIST feature validates link integrity and may be used for system diagnostics.

The DS92LV0421 and DS92LV0422 can be used interchangeably with the DS92LV2421 or DS92LV2422. This allows designers the flexibility to connect to the host device and receiving devices with different interface types, LVDS or LVCMOS.



Please be aware that an important notice concerning availability, standard warranty, and use in critical applications of Texas Instruments semiconductor products and disclaimers thereto appears at the end of this data sheet.

All trademarks are the property of their respective owners.

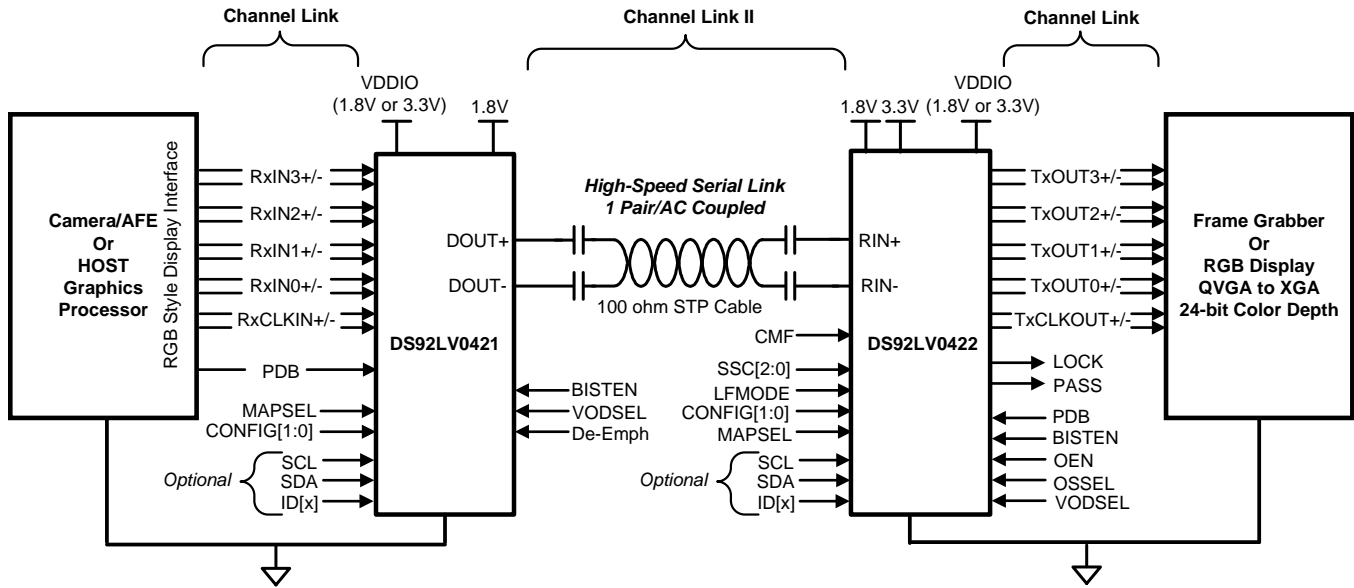
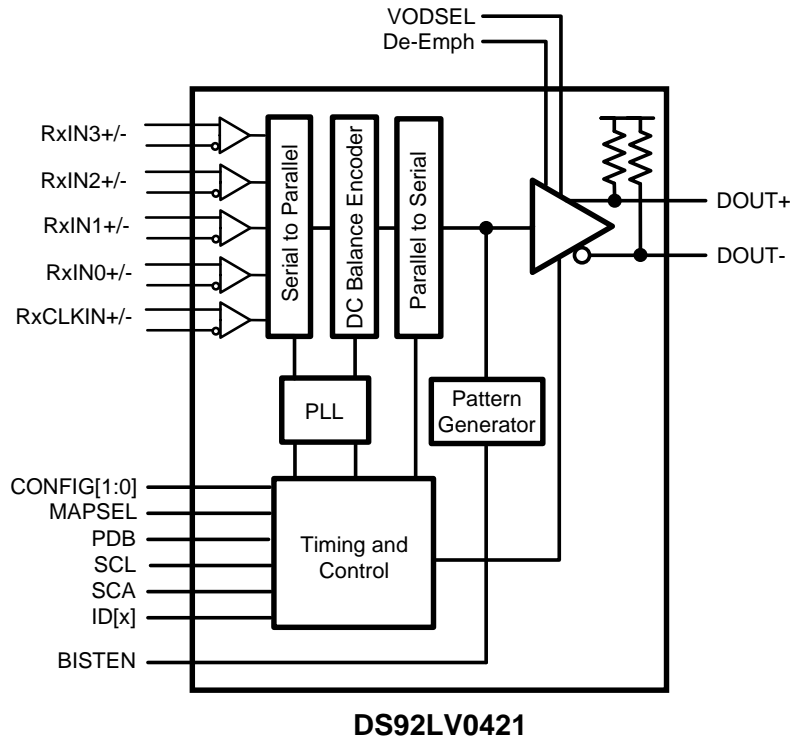
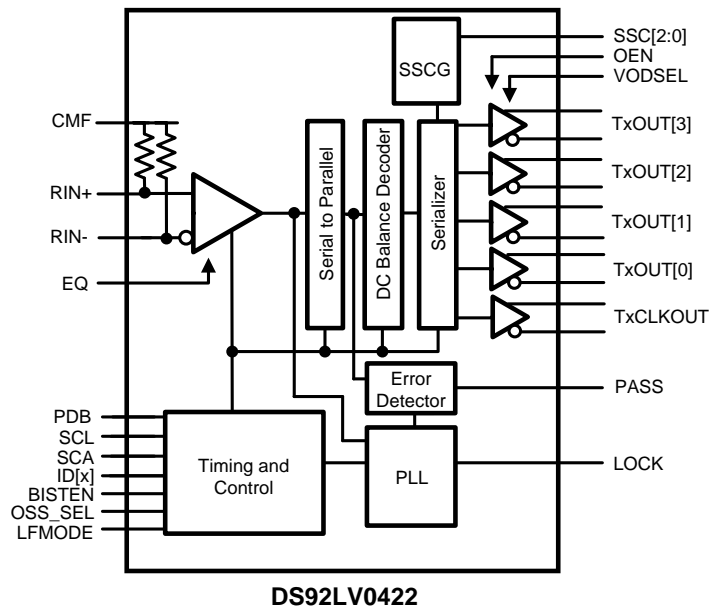

Figure 1. Application Diagram

Block Diagrams





DS92LV0421 Pin Diagram

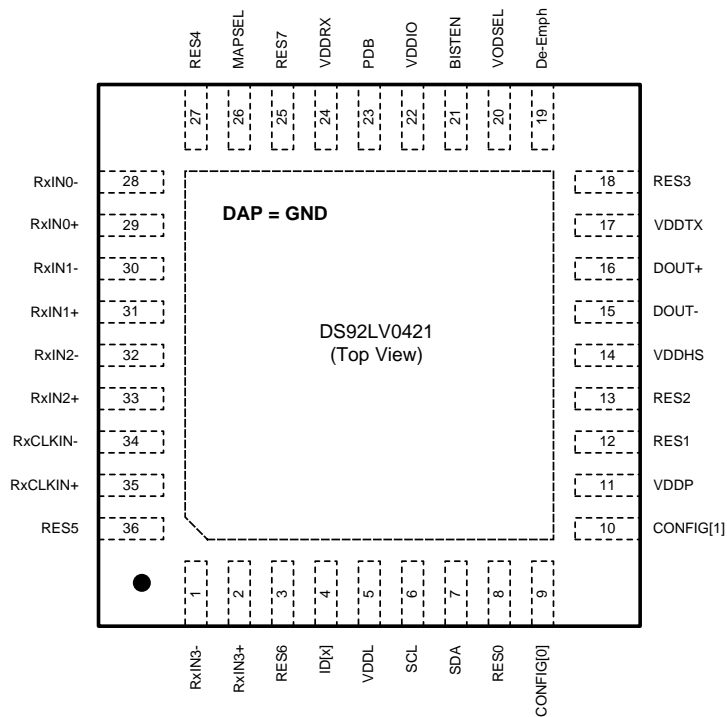

Figure 2. DS92LV0421 36-Pin WQFN Package
See Package Number NJK0036A

DS92LV0421 PIN DESCRIPTIONS

Pin Name	Pin No.	I/O, Type	Description
Channel Link Parallel Input Interface			
RxIN[3:0]+	2, 33, 31, 29	I, LVDS	True LVDS Data Input This pair should have a 100 Ω termination for standard LVDS levels.
RxIN[3:0]-	1, 34, 32, 30, 28	I, LVDS	Inverting LVDS Data Input This pair should have a 100 Ω termination for standard LVDS levels.
RxCLKIN+	35	I, LVDS	True LVDS Clock Input This pair should have a 100 Ω termination for standard LVDS levels.
RxCLKIN-	34	I, LVDS	Inverting LVDS Clock Input This pair should have a 100 Ω termination for standard LVDS levels.
Control and Configuration			
PDB	23	I, LVCMOS w/ pull-down	Power-down Mode Input PDB = 1, Device is enabled (normal operation). Refer to Power Up Requirements and PDB Pin PDB = 0, Device is powered down When the Device is in the power-down state, the driver outputs (DOUT+/-) are both logic high, the PLL is shutdown, IDD is minimized. Control Registers are RESET .
VODSEL	20	I, LVCMOS w/ pull-down	Differential Driver Output Voltage Select — Pin or Register Control VODSEL = 1, LVDS VOD is ± 450 mV, 900 mVp-p (typ) — Long Cable / De-E Applications VODSEL = 0, LVDS VOD is ± 300 mV, 600 mVp-p (typ)
De-Emph	19	I, Analog w/ pull-up	De-Emphasis Control — Pin or Register Control De-Emph = open (float) - disabled To enable De-emphasis, tie a resistor from this pin to GND or control via register. See Table 4
MAPSEL	26	I, LVCMOS w/ pull-down	Channel Link Map Select — Pin or Register Control MAPSEL = 1, MSB on RxIN3+/- . See Figure 24 MAPSEL = 0, LSB on RxIN3+/- . See Figure 23
CONFIG[1:0]	10, 9	I, LVCMOS w/ pull-down	Operating Modes — Pin or Limited Register Control Determines the device operating mode and interfacing device. See Table 1 CONFIG[1:0] = 00: Interfacing to DS92LV2422 or DS92LV0422, Control Signal Filter DISABLED CONFIG[1:0] = 01: Interfacing to DS92LV2422 or DS92LV0422, Control Signal Filter ENABLED CONFIG [1:0] = 10: Interfacing to DS90UR124, DS99R124 CONFIG [1:0] = 11: Interfacing to DS90C124
ID[x]	4	I, Analog	Serial Control Bus Device ID Address Select — Optional Resistor to Ground and 10 k Ω pull-up to 1.8V rail. See Table 10
SCL	6	I, LVCMOS	Serial Control Bus Clock Input - Optional SCL requires an external pull-up resistor to V_{DDIO} .
SDA	7	I/O, LVCMOS Open Drain	Serial Control Bus Data Input / Output - Optional SDA requires an external pull-up resistor V_{DDIO} .
BISTEN	21	I, LVCMOS w/ pull-down	BIST Mode — Optional BISTEN = 1, BIST is enabled BISTEN = 0, BIST is disabled
RES[7:0]	25, 3, 36, 27, 18, 13, 12, 8	I, LVCMOS w/ pull-down	Reserved - tie LOW
Channel Link II Serial Interface			
DOUT+	16	O, CML	True Output. The output must be AC Coupled with a 0.1 μ F capacitor.
DOUT-	15	O, CML	Inverting Output. The output must be AC Coupled with a 0.1 μ F capacitor.

DS92LV0421 PIN DESCRIPTIONS (continued)

Pin Name	Pin No.	I/O, Type	Description
Power and Ground⁽¹⁾			
VDDL	5	Power	Logic Power, 1.8 V \pm 5%
VDDP	11	Power	PLL Power, 1.8 V \pm 5%
VDDHS	14	Power	TX High Speed Logic Power, 1.8 V \pm 5%
VDDTX	17	Power	Output Driver Power, 1.8 V \pm5%
VDDR _X	24	Power	RX Power, 1.8 V \pm 5%
VDDIO	22	Power	LVC MOS I/O Power and Channel Link I/O Power 1.8 V \pm5% OR 3.3 V \pm10%
GND	DAP	Ground	DAP is the large metal contact at the bottom side, located at the center of the WQFN package. Connect to the ground plane (GND) with at least 9 vias.

(1) 1= HIGH, 0 L= LOW. The VDD (V_{DDn} and V_{DDIO}) supply ramp should be faster than 1.5 ms with a monotonic rise. If slower than 1.5 ms then a capacitor on the PDB pin is needed to ensure PDB arrives after all the VDD have settled to the recommended operating voltage.

DS92LV0422 Pin Diagram

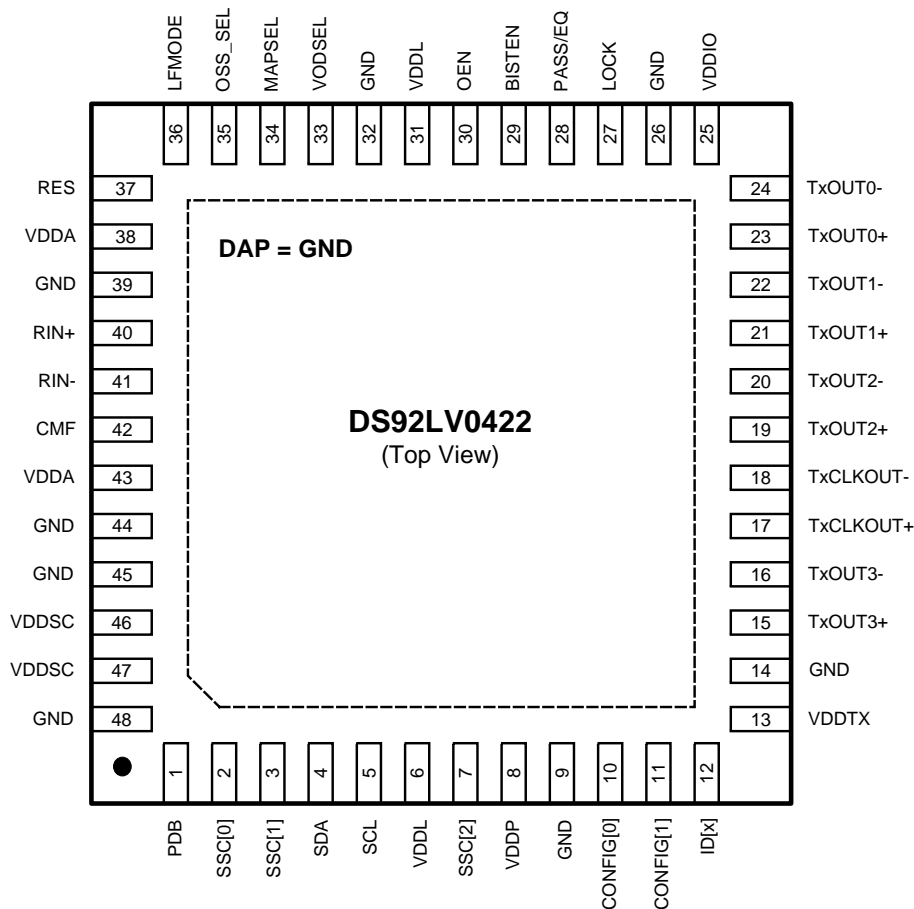

Figure 3. DS92LV0422 48-Pin WQFN Package
See Package Number RHS0048A

DS92LV0422 PIN DESCRIPTIONS

Pin Name	Pin No.	I/O, Type	Description
Channel Link II Serial Interface			
RIN++	40	I, CML	True Input. The output must be AC Coupled with a 0.1 μ F capacitor.
RIN-	41	I, CML	Inverting Input. The output must be AC Coupled with a 0.1 μ F capacitor.
Channel Link Parallel Output Interface			
RxIN[3:0]+	15, 19, 21, 23	O, LVDS	True LVDS Data Output This pair should have a 100 Ω termination for standard LVDS levels.
RxIN[3:0]-	16, 20, 22, 24	O, LVDS	Inverting LVDS Data Output This pair should have a 100 Ω termination for standard LVDS levels.
RxCLKIN+	17	O, LVDS	True LVDS Clock Output This pair should have a 100 Ω termination for standard LVDS levels.
RxCLKIN-	18	O, LVDS	Inverting LVDS Clock Output This pair should have a 100 Ω termination for standard LVDS levels.
LVC MOS Outputs			
LOCK	27	O, LVC MOS	LOCK Status Output LOCK = 1, PLL is locked, output stated determined by OEN. LOCK = 0, PLL is unlocked, output states determined by OSS_SEL and OEN. See Table 5 .
Control and Configuration			
PDB	1	I, LVC MOS w/ pull-down	Power-down Mode Input PDB = 1, Device is enabled (normal operation). Refer to Power Up Requirements and PDB Pin PDB = 0, Device is powered down When the Device is in the power-down state, the driver outputs (DOUT+/-) are both logic high, the PLL is shutdown, IDD is minimized. Control Registers are RESET .
VODSEL	33	I, LVC MOS w/ pull-down	Parallel LVDS Driver Output Voltage Select — Pin or Register Control VODSEL = 1, LVDS VOD is ± 400 mV, 800 mVp-p (typ) VODSEL = 0, LVDS VOD is ± 250 mV, 500 mVp-p (typ)
OEN	30	I, LVC MOS w/ pull-down	Output Enable. See Table 5 .
OSS_SEL	35	I, LVC MOS w/ pull-down	Output Sleep State Select Input. See Table 5 .
LFMODE	36	I, LVC MOS w/ pull-down	SSCG Low Frequency Mode — Pin or Register Control LF_MODE = 1, low frequency mode (TxCLKOUT = 10–20 MHz) LF_MODE = 0, high frequency mode (TxCLKOUT = 20–65 MHz) SSCG not available above 65 MHz.
MAPSEL	34	I, LVC MOS w/ pull-down	Channel Link Map Select — Pin or Register Control MAPSEL = 1, MSB on TxOUT3+/- . See Figure 24 MAPSEL = 0, LSB on TxOUT3+/- . See Figure 23
CONFIG[1:0]	11, 10	I, LVC MOS w/ pull-down	Operating Modes — Pin or Limited Register Control Determine the device operating mode and interfacing device. See Table 1 CONFIG[1:0] = 00: Interfacing to DS92LV2421 or DS92LV0421, Control Signal Filter DISABLED CONFIG[1:0] = 01: Interfacing to DS92LV2421 or DS92LV0421, Control Signal Filter ENABLED CONFIG [1:0] = 10: Interfacing to DS90UR241, DS99R421 CONFIG [1:0] = 11: Interfacing to DS90C124
SSC[2:0]	7, 3, 2	I, LVC MOS w/ pull-down	Spread Spectrum Clock Generation (SSCG) Range Select See Table 8 and Table 9
RES	37	I, LVC MOS w/ pull-down	Reserved
Control and Configuration — STRAP PIN			
EQ	28 [PASS]	STRAP I, LVC MOS w/ pull-down	EQ Gain Control of Channel Link II Serial Input EQ = 1, EQ gain is enabled (~13 dB) EQ = 0, EQ gain is disabled (~1.625 dB)

DS92LV0422 PIN DESCRIPTIONS (continued)

Pin Name	Pin No.	I/O, Type	Description
Optional BIST Mode			
BISTEN	29	I, LVCMOS w/ pull-down	BIST Mode — Optional BISTEN = 1, BIST is enabled BISTEN = 0, BIST is disabled
PASS	28	O, LVCMOS	PASS Output (BIST Mode) — Optional PASS = 1, no errors detected PASS = 0, errors detected Leave open if unused. Route to a test point (pad) recommended.
Optional Serial Bus Control			
ID[x]	12	I, Analog	Serial Control Bus Device ID Address Select — Optional Resistor to Ground and 10 kΩ pull-up to 1.8V rail. See Table 10 .
SCL	5	I, LVCMOS Open Drain	Serial Control Bus Clock Input - Optional SCL requires an external pull-up resistor to 3.3V.
SDA	4	I/O, LVCMOS Open Drain	Serial Control Bus Data Input / Output - Optional SDA requires an external pull-up resistor 3.3V.
Power and Ground⁽¹⁾			
VDDL	6, 31	Power	Logic Power, 1.8 V ±5%
VDDA	38, 43	Power	Analog Power, 1.8 V ±5%
VDDP	8	Power	PLL Power, 1.8 V ±5%
VDDSC	46, 47	Power	SSC Generator Power, 1.8 V ±5%
VDDTX	13	Power	Channel Link LVDS Parallel Output Power, 3.3 V ±10%
VDDIO	25	Power	LVCMOS I/O Power and Channel Link I/O Power 1.8 V ±5% OR 3.3 V ±10%
GND	9, 14, 26, 32, 39, 44, 45, 48	Ground	Ground
DAP	DAP	Ground	DAP is the large metal contact at the bottom side, located at the center of the WQFN package. Connect to the ground plane (GND) with at least 9 vias.

(1) 1= HIGH, 0 L= LOW. The VDD (V_{DDn} and V_{DDIO}) supply ramp should be faster than 1.5 ms with a monotonic rise. If slower than 1.5 ms then a capacitor on the PDB pin is needed to ensure PDB arrives after all the VDD have settled to the recommended operating voltage.



These devices have limited built-in ESD protection. The leads should be shorted together or the device placed in conductive foam during storage or handling to prevent electrostatic damage to the MOS gates.

Absolute Maximum Ratings⁽¹⁾⁽²⁾

Supply Voltage – V_{DDn} (1.8V)	-0.3V to +2.5V
Supply Voltage – V_{DDIO}	-0.3V to +4.0V
Supply Voltage – V_{DDTX} (1.8V, Ser)	-0.3V to +2.5V
Supply Voltage – V_{DDTX} (3.3V, Des)	-0.3V to +4.0V
LVCMOS I/O Voltage	-0.3V to ($V_{DDIO} + 0.3V$)
LVDS Input Voltage	-0.3V to ($V_{DDIO} + 0.3V$)
LVDS Output Voltage	-0.3V to ($V_{DDTX} + 0.3V$)
CML Driver Output Voltage	-0.3V to ($V_{DDn} + 0.3V$)
Receiver Input Voltage	-0.3V to ($V_{DD} + 0.3V$)
Junction Temperature	+150°C
Storage Temperature	-65°C to +150°C
36L WQFN Package	
Maximum Power Dissipation Capacity at 25°C	
Derate above 25°C	1/ θ_{JA} °C/W
θ_{JA} (with 9 thermal via)	27.4 °C/W
θ_{JC} (with 9 thermal via)	4.5 °C/W
48L WQFN Package	
Maximum Power Dissipation Capacity at 25°C	
Derate above 25°C	1/ θ_{JA} °C/W
θ_{JA} (with 9 thermal via)	27.7 °C/W
θ_{JC} (with 9 thermal via)	3.0 °C/W
ESD Rating (IEC, powered-up only), $R_D = 330\Omega$, $C_S = 150$ pF	
Air Discharge (R_{IN+} , R_{IN-})	$\geq \pm 30$ kV
Contact Discharge (R_{IN+} , R_{IN-})	$\geq \pm 8$ kV
ESD Rating (HBM)	$\geq \pm 8$ kV
ESD Rating (CDM)	$\geq \pm 1.25$ kV
ESD Rating (MM)	$\geq \pm 250$ V
For soldering specifications see SNOA549 .	

- (1) "Absolute Maximum Ratings" indicate limits beyond which damage to the device may occur, including inoperability and degradation of device reliability and/or performance. Functional operation of the device and/or non-degradation at the Absolute Maximum Ratings or other conditions beyond those indicated in the Recommended Operating Conditions is not implied. The Recommended Operating Conditions indicate conditions at which the device is functional and the device should not be operated beyond such conditions.
- (2) If Military/Aerospace specified devices are required, please contact the Texas Instruments Sales Office/ Distributors for availability and specifications.

Recommended Operating Conditions

	Min	Nom	Max	Units
Supply Voltage (V_{DDn})	1.71	1.8	1.89	V
Supply Voltage (V_{DDTX_Ser})	1.71	1.8	1.89	V
Supply Voltage (V_{DDTX_Des})	3.0	3.3	3.6	V
LVCMOS Supply Voltage (V_{DDIO})	1.71	1.8	1.89	V
OR				
LVCMOS Supply Voltage (V_{DDIO})	3.0	3.3	3.6	V
Operating Free Air Temperature (T_A)	-40	+25	+85	°C
RxCLKIN/TxCLKOUT Clock Frequency	10		75	MHz
Supply Noise ⁽¹⁾			100	mV _{P-P}

- (1) Supply noise testing was done with minimum capacitors on the PCB. A sinusoidal signal is AC coupled to the V_{DDn} (1.8V) supply with amplitude = 100 mVp-p measured at the device V_{DDn} pins. Bit error rate testing of input to the Ser and output of the Des with 10 meter cable shows no error when the noise frequency on the Ser is less than 750 kHz. The Des on the other hand shows no error when the noise frequency is less than 400 kHz.

DC Electrical Characteristics ⁽¹⁾⁽²⁾⁽³⁾⁽⁴⁾⁽⁵⁾⁽⁶⁾

Over recommended operating supply and temperature ranges unless otherwise specified.

Parameter	Test Conditions	Pin/Freq.	Min	Typ	Max	Units	
DS92LV0421 LVCMOS INPUT DC SPECIFICATIONS							
V _{IH}	High Level Input Voltage		V _{DDIO} = 3.0 to 3.6V	2.0		V _{DDIO}	V
			V _{DDIO} = 1.71 to 1.89V	0.65* V _{DDIO}		V _{DDIO}	V
V _{IL}	Low Level Input Voltage		V _{DDIO} = 3.0 to 3.6V	GND		0.8	V
			V _{DDIO} = 1.71 to 1.89V	GND		0.35* V _{DDIO}	V
I _{IN}	Input Current	V _{IN} = 0V or V _{DDIO}	V _{DDIO} = 3.0 to 3.6V	-15	±1	+15	µA
			V _{DDIO} = 1.7 to 1.89V	-15	±1	+15	µA
DS92LV0422 LVCMOS I/O DC SPECIFICATIONS							
V _{IH}	High Level Input Voltage		V _{DDIO} = 3.0 to 3.6V	2.0		V _{DDIO}	V
			V _{DDIO} = 1.71 to 1.89V	0.65* V _{DDIO}		V _{DDIO}	V
V _{IL}	Low Level Input Voltage		V _{DDIO} = 3.0 to 3.6V	GND		0.8	V
			V _{DDIO} = 1.71 to 1.89V	GND		0.35* V _{DDIO}	V
I _{IN}	Input Current	V _{IN} = 0V or V _{DDIO}	V _{DDIO} = 3.0 to 3.6V	-15	±1	+15	µA
			V _{DDIO} = 1.7 to 1.89V	-15	±1	+15	µA
V _{OH}	High Level Output Voltage	I _{OH} = -0.5 mA	V _{DDIO} - 0.2	V _{DDIO}		V	
V _{OL}	Low Level Output Voltage	I _{OL} = +0.5 mA		GND	0.2	V	
I _{OS}	Output Short Circuit Current	V _{OUT} = 0V	V _{DDIO} = 3.0 to 3.6 V		-10		mA
			V _{DDIO} = 1.71 to 1.89V		-3		
I _{OZ}	TRI-STATE Output Current	PDB = 0V, OSS_SEL = 0V, V _{OUT} = 0V or V _{DDIO}	V _{DDIO} = 3.0 to 3.6 V	-10		+10	µA
			V _{DDIO} = 1.71 to 1.89V	-15		+15	

- (1) Specification is verified by characterization and is not tested in production.
- (2) Specification is verified by design and is not tested in production.
- (3) The Electrical Characteristics tables list verified specifications under the listed Recommended Operating Conditions except as otherwise modified or specified by the Electrical Characteristics Conditions and/or Notes. Typical specifications are estimations only and are not verified.
- (4) Typical values represent most likely parametric norms at V_{DD} = 3.3V, T_a = +25°C, and at the Recommended Operation Conditions at the time of product characterization and are not verified.
- (5) Current into device pins is defined as positive. Current out of a device pin is defined as negative. Voltages are referenced to ground except V_{OD}, ΔV_{OD}, V_{TH} and V_{TL} which are differential voltages.
- (6) When the device output is at TRI-STATE the Deserializer will lose PLL lock. Resynchronization / Relock must occur before data transfer require t_{PLD}

DC Electrical Characteristics⁽¹⁾⁽²⁾⁽³⁾⁽⁴⁾⁽⁵⁾⁽⁶⁾ (continued)

Over recommended operating supply and temperature ranges unless otherwise specified.

Parameter		Test Conditions		Pin/Freq.	Min	Typ	Max	Units	
DS92LV0421 CHANNEL LINK PARALLEL LVDS RECEIVER DC SPECIFICATIONS									
V _{TH}	Differential Threshold High Voltage	V _{CM} = 1.2V, See Figure 4		RxIN[3:0]+/-, RxCLKIN+/-,			+100	mV	
V _{TL}	Differential Threshold Low Voltage				-100				
V _{ID}	Differential Input Voltage Swing				200		600	mV	
V _{CM}	Common Mode Voltage	V _{DDIO} = 3.3V			0	1.2	2.4	V	
		V _{DDIO} = 1.8V			0	1.2	1.7		
I _{IN}	Input Current				-10	±1	+10	µA	
DS92LV0422 CHANNEL LINK PARALLEL LVDS DRIVER DC SPECIFICATIONS									
V _{OD}	Differential Output Voltage	R _L = 100Ω		RxCLKOUT+ , TxCLKOUT- TxOUT[3:0]+, TxOUT[3:0]-	VODSEL = L	100	250	400	mV
					VODSEL = H	200	400	600	mV
V _{ODp-p}	Differential Output Voltage A – B	R _L = 100Ω			VODSEL = L		500		mVp-p
					VODSEL = H		800		mVp-p
ΔV _{OD}	Output Voltage Unbalance					1	50	mV	
V _{OS}	Offset Voltage				VODSEL = L	1.0	1.2	1.5	V
					VODSEL = H		1.2		V
ΔV _{OS}	Offset Voltage Unbalance						1	50	mV
I _{OS}	Output Short Circuit Current						-5		mA
I _{OZ}	Output TRI-STATE® Current					-10		+10	µA
DS92LV0421 Channel Link II CML DRIVER DC SPECIFICATIONS									
V _{OD}	Differential Output Voltage	R _L = 100Ω, De-emph = disabled, See Figure 6		DOUT+, DOUT-	VODSEL = 0	±225	±300	±375	mV
					VODSEL = 1	±350	±450	±550	
V _{ODp-p}	Differential Output Voltage (DOUT+) – (DOUT-)	R _L = 100Ω, De-emph = disabled, See Figure 6			VODSEL = 0		600		mVp-p
					VODSEL = 1		900		mVp-p
ΔV _{OD}	Output Voltage Unbalance	R _L = 100Ω, De-emph = disabled, VODSEL = L				1	50	mV	
V _{OS}	Offset Voltage – Single-ended At TP A & B, See Figure 5	R _L = 100Ω, De-emph = disabled			VODSEL = 0		1.65		V
					VODSEL = 1		1.575		V
ΔV _{OS}	Offset Voltage Unbalance Single-ended At TP A & B, See Figure 5	R _L = 100Ω, De-emph = disabled				1		mV	
I _{OS}	Output Short Circuit Current	DOUT+/- = 0V, De-emph = disabled	VODSEL = 0				-36		mA
R _T	Internal Termination Resistor					80		120	Ω
DS92LV0422 CHANNEL LINK II CML RECEIVER DC SPECIFICATIONS									
V _{TH}	Differential Input Threshold High Voltage	V _{CM} = +1.2V (Internal V _{BIAS})		RIN+, RIN-			+50	mV	
V _{TL}	Differential Input Threshold Low Voltage				-50		mV		
V _{CM}	Common mode Voltage, Internal V _{BIAS}					1.2		V	
R _T	Input Termination					85	100	115	Ω

DC Electrical Characteristics⁽¹⁾⁽²⁾⁽³⁾⁽⁴⁾⁽⁵⁾⁽⁶⁾ (continued)

Over recommended operating supply and temperature ranges unless otherwise specified.

Parameter	Test Conditions	Pin/Freq.	Min	Typ	Max	Units	
DS92LV0421 SUPPLY CURRENT							
I_{DDT1}	Checker Board Pattern, De-emph = disabled, VODSEL = H, See Figure 19	$V_{DD} = 1.89V$	All V_{DD} pins		84	100	mA
I_{DDIOT1}		$V_{DDIO} = 1.89V$	V_{DDIO}		3	5	mA
		$V_{DDIO} = 3.6V$			10	13	mA
I_{DDT2}	Checker Board Pattern, De-emph = disabled, VODSEL = L, See Figure 19	$V_{DD} = 1.89V$	All V_{DD} pins		77	90	mA
I_{DDIOT2}		$V_{DDIO} = 1.89V$	V_{DDIO}		3	5	mA
		$V_{DDIO} = 3.6V$			10	13	mA
I_{DDZ}	Supply Current Power-down	$V_{DD} = 1.89V$	All V_{DD} pins		100	1000	μA
I_{DDIOZ}		$V_{DDIO} = 1.89V$	V_{DDIO}		0.5	10	μA
		$V_{DDIO} = 3.6V$			1	30	μA
DS92LV0422 SUPPLY CURRENT							
I_{DD1}	Supply Current (Includes load current) 75 MHz Clock	$V_{DDn} = 1.89 V$	All $V_{DD(1:8)}$ pins		88	100	mA
I_{DDTX1}		$V_{DDTX} = 3.6 V$	V_{DDTX}		40	50	mA
I_{DDIO1}		$V_{DDIO} = 1.89 V$	V_{DDIO}		0.3	0.8	mA
		$V_{DDIO} = 3.6 V$			0.8	1.5	mA
I_{DDZ}	Supply Current Power Down	$V_{DD} = 1.89 V$	All $V_{DD(1:8)}$ pins		0.15	2	mA
I_{DDTXZ}		$V_{DDTX} = 3.6 V$	V_{DDTX}		0.01	0.1	mA
I_{DDIOZ}		$V_{DDIO} = 1.89 V$	V_{DDIO}		0.01	0.08	mA
		$V_{DDIO} = 3.6V$			0.01	0.08	mA

Switching Characteristics

Over recommended operating supply and temperature ranges unless otherwise specified.

Parameter	Test Conditions	Min	Typ	Max	Units	
DS92LV0421 CHANNEL LINK PARALLEL LVDS INPUT						
t_{RSP0}	LVDS Receiver Strobe Position-bit 0	RxCLKIN = 75 MHz, RxIN[3:0] See Figure 8	0.57	0.95	1.33	ns
t_{RSP1}	LVDS Receiver Strobe Position-bit 1		2.47	2.85	3.23	ns
t_{RSP2}	LVDS Receiver Strobe Position-bit 2		4.37	4.75	5.13	ns
t_{RSP3}	LVDS Receiver Strobe Position-bit 3		6.27	6.65	7.03	ns
t_{RSP4}	LVDS Receiver Strobe Position-bit 4		8.17	8.55	8.93	ns
t_{RSP5}	LVDS Receiver Strobe Position-bit 5		10.07	10.45	10.83	ns
t_{RSP6}	LVDS Receiver Strobe Position-bit 6		11.97	12.35	12.73	ns

Switching Characteristics (continued)

Over recommended operating supply and temperature ranges unless otherwise specified.

Parameter		Test Conditions	Min	Typ	Max	Units
DS92LV0422 CHANNEL LINK PARALLEL LVDS OUTPUT						
t_{LHT}	Low to High Transition Time	$R_L = 100\Omega$		0.3	0.6	ns
t_{HLT}	High to Low Transition Time			0.3	0.6	ns
t_{DCCJ}	Cycle-to-Cycle Output Jitter ⁽¹⁾	TxCLKOUT \pm = 10 MHz		900	2100	ps
		TxCLKOUT \pm = 75MHz		75	125	ps
t_{TTP1}	LVDS Transmitter Pulse Position for bit 1	10 – 75 MHz		0		UI ⁽²⁾
t_{TTP0}	LVDS Transmitter Pulse Position for bit 0			1		UI
t_{TTP6}	LVDS Transmitter Pulse Position for bit 6			2		UI
t_{TTP5}	LVDS Transmitter Pulse Position for bit 5			3		UI
t_{TTP4}	LVDS Transmitter Pulse Position for bit 4			4		UI
t_{TTP3}	LVDS Transmitter Pulse Position for bit 3			5		UI
t_{TTP2}	LVDS Transmitter Pulse Position for bit 2			6		UI
t_{DD}	Delay-Latency				142*T	143*T
t_{TPDD}	Power Down Delay Active to OFF	75 MHz		6	10	ns
t_{TXZR}	Enable Delay OFF to Active	75 MHz		40	55	ns
DS92LV0421 Channel Link II CML OUTPUT						
t_{HLT}	Output Low-to-High Transition Time See Figure 6	$R_L = 100\Omega$, De-emphasis = disabled, VODSEL = 0	100	200	300	ps
		$R_L = 100\Omega$, De-emphasis = disabled, VODSEL = 1	100	200	300	ps
t_{HLT}	Output High-to-Low Transition Time See Figure 7	$R_L = 100\Omega$, De-emphasis = disabled, VODSEL = 0	130	260	390	ps
		$R_L = 100\Omega$, De-emphasis = disabled, VODSEL = 1	100	200	300	ps
t_{XZD}	Ouput Active to OFF Delay, See Figure 12			5	15	ns
t_{PLD}	PLL Lock Time, See Figure 10 ⁽³⁾	$R_L = 100\Omega$		1.5	10	ms
t_{SD}	Delay - Latency, See Figure 13	$R_L = 100\Omega$		147*T	148*T	ns
t_{DJIT}	Output Total Jitter, See Figure 15	$R_L = 100\Omega$, De-Emph = disabled, RANDOM pattern		0.3		UI
λ_{STXBW}	Jitter Transfer Function -3 dB Bandwidth	RxCLKIN = 43 MHz		2.2		MHz
		RxCLKIN = 75 MHz		3		MHz
δ_{STX}	Jitter Transfer Function Peaking	RxCLKIN = 43 MHz		1		dB
		RxCLKIN = 75 MHz		1		dB
DS92LV0422 CHANNEL LINK II CML INPUT						
$t_{DDL T}$	Lock Time	SSCG = OFF, 10 MHz		7		ms
		SSCG = ON, 10 MHz		14		ms
		SSCG = OFF, 75 MHz		6		ms
		SSCG = ON, 65 MHz		8		ms
t_{DJIT}	Input Jitter Tolerance	EQ = OFF Jitter Frequency > 10 MHz		>0.45		UI

(1) t_{DCCJ} is the maximum amount of jitter between adjacent clock cycles.

(2) UI – Unit Interval is equivalent to one serialized data bit width ($1UI = 1 / 28 * PCLK$). The UI scales with PCLK frequency.

(3) t_{PLD} is the time required by the device to obtain lock when exiting power-down state with an active RxCLKIN.

Switching Characteristics (continued)

Over recommended operating supply and temperature ranges unless otherwise specified.

Parameter		Test Conditions	Min	Typ	Max	Units
DS92LV0422 LVC MOS OUTPUTS						
t_{CLH}	Low to High Transition Time	$C_L = 8$ pF LOCK pin, PASS pin		10	15	ns
t_{CHL}	High to Low Transition Time			10	15	ns
t_{PASS}	BIST PASS Valid Time, BISTEN = 1	PASS pin 10 MHz		220	230	ns
		PASS pin 75 MHz		40	65	ns
DS92LV0422 SSCG MODE						
t_{DEV}	Spread Spectrum Clocking Deviation Frequency	$TxCLKOUT = 10 - 65$ MHz, SSC[2:0] = ON	± 0.5		± 2	%
t_{MOD}	Spread Spectrum Clocking Modulation Frequency	$TxCLKOUT = 10 - 65$ MHz, SSC[2:0] = ON	8		100	kHz

Recommended Timing for the Serial Control Bus

Over recommended operating supply and temperature ranges unless otherwise specified. (See [Figure 21](#))

Parameter		Test Conditions	Min	Typ	Max	Units
f_{SCL}	SCL Clock Frequency	Standard Mode	>0		100	kHz
		Fast Mode	>0		400	kHz
t_{LOW}	SCL Low Period ⁽¹⁾	Standard Mode	4.7			μ s
		Fast Mode	1.3			μ s
t_{HIGH}	SCL High Period ⁽¹⁾	Standard Mode	4.0			μ s
		Fast Mode	0.6			μ s
$t_{HD:STA}$	Hold time for a START or a repeated START condition	Standard Mode	4.0			μ s
		Fast Mode	0.6			μ s
$t_{SU:STA}$	Set Up time for a START or a repeated START condition	Standard Mode	4.7			μ s
		Fast Mode	0.6			μ s
$t_{HD:DAT}$	Data Hold Time	Standard Mode	0		3.45	μ s
		Fast Mode	0		0.9	μ s
$t_{SU:DAT}$	Data Set Up Time	Standard Mode	250			μ s
		Fast Mode	100			μ s
$t_{SU:STO}$	Set Up Time for STOP	Standard Mode	4.0			μ s
		Fast Mode	0.6			μ s
t_{BUF}	Bus Free Time between STOP and START	Standard Mode	4.7			μ s
		Fast Mode	1.3			μ s
t_r	SCL & SDA Rise Time	Standard Mode			1000	ns
		Fast Mode			300	ns
t_f	SCL & SDA Fall Time	Standard Mode			300	ns
		Fast Mode			300	ns

(1) t_{DPJ} is the maximum amount the period is allowed to deviate over many samples.

DC and AC Serial Control Bus Characteristics

Over recommended operating supply and temperature ranges unless otherwise specified.

Parameter		Test Conditions	Min	Typ	Max	Units
V _{IH}	Input High Level	SDA and SCL	0.7* V _{DDIO}		V _{DDIO}	V
V _{IL}	Input Low Level Voltage	SDA and SCL	GND		0.3* V _{DDIO}	V
V _{HY}	Input Hysteresis			>50		mV
V _{OL}		SDA, IOL = 3mA	0		0.36	V
I _{in}		SDA or SCL, V _{in} = V _{DDIO} or GND	-10		+10	μA
t _R	SDA RiseTime – READ	SDA, RPU = X, C _b ≤ 400pF,		800		ns
t _F	SDA Fall Time – READ			50		ns
t _{SU:DAT}	Set Up Time – READ			540		ns
t _{HD:DAT}	Hold Up Time – READ			600		ns
t _{SP}	Input Filter			50		ns
C _{in}	Input Capacitance	SDA or SCL		<5		pF

AC Timing Diagrams and Test Circuits

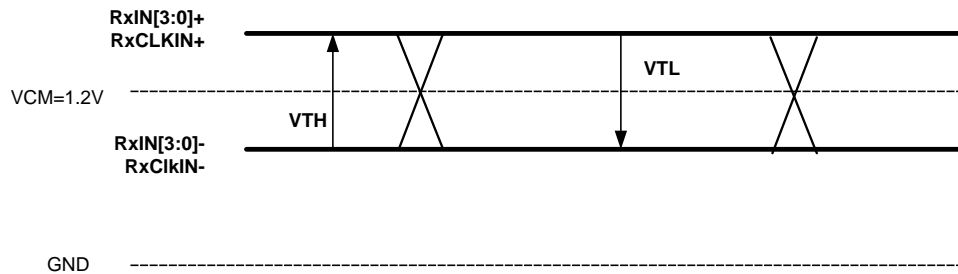

Figure 4. Channel Link DC VTH/VTL Definition

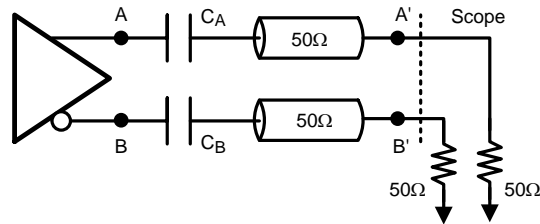

Figure 5. Output Test Circuit

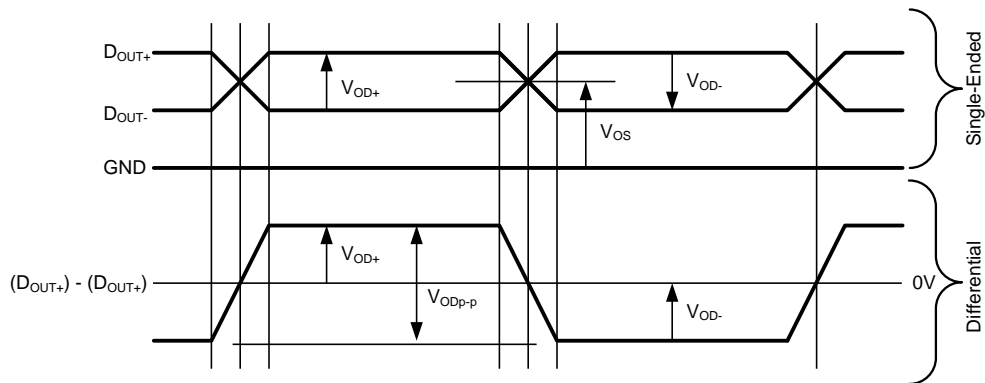

Figure 6. Output Waveforms

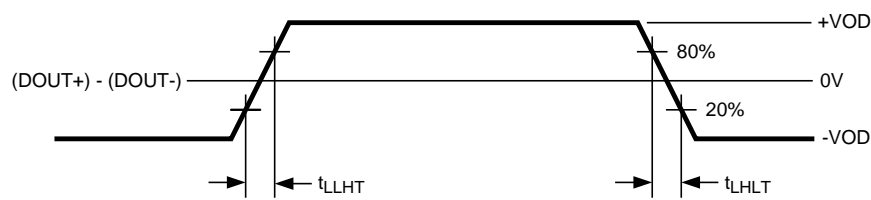

Figure 7. Output Transition Times

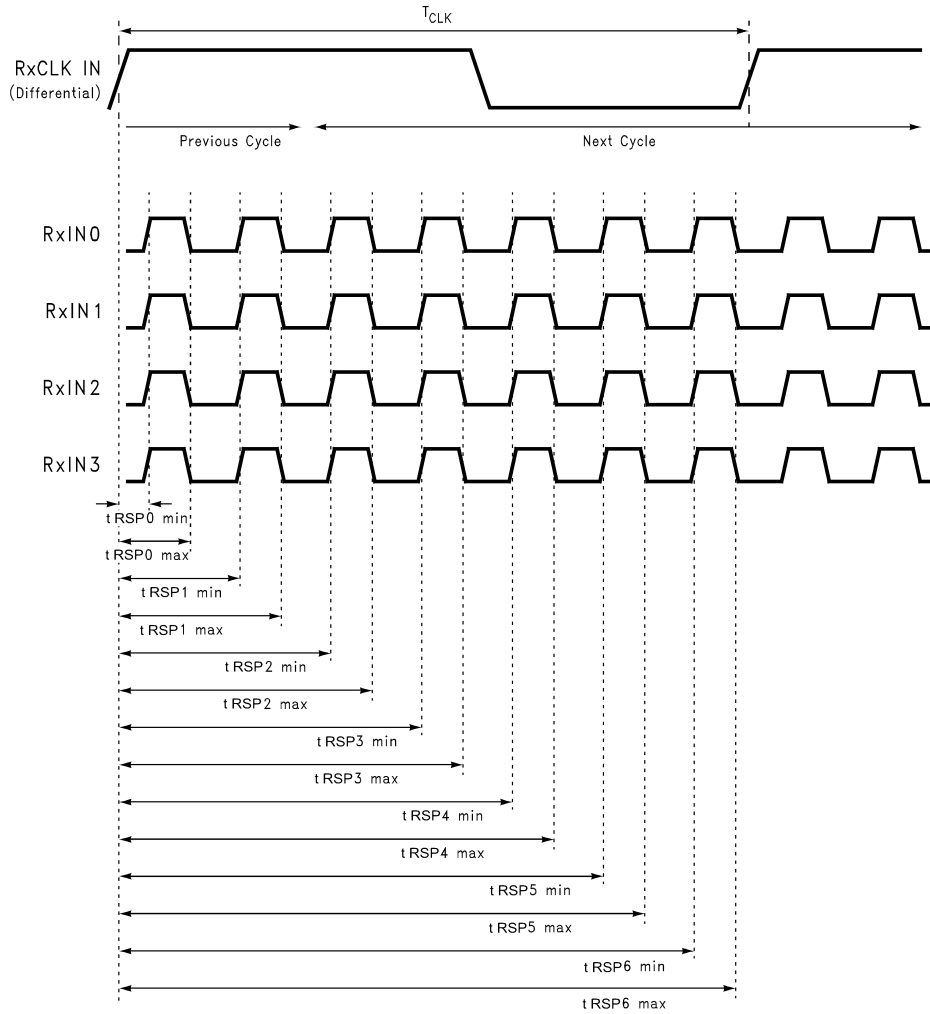

Figure 8. DS92LV0421 Channel Link Receiver Strobe Positions

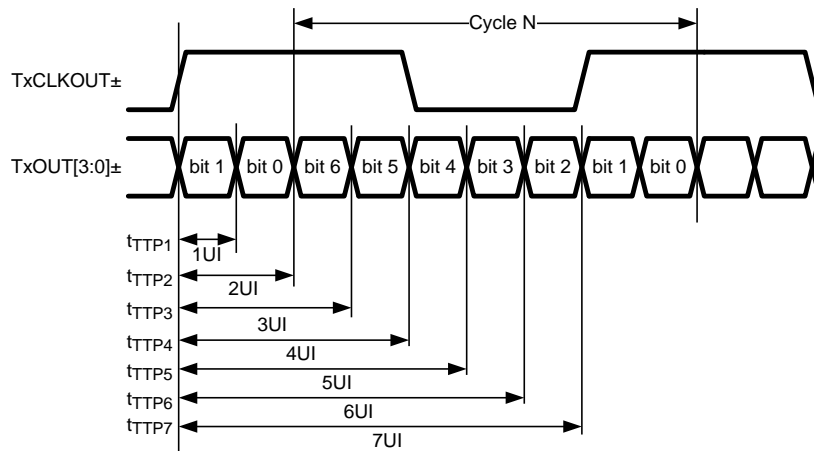

Figure 9. DS92LV0422 LVDS Transmitter Pulse Positions

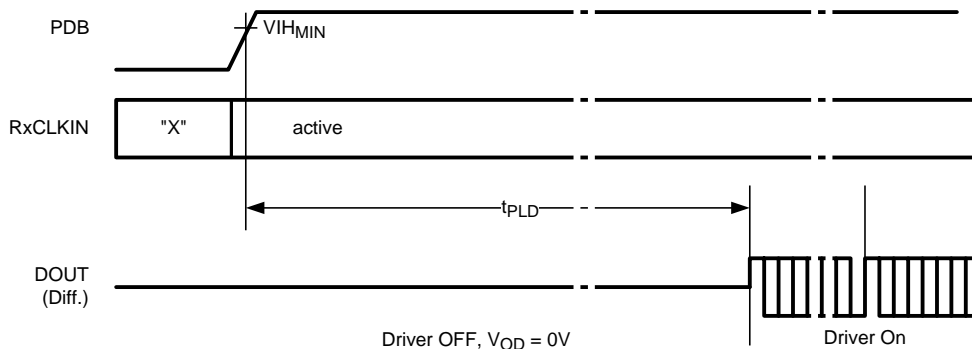

Figure 10. DS92LV0421 Lock Time

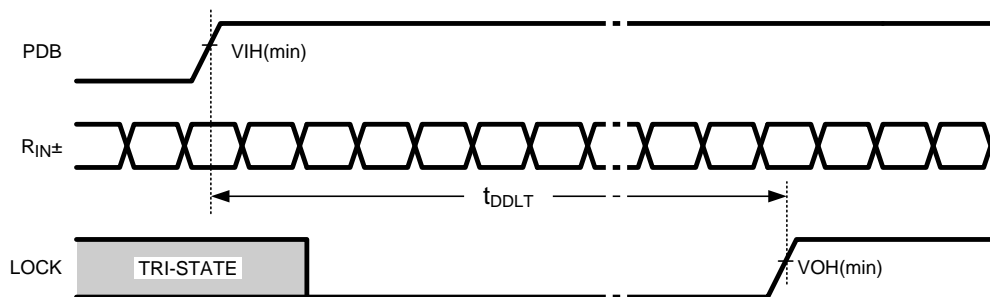

Figure 11. DS92LV0422 Lock Time

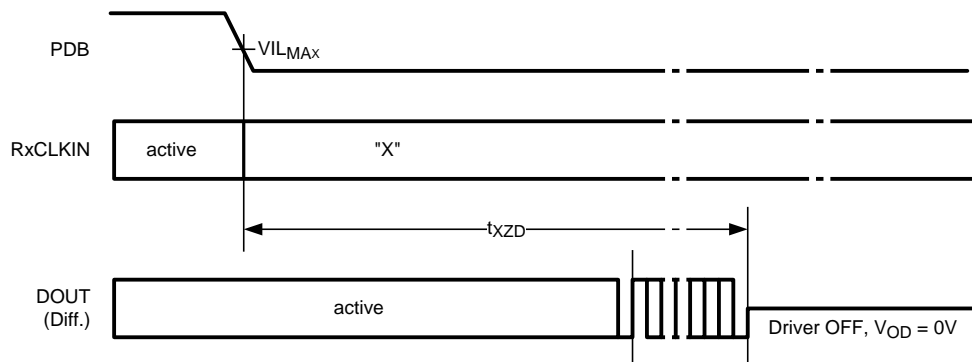

Figure 12. DS92LV0421 Disable Time

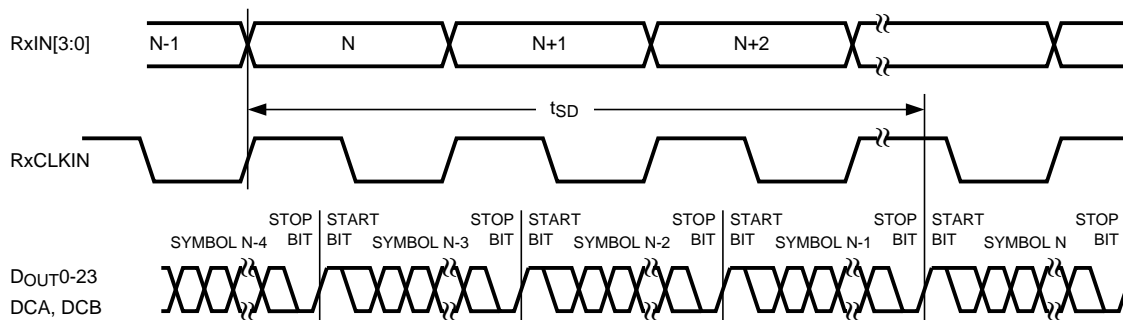

Figure 13. DS92LV0421 Latency Delay

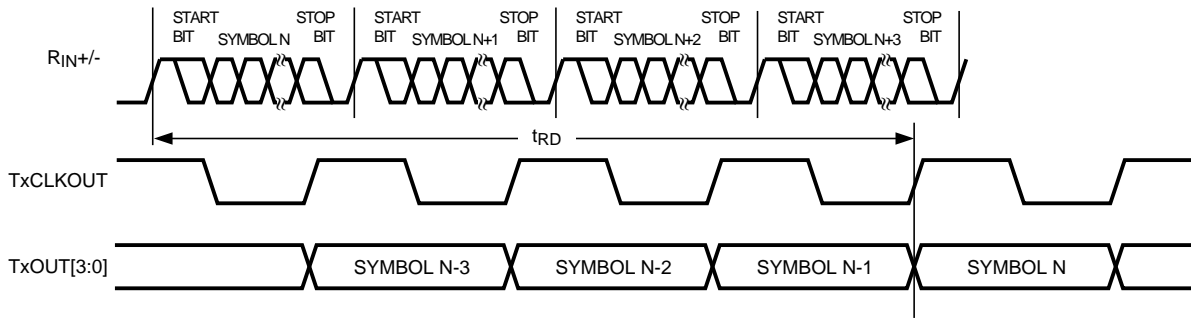

Figure 14. DS92LV0422 Latency Delay

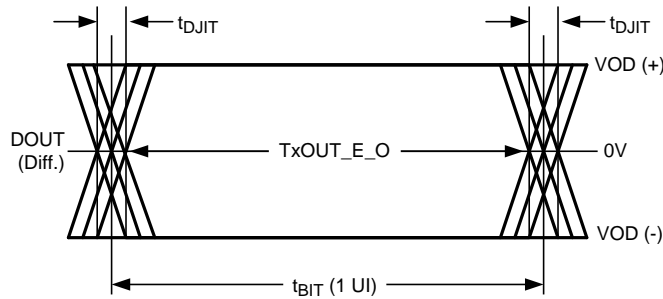
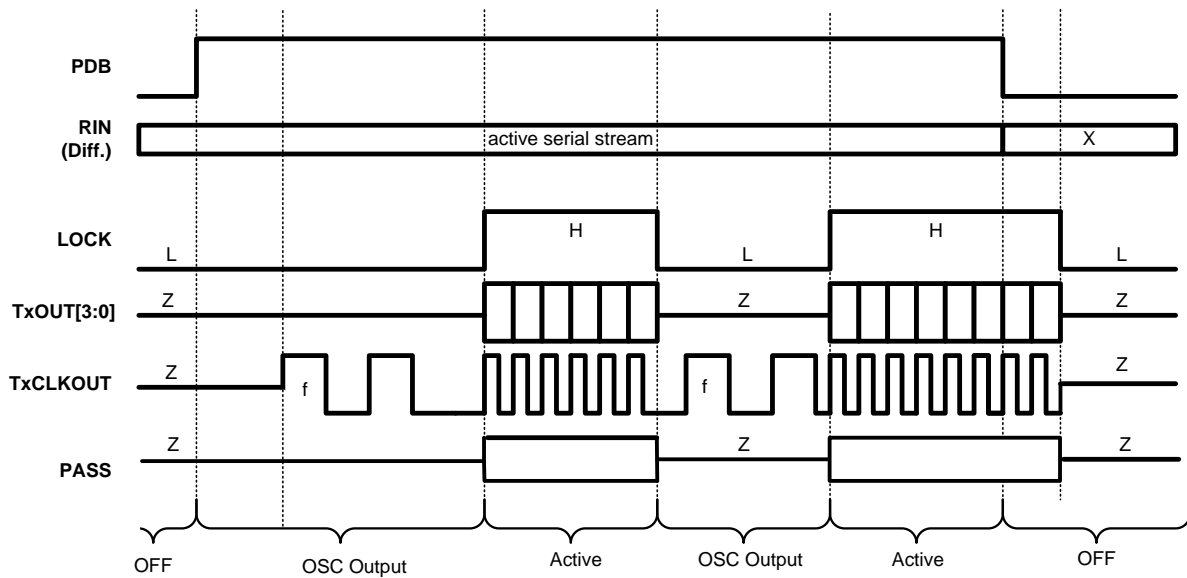

Figure 15. DS92LV0421 Output Jitter



CONDITIONS: OEN = H, OSS_SEL = H, and OSC_SEL not equal to 000.

Figure 16. DS92LV0422 Output State Diagram

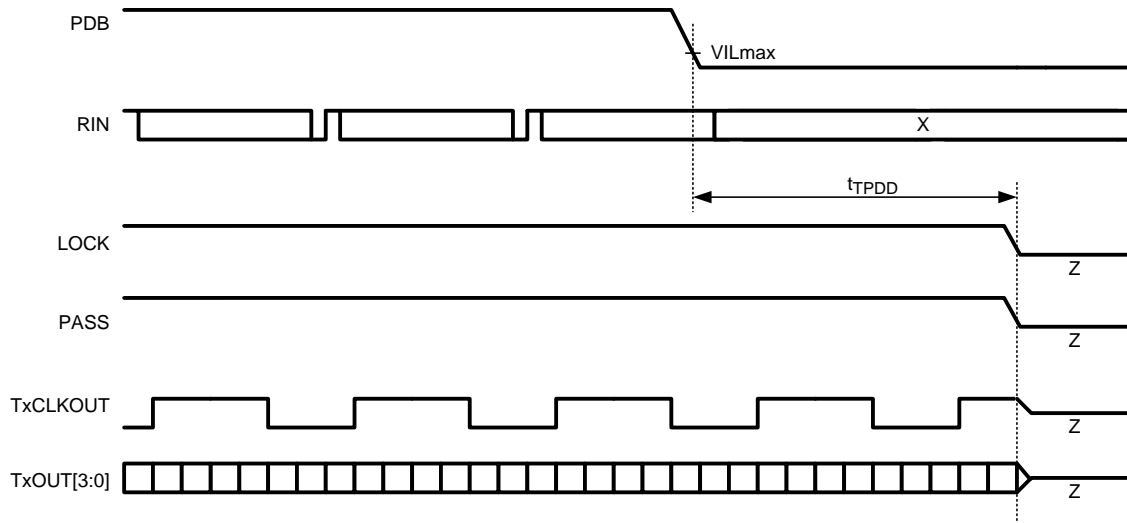

Figure 17. DS92LV0422 Power Down Delay

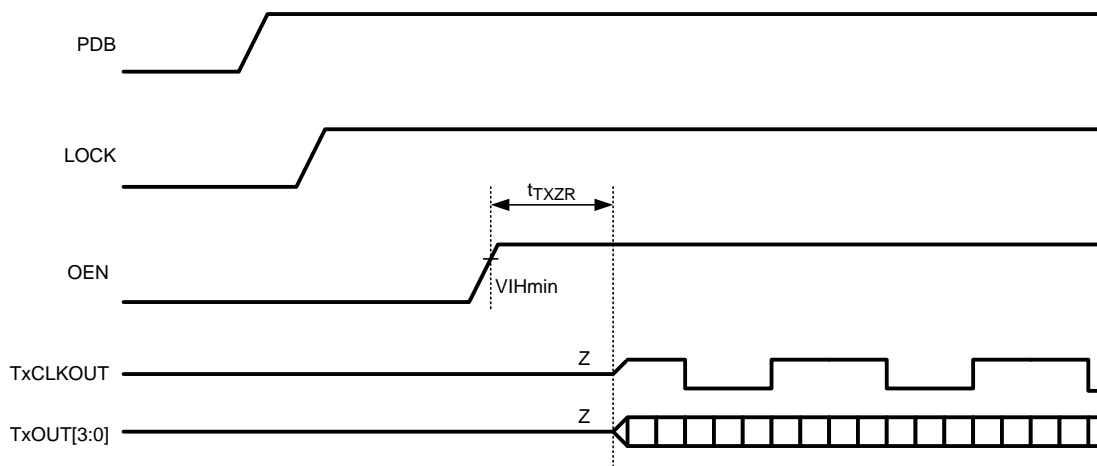

Figure 18. DS92LV0422 Enable Delay

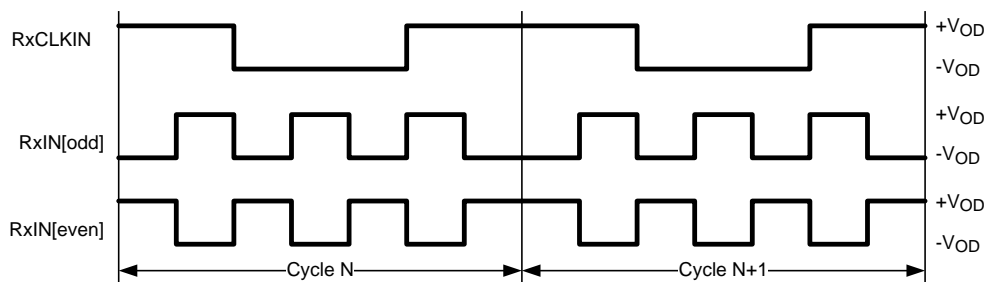

Figure 19. Checkerboard Data Pattern

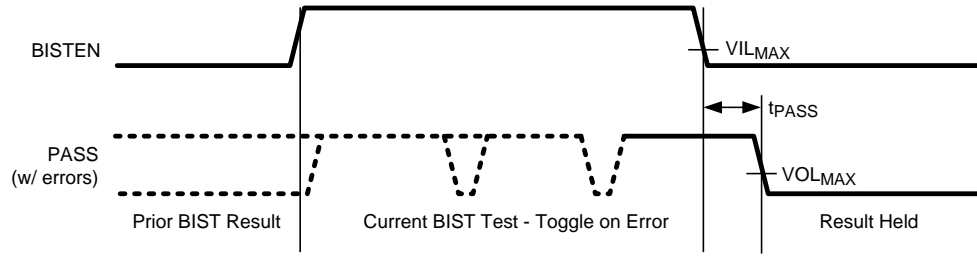

Figure 20. BIST PASS Waveform

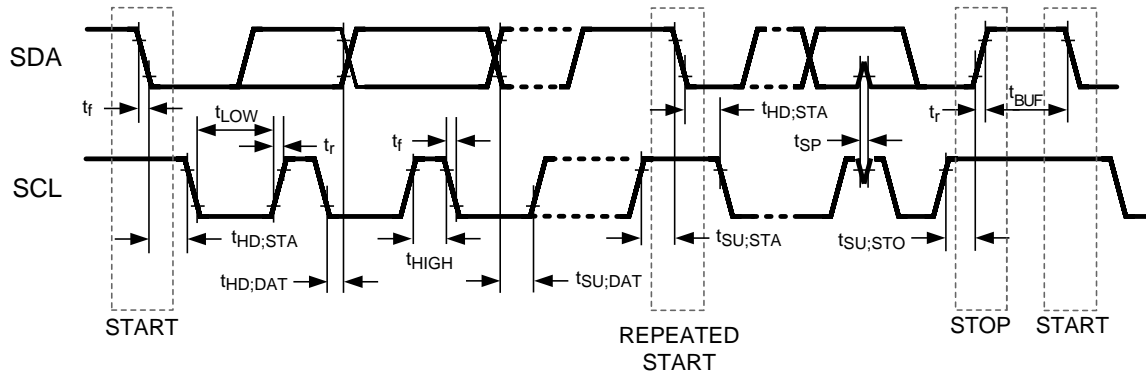

Figure 21. Serial Control Bus Timing Diagram

FUNCTIONAL DESCRIPTION

The DS92LV0421 / DS92LV0422 chipset transmits and receives 24-bits of data and 3 control signals, formatted as Channel Link LVDS data, over a single serial CML pair operating at 280 Mbps to 2.1 Gbps serial line rate. The serial stream contains an embedded clock, video control signals and is DC-balance to enhance signal quality and supports AC coupling.

The Des can attain lock to a data stream without the use of a separate reference clock source, which simplifies system complexity and overall cost. The Des also synchronizes to the Ser regardless of the data pattern, delivering true automatic “plug and lock” performance. It can lock to the incoming serial stream without the need of special training patterns or sync characters. The Des recovers the clock and data by extracting the embedded clock information, validating and then deserializing the incoming data stream providing a parallel Channel Link LVDS bus to the display, ASIC, or FPGA.

The DS92LV0421 / DS92LV0422 chipset can operate with up to 24 bits of raw data with three slower speed control bits encoded within the serial data stream. For applications that require less the maximum 24 pclk speed bit spaces, the user will need to ensure that all unused bit spaces or parallel LVDS channels are set to valid logic states, as all parallel lanes and 27 bit spaces will always be sampled.

See [Block Diagrams](#).

Parallel LVDS Data Transfer

The DS92LV0421/DS92LV0422 can be configured to accept/transmit 24-bit data with 2 different mapping schemes: The normal Channel Link LVDS format (MSBs on LVDS channel 3) can be selected by configuring the MAPSEL pin to HIGH. See [Figure 14](#) for the normal Channel Link LVDS mapping. An alternate mapping scheme is available (LSBs on LVDS channel 3) by configuring the MAPSEL pin to LOW. See [Figure 15](#) for the alternate LVDS mapping. The mapping schemes can also be selected by register control.

The alternate mapping scheme is useful in some applications where the receiving system, typically a display, requires that the LSBs for the 24-bit color data be sent on LVDS channel 3.

Serial Data Transfer

The DS92LV0421 transmits a pixel of data in the following format: C1 and C0 represent the embedded clock in the serial stream. C1 is always HIGH and C0 is always LOW. b[23:0] contain the scrambled RGB data. DCB is the DC-Balanced control bit. DCB is used to minimize the short and long-term DC bias on the signal lines. This bit determines if the data is unmodified or inverted. DCA is used to validate data integrity in the embedded data stream and can also contain unencoded control (VS,HS,DE). Both DCA and DCB coding schemes are generated by the DS92LV0421 and decoded by the paring deserializer automatically. [Figure 22](#) illustrates the serial stream per PCLK cycle.

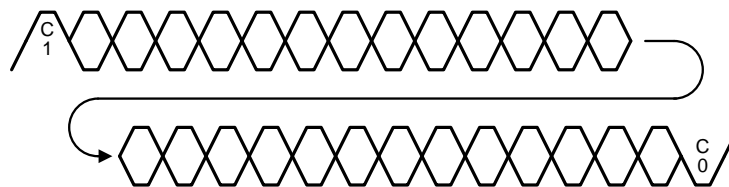

Figure 22. Channel Link II Serial Stream

OPERATING MODES AND BACKWARD COMPATIBILITY (CONFIG[1:0])

The DS92LV0421 and DS92LV0422 are backward compatible with previous generations of Texas Instruments Ser/Des. Configuration modes are provided for backwards compatibility with the DS90C241/DS90C124 and also the DS90UR241/DS90UR124 and DS99R241/DS99R124 by setting the respective mode with the CONFIG[1:0] pins as shown in [Table 1](#) and [Table 2](#). The selection also determine whether the Video Control Signal filter feature is enabled or disabled in Normal mode. Backward compatibility modes are selectable through the control pins only. The Control Signal Filter can be selected by pin or through register programming.

Table 1. DS92LV0421 Configuration Modes

CON FIG1	CON FIG0	Mode	Des Device
L	L	Normal Mode, Control Signal Filter disabled	DS92LV0422, DS92LV2422
L	H	Normal Mode, Control Signal Filter enabled	DS92LV0422, DS92LV2422
H	L	Backwards Compatible	DS90UR124, DS99R124
H	H	Backwards Compatible	DS90C124

Table 2. DS92LV0422 Configuration Modes

CON FIG1	CON FIG0	Mode	Des Device
L	L	Normal Mode, Control Signal Filter disabled	DS92LV0421, DS92LV2421
L	H	Normal Mode, Control Signal Filter enabled	DS92LV0421, DS92LV2421
H	L	Backwards Compatible	DS90UR241, DS99R421
H	H	Backwards Compatible	DS90C241

BIT MAPPING SELECT

The DS92LV0421 and DS92LV0422 can be configured to accept the LVDS parallel data with 2 different mapping schemes: LSBs on RxIN[3] shown in Figure 23 or MSBs on RxIN[3] shown in Figure 24. The user selects which mapping scheme is controlled by MAPSEL pin or by Register.

IMPORTANT NOTE — while the LVDS interface has 28 bits defined, only 27 bits are recovered by the SER and sent to the DES. This supports 24 bit RGB plus the three video control signals. The 28th bit is not sampled, sent or recovered.

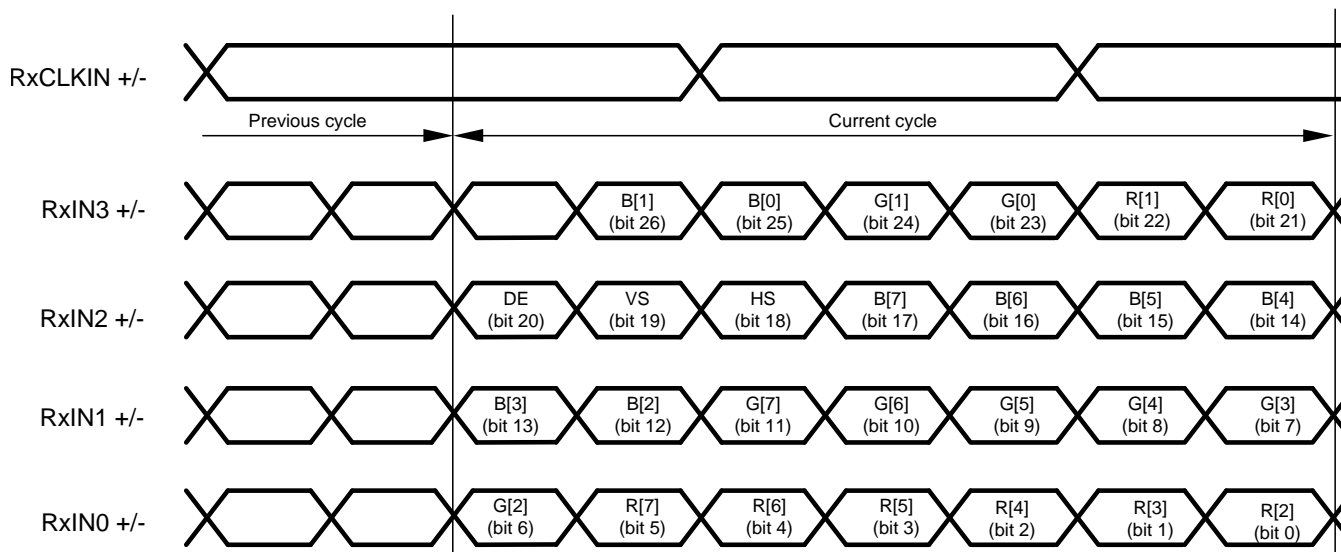

Figure 23. 8-bit Channel Link Mapping: LSB's on RxIN3

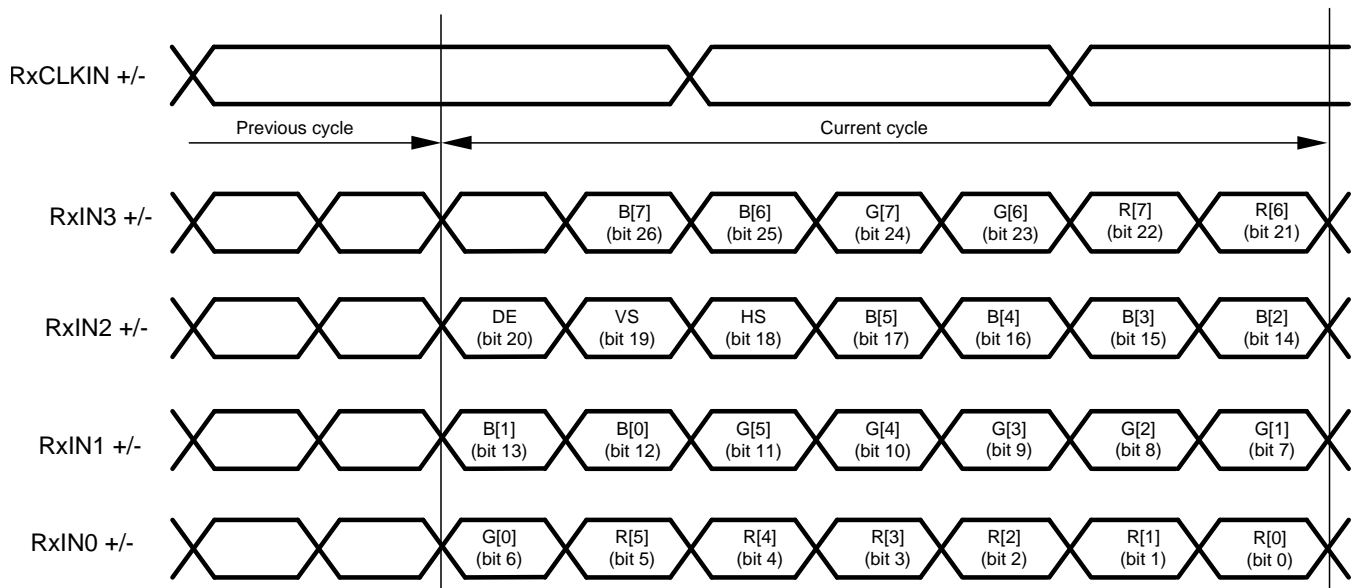

Figure 24. 8-bit Channel Link Mapping: MSB's on RxIN3

Video Control Signal Filter

The three control bits can be used to communicate any low speed signal. The most common use for these bits is in the display or machine vision applications. In a display application these bits are typically assigned as: Bit 26 – DE, Bit 24 – HS, Bit 25 – VS. In the machine vision standard, Camera Link, these bits are typically assigned: Bit 26 – DVAL, Bit 24 – LVAL, Bit 25 – FVAL.

When operating the devices in Normal Mode, the Video Control Signals (DE, HS, VS) have the following restrictions:

- Normal Mode with Control Signal Filter Enabled:
 - DE and HS — Only 2 transitions per 130 clock cycles are transmitted, the transition pulse must be 3 PCLK or longer.
- Normal Mode with Control Signal Filter Disabled:
 - DE and HS — Only 2 transitions per 130 clock cycles are transmitted, no restriction on minimum transition pulse.
- VS — Only 1 transition per 130 clock cycles are transmitted, minimum pulse width is 130 clock cycles.

Video Control Signals are defined as low frequency signals with limited transitions. Glitches of a control signal can cause a visual display error. This feature allows for the chipset to validate and filter out any high frequency noise on the control signals. See [Figure 25](#).

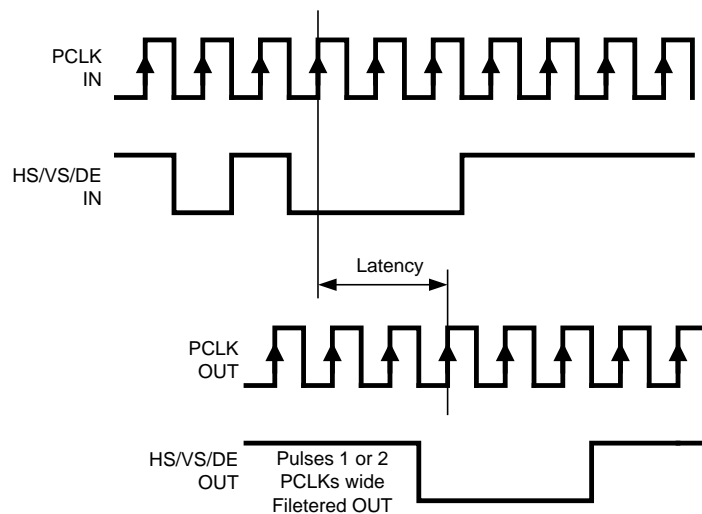

Figure 25. Video Control Signal Filter Waveform

SERIALIZER Functional Description

The Ser converts a Channel Link LVDS clock and data bus to a single serial output data stream, and also acts as a signal generator for the chipset Built In Self Test (BIST) mode. The device can be configured via external pins or through the optional serial control bus. The Ser features enhanced signal quality on the link by supporting: a selectable VOD level, a selectable de-emphasis signal conditioning and also the Channel Link II data coding that provides randomization, scrambling, and DC Balancing of the data. The Ser includes multiple features to reduce EMI associated with display data transmission. This includes the randomization and scrambling of the serial data and also the system spread spectrum clock support. The Ser features power saving features with a sleep mode, auto stop clock feature, and optional 1.8 V or 3.3V I/O compatibility.

See also [Optional Serial Bus Control](#) and [Built In Self Test \(BIST\)](#).

EMI Reduction Features

Data Randomization & Scrambling

Channel Link II Ser / Des feature a 3 step encoding process which enables the use of AC coupled interconnects and also helps to manage EMI. The serializer first passes the parallel data through a scrambler which randomizes the data. The randomized data is then DC balanced. The DC balanced and randomized data then goes through a bit shuffling circuit and is transmitted out on the serial line. This encoding process helps to prevent static data patterns on the serial stream. The resulting frequency content of the serial stream ranges from the parallel clock frequency to the nyquist rate. For example, if the Ser / Des chip set is operating at a parallel clock frequency of 50 MHz, the resulting frequency content of serial stream ranges from 50 MHz to 700 MHz ($50 \text{ MHz} * 28 \text{ bits} = 1.4 \text{ Gbps} / 2 = 700 \text{ MHz}$).

Ser — Spread Spectrum Compatibility

The RxCLKIN of the Channel Link input is capable of tracking spread spectrum clocking (SSC) from a host source. The RxCLKIN will accept spread spectrum tracking up to 35kHz modulation and ± 0.5 , ± 1 or $\pm 2\%$ deviations (center spread). The maximum conditions for the RxCLKIN input are: a modulation frequency of 35kHz and amplitude deviations of $\pm 2\%$ (4% total).

Ser — Integrated Signal Conditioning Features

Ser — VOD Select (VODSEL)

The DS92LV0421 differential output voltage may be increased by setting the VODSEL pin High. When VODSEL is Low, the DC VOD is at the standard (default) level. When VODSEL is High, the DC VOD is increased in level. The increased VOD is useful in extremely high noise environments and also on extra long cable length applications. When using de-emphasis it is recommended to set VODSEL = H to avoid excessive signal attenuation especially with the larger de-emphasis settings. This feature may be controlled by the external pin or by register.

Table 3. Ser — Differential Output Voltage

Input	Effect	
	VOD mV	VOD mVp-p
H	±420	840
L	±280	560

Ser — De-Emphasis (De-Emph)

The De-Emph pin controls the amount of de-emphasis beginning one full bit time after a logic transition that the device drives. This is useful to counteract loading effects of long or lossy cables. This pin should be left open for standard switching currents (no de-emphasis) or if controlled by register. De-emphasis is selected by connecting a resistor on this pin to ground, with R value between 0.5 kΩ to 1 MΩ, or by register setting. When using De-Emphasis it is recommended to set VODSEL = H.

Table 4. De-Emphasis Resistor Value

Resistor Value (kΩ)	De-Emphasis Setting
Open	Disabled
0.6	- 12 dB
1.0	- 9 dB
2.0	- 6 dB
5.0	- 3 dB

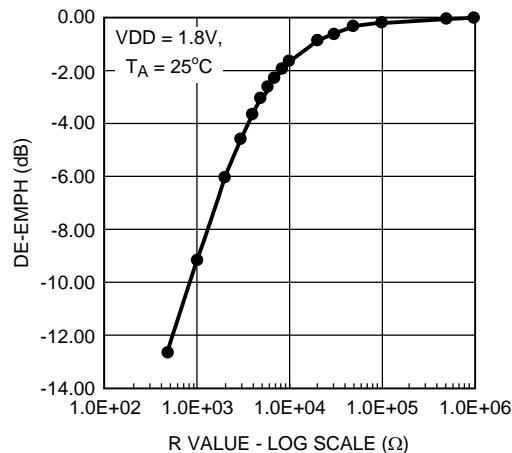

Figure 26. De-Emph vs. R value

Power Saving Features

Ser — Power Down Feature (PDB)

The DS92LV0421 has a PDB input pin to ENABLE or POWER DOWN the device. This pin is controlled by the host and is used to save power, disabling the link when the display is not needed. In the POWER DOWN mode, the high-speed driver outputs are both pulled to VDD and present a 0V VOD state. Note – in POWER DOWN, the optional Serial Bus Control Registers are **RESET**.

Ser — Stop Clock Feature

The DS92LV0421 will enter a low power SLEEP state when the RxCLKIN is stopped. A STOP condition is detected when the input clock frequency is less than 3 MHz. The clock should be held at a static Low or high state. When the RxCLKIN starts again, the device will then lock to the valid input RxCLKIN and then transmits the RGB data to the deserializer. Note – in STOP CLOCK SLEEP, the optional Serial Bus Control Registers values are **RETAINED**.

1.8V or 3.3V VDDIO Operation

The DS92LV0421 parallel control bus can operate with 1.8 V or 3.3 V levels (V_{DDIO}) for host compatibility. The 1.8 V levels will offer a system power savings.

Optional Serial Bus Control

Please see the following section on the optional Serial Bus Control Interface.

Optional BIST Mode

Please see the following section on the chipset BIST mode for details.

Deserializer Functional Description

The Des converts a single input serial data stream to a wide parallel output bus, and also provides a signal check for the chipset Built In Self Test (BIST) mode. The device can be configured via external pins and strap pins or through the optional serial control bus. The Des features enhance signal quality on the link with an integrated equalizer on the serial input and Channel Link II data encoding which provides randomization, scrambling, and DC balancing of the data. The Des includes multiple features to reduce EMI associated with data transmission. This includes the randomization and scrambling of the data, the output spread spectrum clock generation (SSCG) support and output clock and data slew rate select. The Des features power saving features with a power down mode, and optional LVCMOS (1.8 V) interface compatibility.

Oscillator Output — Optional

The DS92LV0422 provides an optional TxCLKOUT when the input clock (serial stream) has been lost. This is based on an internal oscillator. The frequency of the oscillator may be selected. This feature may be controlled by the external pin or through the registers.

CLOCK-DATA RECOVERY STATUS FLAC (LOCK), OUTPUT ENABLE (OEN) AND OUTPUT STATE SELECT (SS_SEL)

When PDB is driven HIGH, the CDR PLL begins locking to the serial input, LOCK is LOW and the Channel Link interface state is determined by the state of the OSS_SEL pin.

After the DS92LV0422 completes its lock sequence to the input serial data, the LOCK output is driven HIGH, indicating valid data and clock recovered from the serial input is available on the Channel Link outputs. The TxCLKOUT output is held at its current state at the change from OSC_CLK (if this is enabled via OSC_SEL) to the recovered clock (or vice versa). Note that the Channel Link outputs may be held in an inactive state (TRISTATE®) through the use of the Output Enable pin (OEN).

If there is a loss of clock from the input serial stream, LOCK is driven LOW and the state of the outputs are based on the OSS_SEL setting (configuration pin or register).

Table 5. Des Output State Table

INPUTS			OUTPUTS	
PDB	OEN	OSS_SEL	LOCK	OTHER OUTPUTS
L	X	X	X	TxCLKOUT is TRI-STATE TxOUT[3:0] are TRI-STATE PASS is TRI-STATE
L	X	L	L	TxCLKOUT is TRI-STATE TxOUT[3:0] are TRI-STATE PASS is HIGH
H	L	H	L	TxCLKOUT is TRI-STATE TxOUT[3:0] are TRI-STATE PASS is TRI-STATE
H	H	H	L	TxCLKOUT is TRI-STATE or OSC Output through Register bit TxOUT[3:0] are TRI-STATE PASS is TRI-STATE
H	L	X	H	TxCLKOUT is TRI-STATE TxOUT[3:0] are TRI-STATE PASS is HIGH
H	H	X	H	TxCLKOUT is Active TxOUT[3:0] are Active PASS is Active (Normal operating mode)

Des — Integrated Signal Conditioning Features — Des

Des — Common Mode Filter Pin (CMF) — Optional

The Des provides access to the center tap of the internal termination. A capacitor may be placed on this pin for additional common-mode filtering of the differential pair. This can be useful in high noise environments for additional noise rejection capability. A 0.1 µF capacitor may be connected to this pin to Ground.

Des — Input Equalizer Gain (EQ)

The Des can enable receiver input equalization of the serial stream to increase the eye opening to the Des input. Note this function cannot be seen at the RxIN+/- input. The equalization feature may be controlled by the external pin or by register.

Table 6. Receiver Equalization Configuration Table

EQ (Strap Option)	Effect
L	OFF, ~1.625 dB
H	~13 dB

EMI Reduction Features

Des — VOD Select (VODSEL)

The differential output voltage of the Channel Link interface is controlled by the VODSEL input.

Table 7. Des — Differential Output Voltage Table

VODSEL	Result
L	VOD is 250 mV TYP (500 mVp-p)
H	VOD is 400 mV TYP (800 mVp-p)

Des — SSCG Generation — Optional

The Des provides an internally generated spread spectrum clock (SSCG) to modulate its outputs. Both clock and data outputs are modulated. This will aid to lower system EMI. Output SSCG deviations to ±2% (4% total) at up to 100 kHz modulations is available. See [Table 8](#). This feature may be controlled by external STRAP pins or by register.

Table 8. SSCG Configuration (LF_MODE = L) — Des Output

SSC[3:0] Inputs LF_MODE = L (20 — 65 MHz)				Result	
SSC3	SSC2	SSC1	SSC0	fdev (%)	fmod (kHz)
L	L	L	L	N/A	CLK/2168
L	L	L	H	±0.5	
L	L	H	L	±1.0	
L	L	H	H	±1.5	
L	H	L	L	±2.0	
L	H	L	H	±0.5	CLK/1300
L	H	H	L	±1.0	
L	H	H	H	±1.5	
H	L	L	L	±2.0	
H	L	L	H	±0.5	CLK/868
H	L	H	L	±1.0	
H	L	H	H	±1.5	
H	H	L	L	±2.0	
H	H	L	H	±0.5	CLK/650
H	H	H	L	±1.0	
H	H	H	H	±1.5	

Table 9. SSCG Configuration (LF_MODE = H) — Des Output

SSC[3:0] Inputs LF_MODE = H (10 — 20 MHz)				Result	
SSC3	SSC2	SSC1	SSC0	fdev (%)	fmod (kHz)
L	L	L	L	N/A	CLK/620
L	L	L	H	±0.5	
L	L	H	L	±1.0	
L	L	H	H	±1.5	
L	H	L	L	±2.0	
L	H	L	H	±0.5	CLK/370
L	H	H	L	±1.0	
L	H	H	H	±1.5	
H	L	L	L	±2.0	
H	L	L	H	±0.5	CLK/258
H	L	H	L	±1.0	
H	L	H	H	±1.5	
H	H	L	L	±2.0	
H	H	L	H	±0.5	CLK/192
H	H	H	L	±1.0	
H	H	H	H	±1.5	

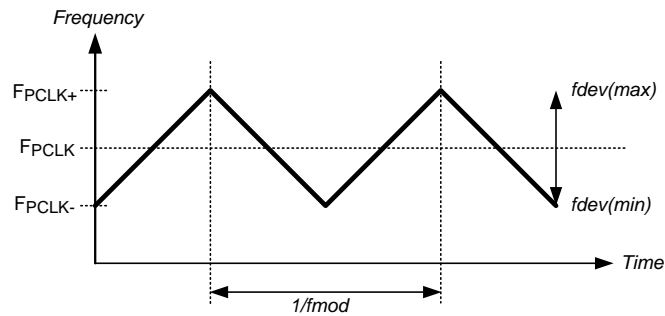

Figure 27. SSCG Waveform

Power Saving Features

Des — Power Down Feature (PDB)

The DS92LV0422 has a PDB input pin to ENABLE or POWER DOWN the device. This pin is controlled by the host and is used to save power, disabling the Des when the display is not needed. An auto detect mode is also available. In this mode, the PDB pin is tied HIGH and the Des will enter POWER DOWN when the serial stream stops. When the serial stream starts up again, the Des will lock to the input stream and assert the LOCK pin and output valid data. In the POWER DOWN mode, the LVDS data and clock output states are determined by the OSS_SEL status. Note – in POWER DOWN, the optional Serial Bus Control Registers are **RESET**.

Des — Stop Stream SLEEP Feature

The DS92LV0422 will enter a low power SLEEP state when the input serial stream is stopped. A STOP condition is detected when the embedded clock bits are not present. When the serial stream starts again, the Des will then lock to the incoming signal and recover the data. Note – in STOP CLOCK SLEEP, the optional Serial Bus Control Registers values are **RETAINED**.

1.8V or 3.3V VDDIO Operation

The DS92LV0422 parallel control bus can operate with 1.8 V or 3.3 V levels (V_{DDIO}) for host compatibility. The 1.8 V levels will offer a system power savings.

Built In Self Test (BIST)

An optional At-Speed Built In Self Test (BIST) feature supports the testing of the high-speed serial link. This is useful in the prototype stage, equipment production, in-system test and also for system diagnostics. In the BIST mode only a input clock is required along with control to the Ser and Des BISTEN input pins. The Ser outputs a test pattern (PRBS7) and drives the link at speed. The Des detects the PRBS7 pattern and monitors it for errors. A PASS output pin toggles to flag any payloads that are received with 1 to 24 errors. Upon completion of the test, the result of the test is held on the PASS output until reset (new BIST test or Power Down). A high on PASS indicates NO ERRORS were detected. A Low on PASS indicates one or more errors were detected. The duration of the test is controlled by the pulse width applied to the Des BISTEN pin.

Inter-operability is supported between this Channel Link II device and all Channel Link II generations (Gen 1/2/3) — see respective datasheets for details on entering BIST mode and control.

Sample BIST Sequence

See [Figure 28](#) for the BIST mode flow diagram.

Step 1: Place the serializer in BIST Mode by setting Ser BISTEN = H. The BIST Mode is enabled via the BISTEN pin. An RxCLKIN is required for all the Ser options. When the deserializer detects the BIST mode pattern and command the parallel data and control signal outputs are shut off.

Step 2: Place the deserializer in BIST mode by setting the BISTEN = H. The Des is now in the BIST mode and checks the incoming serial payloads for errors. If an error in the payload (1 to 24) is detected, the PASS pin will switch low for one half of the clock period. During the BIST test, the PASS output can be monitored and counted to determine the payload error rate.

Step 3: To Stop the BIST mode, the deserializer BISTEN pin is set Low. The deserializer stops checking the data and the final test result is held on the PASS pin. If the test ran error free, the PASS output will be High. If there was one or more errors detected, the PASS output will be Low. The PASS output state is held until a new BIST is run, the device is RESET, or Powered Down. The BIST duration is user controlled by the duration of the BISTEN signal.

Step 4: To return the link to normal operation, the ser and des BISTEN input are set Low. The Link returns to normal operation.

Figure 29 shows the waveform diagram of a typical BIST test for two cases. Case 1 is error free, and Case 2 shows one with multiple errors. In most cases it is difficult to generate errors due to the robustness of the link (differential data transmission etc.), thus they may be introduced by greatly extending the cable length, faulting the interconnect, reducing signal condition enhancements (De-Emphasis, VODSEL, or deserializer Equalization).

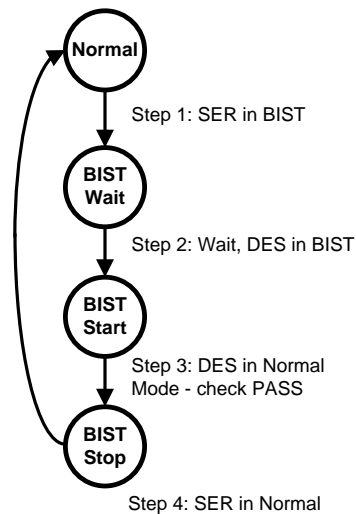

Figure 28. BIST Mode Flow Diagram

BER Calculations

It is possible to calculate the approximate Bit Error Rate (BER). The following is required:

- Pixel Clock Frequency (MHz)
- BIST Duration (seconds)
- BIST test Result (PASS)

The BER is less than or equal to one over the product of 24 times the RxCLKIN rate times the test duration. If we assume a 65MHz RxCLKIN, a 10 minute (600 second) test, and a PASS, the BERT is $\leq 1.07 \times 10^{-12}$

The BIST mode runs a check on the data payload bits. The LOCK pin also provides a link status. If the recovery of the C0 and C1 bits does not reconstruct the expected clock signal, the LOCK pin will switch Low. The combination of the LOCK and At-Speed BIST PASS pin provides a powerful tool for system evaluation and performance monitoring.

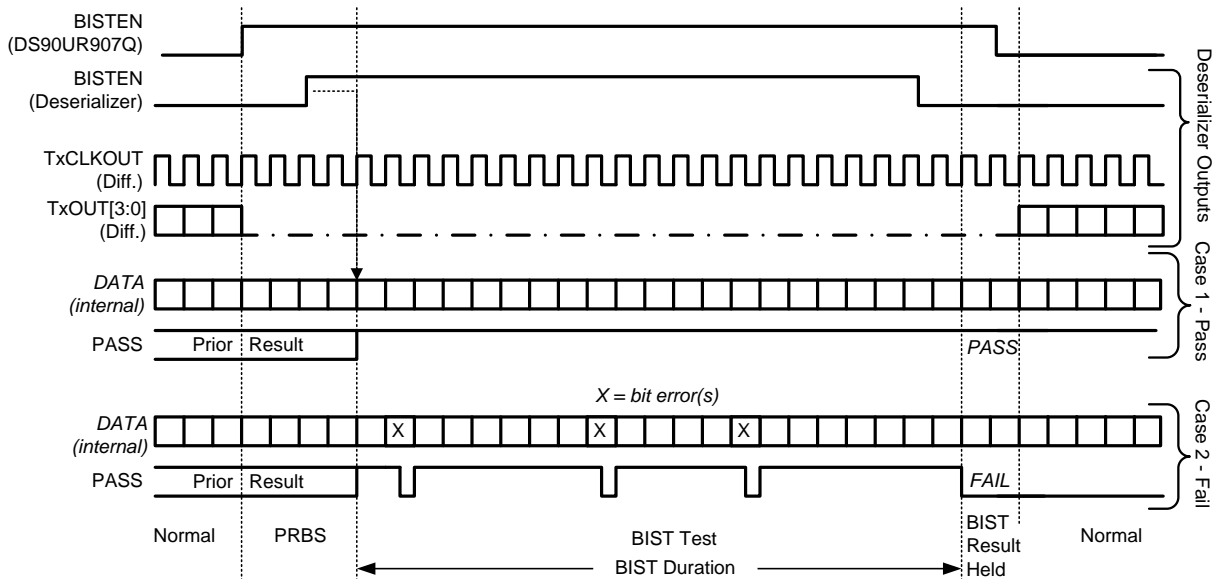

Figure 29. BIST Waveforms

Optional Serial Bus Control

The DS92LV0421 and DS92LV0422 may be configured by the use of a serial control bus that is I2C protocol compatible. By default, the I2C reg_0x00'h is set to 00'h and all configuration is set by control/strap pins. A write of 01'h to reg_0x00'h will enable/allow configuration by registers; this will override the control/strap pins. Multiple devices may share the serial control bus since multiple addresses are supported. See [Figure 30](#).

The serial bus is comprised of three pins. The SCL is a Serial Bus Clock Input. The SDA is the Serial Bus Data Input / Output signal. Both SCL and SDA signals require an external pull up resistor to V_{DDIO} . For most applications a 4.7 k Ω pull up resistor to 3.3V may be used. The resistor value may be adjusted for capacitive loading and data rate requirements. The signals are either pulled High, or driven Low.

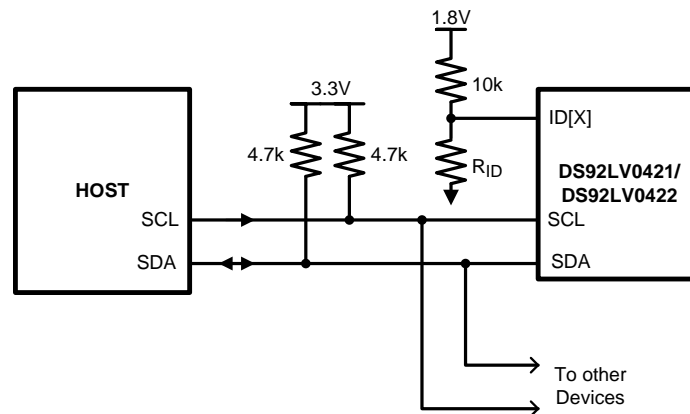

Figure 30. Serial Control Bus Connection

The third pin is the ID[X] pin. This pin sets one of five possible device addresses. Three different connections are possible. The pin may be tied to ground. The pin may be pulled to V_{DD} (1.8V, NOT V_{DDIO}) with a 10 k Ω resistor. Or a 10 k Ω pull up resistor (to V_{DD} 1.8V, NOT V_{DDIO}) and a pull down resistor of the recommended value to set other three possible addresses may be used. See [Table 10](#).

The Serial Bus protocol is controlled by START, START-Repeated, and STOP phases. A START occurs when SCL transitions Low while SDA is High. A STOP occurs when SDA transition High while SCL is also HIGH. See [Figure 31](#)

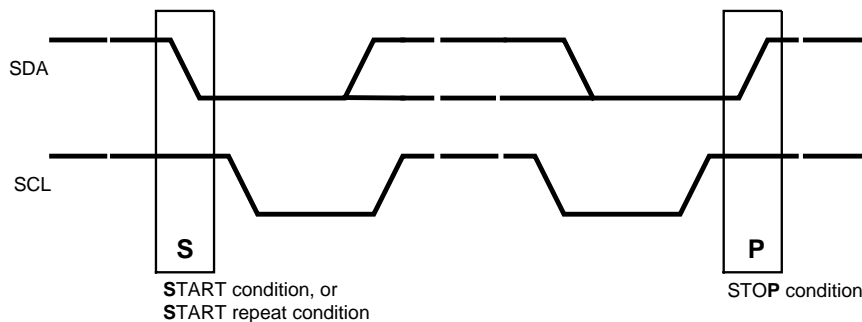

Figure 31. START and STOP Conditions

To communicate with a remote device, the host controller (master) sends the slave address and listens for a response from the slave. This response is referred to as an acknowledge bit (ACK). If a slave on the bus is addressed correctly, it Acknowledges (ACKs) the master by driving the SDA bus low. If the address doesn't match a device's slave address, it Not-acknowledges (NACKs) the master by letting SDA be pulled High. ACKs also occur on the bus when data is being transmitted. When the master is writing data, the slave ACKs after every data byte is successfully received. When the master is reading data, the master ACKs after every data byte is received to let the slave know it wants to receive another data byte. When the master wants to stop reading, it NACKs after the last data byte and creates a stop condition on the bus. All communication on the bus begins with either a Start condition or a Repeated Start condition. All communication on the bus ends with a Stop condition. A READ is shown in Figure 32 and a WRITE is shown in Figure 33.

If the Serial Bus is not required, the three pins may be left open (NC).

Table 10. ID[x] Resistor Value – DS92LV0421

Resistor RID kΩ	Address 7'b	Address 8'b 0 appended (WRITE)
0.47	7b' 110 1001 (h'69)	8b' 1101 0010 (h'D2)
2.7	7b' 110 1010 (h'6A)	8b' 1101 0100 (h'D4)
8.2	7b' 110 1011 (h'6B)	8b' 1101 0110 (h'D6)
Open	7b' 110 1110 (h'6E)	8b' 1101 1100 (h'DC)

Table 11. ID[x] Resistor Value – DS92LV0422

Resistor RID kΩ	Address 7'b	Address 8'b 0 appended (WRITE)
0.47	7b' 111 0001 (h'71)	8b' 1110 0010 (h'E2)
2.7	7b' 111 0010 (h'72)	8b' 1110 0100 (h'E4)
8.2	7b' 111 0011 (h'73)	8b' 1110 0110 (h'E6)
Open	7b' 111 0110 (h'76)	8b' 1110 1100 (h'EC)

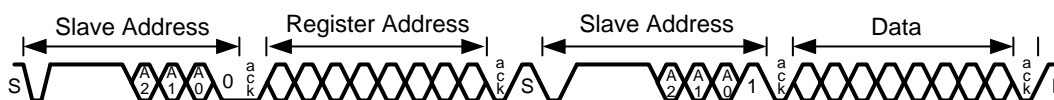

Figure 32. Serial Control Bus — READ



Figure 33. Serial Control Bus — WRITE

Table 12. DS92LV0421 SERIALIZER — Serial Bus Control Registers

ADD (dec)	ADD (hex)	Register Name	Bit(s)	R/W	Default (bin)	Function	Description
0	0	Ser Config 1	7	R/W	0	Reserved	Reserved
			6	R/W	0	MAPSEL	0: LSB on RxIN3 1: MSB on RxIN3
			5	R/W	0	Reserved	Reserved
			4	R/W	0	VODSEL	0: Low 1: High
			3:2	R/W	00	CONFIG	00: Control Signal Filter Disabled 01: Control Signal Filter Enabled 10: Reserved 11: Reserved
			1	R/W	0	SLEEP	Note – not the same function as PowerDown (PDB) 0: normal mode 1: Sleep Mode – Register settings retained.
			0	R/W	0	REG	0: Configurations set from control pins 1: Configuration set from registers (except I2C_ID)
1	1	Device ID	7	R/W	0	REG ID	0: Address from ID[X] Pin 1: Address from Register
			6:0	R/W	1101000	ID[X]	Serial Bus Device ID, IDs are: 7b '1101 001 (h'69) 7b '1101 010 (h'6A) 7b '1101 011 (h'6B) 7b '1101 110 (h'6E) All other addresses are Reserved .
2	2	De-Emphasis Control	7:5	R/W	000	De-E Setting	000: set by external Resistor 001: -1 dB 010: -2 dB 011: -3.3 dB 100: -5 dB 101: -6.7 dB 110: -9 dB 111: -12 dB
			4	R/W	0	De-E EN	0: De-Emphasis Enabled 1: De-Emphasis Disabled
			3:0	R/W	000	Reserved	Reserved

Table 13. DS92LV0422 DESERIALIZER — Serial Bus Control Registers

ADD (dec)	ADD (hex)	Register Name	Bit(s)	R/W	Default (bin)	Function	Description
0	0	Des Config 1	7	R/W	0	LFMODE	SSCG Mode — low frequency support 0: 20 to 65 MHz Operation 1: 10 to 20 MHz Operation
			6	R/W	0	MAPSEL	Channel Link Map Select 0: LSB on TxOUT3+/- 1: MSB on TxOUT3+/-
			5	R/W	0	Reserved	Reserved
			4	R/W	0	Reserved	Reserved
			3:2	R/W	00	CONFIG	00: Control Signal Filter Disabled 01: Control Signal Filter Enabled 10: Reserved 11: Reserved
			1	R/W	0	SLEEP	Note – not the same function as PowerDown (PDB) 0: normal mode 1: Sleep Mode – Register settings retained.
			0	R/W	0	REG Control	0: Configurations set from control pins 1: Configuration set from registers (except I2C_ID)
1	1	Device ID	7	R/W	0	REG ID	0: Address from ID[X] Pin 1: Address from Register
			6:0	R/W	1110000	ID[X]	Serial Bus Device ID, IDs are: 7b' 111 0001 (h'71) 7b' 111 0010 (h'72) 7b' 111 0011 (h'73) 7b' 111 0110 (h'76) All other addresses are Reserved .
2	2	Des Features 1	7	R/W	0	OEN	Output Enable Input See Table 5
			6	R/W	0	OSS_SEL	Output Sleep State Select See Table 5
			5:4	R/W	00	Reserved	Reserved
			3	R/W	0	VODSEL	LVDS Driver Output Voltage Select 0: LVDS VOD is ±250 mV, 500 mVp-p (typ) 1: LVDS VOD is ±400 mV, 800 mVp-p (typ)
			2:0	R/W	000	OSC_SEL	000: OFF 001: RESERVED 010: 25 MHz ±40% 011: 16.7 MHz ±40% 100: 12.5 MHz ±40% 101: 10 MHz ±40% 110: 8.3 MHz ±40% 111: 6.3MHz ±40%

Table 13. DS92LV0422 DESERIALIZER — Serial Bus Control Registers (continued)

ADD (dec)	ADD (hex)	Register Name	Bit(s)	R/W	Default (bin)	Function	Description
3	3	Des Features 2	7:5	R/W	000	EQ Gain	000: -1.625 dB 001: -3.25 dB 010: -4.87 dB 011: -6.5 dB 100: -8.125 dB 101: -9.75 dB 110: -11.375 dB 111: -13 dB
			4	R/W	0	EQ Enable	0: EQ = disabled 1: EQ = enabled
			3	R/W	0	Reserved	Reserved
			2:0	R/W	000	SSC	IF LFMODE = 0 then: 000: SSCG OFF 001: fdev = ±0.9%, fmod = CLK/2168 010: fdev = ±1.2%, fmod = CLK/2168 011: fdev = ±1.9%, fmod = CLK/2168 100: fdev = ±2.3%, fmod = CLK/2168 101: fdev = ±0.7%, fmod = CLK/21300 110: fdev = ±1.3%, fmod = CLK/1300 111: fdev = ±1.57%, fmod = CLK/1300 IF LFMODE = 1, then: 001: fdev = ±0.7%, fmod = CLK/625 010: fdev = ±1.3%, fmod = CLK/625 011: fdev = ±1.8%, fmod = CLK/625 100: fdev = ±2.2%, fmod = CLK/625 101: fdev = ±0.7%, fmod = CLK/385 110: fdev = ±1.2%, fmod = CLK/385 111: fdev = ±1.7%, fmod = CLK/385

Applications Information

DISPLAY APPLICATION

The DS92LV0421 and DS92LV0422 chipset is intended for interface between a host (graphics processor) and a Display. It supports an 24-bit color depth (RGB888) and up to 1024 X 768 display formats. In a RGB888 application, 24 color bits (R[7:0], G[7:0], B[7:0]), Pixel Clock (PCLK) and three control bits (VS, HS and DE) are supported across the serial link with PCLK rates from 10 to 75 MHz. The chipset may also be used in 18-bit color applications. In this application three to six general purpose signals may also be sent from host to display.

DS92LV0421 TYPICAL APPLICATION CONNECTION

Figure 34 shows a typical application of the DS92LV0421 for a 75 MHz 24-bit Color Display Application. The LVDS inputs require external 100 ohm differential termination resistors. The CML outputs require 0.1 µF AC coupling capacitors to the line. The line driver includes internal termination. Bypass capacitors are placed near the power supply pins. At a minimum, four 0.1 µF capacitors and a 4.7 µF capacitor should be used for local device bypassing. System GPO (General Purpose Output) signals control the PDB and BISTEN pins. The application assumes the companion deserializer (DS92LV0422) therefore the configuration pins are also both tied Low. In this example the cable is long, therefore the VODSEL pin is tied High and a De-Emphasis value is selected by the resistor R1. The interface to the host is with 1.8 V LVCMOS levels, thus the VDDIO pin is connected also to the 1.8V rail. The Optional Serial Bus Control is not used in this example, thus the SCL, SDA and ID[x] pins are left open. A delay cap is placed on the PDB signal to delay the enabling of the device until power is stable. Bypass capacitors are placed near the power supply pins. Ferrite beads are placed on the power lines for effective noise suppression.

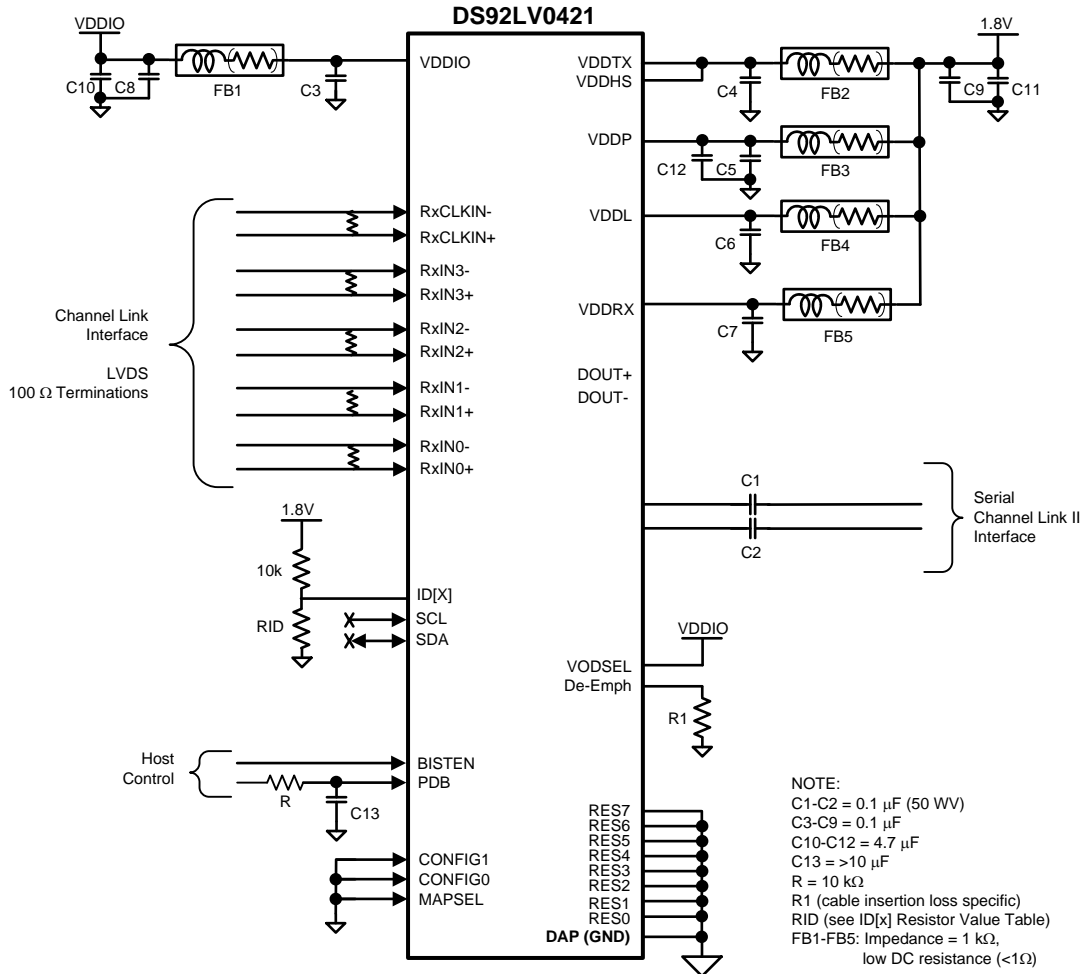

Figure 34. DS92LV0421 Typical Connection Diagram

DS92LV0422 TYPICAL APPLICATION CONNECTION

shows a typical application of the DS92LV0422 for a 75 MHz 24-bit Color Display Application. The CML inputs require 0.1 μ F AC coupling capacitors to the line. The line driver includes internal termination. Bypass capacitors are placed near the power supply pins. At a minimum, four 0.1 μ F capacitors and a 4.7 μ F capacitor should be used for local device bypassing. System GPO (General Purpose Output) signals control the PDB and BISTEN pins. The application assumes the companion deserializer (DS92LV0422) therefore the configuration pins are also both tied Low. The interface to the host is with 1.8 V LVCMOS levels, thus the VDDIO pin is connected also to the 1.8V rail. The Optional Serial Bus Control is not used in this example, thus the SCL, SDA and ID[x] pins are left open. A delay cap is placed on the PDB signal to delay the enabling of the device until power is stable. Bypass capacitors are placed near the power supply pins. Ferrite beads are placed on the power lines for effective noise suppression.

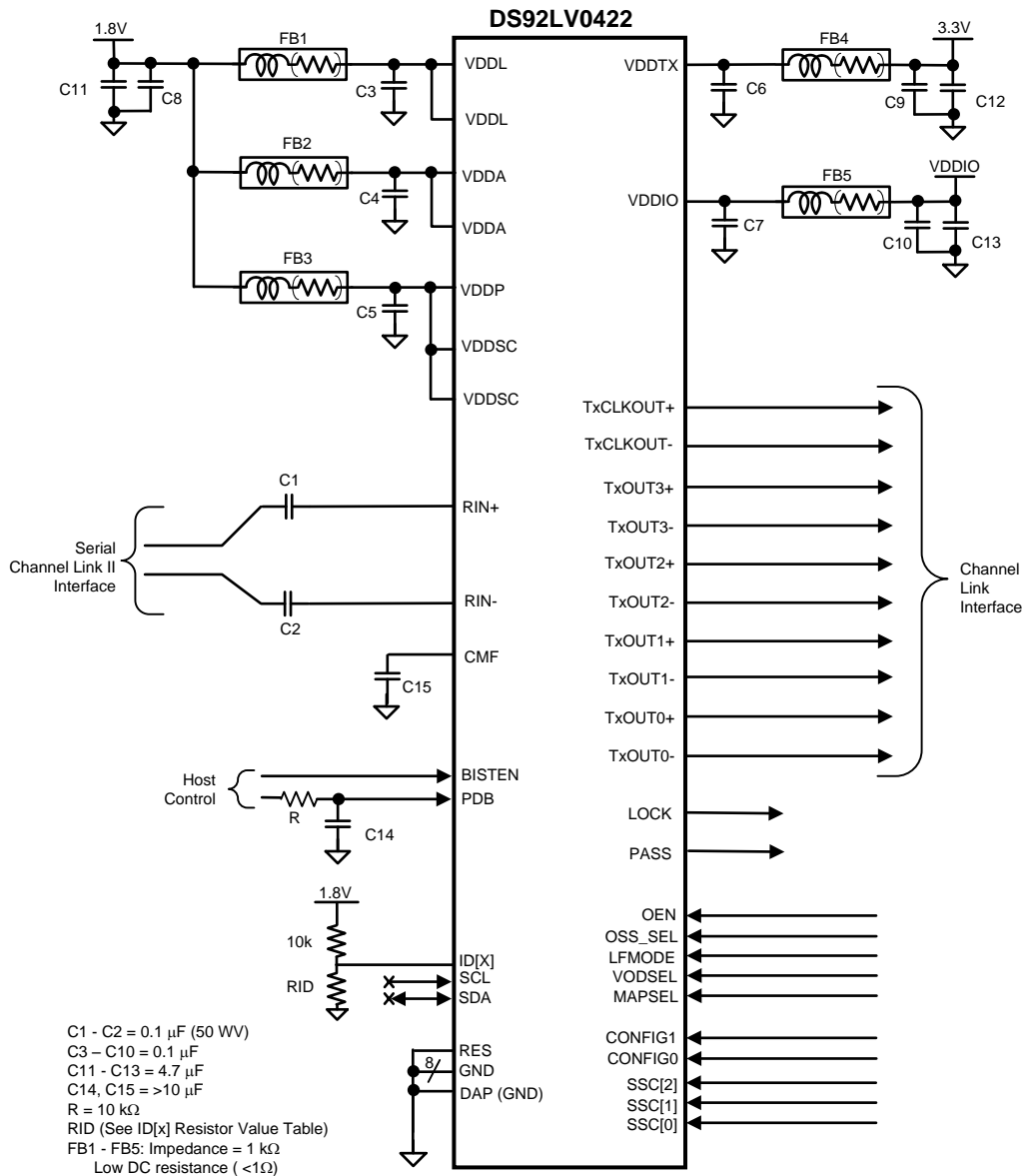

Figure 35. DS92LV0422 Typical Connection Diagram

Power Up Requirements and PDB Pin

The VDD (V_{DDn} and V_{DDIO}) supply ramp should be faster than 1.5 ms with a monotonic rise. If slower than 1.5 ms then a capacitor on the PDB pin is needed to ensure PDB arrives after all the VDD have settled to the recommended operating voltage. When PDB pin is pulled to V_{DDIO} , it is recommended to use a 10 k Ω pull-up and a 22 μ F cap to GND to delay the PDB input signal.

Transmission Media

The DS92LV0421 and the companion deserializer chipset is intended to be used in a point-to-point configuration, through a PCB trace, or through twisted pair cable. The DS92LV0421 provide internal terminations providing a clean signaling environment. The interconnect for LVDS should present a differential impedance of 100 Ohms. Use cables and connectors that have matched differential impedance to minimize impedance discontinuities. Shielded or un-shielded cables may be used depending upon the noise environment and application requirements.

Live Link Insertion

The serializer and deserializer devices support live link or cable hot plug applications. The automatic receiver lock to random data “plug & go” hot insertion capability allows the DS92LV0422 to attain lock to the active data stream during a live cable insertion event.

Alternate Color / Data Mapping

Color Mapped data Pin names are provided to specify a recommended mapping for 24-bit and 18-bit Applications. When connecting to earlier generations of Channel Link II deserializer devices, a color mapping review is recommended to ensure the correct connectivity is obtained. Table 14 provides examples for interfacing between DS92LV0421 and different deserializers.

Table 14. Serializer Alternate Color / Data Mapping

Channel Link	Bit Number	RGB (LSB Example)	DS92LV2422	DS90UR124	DS99R124Q	DS90C124
RxIN3	Bit 26	B1	B1	N/A		
	Bit 25	B0	B0			
	Bit 24	G1	G1			
	Bit 23	G0	G0			
	Bit 22	R1	R1			
	Bit 21	R0	R0			
RxIN2	Bit 20	DE	DE	ROUT20	TxOUT2	ROUT20
	Bit 19	VS	VS	ROUT19		ROUT19
	Bit 18	HS	HS	ROUT18		ROUT18
	Bit 17	B7	B7	ROUT17		ROUT17
	Bit 16	B6	B6ROUT10	ROUT16		ROUT16
	Bit 15	B5	B5	ROUT15		ROUT15
	Bit 14	B4	B4	ROUT14		ROUT14
RxIN1	Bit 13	B3	B3	ROUT13	TxOUT1	ROUT13
	Bit 12	B2	B2	ROUT12		ROUT12
	Bit 11	G7	G7	ROUT11		ROUT11
	Bit 10	G6	G6	ROUT10		ROUT10
	Bit 9	G5	G5	ROUT9		ROUT9
	Bit 8	G4	G4	ROUT8		ROUT8
	Bit 7	G3	G3	ROUT7		ROUT7
RxIN0	Bit 6	G2	G2	ROUT6	TxOUT0	ROUT6
	Bit 5	R7	R7	ROUT5		ROUT5
	Bit 4	R6	R6	ROUT4		ROUT4
	Bit 3	R5	R5	ROUT3		ROUT3
	Bit 2	R4	R4	ROUT2		ROUT2
	Bit 1	R3	R3	ROUT1		ROUT1
	Bit 0	R2	R2	ROUT0		ROUT0
N/A			N/A	ROUT23	OS2	ROUT23
				ROUT22	OS1	ROUT22
				ROUT21	OS0	ROUT21
DS92LV0421 Settings	MAPSEL = 0		CONFIG [1:0] = 00	CONFIG [1:0] = 10		CONFIG [1:0] = 11

Table 15. Deserializer Alternate Color / Data Mapping

Channel Link	Bit Number	RGB (LSB Example)	DS92LV2421	DS90UR241	DS99R421Q	DS90C241
TxOUT3	Bit 26	B1	B1	N/A		
	Bit 25	B0	B0			
	Bit 24	G1	G1			
	Bit 23	G0	G0			
	Bit 22	R1	R1			
	Bit 21	R0	R0			
TxOUT2	Bit 20	DE	DE	DIN20	RxIN2	DIN20
	Bit 19	VS	VS	DIN19		DIN19
	Bit 18	HS	HS	DIN18		DIN18
	Bit 17	B7	B7	DIN17		DIN17
	Bit 16	B6	B6ROUT10	DIN16		DIN16
	Bit 15	B5	B5	DIN15		DIN15
	Bit 14	B4	B4	DIN14		DIN14
TxOUT1	Bit 13	B3	B3	DIN13	RxIN1	DIN13
	Bit 12	B2	B2	DIN12		DIN12
	Bit 11	G7	G7	DIN11		DIN11
	Bit 10	G6	G6	DIN10		DIN10
	Bit 9	G5	G5	DIN9		DIN9
	Bit 8	G4	G4	DIN8		DIN8
	Bit 7	G3	G3	DIN7		DIN7
TxOUT0	Bit 6	G2	G2	DIN6	RxIN0	DIN6
	Bit 5	R7	R7	DIN5		DIN5
	Bit 4	R6	R6	DIN4		DIN4
	Bit 3	R5	R5	DIN3		DIN3
	Bit 2	R4	R4	DIN2		DIN2
	Bit 1	R3	R3	DIN1		DIN1
	Bit 0	R2	R2	DIN0		DIN0
N/A			N/A	DIN923	OS2	DIN923
				DIN922	OS1	DIN922
				DIN921	OS0	DIN921
DS92LV0422 Settings	MAPSEL = 0		CONFIG [1:0] = 00	CONFIG [1:0] = 10		CONFIG [1:0] = 11

PCB LAYOUT AND POWER SYSTEM CONSIDERATIONS

Circuit board layout and stack-up for the LVDS devices should be designed to provide low-noise power feed to the device. Good layout practice will also separate high frequency or high-level inputs and outputs to minimize unwanted stray noise pickup, feedback and interference. Power system performance may be greatly improved by using thin dielectrics (2 to 4 mils) for power / ground sandwiches. This arrangement provides plane capacitance for the PCB power system with low-inductance parasitics, which has proven especially effective at high frequencies, and makes the value and placement of external bypass capacitors less critical. External bypass capacitors should include both RF ceramic and tantalum electrolytic types. RF capacitors may use values in the range of 0.01 uF to 0.1 uF. Tantalum capacitors may be in the 2.2 uF to 10 uF range. Voltage rating of the tantalum capacitors should be at least 5X the power supply voltage being used.

Surface mount capacitors are recommended due to their smaller parasitics. When using multiple capacitors per supply pin, locate the smaller value closer to the pin. A large bulk capacitor is recommended at the point of power entry. This is typically in the 50uF to 100uF range and will smooth low frequency switching noise. It is recommended to connect power and ground pins directly to the power and ground planes with bypass capacitors connected to the plane with via on both ends of the capacitor. Connecting power or ground pins to an external bypass capacitor will increase the inductance of the path.

A small body size X7R chip capacitor, such as 0603, is recommended for external bypass. Its small body size reduces the parasitic inductance of the capacitor. The user must pay attention to the resonance frequency of these external bypass capacitors, usually in the range of 20-30 MHz. To provide effective bypassing, multiple capacitors are often used to achieve low impedance between the supply rails over the frequency of interest. At high frequency, it is also a common practice to use two vias from power and ground pins to the planes, reducing the impedance at high frequency.

Some devices provide separate power and ground pins for different portions of the circuit. This is done to isolate switching noise effects between different sections of the circuit. Separate planes on the PCB are typically not required. Pin Description tables typically provide guidance on which circuit blocks are connected to which power pin pairs. In some cases, an external filter may be used to provide clean power to sensitive circuits such as PLLs.

Use at least a four layer board with a power and ground plane. Locate LVCMOS signals away from the LVDS lines to prevent coupling from the LVCMOS lines to the LVDS lines. Closely-coupled differential lines of 100 Ohms are typically recommended for LVDS interconnect. The closely coupled lines help to ensure that coupled noise will appear as common-mode and thus is rejected by the receivers. The tightly coupled lines will also radiate less.

Information on the WQFN style package is provided in Texas Instruments Application Note: AN-1187([SNOA401](#)).

LVDS INTERCONNECT GUIDELINES

See AN-1108([SNLA008](#)) and AN-905([SNLA035](#)) for full details.

- Use 100Ω coupled differential pairs
- Use the S/2S/3S rule in spacings
 - S = space between the pair
 - 2S = space between pairs
 - 3S = space to LVCMOS signal
- Minimize the number of Vias
- Use differential connectors when operating above 500Mbps line speed
- Maintain balance of the traces
- Minimize skew within the pair
- Terminate as close to the TX outputs and RX inputs as possible

REVISION HISTORY

Changes from Revision B (April 2013) to Revision C	Page
• Changed layout of National Data Sheet to TI format	40

PACKAGING INFORMATION

Orderable Device	Status (1)	Package Type	Package Drawing	Pins	Package Qty	Eco Plan (2)	Lead/Ball Finish	MSL Peak Temp (3)	Op Temp (°C)	Top-Side Markings (4)	Samples
DS92LV0421SQ/NOPB	ACTIVE	WQFN	NJK	36	1000	Green (RoHS & no Sb/Br)	CU SN	Level-3-260C-168 HR	-40 to 85	LV0421	Samples
DS92LV0421SQE/NOPB	ACTIVE	WQFN	NJK	36	250	Green (RoHS & no Sb/Br)	CU SN	Level-3-260C-168 HR	-40 to 85	LV0421	Samples
DS92LV0421SQX/NOPB	ACTIVE	WQFN	NJK	36	2500	Green (RoHS & no Sb/Br)	CU SN	Level-3-260C-168 HR	-40 to 85	LV0421	Samples
DS92LV0422SQ/NOPB	ACTIVE	WQFN	RHS	48	1000	Green (RoHS & no Sb/Br)	CU SN	Level-3-260C-168 HR	-40 to 85	LV0422	Samples
DS92LV0422SQE/NOPB	ACTIVE	WQFN	RHS	48	250	Green (RoHS & no Sb/Br)	CU SN	Level-3-260C-168 HR	-40 to 85	LV0422	Samples
DS92LV0422SQX/NOPB	ACTIVE	WQFN	RHS	48	2500	Green (RoHS & no Sb/Br)	CU SN	Level-3-260C-168 HR	-40 to 85	LV0422	Samples

(1) The marketing status values are defined as follows:

ACTIVE: Product device recommended for new designs.

LIFEBUY: TI has announced that the device will be discontinued, and a lifetime-buy period is in effect.

NRND: Not recommended for new designs. Device is in production to support existing customers, but TI does not recommend using this part in a new design.

PREVIEW: Device has been announced but is not in production. Samples may or may not be available.

OBSELETE: TI has discontinued the production of the device.

(2) Eco Plan - The planned eco-friendly classification: Pb-Free (RoHS), Pb-Free (RoHS Exempt), or Green (RoHS & no Sb/Br) - please check <http://www.ti.com/productcontent> for the latest availability information and additional product content details.

TBD: The Pb-Free/Green conversion plan has not been defined.

Pb-Free (RoHS): TI's terms "Lead-Free" or "Pb-Free" mean semiconductor products that are compatible with the current RoHS requirements for all 6 substances, including the requirement that lead not exceed 0.1% by weight in homogeneous materials. Where designed to be soldered at high temperatures, TI Pb-Free products are suitable for use in specified lead-free processes.

Pb-Free (RoHS Exempt): This component has a RoHS exemption for either 1) lead-based flip-chip solder bumps used between the die and package, or 2) lead-based die adhesive used between the die and leadframe. The component is otherwise considered Pb-Free (RoHS compatible) as defined above.

Green (RoHS & no Sb/Br): TI defines "Green" to mean Pb-Free (RoHS compatible), and free of Bromine (Br) and Antimony (Sb) based flame retardants (Br or Sb do not exceed 0.1% by weight in homogeneous material)

(3) MSL, Peak Temp. -- The Moisture Sensitivity Level rating according to the JEDEC industry standard classifications, and peak solder temperature.

(4) Multiple Top-Side Markings will be inside parentheses. Only one Top-Side Marking contained in parentheses and separated by a "~" will appear on a device. If a line is indented then it is a continuation of the previous line and the two combined represent the entire Top-Side Marking for that device.

Important Information and Disclaimer:The information provided on this page represents TI's knowledge and belief as of the date that it is provided. TI bases its knowledge and belief on information provided by third parties, and makes no representation or warranty as to the accuracy of such information. Efforts are underway to better integrate information from third parties. TI has taken and continues to take reasonable steps to provide representative and accurate information but may not have conducted destructive testing or chemical analysis on incoming materials and chemicals. TI and TI suppliers consider certain information to be proprietary, and thus CAS numbers and other limited information may not be available for release.

In no event shall TI's liability arising out of such information exceed the total purchase price of the TI part(s) at issue in this document sold by TI to Customer on an annual basis.

TAPE AND REEL INFORMATION



QUADRANT ASSIGNMENTS FOR PIN 1 ORIENTATION IN TAPE



*All dimensions are nominal

Device	Package Type	Package Drawing	Pins	SPQ	Reel Diameter (mm)	Reel Width W1 (mm)	A0 (mm)	B0 (mm)	K0 (mm)	P1 (mm)	W (mm)	Pin1 Quadrant
DS92LV0421SQ/NOPB	WQFN	NJK	36	1000	330.0	16.4	6.3	6.3	1.5	12.0	16.0	Q1
DS92LV0421SQE/NOPB	WQFN	NJK	36	250	178.0	16.4	6.3	6.3	1.5	12.0	16.0	Q1
DS92LV0421SQX/NOPB	WQFN	NJK	36	2500	330.0	16.4	6.3	6.3	1.5	12.0	16.0	Q1
DS92LV0422SQ/NOPB	WQFN	RHS	48	1000	330.0	16.4	7.3	7.3	1.3	12.0	16.0	Q1
DS92LV0422SQE/NOPB	WQFN	RHS	48	250	178.0	16.4	7.3	7.3	1.3	12.0	16.0	Q1
DS92LV0422SQX/NOPB	WQFN	RHS	48	2500	330.0	16.4	7.3	7.3	1.3	12.0	16.0	Q1

TAPE AND REEL BOX DIMENSIONS

*All dimensions are nominal

Device	Package Type	Package Drawing	Pins	SPQ	Length (mm)	Width (mm)	Height (mm)
DS92LV0421SQ/NOPB	WQFN	NJK	36	1000	367.0	367.0	38.0
DS92LV0421SQE/NOPB	WQFN	NJK	36	250	213.0	191.0	55.0
DS92LV0421SQX/NOPB	WQFN	NJK	36	2500	367.0	367.0	38.0
DS92LV0422SQ/NOPB	WQFN	RHS	48	1000	367.0	367.0	38.0
DS92LV0422SQE/NOPB	WQFN	RHS	48	250	213.0	191.0	55.0
DS92LV0422SQX/NOPB	WQFN	RHS	48	2500	367.0	367.0	38.0

THERMAL PAD MECHANICAL DATA

RHS (S-PWQFN-N48)

PLASTIC QUAD FLATPACK NO-LEAD

THERMAL INFORMATION

This package incorporates an exposed thermal pad that is designed to be attached directly to an external heatsink. The thermal pad must be soldered directly to the printed circuit board (PCB). After soldering, the PCB can be used as a heatsink. In addition, through the use of thermal vias, the thermal pad can be attached directly to the appropriate copper plane shown in the electrical schematic for the device, or alternatively, can be attached to a special heatsink structure designed into the PCB. This design optimizes the heat transfer from the integrated circuit (IC).

For information on the Quad Flatpack No-Lead (QFN) package and its advantages, refer to Application Report, QFN/SON PCB Attachment, Texas Instruments Literature No. SLUA271. This document is available at www.ti.com.

The exposed thermal pad dimensions for this package are shown in the following illustration.

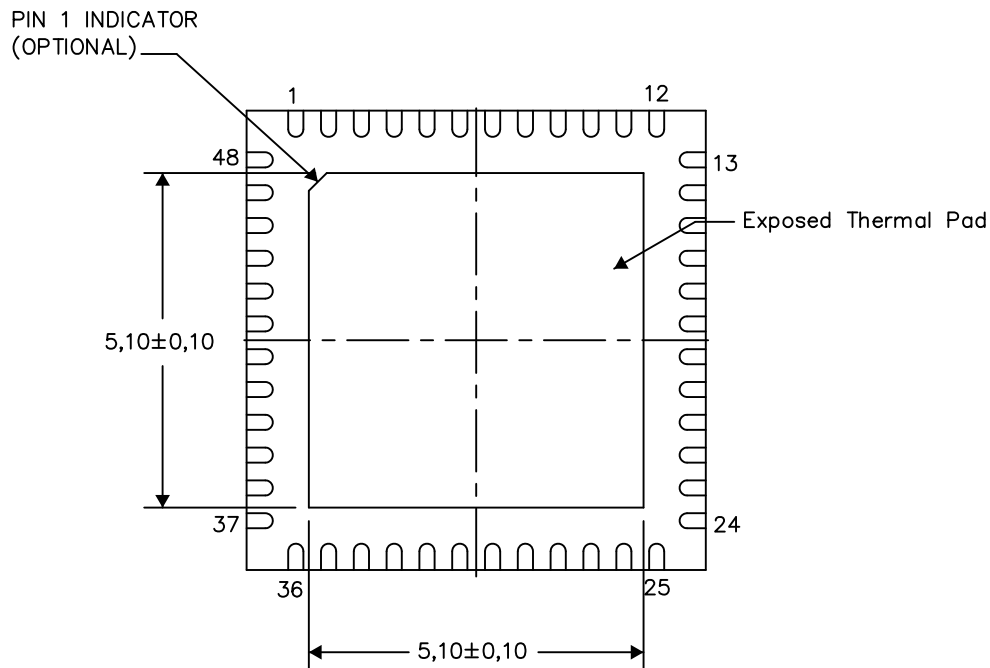

Bottom View

Exposed Thermal Pad Dimensions

4221096-2/B 03/14

NOTE: All linear dimensions are in millimeters

NJK0036A

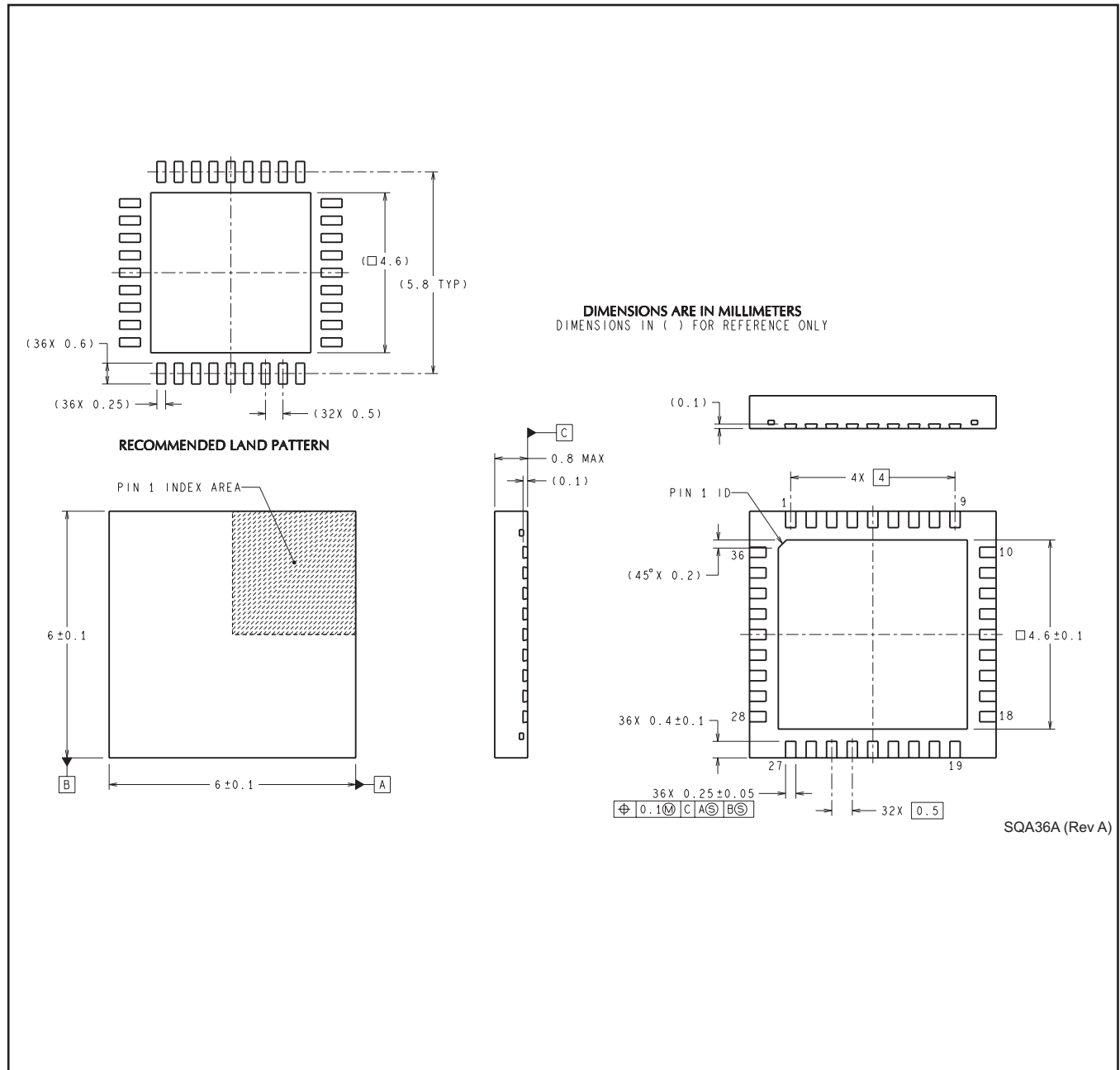

IMPORTANT NOTICE

Texas Instruments Incorporated and its subsidiaries (TI) reserve the right to make corrections, enhancements, improvements and other changes to its semiconductor products and services per JESD46, latest issue, and to discontinue any product or service per JESD48, latest issue. Buyers should obtain the latest relevant information before placing orders and should verify that such information is current and complete. All semiconductor products (also referred to herein as "components") are sold subject to TI's terms and conditions of sale supplied at the time of order acknowledgment.

TI warrants performance of its components to the specifications applicable at the time of sale, in accordance with the warranty in TI's terms and conditions of sale of semiconductor products. Testing and other quality control techniques are used to the extent TI deems necessary to support this warranty. Except where mandated by applicable law, testing of all parameters of each component is not necessarily performed.

TI assumes no liability for applications assistance or the design of Buyers' products. Buyers are responsible for their products and applications using TI components. To minimize the risks associated with Buyers' products and applications, Buyers should provide adequate design and operating safeguards.

TI does not warrant or represent that any license, either express or implied, is granted under any patent right, copyright, mask work right, or other intellectual property right relating to any combination, machine, or process in which TI components or services are used. Information published by TI regarding third-party products or services does not constitute a license to use such products or services or a warranty or endorsement thereof. Use of such information may require a license from a third party under the patents or other intellectual property of the third party, or a license from TI under the patents or other intellectual property of TI.

Reproduction of significant portions of TI information in TI data books or data sheets is permissible only if reproduction is without alteration and is accompanied by all associated warranties, conditions, limitations, and notices. TI is not responsible or liable for such altered documentation. Information of third parties may be subject to additional restrictions.

Resale of TI components or services with statements different from or beyond the parameters stated by TI for that component or service voids all express and any implied warranties for the associated TI component or service and is an unfair and deceptive business practice. TI is not responsible or liable for any such statements.

Buyer acknowledges and agrees that it is solely responsible for compliance with all legal, regulatory and safety-related requirements concerning its products, and any use of TI components in its applications, notwithstanding any applications-related information or support that may be provided by TI. Buyer represents and agrees that it has all the necessary expertise to create and implement safeguards which anticipate dangerous consequences of failures, monitor failures and their consequences, lessen the likelihood of failures that might cause harm and take appropriate remedial actions. Buyer will fully indemnify TI and its representatives against any damages arising out of the use of any TI components in safety-critical applications.

In some cases, TI components may be promoted specifically to facilitate safety-related applications. With such components, TI's goal is to help enable customers to design and create their own end-product solutions that meet applicable functional safety standards and requirements. Nonetheless, such components are subject to these terms.

No TI components are authorized for use in FDA Class III (or similar life-critical medical equipment) unless authorized officers of the parties have executed a special agreement specifically governing such use.

Only those TI components which TI has specifically designated as military grade or "enhanced plastic" are designed and intended for use in military/aerospace applications or environments. Buyer acknowledges and agrees that any military or aerospace use of TI components which have **not** been so designated is solely at the Buyer's risk, and that Buyer is solely responsible for compliance with all legal and regulatory requirements in connection with such use.

TI has specifically designated certain components as meeting ISO/TS16949 requirements, mainly for automotive use. In any case of use of non-designated products, TI will not be responsible for any failure to meet ISO/TS16949.

Products

Audio	www.ti.com/audio
Amplifiers	amplifier.ti.com
Data Converters	dataconverter.ti.com
DLP® Products	www.dlp.com
DSP	dsp.ti.com
Clocks and Timers	www.ti.com/clocks
Interface	interface.ti.com
Logic	logic.ti.com
Power Mgmt	power.ti.com
Microcontrollers	microcontroller.ti.com
RFID	www.ti-rfid.com
OMAP Applications Processors	www.ti.com/omap
Wireless Connectivity	www.ti.com/wirelessconnectivity

Applications

Automotive and Transportation	www.ti.com/automotive
Communications and Telecom	www.ti.com/communications
Computers and Peripherals	www.ti.com/computers
Consumer Electronics	www.ti.com/consumer-apps
Energy and Lighting	www.ti.com/energy
Industrial	www.ti.com/industrial
Medical	www.ti.com/medical
Security	www.ti.com/security
Space, Avionics and Defense	www.ti.com/space-avionics-defense
Video and Imaging	www.ti.com/video

TI E2E Community

e2e.ti.com