



FDG6331L

# FDG6331L

## Integrated Load Switch

### General Description

This device is particularly suited for compact power management in portable electronic equipment where 2.5V to 8V input and 0.8A output current capability are needed. This load switch integrates a small N-Channel power MOSFET (Q1) that drives a large P-Channel power MOSFET (Q2) in one tiny SC70-6 package.

### Applications

- Power management
- Load switch

### Features

- -0.8 A, -8 V.  $R_{DS(ON)} = 260\text{ m}\Omega @ V_{GS} = -4.5\text{ V}$   
 $R_{DS(ON)} = 330\text{ m}\Omega @ V_{GS} = -2.5\text{ V}$   
 $R_{DS(ON)} = 450\text{ m}\Omega @ V_{GS} = -1.8\text{ V}$
- Control MOSFET (Q1) includes Zener protection for ESD ruggedness (>6KV Human body model)
- High performance trench technology for extremely low  $R_{DS(ON)}$
- Compact industry standard SC70-6 surface mount package

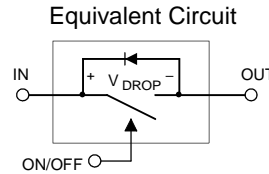
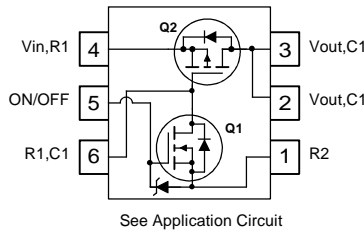
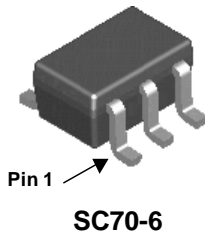

### Absolute Maximum Ratings T<sub>A</sub>=25°C unless otherwise noted

Symbol	Parameter	Ratings	Units
V <sub>IN</sub>	Gate-Source Voltage (Q2)	± 8	V
V <sub>ON/OFF</sub>	Gate-Source Voltage (Q1)	-0.5 to 8	V
I <sub>Load</sub>	Load Current – Continuous (Note 2)	0.8	A
	– Pulsed (Note 2)	2.4	
P <sub>D</sub>	Maximum Power Dissipation (Note 1)	0.3	W
T <sub>J</sub> , T <sub>STG</sub>	Operating and Storage Junction Temperature Range	-55 to +150	°C

### Thermal Characteristics

R <sub>θJA</sub>	Thermal Resistance, Junction-to-Ambient (Note 1a)	415	°C/W
------------------	---	-----	------

### Package Marking and Ordering Information

Device Marking	Device	Reel Size	Tape width	Quantity
.31	FDG6331L	7"	8mm	3000 units

**Electrical Characteristics** $T_A = 25^\circ\text{C}$  unless otherwise noted

Symbol	Parameter	Test Conditions	Min	Typ	Max	Units
<b>Off Characteristics</b>						
$BV_{IN}$	Vin Breakdown Voltage	$V_{ON/OFF} = 0\text{ V}, I_D = -250\ \mu\text{A}$	8			V
$I_{Load}$	Zero Gate Voltage Drain Current	$V_{IN} = -6.4\text{ V}, V_{ON/OFF} = 0\text{ V}$			-1	$\mu\text{A}$
$I_{FL}$	Leakage Current, Forward	$V_{ON/OFF} = 0\text{ V}, V_{IN} = 8\text{ V}$			100	nA
$I_{RL}$	Leakage Current, Reverse	$V_{ON/OFF} = 0\text{ V}, V_{IN} = -8\text{ V}$			-100	nA
<b>On Characteristics (Note 2)</b>						
$V_{ON/OFF(th)}$	Gate Threshold Voltage	$V_{IN} = V_{ON/OFF}, I_D = -250\ \mu\text{A}$	0.4	0.9	1.5	V
$R_{DS(on)}$	Static Drain-Source On-Resistance (Q2)	$V_{IN} = 4.5\text{ V}, I_D = -0.8\text{ A}$		155	260	$\text{m}\Omega$
		$V_{IN} = 2.5\text{ V}, I_D = -0.7\text{ A}$		193	330	
		$V_{IN} = 1.8\text{ V}, I_D = -0.6\text{ A}$		248	450	
$R_{DS(on)}$	Static Drain-Source On-Resistance (Q1)	$V_{IN} = 4.5\text{ V}, I_D = 0.4\text{ A}$		310	400	$\text{m}\Omega$
		$V_{IN} = 2.7\text{ V}, I_D = 0.2\text{ A}$		380	500	
<b>Drain-Source Diode Characteristics and Maximum Ratings</b>						
$I_S$	Maximum Continuous Drain-Source Diode Forward Current				-0.25	A
$V_{SD}$	Drain-Source Diode Forward Voltage	$V_{ON/OFF} = 0\text{ V}, I_S = -0.25\text{ A (Note 2)}$			-1.2	V

**Notes:**

- $R_{\theta JA}$  is the sum of the junction-to-case and case-to-ambient thermal resistance where the case thermal reference is defined as the solder mounting surface of the drain pins.  $R_{\theta JC}$  is guaranteed by design while  $R_{\theta JA}$  is determined by the user's board design.
- Pulse Test: Pulse Width < 300 $\mu\text{s}$ , Duty Cycle < 2.0%.

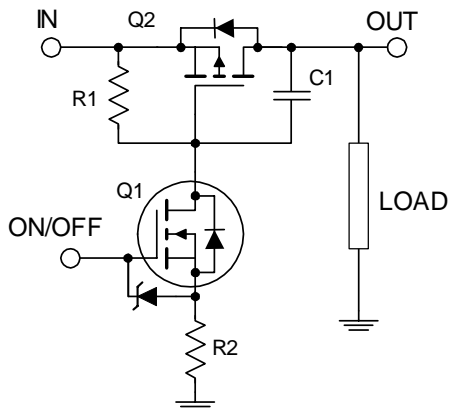
**FDG6331L Load Switch Application Circuit****External Component Recommendation:**

For additional in-rush current control, R2 and C1 can be added. For more information, see application note AN1030.

Typical Characteristics

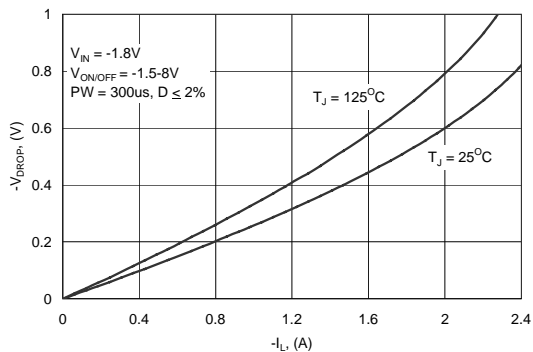

Figure 1. Conduction Voltage Drop Variation with Load Current.

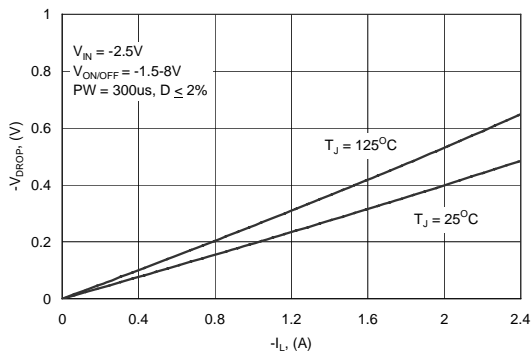

Figure 2. Conduction Voltage Drop Variation with Load Current.

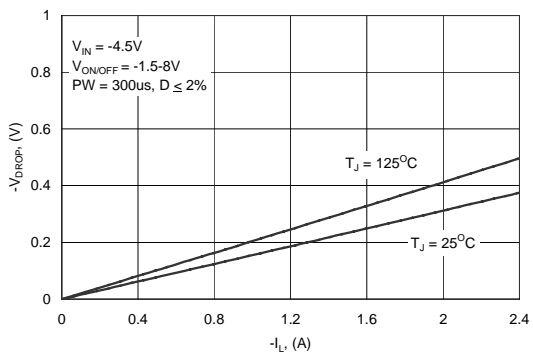

Figure 3. Conduction Voltage Drop Variation with Load Current.

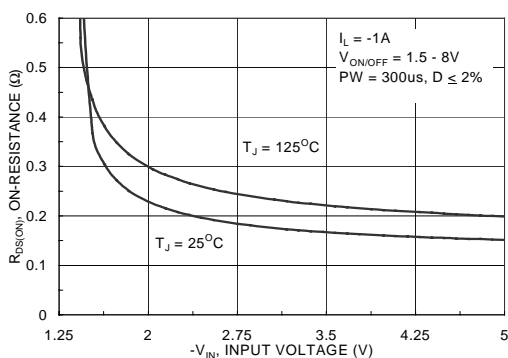
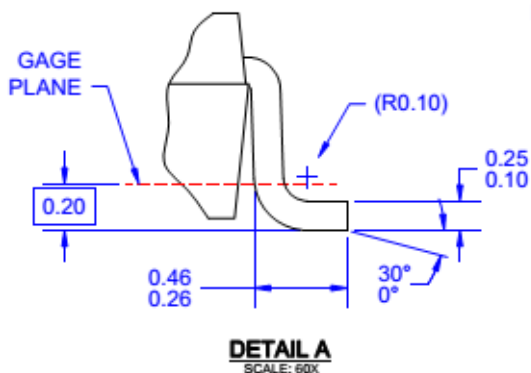
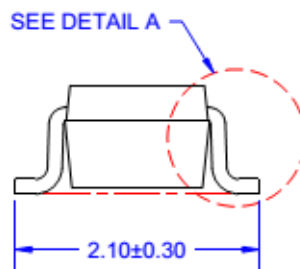
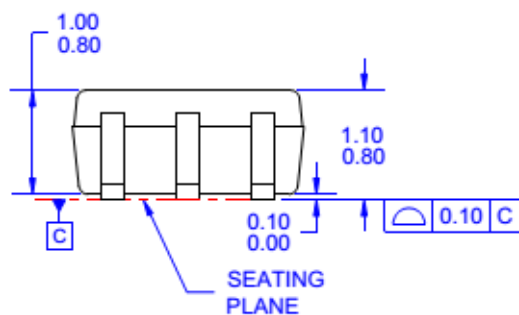
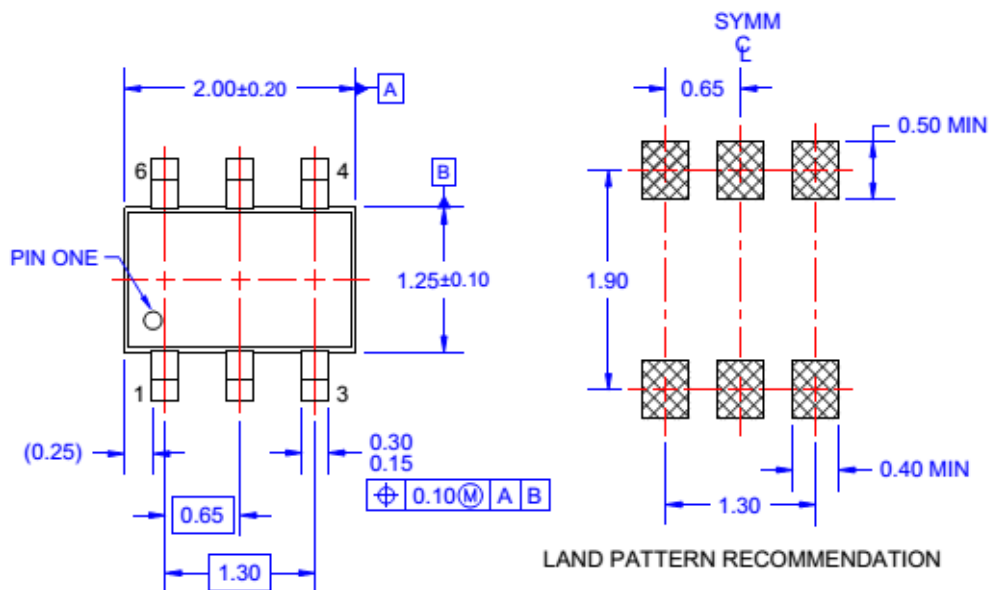

Figure 4. On-Resistance Variation With Input Voltage

## Dimensional Outline and Pad Layout



### NOTES: UNLESS OTHERWISE SPECIFIED

- A) THIS PACKAGE CONFORMS TO EIAJ SC-88, 1996.
- B) ALL DIMENSIONS ARE IN MILLIMETERS.
- C) DIMENSIONS DO NOT INCLUDE BURRS OR MOLD FLASH.
- D) DRAWING FILENAME: MKT-MAA06AREV6

Package drawings are provided as a service to customers considering Fairchild components. Drawings may change in any manner without notice. Please note the revision and/or date on the drawing and contact a Fairchild Semiconductor representative to verify or obtain the most recent revision. Package specifications do not expand the terms of Fairchild's worldwide terms and conditions, specifically the warranty therein, which covers Fairchild products.

Always visit Fairchild Semiconductor's online packaging area for the most recent package drawings:  
[https://www.fairchildsemi.com/evaluate/package-specifications/packageDetails.html?id=PN\\_NSC70-006](https://www.fairchildsemi.com/evaluate/package-specifications/packageDetails.html?id=PN_NSC70-006)



**TRADEMARKS**

The following includes registered and unregistered trademarks and service marks, owned by Fairchild Semiconductor and/or its global subsidiaries, and is not intended to be an exhaustive list of all such trademarks.

- |                          |   |                                       |                  |
|--------------------------|---|---------------------------------------|------------------|
| AccuPower™               | F-PFET™   | OPTOPLANAR®                           |                  |
| Awinda®                  | FRFET®  |                                       | TinyBoost®       |
| AX-CAP®*                 | Global Power Resource™                          | PowerTrench®                          | TinyBuck®        |
| BitSiC™                  | GreenBridge™                                    | PowerXST™                             | TinyCalc™        |
| Build it Now™            | Green FPS™                                      | Programmable Active Droop™            | TinyLogic®       |
| CorePLUS™                | Green FPS™ e-Series™                            | QFET®                                 | TINYOPTO™        |
| CorePOWER™               | Gmax™   | QS™                                   | TinyPower™       |
| CROSSVOLT™               | GTO™  | Quiet Series™                         | TinyPWM™         |
| CTL™                     | IntelliMAX™                                     | RapidConfigure™                       | TinyWire™        |
| Current Transfer Logic™  | ISOPANAR™                                       |                                       | TranSiC™         |
| DEUXPEED®                | Marking Small Speakers Sound Louder and Better™ | Saving our world, 1mW/W/kW at a time™ | TriFault Detect™ |
| Dual Cool™               | MegaBuck™                                       | SignalWise™                           | TRUECURRENT®*    |
| EcoSPARK®                | MICROCOUPLER™                                   | SmartMax™                             | μSerDes™         |
| EfficientMax™            | MicroFET™                                       | SMART START™                          |                  |
| ESBC™                    | MicroPak™                                       | Solutions for Your Success™           | UHC®             |
|                          | MicroPak2™                                      | SPM®                                  | Ultra FRFET™     |
| Fairchild®               | MillerDrive™                                    | STEALTH™                              | UniFET™          |
| Fairchild Semiconductor® | MotionMax™                                      | SuperFET®                             | VCX™             |
| FACT Quiet Series™       | MotionGrid®                                     | SuperSOT™-3                           | VisualMax™       |
| FACT®                    | MTi®  | SuperSOT™-6                           | VoltagePlus™     |
| FAST®                    | MTx®  | SuperSOT™-8                           | XST™             |
| FastvCore™               | MVN®  | SupreMOS®                             | Xsens™           |
| FETBench™                | mWSaver®  | SyncFET™                              | 仙童™              |
| FPS™                     | OptoHiT™  | Sync-Lock™                            |                  |
|                          | OPTOLOGIC®                                      |                                       |                  |

\*Trademarks of System General Corporation, used under license by Fairchild Semiconductor.

**DISCLAIMER**

FAIRCHILD SEMICONDUCTOR RESERVES THE RIGHT TO MAKE CHANGES WITHOUT FURTHER NOTICE TO ANY PRODUCTS HEREIN TO IMPROVE RELIABILITY, FUNCTION, OR DESIGN. TO OBTAIN THE LATEST, MOST UP-TO-DATE DATASHEET AND PRODUCT INFORMATION, VISIT OUR WEBSITE AT [HTTP://WWW.FAIRCHILDSEMI.COM](http://www.fairchildsemi.com). FAIRCHILD DOES NOT ASSUME ANY LIABILITY ARISING OUT OF THE APPLICATION OR USE OF ANY PRODUCT OR CIRCUIT DESCRIBED HEREIN; NEITHER DOES IT CONVEY ANY LICENSE UNDER ITS PATENT RIGHTS, NOR THE RIGHTS OF OTHERS. THESE SPECIFICATIONS DO NOT EXPAND THE TERMS OF FAIRCHILD'S WORLDWIDE TERMS AND CONDITIONS, SPECIFICALLY THE WARRANTY THEREIN, WHICH COVERS THESE PRODUCTS.

**LIFE SUPPORT POLICY**

FAIRCHILD'S PRODUCTS ARE NOT AUTHORIZED FOR USE AS CRITICAL COMPONENTS IN LIFE SUPPORT DEVICES OR SYSTEMS WITHOUT THE EXPRESS WRITTEN APPROVAL OF FAIRCHILD SEMICONDUCTOR CORPORATION.

As used here in:

- Life support devices or systems are devices or systems which, (a) are intended for surgical implant into the body or (b) support or sustain life, and (c) whose failure to perform when properly used in accordance with instructions for use provided in the labeling, can be reasonably expected to result in a significant injury of the user.
- A critical component in any component of a life support, device, or system whose failure to perform can be reasonably expected to cause the failure of the life support device or system, or to affect its safety or effectiveness.

**ANTI-COUNTERFEITING POLICY**

Fairchild Semiconductor Corporation's Anti-Counterfeiting Policy. Fairchild's Anti-Counterfeiting Policy is also stated on our external website, [www.fairchildsemi.com](http://www.fairchildsemi.com), under Sales Support.

Counterfeiting of semiconductor parts is a growing problem in the industry. All manufactures of semiconductor products are experiencing counterfeiting of their parts. Customers who inadvertently purchase counterfeit parts experience many problems such as loss of brand reputation, substandard performance, failed application, and increased cost of production and manufacturing delays. Fairchild is taking strong measures to protect ourselves and our customers from the proliferation of counterfeit parts. Fairchild strongly encourages customers to purchase Fairchild parts either directly from Fairchild or from Authorized Fairchild Distributors who are listed by country on our web page cited above. Products customers buy either from Fairchild directly or from Authorized Fairchild Distributors are genuine parts, have full traceability, meet Fairchild's quality standards for handling and storage and provide access to Fairchild's full range of up-to-date technical and product information. Fairchild and our Authorized Distributors will stand behind all warranties and will appropriately address and warranty issues that may arise. Fairchild will not provide any warranty coverage or other assistance for parts bought from Unauthorized Sources. Fairchild is committed to combat this global problem and encourage our customers to do their part in stopping this practice by buying direct or from authorized distributors.

**PRODUCT STATUS DEFINITIONS**

**Definition of Terms**

Datasheet Identification	Product Status	Definition
Advance Information	Formative / In Design	Datasheet contains the design specifications for product development. Specifications may change in any manner without notice.
Preliminary	First Production	Datasheet contains preliminary data; supplementary data will be published at a later date. Fairchild Semiconductor reserves the right to make changes at any time without notice to improve design.
No Identification Needed	Full Production	Datasheet contains final specifications. Fairchild Semiconductor reserves the right to make changes at any time without notice to improve the design.
Obsolete	Not In Production	Datasheet contains specifications on a product that is discontinued by Fairchild Semiconductor. The datasheet is for reference information only.