

| COUNT | DESCRIPTION OF REVISIONS | BY | CHKD | DATE | COUNT | DESCRIPTION OF REVISIONS | BY | CHKD | DATE |
|-------|--------------------------|----|------|------|-------|--------------------------|----|------|------|
|       |                          |    |      |      |       |                          |    |      |      |
|       |                          |    |      |      |       |                          |    |      |      |
|       |                          |    |      |      |       |                          |    |      |      |

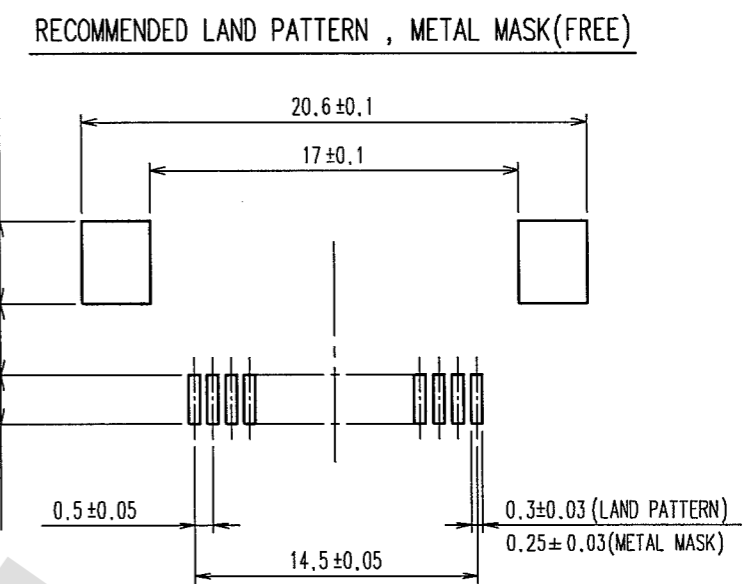

RECOMMENDED METAL MASK THICKNESS:  $t = 0.15$

- NOTE
- 1 REFERENCE IS A.
  - 2 LEAD CO-PLANARITY SHALL BE 0.1 MAX.
  - 3 THICKNESS OF SUPPORTING TAPE SHALL BE 0.188(7.5mil) MIN.

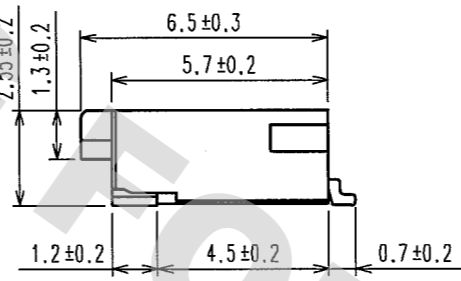
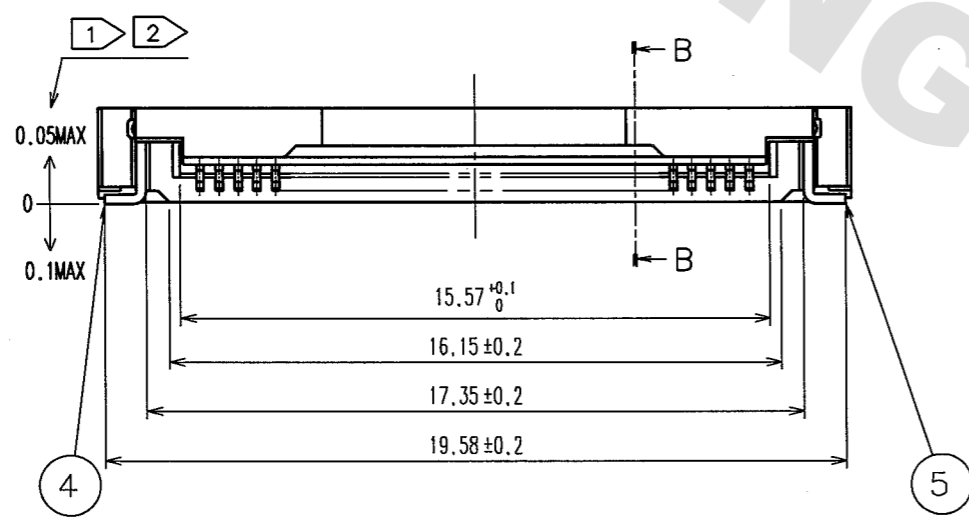
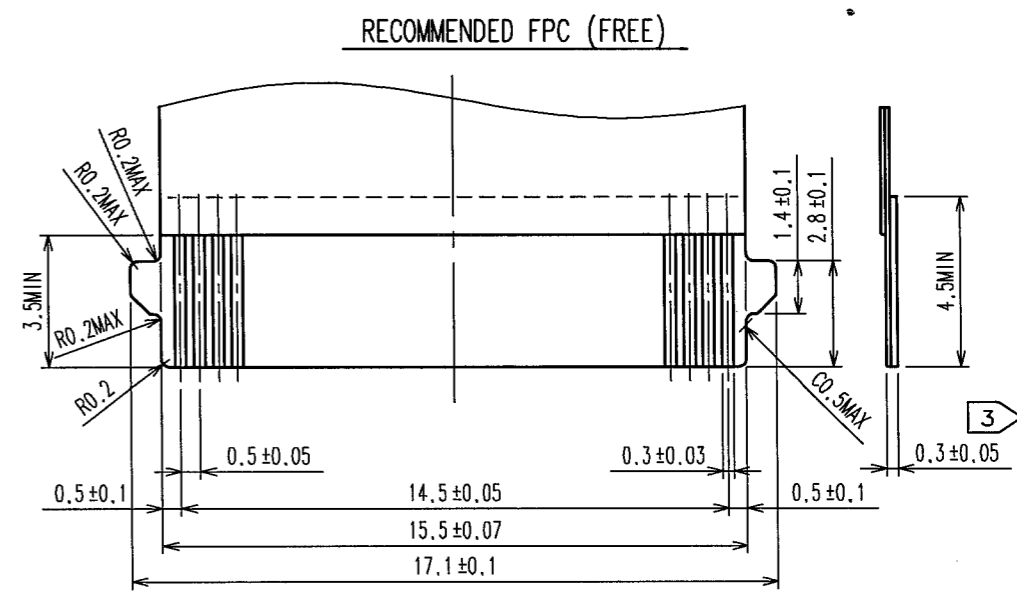
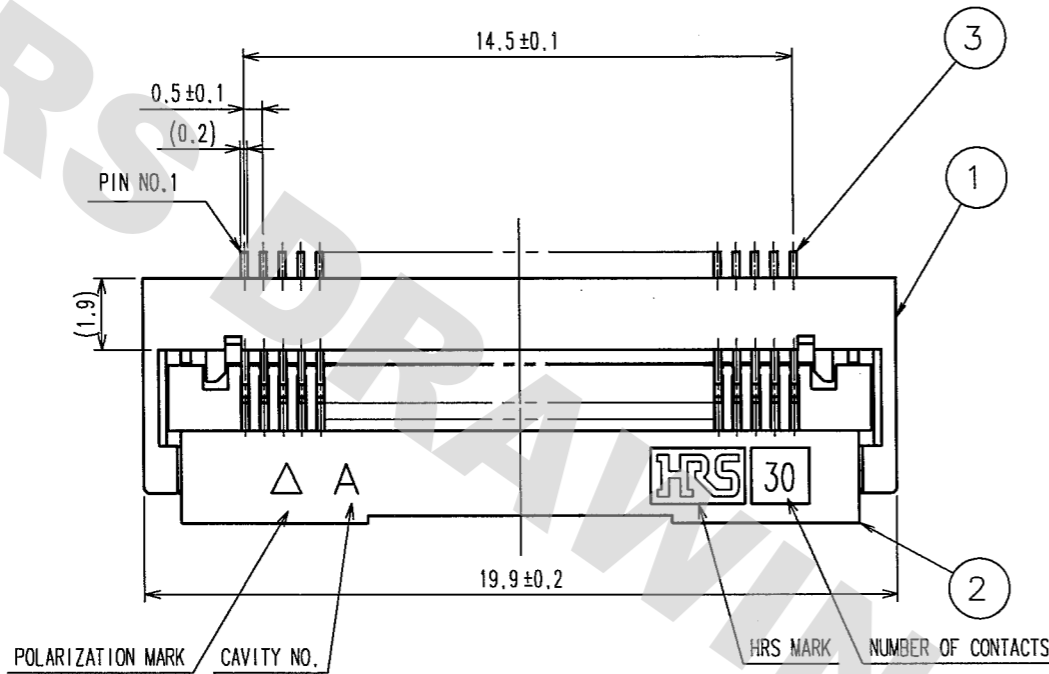
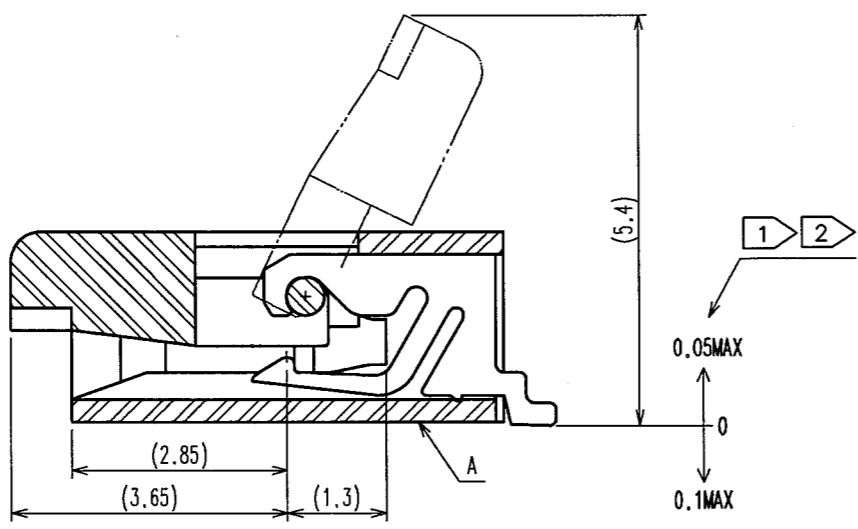

| 2   | LCP      | (BLACK)         | UL94V-0 | 5        | BRASS           | TIN PLATING 1μm MIN. OVER NICKEL 1μm MIN. |
|-----|----------|-----------------|---------|----------|-----------------|---|
| 1   | LCP      | (GRAY)          | UL94V-0 | 4        | BRASS           | TIN PLATING 1μm MIN. OVER NICKEL 1μm MIN. |
|     |          |                 |         | 3        | PHOSPHOR BRONZE | GOLD PLATING FLASH OVER NICKEL 1μm MIN.   |
| NO. | MATERIAL | FINISH, REMARKS | NO.     | MATERIAL | FINISH, REMARKS |   |

|                      |                                 |                                   |                                   |                                    |          |
|----------------------|---------------------------------|-----------------------------------|-----------------------------------|------------------------------------|----------|
| CODE NO: (OLD)<br>CL | DRAWN<br>K.FURUKAWA<br>05.03.25 | DESIGNED<br>H.TSUKUMO<br>05.03.25 | CHECKED<br>R. Takayan<br>05.03.26 | APPROVED<br>R. Takayan<br>05.03.26 | RELEASED |
|----------------------|---------------------------------|-----------------------------------|-----------------------------------|------------------------------------|----------|

|                |                                 |                                 |
|----------------|---------------------------------|---------------------------------|
| SCALE<br>5 : 1 | DRAWING NO.<br>EDC3-155705-01   | PART NO.<br>FH28D-30S-0.5SH(05) |
| UNITS<br>mm    | HRS<br>HIROSE ELECTRIC CO., LTD | CODE NO.<br>CL586-1827-6-05     |



DRAWING FOR REFERENCE: This is subject to change without notice  
08/11/2012

|    |
|----|
| TO |
| NC |
|    |
|    |

DRAWING FOR REFERENCE: This is subject to change without notice  
08/11/2012

|    |
|----|
| TO |
| NC |
|    |
|    |

| COUNT | DESCRIPTION OF REVISIONS | BY | CHKD | DATE | COUNT | DESCRIPTION OF REVISIONS | BY | CHKD | DATE |
|-------|--------------------------|----|------|------|-------|--------------------------|----|------|------|
|       |                          |    |      |      |       |                          |    |      |      |
|       |                          |    |      |      |       |                          |    |      |      |
|       |                          |    |      |      |       |                          |    |      |      |

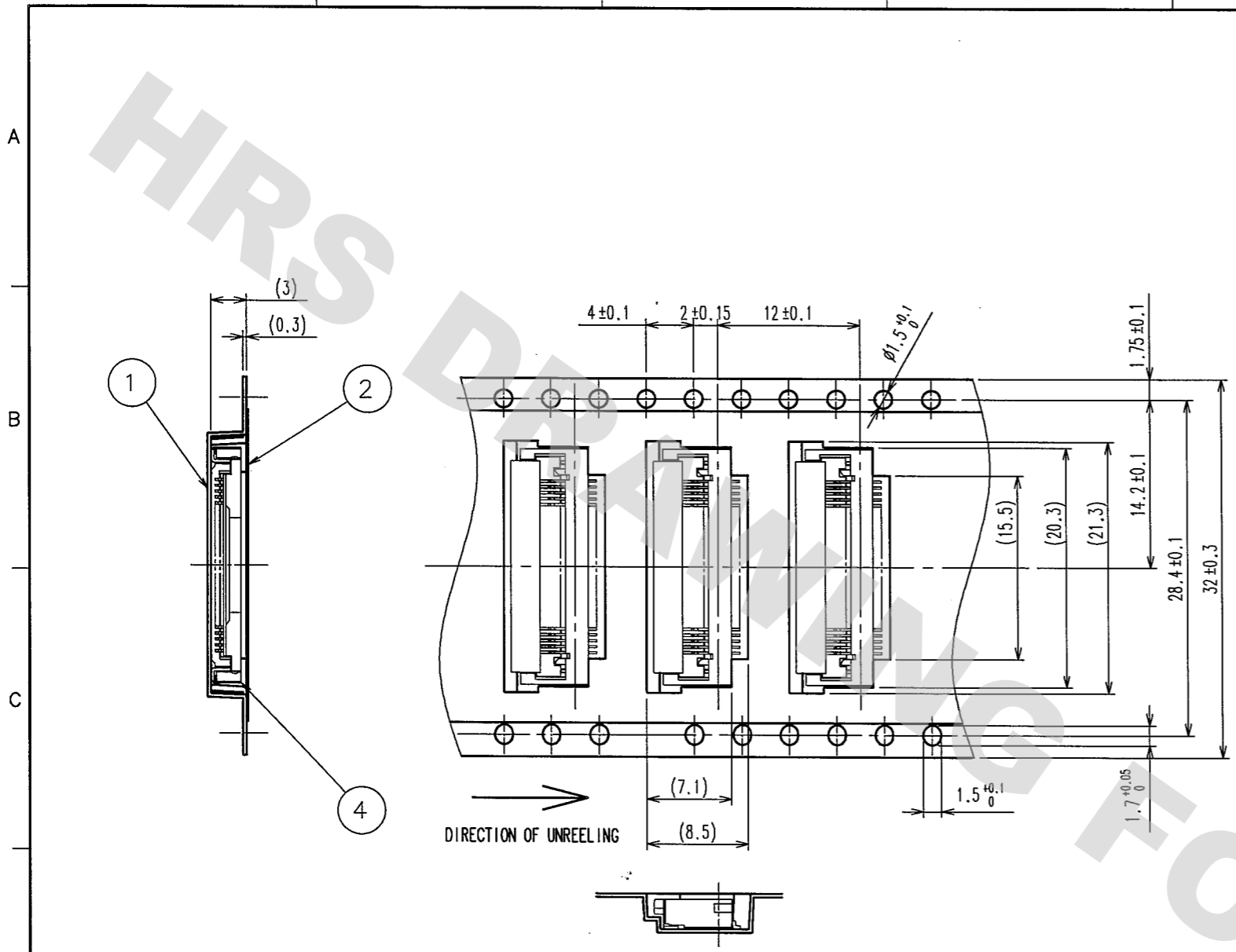

REEL DIMENSION (FREE)

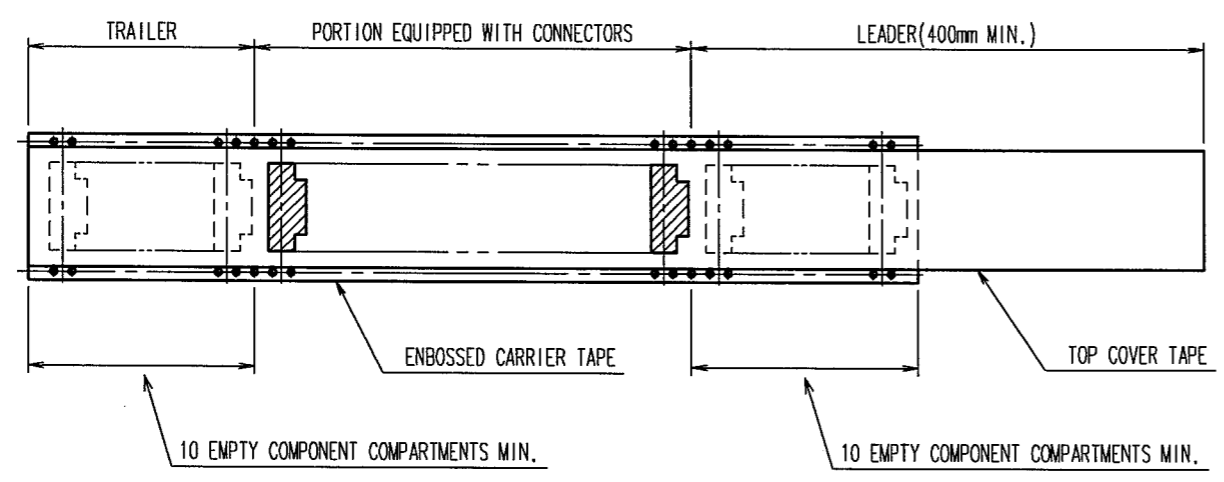
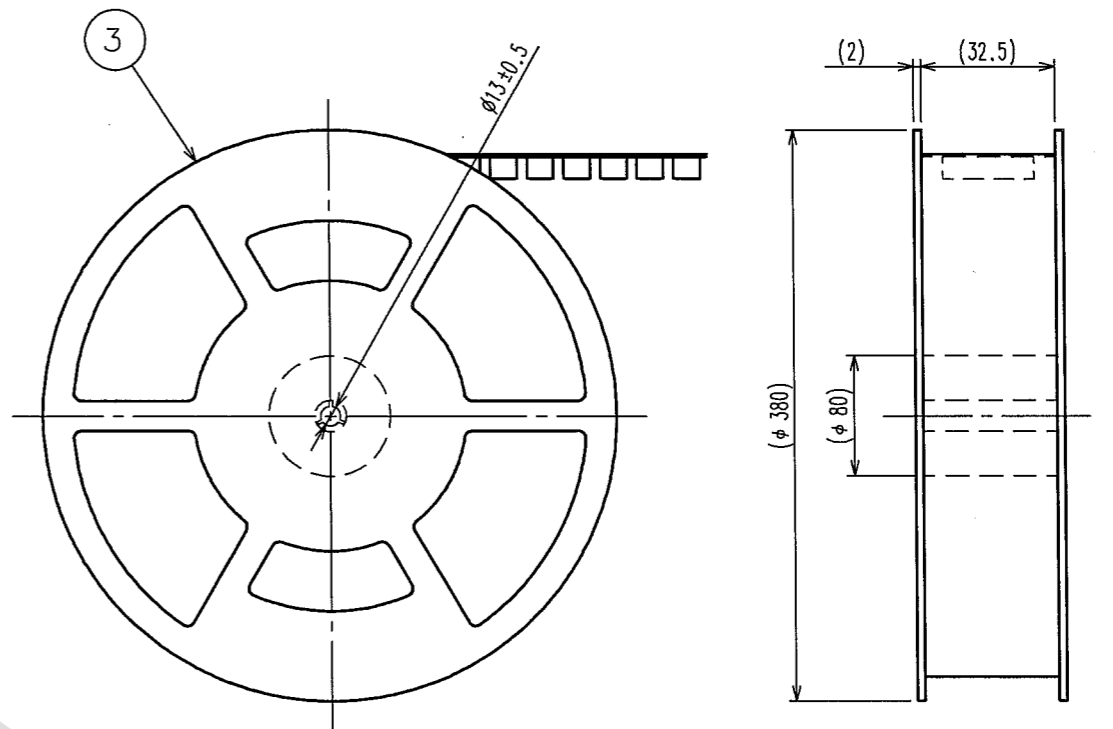

- NOTE 1 THE DIMENSIONS IN PARENTHESES ARE FOR REFERENCE.  
 2 PER REEL : 2000 CONNECTORS.  
 3 REFER TO JIS C 0806 (PACKAGING OF COMPONENTS FOR AUTOMATIC HANDLING).

| 2                             | POLYESTER   |                                 | 4                                 | (CONNECTOR)                       |                                    |
|-------------------------------|-------------|---------------------------------|-----------------------------------|-----------------------------------|------------------------------------|
| 1                             | POLYSTYRENE |                                 | 3                                 | POLYSTYRENE                       |                                    |
| NO.                           | MATERIAL    | FINISH, REMARKS                 | NO.                               | MATERIAL                          | FINISH, REMARKS                    |
| CODE NO. (OLD)<br>CL          |             | DRAWN<br>K.FURUKAWA<br>05.03.25 | DESIGNED<br>H.TSUKUMO<br>05.03.25 | CHECKED<br>R. Takayan<br>05.03.26 | APPROVED<br>R. Takayan<br>05.03.26 |
| DRAWING FOR PACKING           |             |                                 | RELEASED                          |                                   |                                    |
| DRAWING NO.<br>EDC3-155705-01 |             |                                 | PART NO.<br>FH28D-30S-0.5SH(05)   |                                   |                                    |
| SCALE<br>2 : 1                |             |                                 | CODE NO.<br>CL586-1827-6-05       |                                   |                                    |
| UNITS<br>mm                   |             |                                 | HRS HIROSE ELECTRIC CO., LTD      |                                   |                                    |

