

LM56 Dual Output Low Power Thermostat

Check for Samples: [LM56](#)

FEATURES

- Digital Outputs Support TTL Logic Levels
- Internal Temperature Sensor
- 2 Internal Comparators with Hysteresis
- Internal Voltage Reference
- Available in 8-pin SOIC and VSSOP Packages

APPLICATIONS

- Microprocessor Thermal Management
- Appliances
- Portable Battery Powered 3.0V or 5V Systems
- Fan Control
- Industrial Process Control
- HVAC Systems
- Remote Temperature Sensing
- Electronic System Protection

DESCRIPTION

The LM56 is a precision low power thermostat. Two stable temperature trip points (V_{T1} and V_{T2}) are generated by dividing down the LM56 1.250V bandgap voltage reference using 3 external resistors. The LM56 has two digital outputs. OUT1 goes LOW when the temperature exceeds T1 and goes HIGH when the the temperature goes below ($T1 - T_{HYST}$). Similarly, OUT2 goes LOW when the temperature exceeds T2 and goes HIGH when the temperature goes below ($T2 - T_{HYST}$). T_{HYST} is an internally set 5°C typical hysteresis.

The LM56 is available in an 8-lead VSSOP surface mount package and an 8-lead SOIC.

Table 1. Key Specifications

	VALUE	UNIT
Power Supply Voltage	2.7V–10	V
Power Supply Current	230	μA (max)
V_{REF}	1.250	V ±1% (max)
Hysteresis Temperature	5	°C
Internal Temperature Sensor Output Voltage	$(+6.20 \text{ mV}/^{\circ}\text{C} \times T) + 395 \text{ mV}$	mV

Table 2. Temperature Trip Point Accuracy

	LM56BIM	LM56CIM
+25°C	±2°C (max)	±3°C (max)
+25°C to +85°C	±2°C (max)	±3°C (max)
–40°C to +125°C	±3°C (max)	±4°C (max)



Please be aware that an important notice concerning availability, standard warranty, and use in critical applications of Texas Instruments semiconductor products and disclaimers thereto appears at the end of this data sheet.

All trademarks are the property of their respective owners.

Simplified Block Diagram and Connection Diagram

Block Diagram

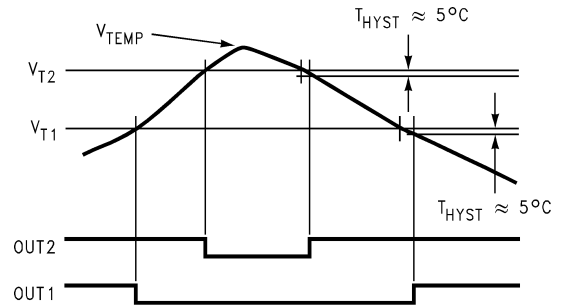
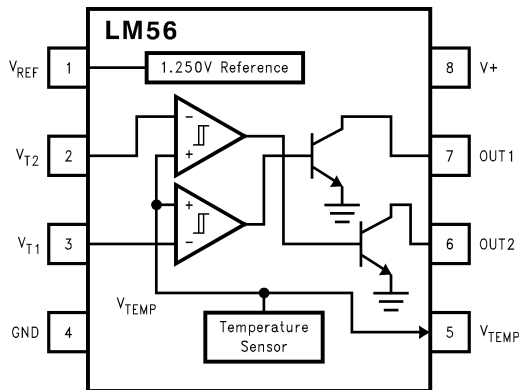

Typical Application

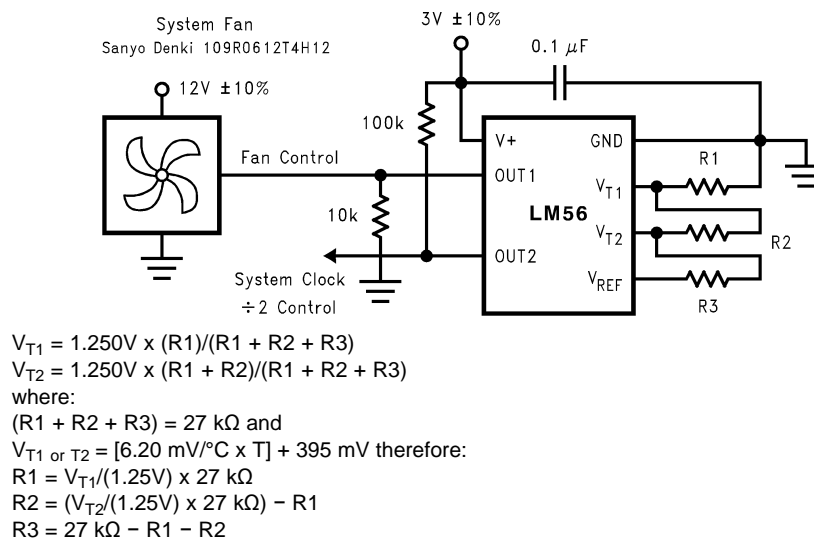

Figure 1. Microprocessor Thermal Management



These devices have limited built-in ESD protection. The leads should be shorted together or the device placed in conductive foam during storage or handling to prevent electrostatic damage to the MOS gates.

Absolute Maximum Ratings⁽¹⁾

Input Voltage		12V
Input Current at any pin ⁽²⁾		5 mA
Package Input Current ⁽²⁾		20 mA
Package Dissipation at T _A = 25°C ⁽³⁾		900 mW
ESD Susceptibility ⁽⁴⁾	Human Body Model - Pin 3 Only	800V
	All other pins	1000V
	Machine Model	125V
	Storage Temperature	-65°C to + 150°C

- (1) Absolute Maximum Ratings indicate limits beyond which damage to the device may occur. Operating Ratings indicate conditions for which the device is functional, but do not guarantee specific performance limits. For guaranteed specifications and test conditions, see the [LM56 Electrical Characteristics](#). The guaranteed specifications apply only for the test conditions listed. Some performance characteristics may degrade when the device is not operated under the listed test conditions.
- (2) When the input voltage (V_I) at any pin exceeds the power supply (V_I < GND or V_I > V⁺), the current at that pin should be limited to 5 mA. The 20 mA maximum package input current rating limits the number of pins that can safely exceed the power supplies with an input current of 5 mA to four.
- (3) The maximum power dissipation must be derated at elevated temperatures and is dictated by T_{Jmax} (maximum junction temperature), θ_{JA} (junction to ambient thermal resistance) and T_A (ambient temperature). The maximum allowable power dissipation at any temperature is P_D = (T_{Jmax} - T_A) / θ_{JA} or the number given in the Absolute Maximum Ratings, whichever is lower. For this device, T_{Jmax} = 125°C. For this device the typical thermal resistance (θ_{JA}) of the different package types when board mounted follow:
- (4) The human body model is a 100 pF capacitor discharge through a 1.5 kΩ resistor into each pin. The machine model is a 200 pF capacitor discharged directly into each pin.

Operating Ratings⁽¹⁾⁽²⁾⁽³⁾

Operating Temperature Range	T_{MIN} ≤ T_A ≤ T_{MAX}
LM56BIM, LM56CIM	-40°C ≤ T _A ≤ +125°C
Positive Supply Voltage (V ⁺)	+2.7V to +10V
Maximum V _{OUT1} and V _{OUT2}	+10V

- (1) Absolute Maximum Ratings indicate limits beyond which damage to the device may occur. Operating Ratings indicate conditions for which the device is functional, but do not guarantee specific performance limits. For guaranteed specifications and test conditions, see the [LM56 Electrical Characteristics](#). The guaranteed specifications apply only for the test conditions listed. Some performance characteristics may degrade when the device is not operated under the listed test conditions.
- (2) Soldering process must comply with Reflow Temperature Profile specifications. Refer to <http://www.ti.com/packaging>.
- (3) Reflow temperature profiles are different for lead-free and non-lead-free packages.

Package Type	θ _{JA}
D0008A	110°C/W
DGK0008A	250°C/W

LM56 Electrical Characteristics

The following specifications apply for $V^+ = 2.7 V_{DC}$, and V_{REF} load current = 50 μA unless otherwise specified. **Boldface limits apply for $T_A = T_J = T_{MIN}$ to T_{MAX}** ; all other limits $T_A = T_J = 25^\circ C$ unless otherwise specified.

Symbol	Parameter	Conditions	Typical ⁽¹⁾	LM56BIM Limits ⁽²⁾	LM56CIM Limits ⁽²⁾	Units (Limits)
Temperature Sensor						
	Trip Point Accuracy (Includes V_{REF} , Comparator Offset, and Temperature Sensitivity errors)	$+25^\circ C \leq T_A \leq +85^\circ C$		± 2	± 3	$^\circ C$ (max)
		$-40^\circ C \leq T_A \leq +125^\circ C$		± 2	± 3	$^\circ C$ (max)
				± 3	± 4	$^\circ C$ (max)
	Trip Point Hysteresis	$T_A = -40^\circ C$	4	3	3	$^\circ C$ (min)
				6	6	$^\circ C$ (max)
		$T_A = +25^\circ C$	5	3.5	3.5	$^\circ C$ (min)
				6.5	6.5	$^\circ C$ (max)
		$T_A = +85^\circ C$	6	4.5	4.5	$^\circ C$ (min)
				7.5	7.5	$^\circ C$ (max)
		$T_A = +125^\circ C$	6	4	4	$^\circ C$ (min)
				8	8	$^\circ C$ (max)
	Internal Temperature Sensitivity		+6.20			mV/ $^\circ C$
	Temperature Sensitivity Error			± 2	± 3	$^\circ C$ (max)
					± 3	± 4
	Output Impedance	$-1 \mu A \leq I_L \leq +40 \mu A$		1500	1500	Ω (max)
	Line Regulation	$+3.0V \leq V^+ \leq +10V$, $+25^\circ C \leq T_A \leq +85^\circ C$		$-0.72/+0.3$ 6	$-0.72/+0.3$ 6	mV/V (max)
		$+3.0V \leq V^+ \leq +10V$, $-40^\circ C \leq T_A < 25^\circ C$		$-1.14/+0.6$ 1	$-1.14/+0.6$ 1	mV/V (max)
		$+2.7V \leq V^+ \leq +3.3V$		± 2.3	± 2.3	mV (max)
V_{T1} and V_{T2} Analog Inputs						
I_{BIAS}	Analog Input Bias Current		150	300	300	nA (max)
V_{IN}	Analog Input Voltage Range		$V^+ - 1$			V
			GND			V
V_{OS}	Comparator Offset		2	8	8	mV (max)
V_{REF} Output						
V_{REF}	V_{REF} Nominal		1.250V			V
	V_{REF} Error			± 1	± 1	% (max)
				± 12.5	± 12.5	mV (max)
$\Delta V_{REF}/\Delta V^+$	Line Regulation	$+3.0V \leq V^+ \leq +10V$	0.13	0.25	0.25	mV/V (max)
		$+2.7V \leq V^+ \leq +3.3V$	0.15	1.1	1.1	mV (max)
$\Delta V_{REF}/\Delta I_L$	Load Regulation Sourcing	$+30 \mu A \leq I_L \leq +50 \mu A$		0.15	0.15	mV/ μA (max)

(1) Typicals are at $T_J = T_A = 25^\circ C$ and represent most likely parametric norm.

(2) Limits are guaranteed to TI's AOQL (Average Outgoing Quality Level).

Symbol	Parameter	Conditions	Typical ⁽¹⁾	Limits ⁽²⁾	Units (Limits)
V^+ Power Supply					
I_S	Supply Current	$V^+ = +10V$		230	μA (max)
		$V^+ = +2.7V$		230	μA (max)
Digital Outputs					
$I_{OUT("1")}$	Logical "1" Output Leakage Current	$V^+ = +5.0V$		1	μA (max)
$V_{OUT("0")}$	Logical "0" Output Voltage	$I_{OUT} = +50 \mu A$		0.4	V (max)

(1) Typicals are at $T_J = T_A = 25^\circ C$ and represent most likely parametric norm.

(2) Limits are guaranteed to TI's AOQL (Average Outgoing Quality Level).

Typical Performance Characteristics

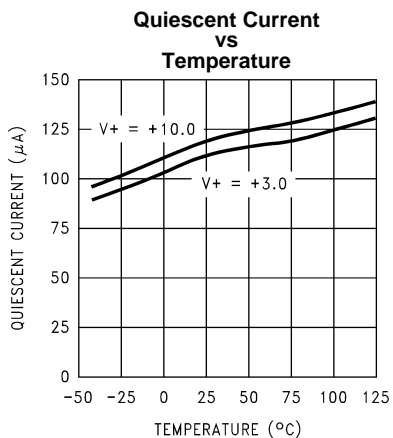

Figure 2.

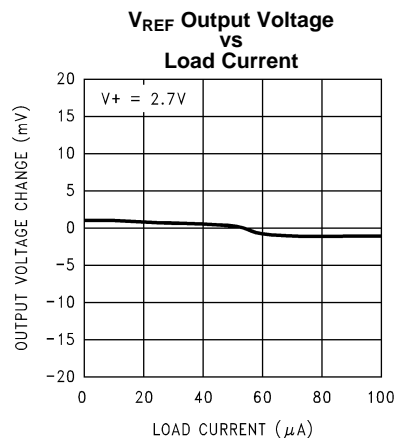

Figure 3.

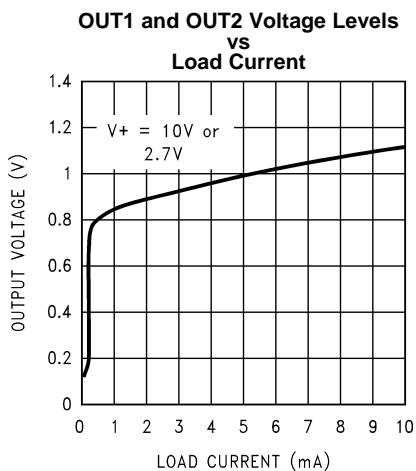

Figure 4.

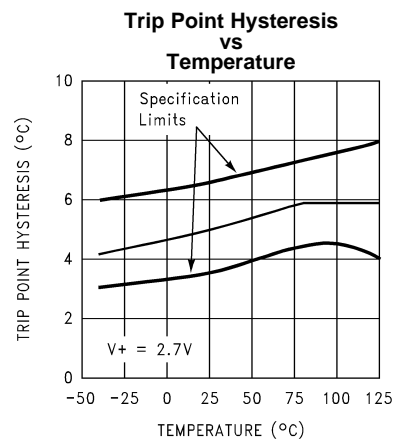

Figure 5.

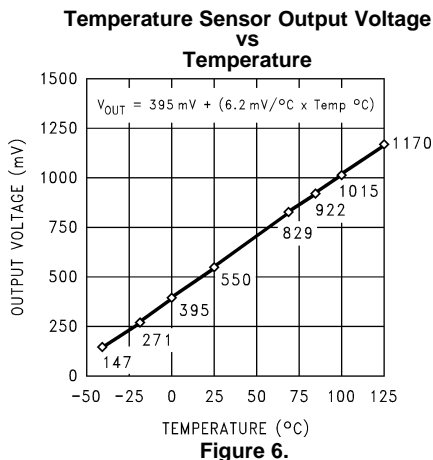

Figure 6.

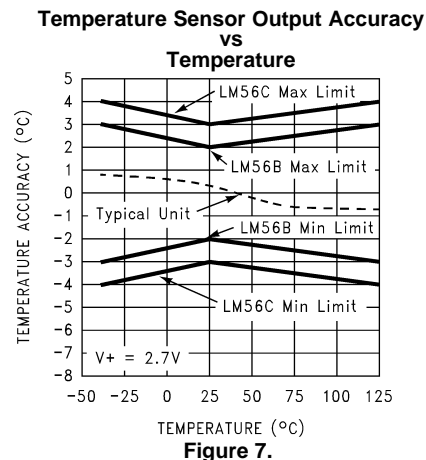

Figure 7.

Typical Performance Characteristics (continued)

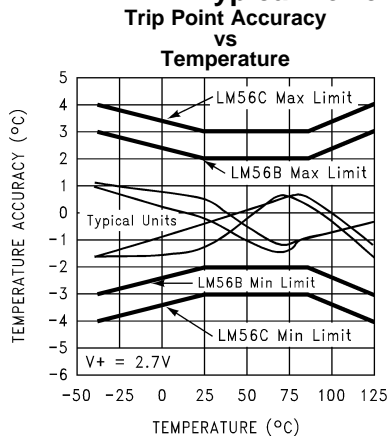

Figure 8.

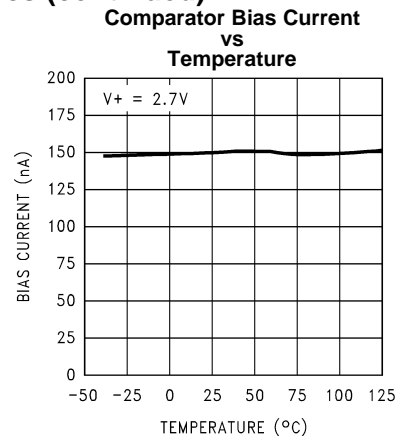

Figure 9.

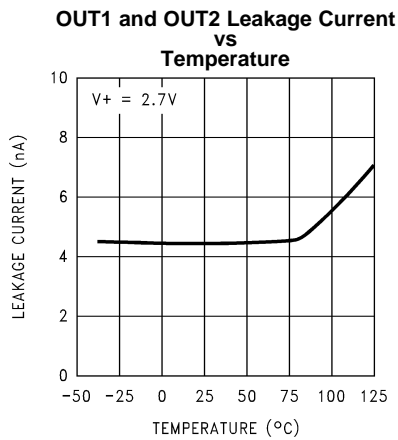

Figure 10.

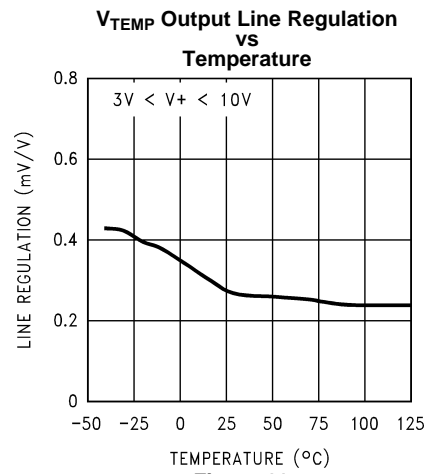

Figure 11.

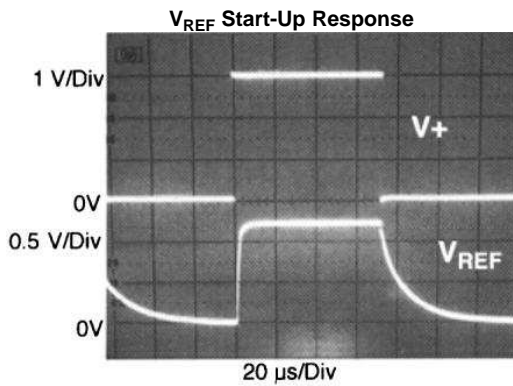

Figure 12.

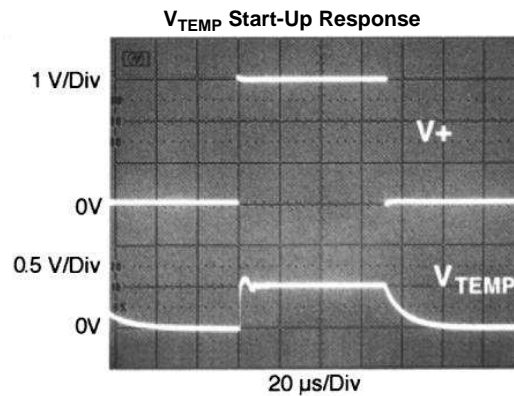
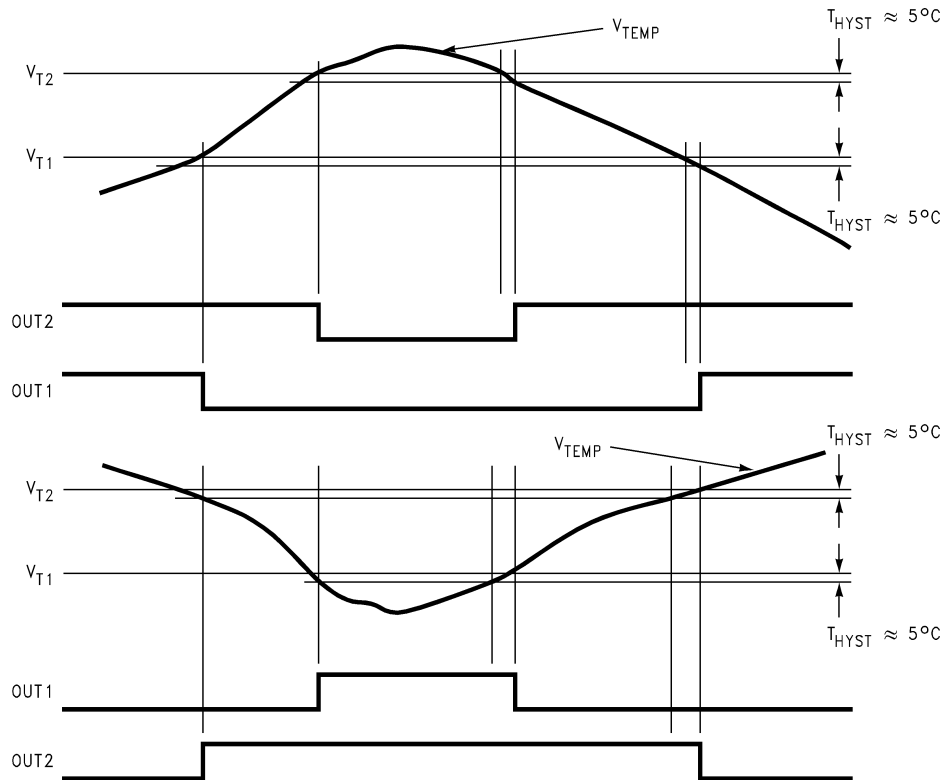

Figure 13.

FUNCTIONAL DESCRIPTION



Pin Functions

V ⁺	This is the positive supply voltage pin. This pin should be bypassed with a 0.1 μF capacitor to ground.
GND	This is the ground pin.
V _{REF}	This is the 1.250V bandgap voltage reference output pin. In order to maintain trip point accuracy this pin should source a 50 μA load.
V _{TEMP}	This is the temperature sensor output pin.
OUT1	This is an open collector digital output. OUT1 is active LOW. It goes LOW when the temperature is greater than T ₁ and goes HIGH when the temperature drops below T ₁ – 5°C. This output is not intended to directly drive a fan motor.
OUT2	This is an open collector digital output. OUT2 is active LOW. It goes LOW when the temperature is greater than the T ₂ set point and goes HIGH when the temperature is less than T ₂ – 5°C. This output is not intended to directly drive a fan motor.
V _{T1}	This is the input pin for the temperature trip point voltage for OUT1.
V _{T2}	This is the input pin for the low temperature trip point voltage for OUT2.

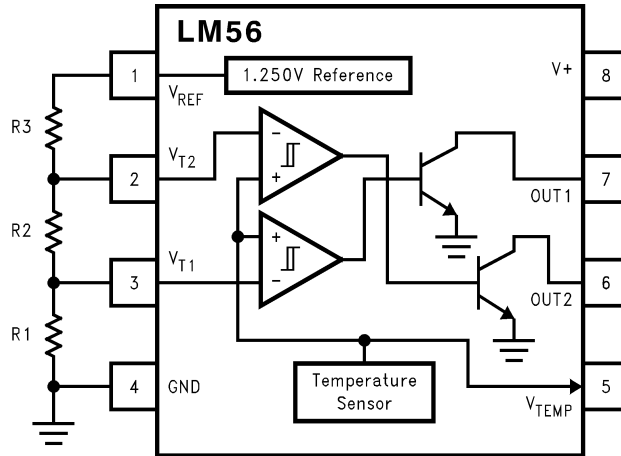

$$V_{T1} = 1.250V \times (R1)/(R1 + R2 + R3)$$

$$V_{T2} = 1.250V \times (R1 + R2)/(R1 + R2 + R3)$$

where:

$$(R1 + R2 + R3) = 27 \text{ k}\Omega \text{ and}$$

$$V_{T1 \text{ or } T2} = [6.20 \text{ mV}/^\circ\text{C} \times T] + 395 \text{ mV} \text{ therefore:}$$

$$R1 = V_{T1}/(1.25V) \times 27 \text{ k}\Omega$$

$$R2 = (V_{T2}/(1.25V) \times 27 \text{ k}\Omega) - R1$$

$$R3 = 27 \text{ k}\Omega - R1 - R2$$

Application Hints

LM56 TRIP POINT ACCURACY SPECIFICATION

For simplicity the following is an analysis of the trip point accuracy using the single output configuration shown in Figure 14 with a set point of 82°C.

Trip Point Error Voltage = V_{TPE} ,

Comparator Offset Error for V_{T1E}

Temperature Sensor Error = V_{TSE}

Reference Output Error = V_{RE}

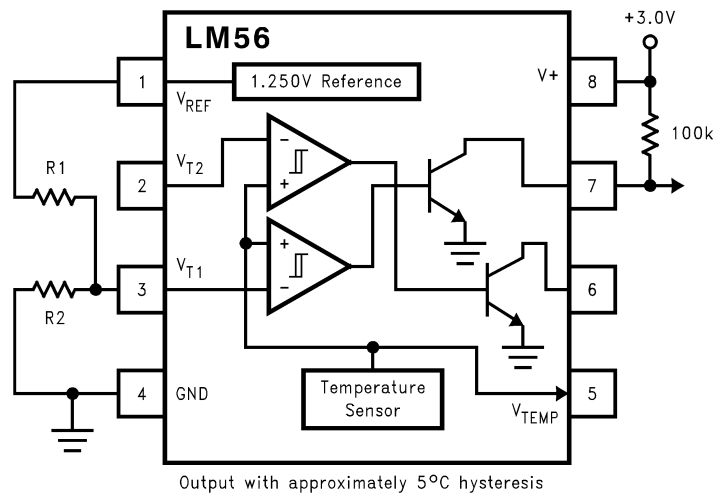

Figure 14. Single Output Configuration

$$1. V_{TPE} = \pm V_{T1E} - V_{TSE} + V_{RE}$$

Where:

$$2. V_{T1E} = \pm 8 \text{ mV (max)}$$

$$3. V_{TSE} = (6.20 \text{ mV/}^\circ\text{C}) \times (\pm 3^\circ\text{C}) = \pm 18.6 \text{ mV}$$

$$4. V_{RE} = 1.250\text{V} \times (\pm 0.01) R2/(R1 + R2)$$

Using Equations from [Figure 1](#).

$$V_{T1} = 1.25\text{V} \times R2/(R1 + R2) = 6.20 \text{ mV/}^\circ\text{C}(82^\circ\text{C}) + 395 \text{ mV}$$

$$\text{Solving for } R2/(R1 + R2) = 0.7227$$

then,

$$5. V_{RE} = 1.250\text{V} \times (\pm 0.01) R2/(R1 + R2) = (0.0125) \times (0.7227) = \pm 9.03 \text{ mV}$$

The individual errors do not add algebraically because, the odds of all the errors being at their extremes are rare. This is proven by the fact the specification for the trip point accuracy stated in the [LM56 Electrical Characteristics](#) for the temperature range of -40°C to $+125^\circ\text{C}$, for example, is specified at $\pm 3^\circ\text{C}$ for the LM56BIM. Note this trip point error specification does not include any error introduced by the tolerance of the actual resistors used, nor any error introduced by power supply variation.

If the resistors have a $\pm 0.5\%$ tolerance, an additional error of $\pm 0.4^\circ\text{C}$ will be introduced. This error will increase to $\pm 0.8^\circ\text{C}$ when both external resistors have a $\pm 1\%$ tolerance.

BIAS CURRENT EFFECT ON TRIP POINT ACCURACY

Bias current for the comparator inputs is 300 nA (max) each, over the specified temperature range and will not introduce considerable error if the sum of the resistor values are kept to about 27 k Ω as shown in the typical application of [Figure 1](#). This bias current of one comparator input will not flow if the temperature is well below the trip point level. As the temperature approaches trip point level the bias current will start to flow into the resistor network. When the temperature sensor output is equal to the trip point level the bias current will be 150 nA (max). Once the temperature is well above the trip point level the bias current will be 300 nA (max). Therefore, the first trip point will be affected by 150 nA of bias current. The leakage current is very small when the comparator input transistor of the different pair is off (see [Figure 15](#)).

The effect of the bias current on the first trip point can be defined by the following equations:

$$K1 = \frac{R1}{R1 + R2 + R3}$$

$$V_{T1} = K1 \times V_{REF} + K1 \times (R2 + R3) \times \frac{I_B}{2} \quad (1)$$

where $I_B = 300 \text{ nA}$ (the maximum specified error).

The effect of the bias current on the second trip point can be defined by the following equations:

$$K2 = \frac{R1 + R2}{R1 + R2 + R3}$$

$$V_{T2} = K2 \times V_{REF} + \left(K1 + \frac{K2}{2} \right) \times R3 \times I_B \quad (2)$$

where $I_B = 300 \text{ nA}$ (the maximum specified error).

The closer the two trip points are to each other the more significant the error is. Worst case would be when $V_{T1} = V_{T2} = V_{REF}/2$.

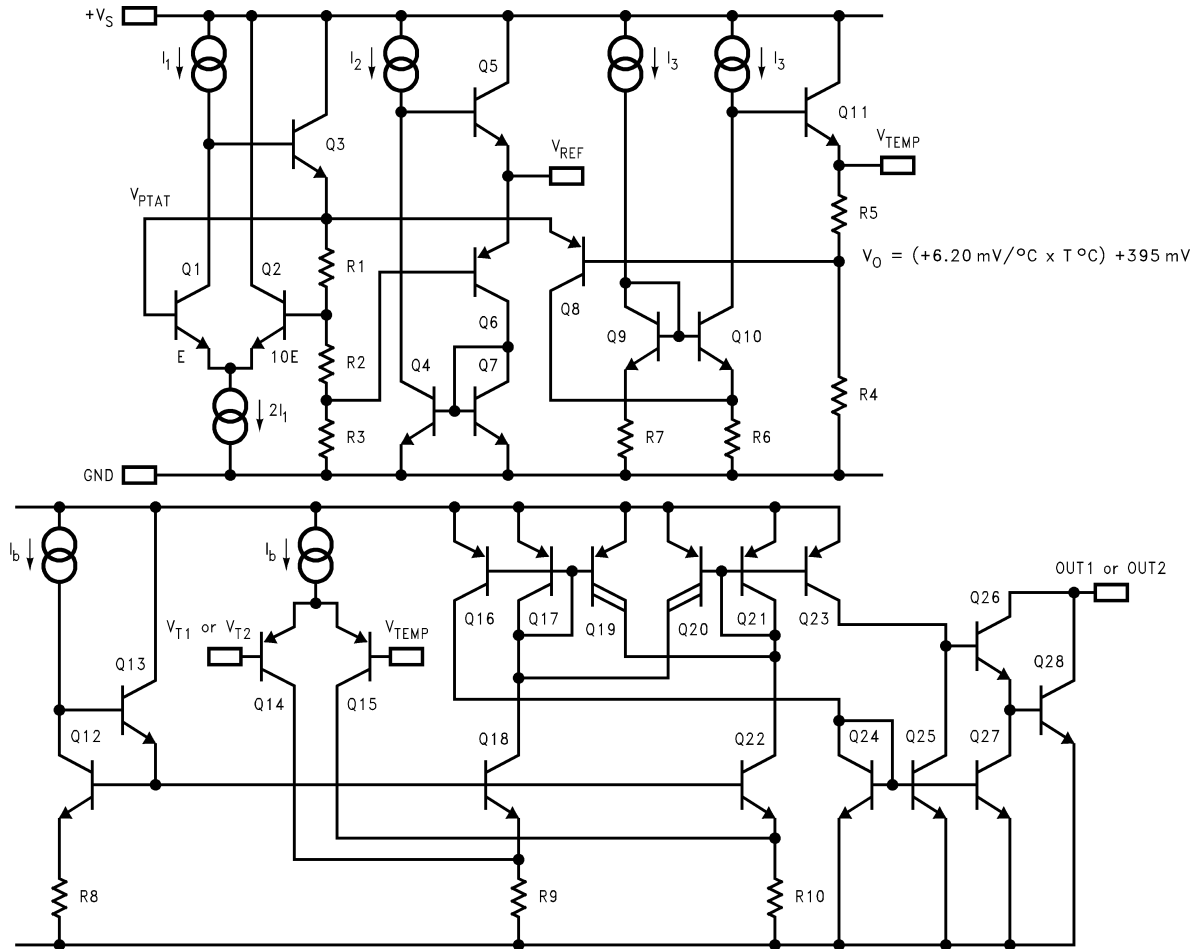

Figure 15. Simplified Schematic

MOUNTING CONSIDERATIONS

The majority of the temperature that the LM56 is measuring is the temperature of its leads. Therefore, when the LM56 is placed on a printed circuit board, it is not sensing the temperature of the ambient air. It is actually sensing the temperature difference of the air and the lands and printed circuit board that the leads are attached to. The most accurate temperature sensing is obtained when the ambient temperature is equivalent to the LM56's lead temperature.

As with any IC, the LM56 and accompanying wiring and circuits must be kept insulated and dry, to avoid leakage and corrosion. This is especially true if the circuit operates at cold temperatures where condensation can occur. Printed-circuit coatings are often used to ensure that moisture cannot corrode the LM56 or its connections.

The circuit shown in Figure 17 will reduce the effective bias current error for V_{T2} as discussed in Section 3.0 to be equivalent to the error term of V_{T1} . For this circuit the effect of the bias current on the first trip point can be defined by the following equations:

$$K1 = \frac{R2}{R1 + R2}$$

$$V_{T1} = K1 \times V_{REF} + K1 \times (R1) \times \frac{I_B}{2} \tag{3}$$

where $I_B = 300 \text{ nA}$ (the maximum specified error).

Similarly, bias current affect on V_{T2} can be defined by:

$$K2 = \frac{R4}{R3 + R4}$$

$$V_{T1} = K2 \times V_{REF} + K1 \times (R3) \times \frac{I_B}{2} \tag{4}$$

where $I_B = 300 \text{ nA}$ (the maximum specified error).

The current shown in Figure 18 is a simple overtemperature detector for power devices. In this example, an audio power amplifier IC is bolted to a heat sink and an LM56 Celsius temperature sensor is mounted on a PC board that is bolted to the heat sink near the power amplifier. To ensure that the sensing element is at the same temperature as the heat sink, the sensor's leads are mounted to pads that have feed throughs to the back side of the PC board. Since the LM56 is sensing the temperature of the actual PC board the back side of the PC board also has large ground plane to help conduct the heat to the device. The comparator's output goes low if the heat sink temperature rises above a threshold set by R1, R2, and the voltage reference. This fault detection output from the comparator now can be used to turn on a cooling fan. The circuit as shown in design to turn the fan on when heat sink temperature exceeds about 80°C, and to turn the fan off when the heat sink temperature falls below approximately 75°C.

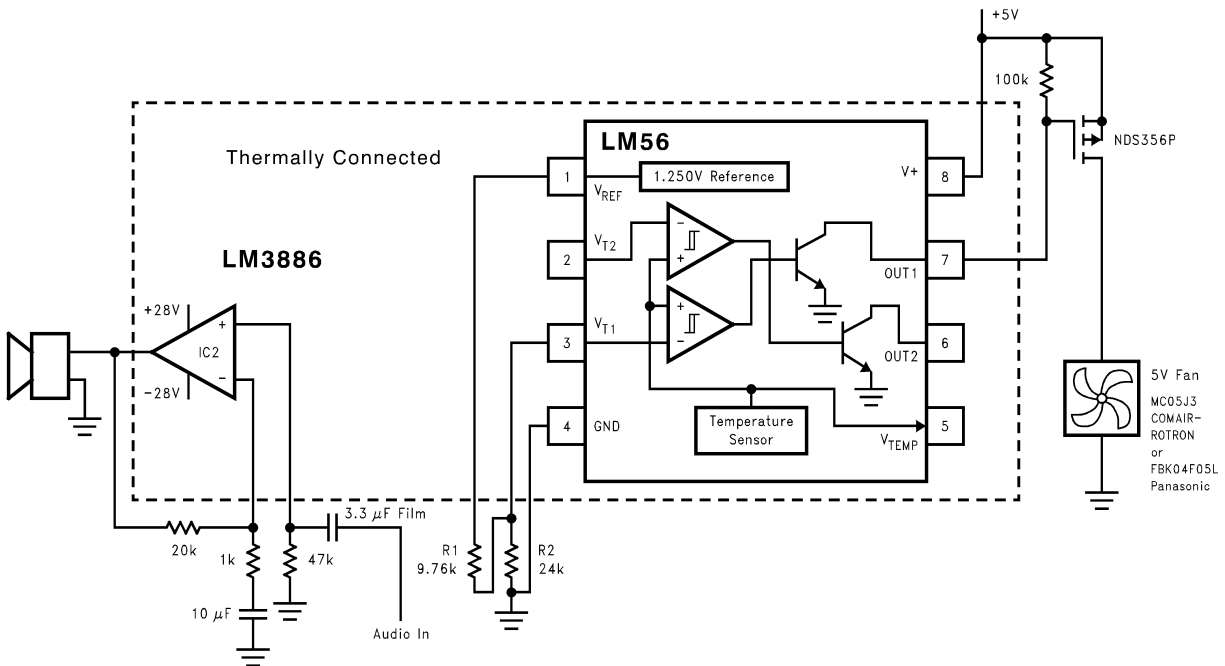

Figure 18. Audio Power Amplifier Overtemperature Detector

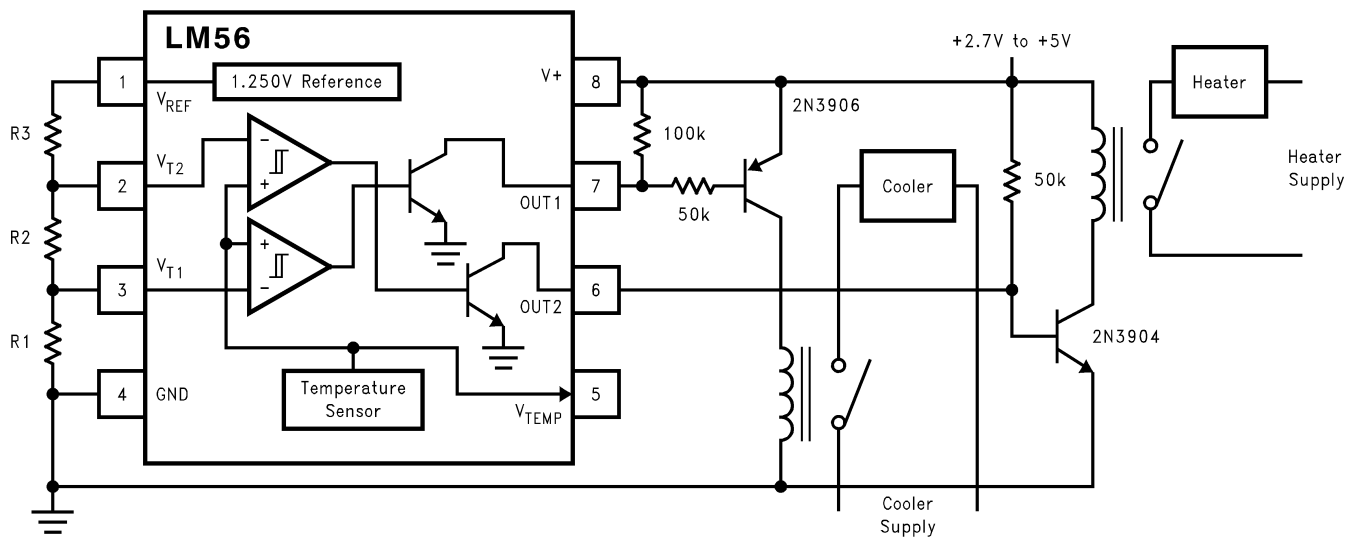

Figure 19. Simple Thermostat

REVISION HISTORY

Changes from Revision F (February 2013) to Revision G	Page
• Changed layout of National Data Sheet to TI format	13

PACKAGING INFORMATION

Orderable Device	Status (1)	Package Type	Package Drawing	Pins	Package Qty	Eco Plan (2)	Lead/Ball Finish (6)	MSL Peak Temp (3)	Op Temp (°C)	Device Marking (4/5)	Samples
LM56BIM	NRND	SOIC	D	8	95	TBD	Call TI	Call TI	-40 to 125	LM56 BIM	
LM56BIM/NOPB	ACTIVE	SOIC	D	8	95	Green (RoHS & no Sb/Br)	CU SN	Level-1-260C-UNLIM	-40 to 125	LM56 BIM	Samples
LM56BIMM	NRND	VSSOP	DGK	8	1000	TBD	Call TI	Call TI	-40 to 125	T02B	
LM56BIMM/NOPB	ACTIVE	VSSOP	DGK	8	1000	Green (RoHS & no Sb/Br)	CU SN	Level-1-260C-UNLIM	-40 to 125	T02B	Samples
LM56BIMMX/NOPB	ACTIVE	VSSOP	DGK	8	3500	Green (RoHS & no Sb/Br)	CU SN	Level-1-260C-UNLIM	-40 to 125	T02B	Samples
LM56BIMX	NRND	SOIC	D	8	2500	TBD	Call TI	Call TI	-40 to 125	LM56 BIM	
LM56BIMX/NOPB	ACTIVE	SOIC	D	8	2500	Green (RoHS & no Sb/Br)	CU SN	Level-1-260C-UNLIM	-40 to 125	LM56 BIM	Samples
LM56CIM	NRND	SOIC	D	8	95	TBD	Call TI	Call TI	-40 to 125	LM56 CIM	
LM56CIM/NOPB	ACTIVE	SOIC	D	8	95	Green (RoHS & no Sb/Br)	CU SN	Level-1-260C-UNLIM	-40 to 125	LM56 CIM	Samples
LM56CIMM/NOPB	ACTIVE	VSSOP	DGK	8	1000	Green (RoHS & no Sb/Br)	CU SN	Level-1-260C-UNLIM	-40 to 125	T02C	Samples
LM56CIMMX/NOPB	ACTIVE	VSSOP	DGK	8	3500	Green (RoHS & no Sb/Br)	CU SN	Level-1-260C-UNLIM	-40 to 125	T02C	Samples
LM56CIMX	NRND	SOIC	D	8	2500	TBD	Call TI	Call TI	-40 to 125	LM56 CIM	
LM56CIMX/NOPB	ACTIVE	SOIC	D	8	2500	Green (RoHS & no Sb/Br)	CU SN	Level-1-260C-UNLIM	-40 to 125	LM56 CIM	Samples

(1) The marketing status values are defined as follows:

ACTIVE: Product device recommended for new designs.

LIFEBUY: TI has announced that the device will be discontinued, and a lifetime-buy period is in effect.

NRND: Not recommended for new designs. Device is in production to support existing customers, but TI does not recommend using this part in a new design.

PREVIEW: Device has been announced but is not in production. Samples may or may not be available.

OBSELETE: TI has discontinued the production of the device.

(2) Eco Plan - The planned eco-friendly classification: Pb-Free (RoHS), Pb-Free (RoHS Exempt), or Green (RoHS & no Sb/Br) - please check <http://www.ti.com/productcontent> for the latest availability information and additional product content details.

TBD: The Pb-Free/Green conversion plan has not been defined.

Pb-Free (RoHS): TI's terms "Lead-Free" or "Pb-Free" mean semiconductor products that are compatible with the current RoHS requirements for all 6 substances, including the requirement that lead not exceed 0.1% by weight in homogeneous materials. Where designed to be soldered at high temperatures, TI Pb-Free products are suitable for use in specified lead-free processes.

Pb-Free (RoHS Exempt): This component has a RoHS exemption for either 1) lead-based flip-chip solder bumps used between the die and package, or 2) lead-based die adhesive used between the die and leadframe. The component is otherwise considered Pb-Free (RoHS compatible) as defined above.

Green (RoHS & no Sb/Br): TI defines "Green" to mean Pb-Free (RoHS compatible), and free of Bromine (Br) and Antimony (Sb) based flame retardants (Br or Sb do not exceed 0.1% by weight in homogeneous material)

(3) MSL, Peak Temp. - The Moisture Sensitivity Level rating according to the JEDEC industry standard classifications, and peak solder temperature.

(4) There may be additional marking, which relates to the logo, the lot trace code information, or the environmental category on the device.

(5) Multiple Device Markings will be inside parentheses. Only one Device Marking contained in parentheses and separated by a "~" will appear on a device. If a line is indented then it is a continuation of the previous line and the two combined represent the entire Device Marking for that device.

(6) Lead/Ball Finish - Orderable Devices may have multiple material finish options. Finish options are separated by a vertical ruled line. Lead/Ball Finish values may wrap to two lines if the finish value exceeds the maximum column width.

Important Information and Disclaimer:The information provided on this page represents TI's knowledge and belief as of the date that it is provided. TI bases its knowledge and belief on information provided by third parties, and makes no representation or warranty as to the accuracy of such information. Efforts are underway to better integrate information from third parties. TI has taken and continues to take reasonable steps to provide representative and accurate information but may not have conducted destructive testing or chemical analysis on incoming materials and chemicals. TI and TI suppliers consider certain information to be proprietary, and thus CAS numbers and other limited information may not be available for release.

In no event shall TI's liability arising out of such information exceed the total purchase price of the TI part(s) at issue in this document sold by TI to Customer on an annual basis.

TAPE AND REEL INFORMATION

QUADRANT ASSIGNMENTS FOR PIN 1 ORIENTATION IN TAPE

*All dimensions are nominal

Device	Package Type	Package Drawing	Pins	SPQ	Reel Diameter (mm)	Reel Width W1 (mm)	A0 (mm)	B0 (mm)	K0 (mm)	P1 (mm)	W (mm)	Pin1 Quadrant
LM56BIMM	VSSOP	DGK	8	1000	178.0	12.4	5.3	3.4	1.4	8.0	12.0	Q1
LM56BIMM/NOPB	VSSOP	DGK	8	1000	178.0	12.4	5.3	3.4	1.4	8.0	12.0	Q1
LM56BIMMX/NOPB	VSSOP	DGK	8	3500	330.0	12.4	5.3	3.4	1.4	8.0	12.0	Q1
LM56BIMX	SOIC	D	8	2500	330.0	12.4	6.5	5.4	2.0	8.0	12.0	Q1
LM56BIMX/NOPB	SOIC	D	8	2500	330.0	12.4	6.5	5.4	2.0	8.0	12.0	Q1
LM56CIMM/NOPB	VSSOP	DGK	8	1000	178.0	12.4	5.3	3.4	1.4	8.0	12.0	Q1
LM56CIMMX/NOPB	VSSOP	DGK	8	3500	330.0	12.4	5.3	3.4	1.4	8.0	12.0	Q1
LM56CIMX	SOIC	D	8	2500	330.0	12.4	6.5	5.4	2.0	8.0	12.0	Q1
LM56CIMX/NOPB	SOIC	D	8	2500	330.0	12.4	6.5	5.4	2.0	8.0	12.0	Q1

TAPE AND REEL BOX DIMENSIONS

*All dimensions are nominal

Device	Package Type	Package Drawing	Pins	SPQ	Length (mm)	Width (mm)	Height (mm)
LM56BIMM	VSSOP	DGK	8	1000	210.0	185.0	35.0
LM56BIMM/NOPB	VSSOP	DGK	8	1000	210.0	185.0	35.0
LM56BIMMX/NOPB	VSSOP	DGK	8	3500	367.0	367.0	35.0
LM56BIMX	SOIC	D	8	2500	367.0	367.0	35.0
LM56BIMX/NOPB	SOIC	D	8	2500	367.0	367.0	35.0
LM56CIMM/NOPB	VSSOP	DGK	8	1000	210.0	185.0	35.0
LM56CIMMX/NOPB	VSSOP	DGK	8	3500	367.0	367.0	35.0
LM56CIMX	SOIC	D	8	2500	367.0	367.0	35.0
LM56CIMX/NOPB	SOIC	D	8	2500	367.0	367.0	35.0



- NOTES:
- A. All linear dimensions are in millimeters.
 - B. This drawing is subject to change without notice.
 - C. Publication IPC-7351 is recommended for alternate designs.
 - D. Laser cutting apertures with trapezoidal walls and also rounding corners will offer better paste release. Customers should contact their board assembly site for stencil design recommendations. Refer to IPC-7525 for other stencil recommendations.
 - E. Customers should contact their board fabrication site for solder mask tolerances between and around signal pads.

IMPORTANT NOTICE

Texas Instruments Incorporated and its subsidiaries (TI) reserve the right to make corrections, enhancements, improvements and other changes to its semiconductor products and services per JESD46, latest issue, and to discontinue any product or service per JESD48, latest issue. Buyers should obtain the latest relevant information before placing orders and should verify that such information is current and complete. All semiconductor products (also referred to herein as "components") are sold subject to TI's terms and conditions of sale supplied at the time of order acknowledgment.

TI warrants performance of its components to the specifications applicable at the time of sale, in accordance with the warranty in TI's terms and conditions of sale of semiconductor products. Testing and other quality control techniques are used to the extent TI deems necessary to support this warranty. Except where mandated by applicable law, testing of all parameters of each component is not necessarily performed.

TI assumes no liability for applications assistance or the design of Buyers' products. Buyers are responsible for their products and applications using TI components. To minimize the risks associated with Buyers' products and applications, Buyers should provide adequate design and operating safeguards.

TI does not warrant or represent that any license, either express or implied, is granted under any patent right, copyright, mask work right, or other intellectual property right relating to any combination, machine, or process in which TI components or services are used. Information published by TI regarding third-party products or services does not constitute a license to use such products or services or a warranty or endorsement thereof. Use of such information may require a license from a third party under the patents or other intellectual property of the third party, or a license from TI under the patents or other intellectual property of TI.

Reproduction of significant portions of TI information in TI data books or data sheets is permissible only if reproduction is without alteration and is accompanied by all associated warranties, conditions, limitations, and notices. TI is not responsible or liable for such altered documentation. Information of third parties may be subject to additional restrictions.

Resale of TI components or services with statements different from or beyond the parameters stated by TI for that component or service voids all express and any implied warranties for the associated TI component or service and is an unfair and deceptive business practice. TI is not responsible or liable for any such statements.

Buyer acknowledges and agrees that it is solely responsible for compliance with all legal, regulatory and safety-related requirements concerning its products, and any use of TI components in its applications, notwithstanding any applications-related information or support that may be provided by TI. Buyer represents and agrees that it has all the necessary expertise to create and implement safeguards which anticipate dangerous consequences of failures, monitor failures and their consequences, lessen the likelihood of failures that might cause harm and take appropriate remedial actions. Buyer will fully indemnify TI and its representatives against any damages arising out of the use of any TI components in safety-critical applications.

In some cases, TI components may be promoted specifically to facilitate safety-related applications. With such components, TI's goal is to help enable customers to design and create their own end-product solutions that meet applicable functional safety standards and requirements. Nonetheless, such components are subject to these terms.

No TI components are authorized for use in FDA Class III (or similar life-critical medical equipment) unless authorized officers of the parties have executed a special agreement specifically governing such use.

Only those TI components which TI has specifically designated as military grade or "enhanced plastic" are designed and intended for use in military/aerospace applications or environments. Buyer acknowledges and agrees that any military or aerospace use of TI components which have **not** been so designated is solely at the Buyer's risk, and that Buyer is solely responsible for compliance with all legal and regulatory requirements in connection with such use.

TI has specifically designated certain components as meeting ISO/TS16949 requirements, mainly for automotive use. In any case of use of non-designated products, TI will not be responsible for any failure to meet ISO/TS16949.

Products

Audio	www.ti.com/audio
Amplifiers	amplifier.ti.com
Data Converters	dataconverter.ti.com
DLP® Products	www.dlp.com
DSP	dsp.ti.com
Clocks and Timers	www.ti.com/clocks
Interface	interface.ti.com
Logic	logic.ti.com
Power Mgmt	power.ti.com
Microcontrollers	microcontroller.ti.com
RFID	www.ti-rfid.com
OMAP Applications Processors	www.ti.com/omap
Wireless Connectivity	www.ti.com/wirelessconnectivity

Applications

Automotive and Transportation	www.ti.com/automotive
Communications and Telecom	www.ti.com/communications
Computers and Peripherals	www.ti.com/computers
Consumer Electronics	www.ti.com/consumer-apps
Energy and Lighting	www.ti.com/energy
Industrial	www.ti.com/industrial
Medical	www.ti.com/medical
Security	www.ti.com/security
Space, Avionics and Defense	www.ti.com/space-avionics-defense
Video and Imaging	www.ti.com/video

TI E2E Community

e2e.ti.com