

M02067

3.3 Volt Laser Driver IC for GbE and Fibre Channel to 2.1 Gbps

The M02067 is a highly integrated, programmable laser driver intended for datacom applications up to 2.1 Gbps. Using differential PECL data inputs, the M02067 supplies the bias and modulation current for driving an edge-emitting laser. The modulation output can be DC-coupled to the laser diode, giving a significant power saving over AC-coupled operation.

The M02067 includes automatic power control to maintain a constant average laser output power over temperature and life. In addition, the modulation current is temperature compensated to minimize variation in extinction ratio over temperature.

Output flags indicate laser end of life as well as failure of the APC circuitry to maintain average output power.

Features

- Rise and fall times <150 ps
- DC or AC-coupled modulation drive
- Independently programmable laser bias and modulation currents
- Bias current to 100 mA and modulation current to 85 mA at $V_{CC} = 3.3V$
- Automatic laser power control, with programmable temperature compensation and 'slow-start'
- Bias and modulation current monitors
- Operates with +3.3V supply

Applications

- Gigabit Ethernet
- Fibre Channel
- 2 x Fibre Channel
- GBIC

Functional Block Diagram

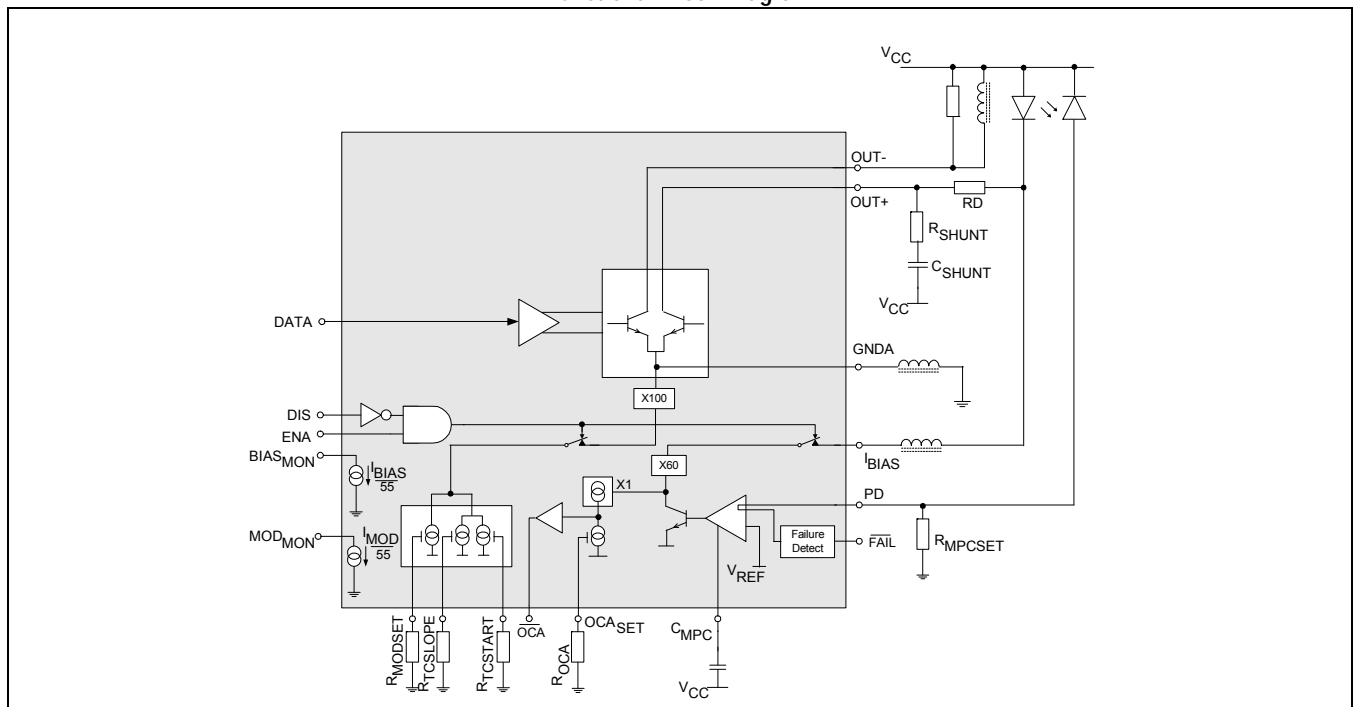

Ordering Information

Part Number	Package
M02067G-12	QFN package (-12 marking)
M02067G-13	QFN package (-12● marking)
M02067-TEVM	TO-Can optical evaluation board
M02067-E-EVM	Electrical evaluation board

Current part number ordering information for this part on mindspeed.com

* The letter "G" designator after the part number indicates that the device is RoHS-compliant. Refer to www.mindspeed.com for additional information.

Revision History

Revision	Level	Date	Description
G	Release	July 2011	Added M02067G-13 ordering information and screen limit.
F	Release	January 2011	Revised R _{MODSET} value in Table 1-3 , Note 4. Revised production test conditions in Table 1-5 .
E	Release	November 2010	Updated ordering information, packaging information. Added DC screen information. Replaced all CX02067 references with M02067.
D	Preliminary	October 2007	Updated ordering information.
C	Preliminary	June 2006	Added RoHS package information, updated format, no specification changes.
B	Preliminary	May 2005	Updated to new data sheet format.
A	Advance	October 2003	Advance.

M02067-12 and M02067-13 Marking Diagrams

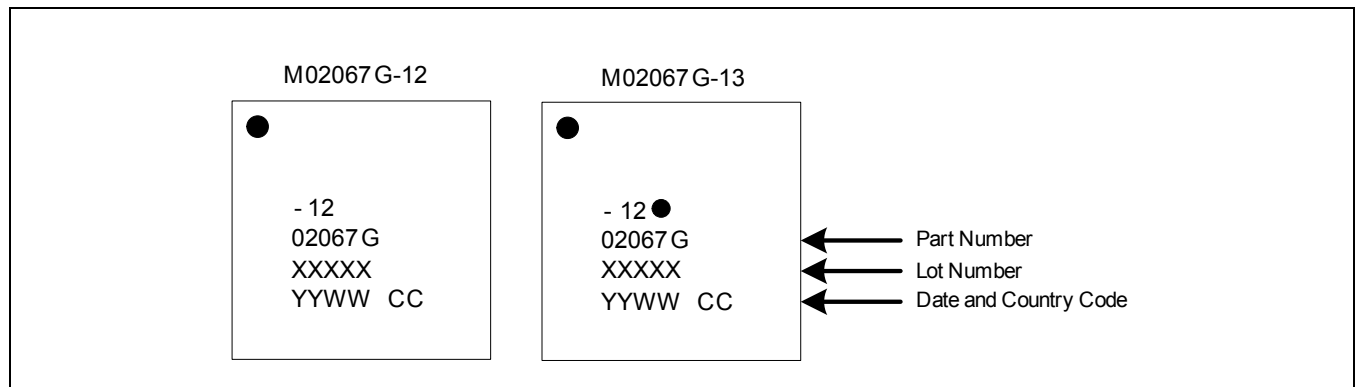

Top View Pin Configuration
 (See [Figure 4-1](#) for detailed drawing)

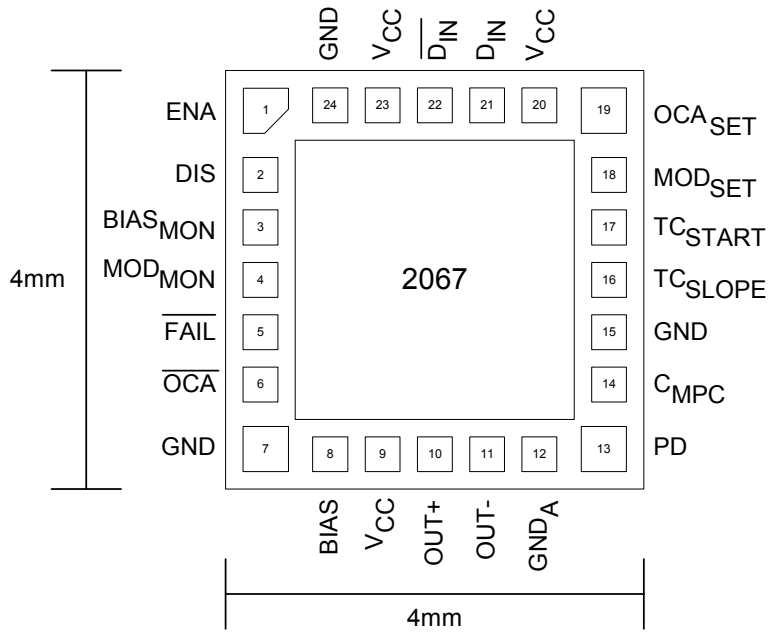



1.0 Product Specification

1.1 Absolute Maximum Ratings

These are the absolute maximum ratings at or beyond which the IC can be expected to fail or be damaged. Reliable operation at these extremes for any length of time is not implied.

Table 1-1. Absolute Maximum Ratings

Parameter	Rating	Units
Power supply (V_{CC-GND})	-0.5 to +6.0	V
Maximum laser bias current	120	mA
Maximum laser modulation current (through OUT+, OUT-)	100	mA
Storage temperature	-65 to +150	°C
Junction temperature (die)	-40 to +120	°C

1.2 Recommended Operating Conditions

Table 1-2. Recommended Operating Conditions

Parameter	Rating	Units
Power supply (V_{CC-GND})	3.3 ± 10%	V
Operating ambient temperature	-40 to +85	°C

1.3 DC Characteristics

Table 1-3. DC Characteristics

Parameter	Conditions	Min	Typ	Max	Units
Supply current	Excluding I _{BIAS} and I _{MOD} but with I _{BIAS} and I _{MOD} set to maximum	-	52	64	mA
Bias current adjust range	Limited by I _{REF} across temperature range	4	-	100	mA
Bias current with output disabled	Tx-Dis = HIGH	-	-	300	µA
Maximum bias current limit	T _A = +85 °C (adjustable)	100 ⁽¹⁾	-	-	mA
Monitor diode reverse bias voltage		2	-	-	V
Monitor diode current adjustment range		40	-	1000	µA
TTL/CMOS input HIGH voltage (enable/disable)		2.0	-	-	V
TTL/CMOS input LOW voltage (enable/disable)		-	-	0.8	V
CMOS output HIGH voltage (Fail,OCA)		2.4	-	-	V
CMOS output LOW voltage (Fail,OCA)		-	-	0.4	V
Differential input impedance	Data and clock inputs	2.5	-	-	kΩ
Common-mode input voltage'		V _{CC} -1.38	-	$\frac{V_{CC} - V_{IN}(Diff)}{4}$	V
Self-biased common mode input voltage	Data and clock inputs	V _{CC} -1.38	-	V _{CC} -0.47	V
Ratio of bias monitoring current, and bias current			55		
Ratio of modulation monitoring current, and modulation current			55		
Tx_Disable negate time ⁽²⁾	C _{MPC} = 3.8 nF		.5	1	ms
Tx_Disable assert time ⁽³⁾				1	µs
Modulation Off Current ⁽⁴⁾	Measured at pin OUT-, temperature at 75 °C			300	µA

V_{CC} = +3.3V ±10%, T_A = -40 °C to +85 °C, unless otherwise noted
Notes:
(1)Condition when pin 19 OCA_{SET} is connected to ground.
(2)Time for optical power to reach 90% of its mean level following negation of Tx_Disable.
(3)Time for optical power to reach 10% of its mean level following assertion of Tx_Disable.
(4)Data input voltage (V_{pin21} – V_{pin22}) > 300 mV, ENA (pin 1) connected to V_{CC}, DIS (pin 2) connected to ground. R_{MODSET} = 5.5 kΩ, resistance to ground at G_{ND}A = 0.35 Ω.

1.4 AC Characteristics

Table 1-4. AC Characteristics

Parameter	Conditions	Min.	Typ.	Max.	Units.
Differential input voltage	$= 2 \times (D_{IN+HIGH} - D_{IN+LOW})$	300	-	1860	mV
Modulation current range		2.5	-	85	mA
Modulation current with output disabled	DIS = HIGH	-	-	300	μA
Programmable range for modulation current temperature coefficient	Adjustable	500	-	10 ⁴	ppm/°C
Programmable temperature at which modulation current TC compensation enables	Programmed by choice of R _{TC SLOPE}	20	-	60	°C
Modulation output rise/fall times	20% to 80% into 25Ω, with matching network	-	-	150	ps
Overshoot of modulation output current	Into 25Ω load, with matching network	-5	-	+5	%
Modulation output Pulse width distortion	Measured using alternating 1-0 pattern	-	-	50	ps
Modulation output deterministic jitter	Peak-to-peak. Measured into 25Ω load using 27 ¹ PRBS at 2.1 Gbps	-	-	50	ps
Notes: VCC = +3.3V ±10%, TA = -40 °C to +85 °C, unless otherwise noted					

1.5 DC Screen

The M02067 is screened under the following conditions.

T_A = 25 °C, V_{CC} = 3.3 V, R_{MODSET} = 8.46 kΩ

Table 1-5. DC Screen

Part Number	Parameter	Production Test Conditions	Screen Limits
M02067G-12	Modulation Current	Measured at pin OUT- Load resistor at OUT- is 24 Ω connected to V _{CC}	41.8 mA min. to 50.8 mA max
M02067G-13	Modulation Current	Measured at pin OUT- Load resistor at OUT- is 24 Ω connected to V _{CC}	41.8 mA min. to 48.0 mA max



2.0 Pin Description

2.1 Pin Descriptions

Table 2-1. Pin Descriptions

Pin Number	Pin Name	Function
1	ENA	Bias and modulation output enable (TTL/CMOS). Logic HIGH for normal operation.
2	DIS	Bias and modulation output disable (TTL/CMOS). Logic LOW for normal operation.
3	BIAS _{MON}	Bias monitor. Connect a resistor between this pin and V _{CC} to monitor bias current. Connect to V _{CC} if not used.
4	MOD _{MON}	Modulation monitor. Connect a resistor between this pin and V _{CC} to monitor modulation current. Connect to V _{CC} if not used.
5	FAIL	Mean power control failure indicator (TTL/CMOS). Goes LOW when control loop is no longer able to maintain constant current at PD.
6	OCA	Over-current alarm (TTL/CMOS). Goes LOW when I _{BIAS} exceeds the preset bias current limit.
7	GND	Ground.
8	BIAS	Laser bias current output.
9	V _{CC}	Power supply.
10	OUT+	Positive modulation current output. Sinks current when D _{IN} is HIGH.
11	OUT-	Negative modulation current output. Sinks current when D _{IN} is HIGH.
12	GND _A	Ground to output stage.
13	PD	Monitor photodiode input. This input is connected to the monitor photodiode anode for automatic power control.
14	C _{MPC}	Mean power control dominant pole capacitor. Connect to V _{CC} via a capacitor.
15	GND	Ground.
16	TC _{SLOPE}	Connecting a resistor between this pin and ground sets the temperature coefficient of I _{MODSET} .
17	TC _{START}	Secondary temperature coefficient of I _{MOD} . A resistor on this pin to ground sets the threshold temperature at which compensation starts.
18	MOD _{SET}	Modulation current set. Connect a resistor between this pin and ground to set.
19	OCA _{SET}	Over-current alarm set. Connect a resistor between this pin and ground to set.
20	V _{CC}	Power supply.
21	D _{IN}	Positive data input (PECL). Self biased.
22	D _{IN}	Negative data input (PECL). Self biased.

Table 2-1. Pin Descriptions (Continued)

Pin Number	Pin Name	Function
23	V _{CC}	Power supply.
24	GND	Ground.
Note: Center pad (pad 25) should be connected to ground.		

3.2 Features

- Rise and fall times <150 ps
- DC or AC-coupled modulation drive
- Independently programmable laser bias and modulation currents
- Bias current to 100 mA and modulation current to 85 mA at $V_{CC} = 3.3V$
- Automatic laser power control, with programmable temperature compensation and 'Slow-Start'
- Bias and modulation current monitors
- Operates with +3.3V supply

3.3 Modulator

The modulator output stage is designed to drive up to 85 mA in either AC-coupled or DC-coupled mode. DC-coupled performance depends on the laser used.

The M02067 modulation output is optimized for driving a 25Ω load; the minimum required voltage at OUT+ and OUT- is 0.6V. To interface with the laser diode, a matching resistor (R_D) is required for impedance matching. An RC shunt network is necessary to compensate for the laser diode parasitic inductance, thereby improving the optical eye. Typical values are $R_{SHUNT} = 51\Omega$, $C_{SHUNT} = 3.3$ pF

Any capacitive loading at the cathode of a laser diode will degrade the optical output performance. An inductor is used to isolate the BIAS pin from the laser cathode.

Figure 3-2 shows the typical I_{MOD} vs R_{MODSET} characteristic.

Figure 3-2. Modulation Current for Given R_{MODSET} Resistor

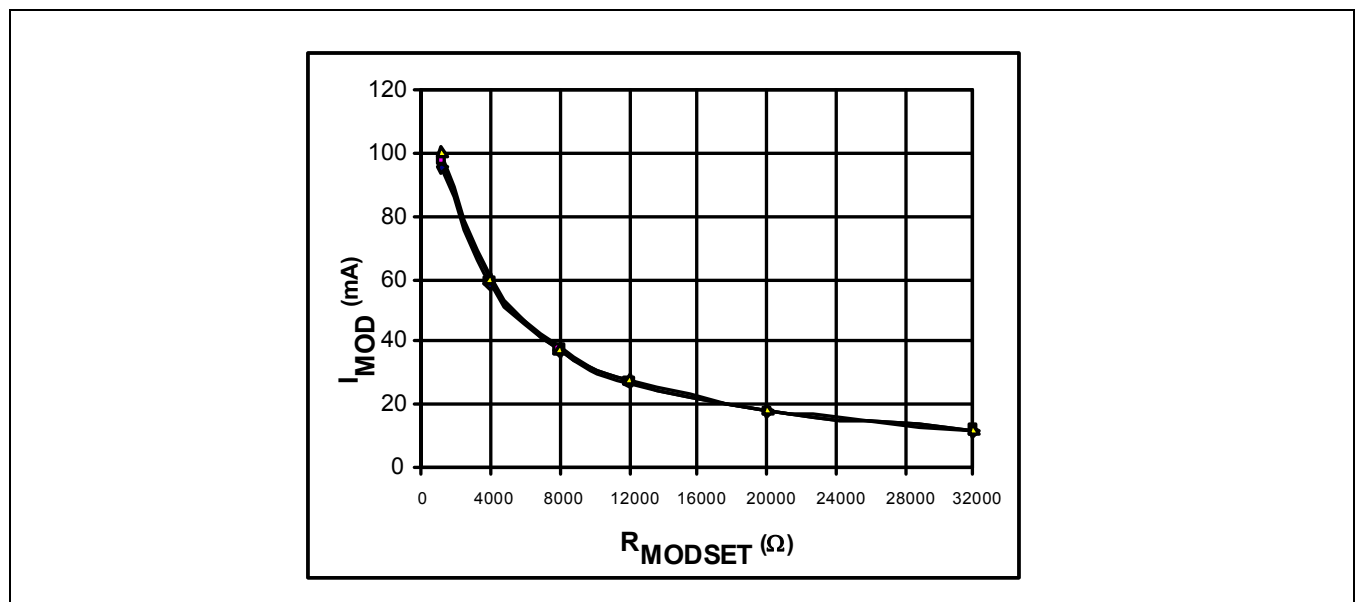

Figure 3-3. Fibre Channel 1.0625 Gbps Electrical Eye Diagram

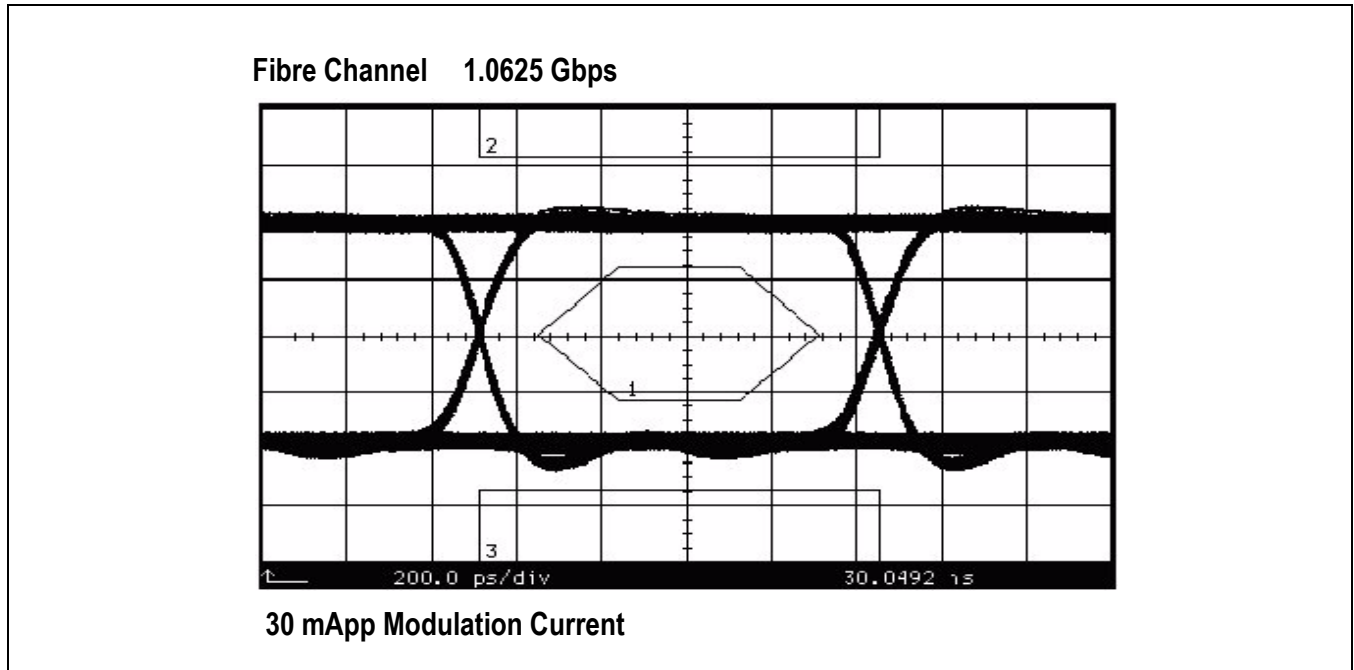

Figure 3-4. Gigabit Ethernet 1.25 Gbps Electrical Eye Diagram

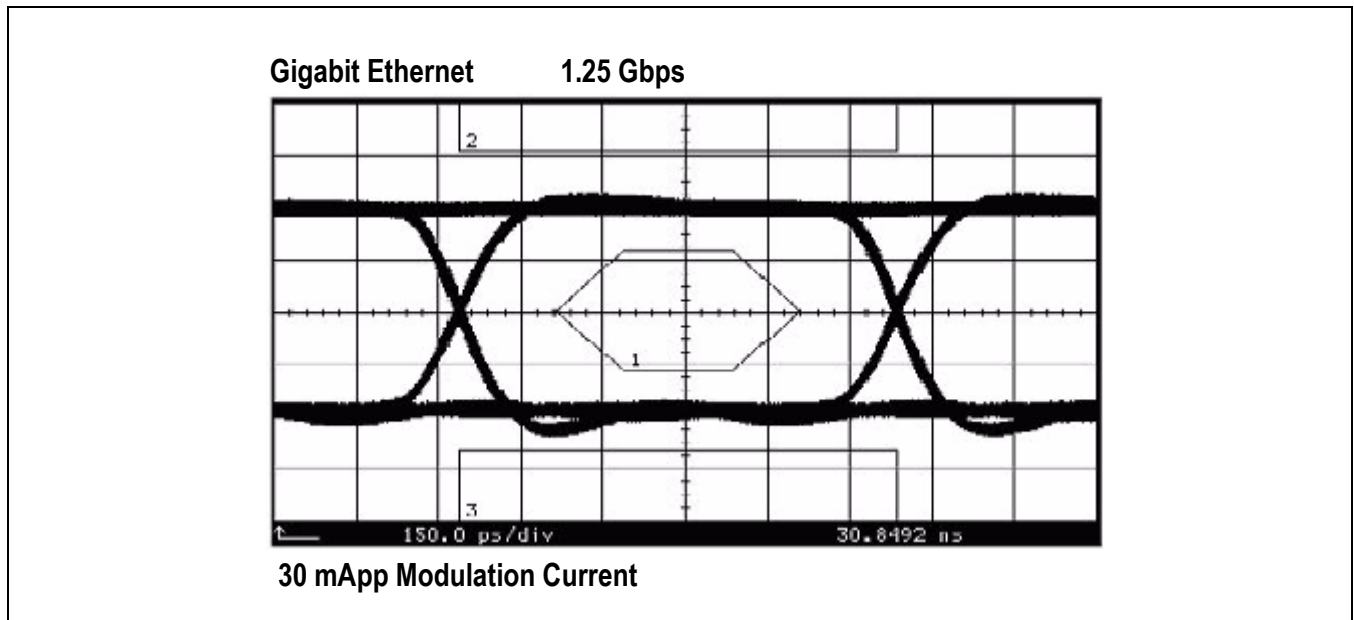
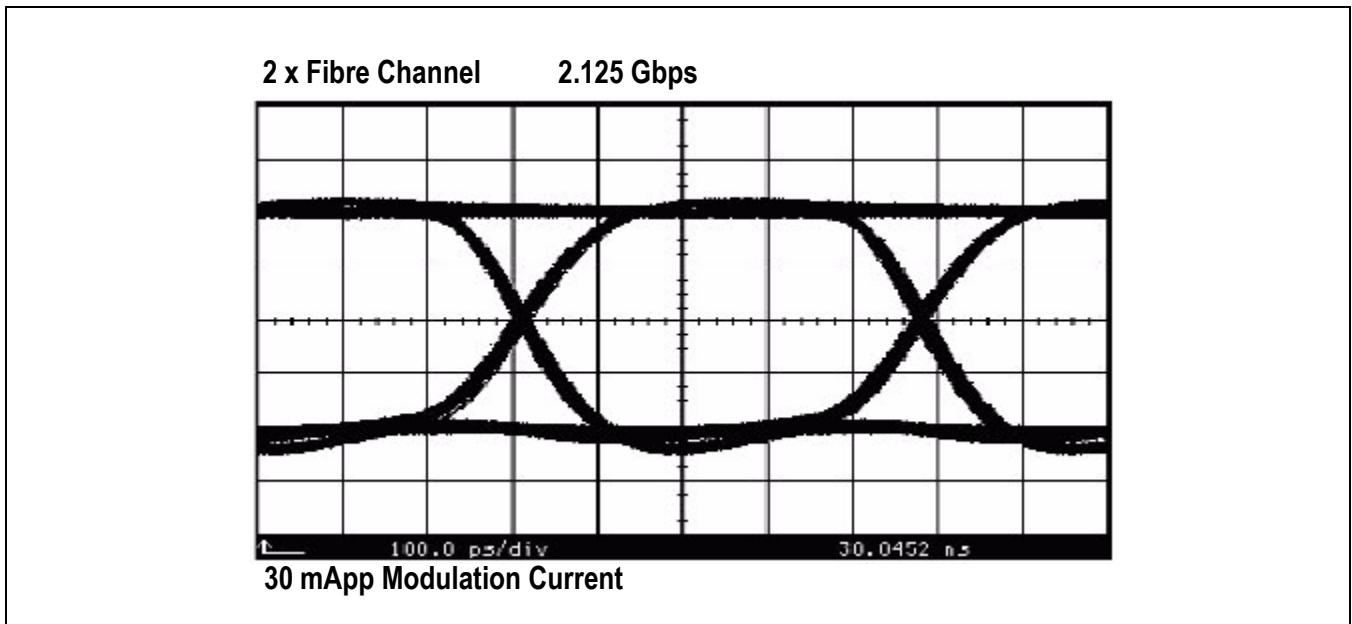

Figure 3-5. 2 x Fibre Channel 2.125 Gbps Electrical Eye Diagram



3.4 Mean Power Control Loop

The M02067 employs a Mean Power Control (MPC) loop to maintain a constant optical output power from the laser across temperature, time and power supply variations. Laser diodes used for communication purposes come with integrated photo-diodes to monitor the output power and provide the feedback for the MPC loop. The MPC loop (or its integrated safety features) cannot be used without this feedback.

The MPC loop adjusts the laser bias current so that the monitor current from the photo-diode is matched to a reference current set by a single external resistor, R_{MPCSET} . The time constant of the MPC loop is determined by C_{MPC} .

Table 3-1. MPC Loop Bandwidth

C_{MPC}	6 dB cutoff frequency
0	17 MHz
1 nF	100 kHz
10 nF	10 kHz
100 nF	1 kHz

(at 6 dB cut off frequency) vs C_{MPC} (for nominal process)

Figure 3-6 shows the bias current vs R_{MPCSET} over the full operating temperature range for a typical laser and monitor photodiode.

Figure 3-6. Bias Current vs. R_{MPCSET}

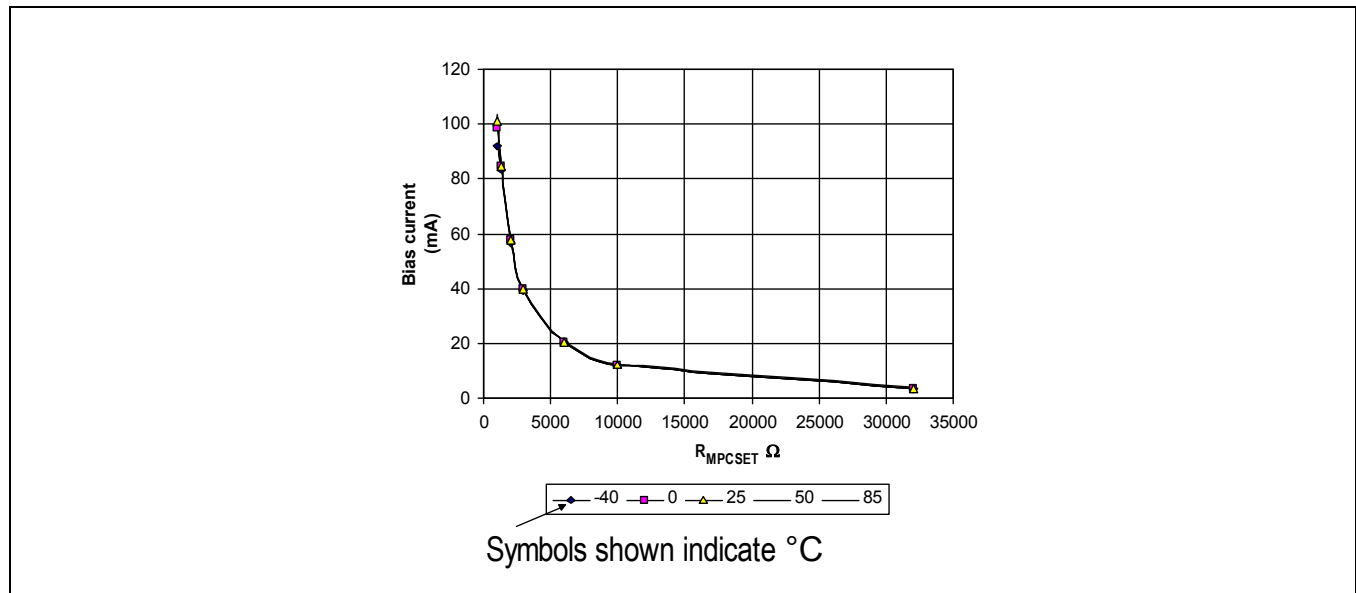

There are two safety features integrated into the MPC loop; an Over-Current Alarm and an MPC loop failure alarm. The Over-Current Alarm (OCA) circuit limits the maximum bias current generated by the M02067. The bias current limit is set by an external resistor to ground, R_{OCA} . When this limit is exceeded the \overline{OCA} pin is asserted LOW. Figure 3-7 shows the maximum bias current limit vs R_{OCA} .

Figure 3-7. Maximum Bias Current vs. R_{OCA}

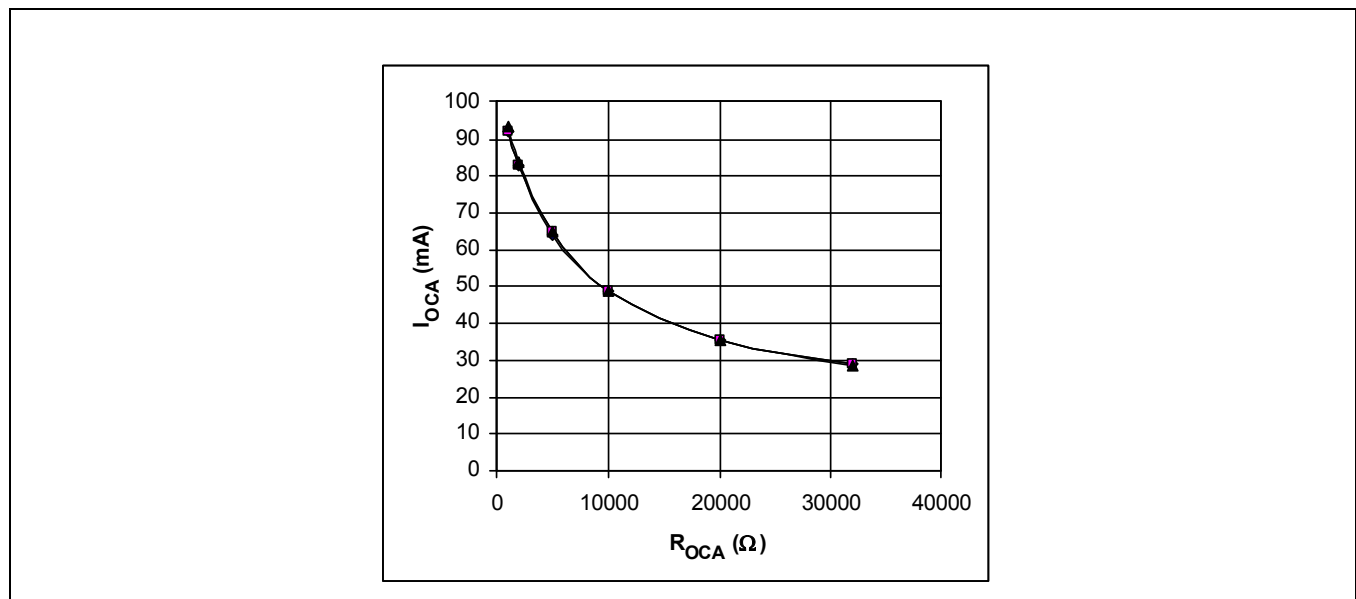

The **MPC loop FAILURE alarm** (FAIL) is generated by the M02067 when the MPC loop can no longer maintain the constant current set by R_{MPCSET} . When the MPC loop failure alarm is triggered the \overline{FAIL} pin is asserted LOW.

3.5 Enable Control

The M02067 incorporates a dual polarity laser enable function with both enable (ENA) and disable (DIS) inputs.

Under normal operating conditions the ENA will be HIGH while DIS is LOW. Should ENA go LOW (or DIS go HIGH) both the bias and modulation currents will be disabled.

Wire OR-ing the OCA and FAIL pins externally and connecting them to the ENA pin will automatically disable the bias and modulation currents when a failure occurs.

3.6 Current Monitors

The M02067 features bias and modulation current monitor outputs. The $BIAS_{MON}$ output sinks a current equal to nominally 1/55 of the laser bias current (I_{BIAS}). The MOD_{MON} output sinks a current equal to nominally 1/55 of the laser modulation current (I_{MOD}). $BIAS_{MON}$ and MOD_{MON} should be connected through a pull-up resistor to V_{CC} . Choose a pull-up resistor value that ensures a voltage at $BIAS_{MON}$ greater than $V_{CC} - 1.6V$ and a voltage at MOD_{MON} greater than $V_{CC} - 1.0V$. These pins should be tied to V_{CC} if not used.

3.7 Slow-Start

For laser safety and reliability, the M02067 incorporates a slow-start circuit that provides a delay of approximately 200 ns before enabling the laser diode.

3.8 Temperature Compensation

The M02067 features built in temperature compensation of the modulation current is set using two external resistors, TC_{SLOPE} and TC_{START} see Figure 3-8.

Current pulled from TC_{SLOPE} adjusts the slope of the temperature compensation whereas current pulled from TC_{START} sets the threshold temperature for the coefficient.

Figure 3-8. Temperature Compensation

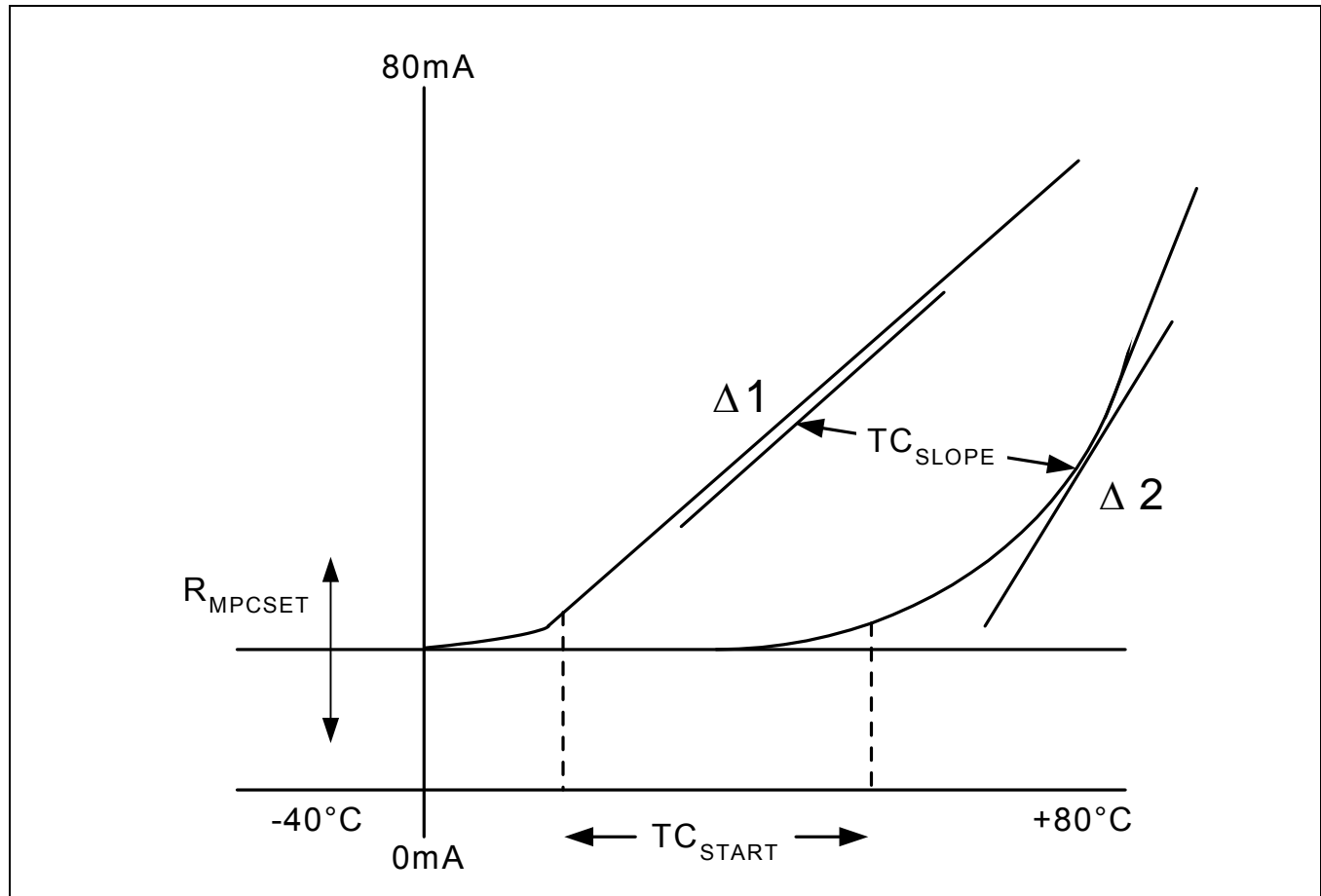

Figures 3-9 through 3-11 show I_{MOD} temperature compensation using a combination of resistor values for RTC_{SLOPE} and RTC_{START} .

Figure 3-9.

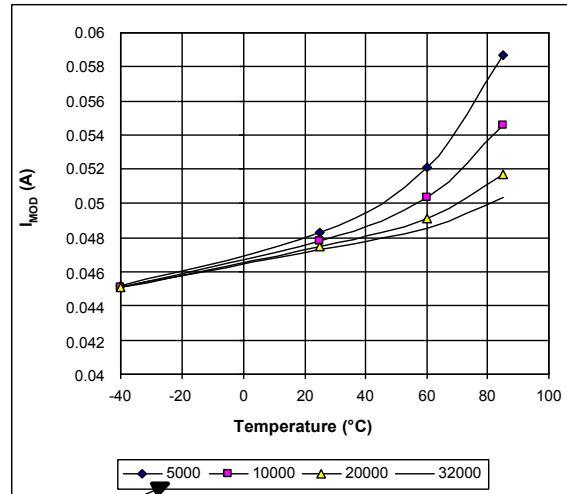

RTC_{SLOPE} - Figures shown are in Ω
 RTC_{START} = 0Ω , V_{CC} = 3.3V

Figure 3-10.

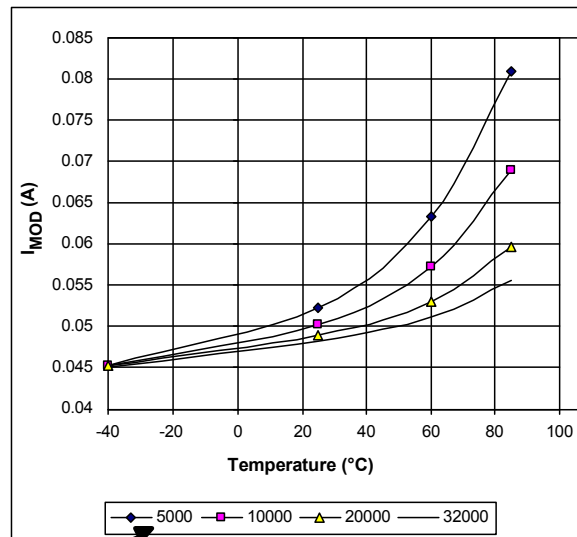

RTC_{SLOPE} - Figures shown are in Ω
 RTC_{START} = 250Ω , V_{CC} = 3.3V

Figure 3-11.

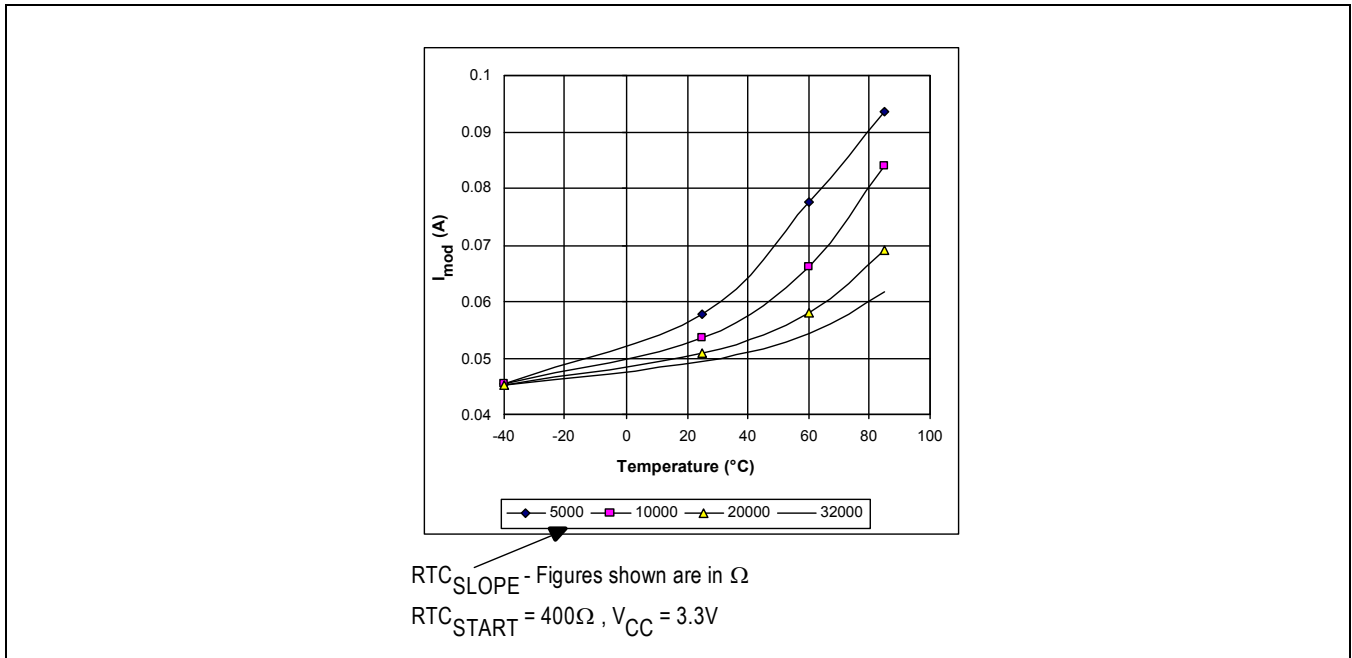

3.9 Laser eye safety

All lasers for commercial and industrial use, including lasers for optical communications are classified for eye safety considerations in IEC 60825-1, CDRH and other national standards.

NOTE:

The M02067 alone does NOT ensure that any application within which it is used will be fully compliant with the relevant eye-safety requirements. It remains the sole responsibility of the user of this component to ensure that the application within which the M02067 is used meets all eye-safety requirements.



4.0 Packaging Specification

4.1 Packaging Specification

Table 4-1. Packaging Specifications

Parameter	Value
Assembly location	ASE Malaysia
X dimension (mm)	4.00 ± 0.10
Y dimension (mm)	4.00 ± 0.10
Z dimension (mm)	0.90 ± 0.10
Pad standoff (mm)	0.02 + 0.03, -0.02
Terminal finish	100% Matte SN
Marking	Laser

Figure 4-1. M02067 QFN24 Package Outline Drawing

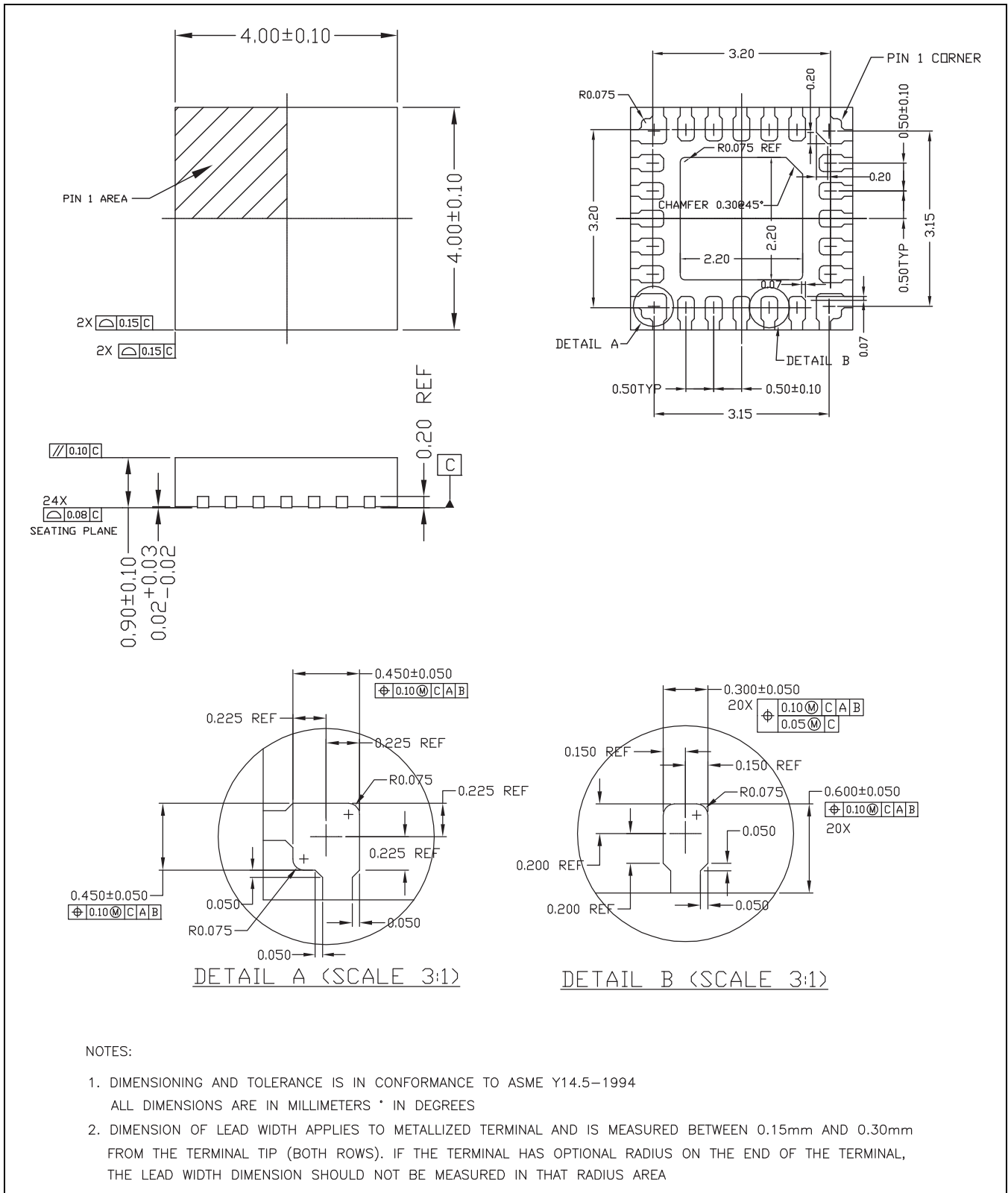

www.mindspeed.com

General Information:
Telephone: (949) 579-3000
Headquarters - Newport Beach
4000 MacArthur Blvd., East Tower
Newport Beach, CA 92660

© 2010 - 2011 Mindspeed Technologies®, Inc. All rights reserved.

Information in this document is provided in connection with Mindspeed Technologies® ("Mindspeed®") products. These materials are provided by Mindspeed as a service to its customers and may be used for informational purposes only. Except as provided in Mindspeed's Terms and Conditions of Sale for such products or in any separate agreement related to this document, Mindspeed assumes no liability whatsoever. Mindspeed assumes no responsibility for errors or omissions in these materials. Mindspeed may make changes to specifications and product descriptions at any time, without notice. Mindspeed makes no commitment to update the information and shall have no responsibility whatsoever for conflicts or incompatibilities arising from future changes to its specifications and product descriptions. No license, express or implied, by estoppel or otherwise, to any intellectual property rights is granted by this document.

THESE MATERIALS ARE PROVIDED "AS IS" WITHOUT WARRANTY OF ANY KIND, EITHER EXPRESS OR IMPLIED, RELATING TO SALE AND/OR USE OF MINDSPEED PRODUCTS INCLUDING LIABILITY OR WARRANTIES RELATING TO FITNESS FOR A PARTICULAR PURPOSE, CONSEQUENTIAL OR INCIDENTAL DAMAGES, MERCHANTABILITY, OR INFRINGEMENT OF ANY PATENT, COPYRIGHT OR OTHER INTELLECTUAL PROPERTY RIGHT. MINDSPEED FURTHER DOES NOT WARRANT THE ACCURACY OR COMPLETENESS OF THE INFORMATION, TEXT, GRAPHICS OR OTHER ITEMS CONTAINED WITHIN THESE MATERIALS. MINDSPEED SHALL NOT BE LIABLE FOR ANY SPECIAL, INDIRECT, INCIDENTAL, OR CONSEQUENTIAL DAMAGES, INCLUDING WITHOUT LIMITATION, LOST REVENUES OR LOST PROFITS, WHICH MAY RESULT FROM THE USE OF THESE MATERIALS.

Mindspeed products are not intended for use in medical, lifesaving or life sustaining applications. Mindspeed customers using or selling Mindspeed products for use in such applications do so at their own risk and agree to fully indemnify Mindspeed for any damages resulting from such improper use or sale.