

SMD Emitter Component

OP181

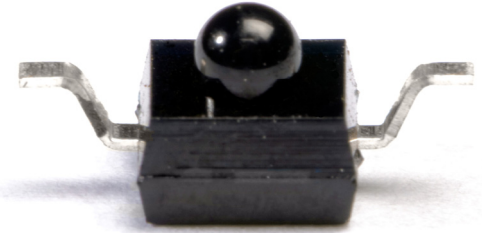

Features:

- 940nm Wavelength
- Up to 256kbps Operation
- Compliant with Smart Power Meter Standard ANSI C12.18
- Lensed for Maximum Performance
- Reverse Gull Wing Design
- Compatible with OPL6000 Receiver Component

Description:

The **OP181** is a surface mount emitter component incorporating a high power 940nm LED. The LED die is lead frame mounted and overmolded, incorporating a lens to achieve excellent beam angle characteristics. The final product provides superior output irradiance at low drive currents. While this part has been designed specifically for the smart power meter industry, other applications are certainly possible.

Applications:

- Smart power meter optical port
- Over the air communications

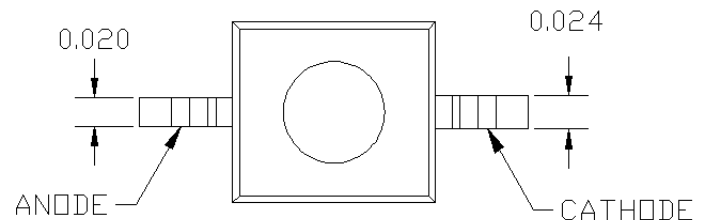
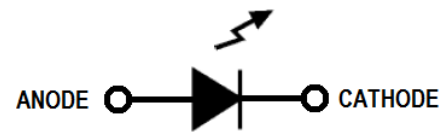
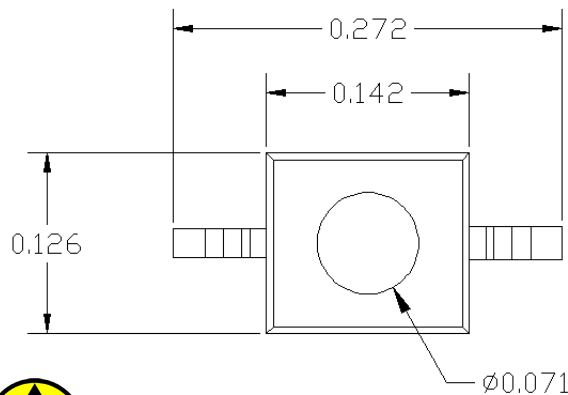

ESD
(Human Body Model)



MOISTURE
(Level-4)



Pb-Free
(RoHS)

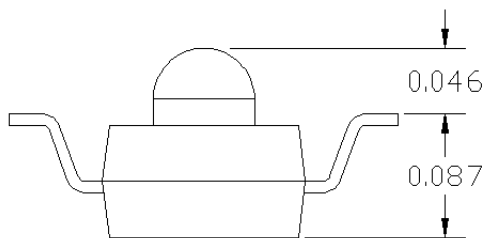

Note: The cathode lead is the wider of the two leads as indicated above but also has red strip indicator on the bottom of the lead.

Dimensions are ± 0.005 unless otherwise specified

General Note

TT Electronics reserves the right to make changes in product specification without notice or liability. All information is subject to TT Electronics' own data and is considered accurate at time of going to print.



1645 Wallace Drive, Carrollton, TX 75006 | Ph: +1 972 323 2200
www.optekinc.com | www.ttelectronics.com

Electrical Specifications

Absolute Maximum Ratings ($T_A = 25^\circ\text{C}$ unless otherwise noted)

Storage Temperature Range	-55° C to +100° C
Operating Temperature Range	-40° C to +85° C
Reverse Voltage	5 V
Continuous Forward Current ⁽¹⁾	50 mA
Peak Forward Current (1 μs pulse width, 10% duty cycle)	1 A
Power Dissipation ⁽²⁾	130 mW
Solder Reflow Temperature ⁽³⁾	260° C

Electrical Characteristics ($T_A = 25^\circ\text{C}$ unless otherwise noted)

SYMBOL	PARAMETER	MIN	TYP	MAX	UNITS	TEST CONDITIONS
P_O	Total Output Power	0.4	1.0		mW	$I_F = 20\text{ mA}$
λ_P	Wavelength at Peak Emission	-	940	-	nm	
V_F	Forward Voltage	-	1.55	1.65	V	$I_F = 20\text{ mA}$
I_R	Reverse Leakage Current	-	-	10	μA	$V_R = 5\text{V}$
θ_{HP}	Emission Angle at Half Power Points	-	10	15	Degree	
t_r, t_f	Rise Time, Fall Time	-	0.5	1	μs	$f = 1\text{ kHz}, 10\% - 90\%, I_{F(PK)} = 100\text{ mA}$

Notes:

- Derate 0.66 mA/°C above 25°C.
- Derate 1.73 mW/°C above 25°C.
- Solder time less than 5 seconds at temperature extreme. Solder time within 5° of peak temperature is 20 to 40 seconds.

Recommended PCB Layout

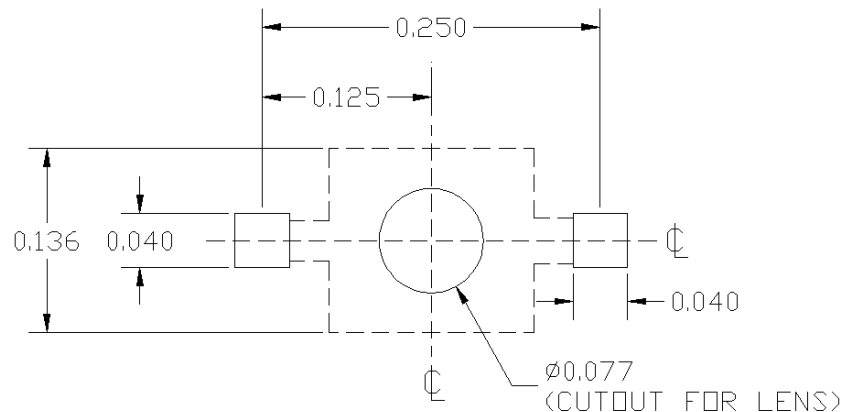

General Note

TT Electronics reserves the right to make changes in product specification without notice or liability. All information is subject to TT Electronics' own data and is considered accurate at time of going to print.

Performance

Forward Voltage vs Forward Current vs Temperature

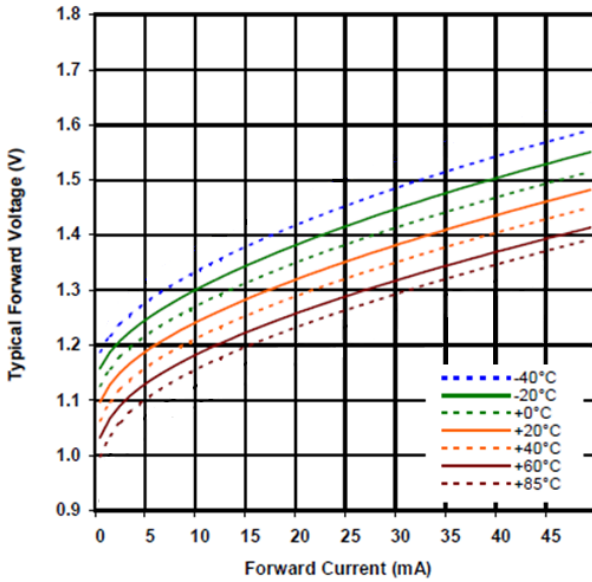

Optical Power vs I_f vs Temp

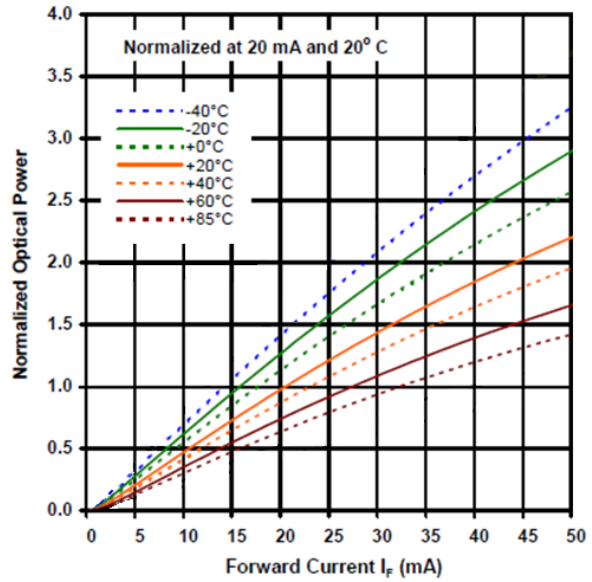

OP181 Beam Angle

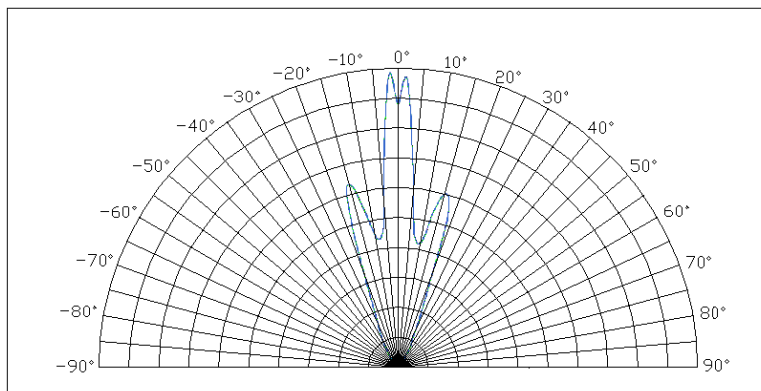
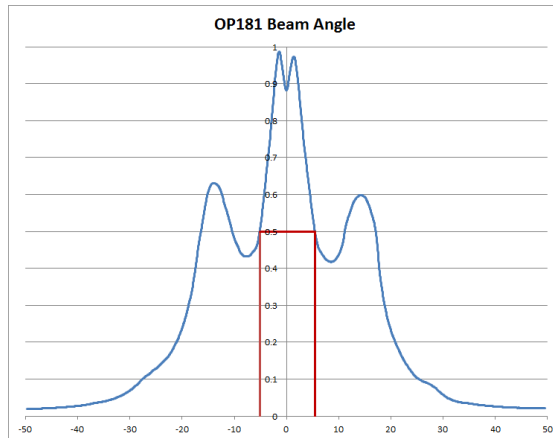

General Note

TT Electronics reserves the right to make changes in product specification without notice or liability. All information is subject to TT Electronics' own data and is considered accurate at time of going to print.



1645 Wallace Drive, Carrollton, TX 75006 | Ph: +1 972 323 2200
www.optekinc.com | www.ttelectronics.com

Packaging

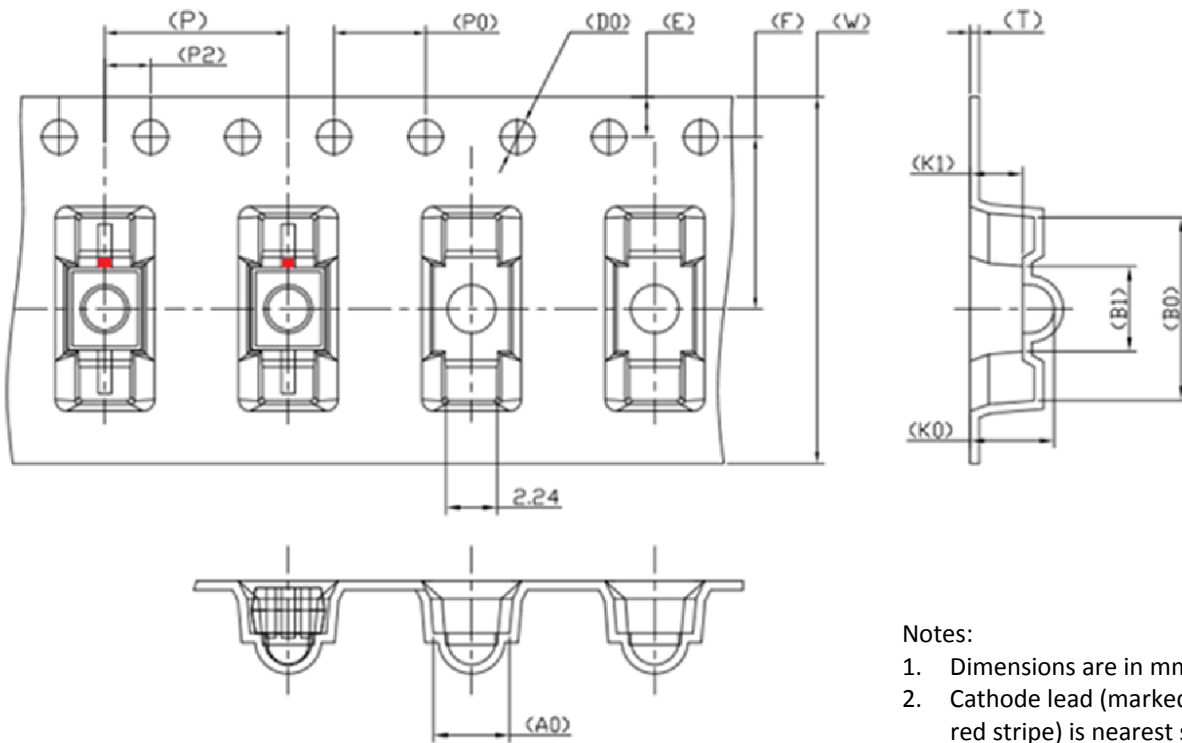

Notes:

1. Dimensions are in mm.
2. Cathode lead (marked with red stripe) is nearest sprocket holes.

W	16.00±0.30	P	8.00±0.10	A0	3.33±0.10	B0	8.00±0.10
E	1.75±0.10	P0	4.00±0.10	K0	3.66±0.10	B1	3.73±0.10
F	7.50±0.10	P2	2.00±0.10	K1	2.30±0.10		
T	0.40±0.05	D0	∅1.50±0.10				

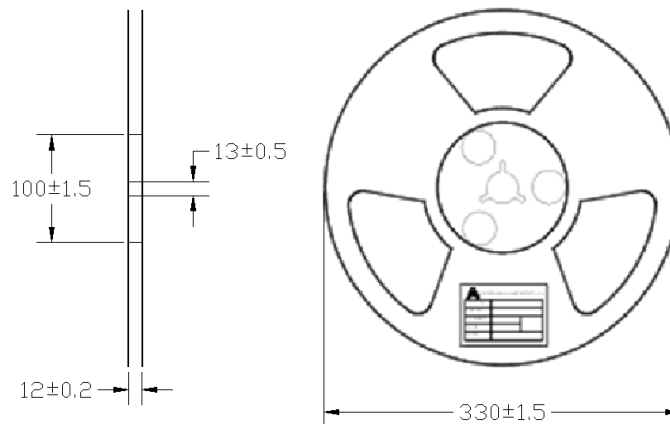

General Note

TT Electronics reserves the right to make changes in product specification without notice or liability. All information is subject to TT Electronics' own data and is considered accurate at time of going to print.