

### FEATURES

- Very Low-Noise,  $5 \text{ nV}/\sqrt{\text{Hz}}$  @ 1 kHz Max
- Excellent Input Offset Voltage, 0.4 mV Max
- Low Offset Voltage Drift,  $2 \mu\text{V}/^\circ\text{C}$  Max
- Very High Gain, 1000 V/mV Min
- Outstanding CMR, 110 dB Min
- Slew Rate,  $2 \text{ V}/\mu\text{s}$  Typ
- Gain-Bandwidth Product, 6 MHz Typ
- Industry Standard Quad Pinouts
- Available in Die Form

### GENERAL DESCRIPTION

The OP470 is a high-performance monolithic quad operational amplifier with exceptionally low voltage noise,  $5 \text{ nV}/\sqrt{\text{Hz}}$  at 1 kHz max, offering comparable performance to ADI's industry standard OP27.

The OP470 features an input offset voltage below 0.4 mV, excellent for a quad op amp, and an offset drift under  $2 \mu\text{V}/^\circ\text{C}$ , guaranteed over the full military temperature range. Open loop gain of the OP470 is over 1,000,000 into a 10 k $\Omega$  load ensuring excellent gain accuracy and linearity, even in high gain applications. Input bias current is under 25 nA, which reduces errors due to signal source resistance. The OP470's CMR of over 110 dB and PSRR of less than  $1.8 \mu\text{V}/\text{V}$  significantly reduce errors due to ground noise and power supply fluctuations. Power consumption of the quad OP470 is half that of four OP27s, a significant advantage for power conscious applications. The OP470 is unity-gain stable with a gain bandwidth product of 6 MHz and a slew rate of  $2 \text{ V}/\mu\text{s}$ .

### PIN CONNECTIONS

14-Lead Hermetic DIP  
(Y-Suffix)

14-Lead Plastic DIP  
(P-Suffix)

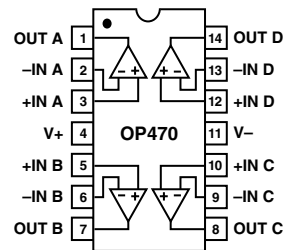

16-Lead SOIC Package  
(S-Suffix)

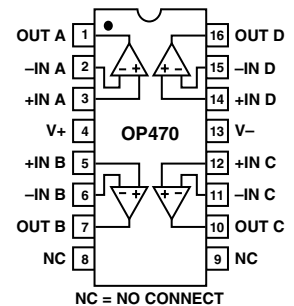

The OP470 offers excellent amplifier matching which is important for applications such as multiple gain blocks, low noise instrumentation amplifiers, quad buffers, and low noise active filters.

The OP470 conforms to the industry standard 14-lead DIP pinout. It is pin compatible with the LM148/149, HA4741, HA5104, and RM4156 quad op amps and can be used to upgrade systems using these devices.

For higher speed applications, the OP471, with a slew rate of  $8 \text{ V}/\mu\text{s}$ , is recommended.

### SIMPLIFIED SCHEMATIC

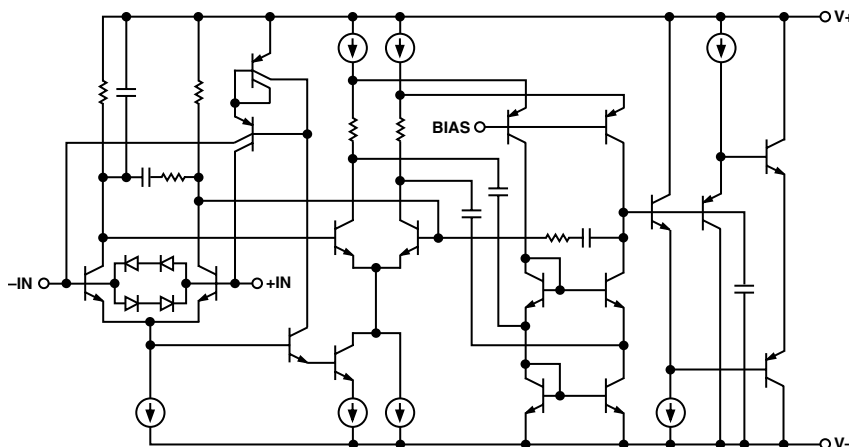

REV. B

Information furnished by Analog Devices is believed to be accurate and reliable. However, no responsibility is assumed by Analog Devices for its use, nor for any infringements of patents or other rights of third parties that may result from its use. No license is granted by implication or otherwise under any patent or patent rights of Analog Devices.

# OP470—SPECIFICATIONS

## ELECTRICAL CHARACTERISTICS (at $V_S = \pm 15\text{ V}$ , $T_A = 25^\circ\text{C}$ , unless otherwise noted.)

Parameter	Symbol	Conditions	OP470A/E			OP470F			OP470G			Unit
			Min	Typ	Max	Min	Typ	Max	Min	Typ	Max	
INPUT OFFSET VOLTAGE	$V_{OS}$		0.1	0.4		0.2	0.8		0.4	1.0	mV	
INPUT OFFSET CURRENT	$I_{OS}$	$V_{CM} = 0\text{ V}$	3	10		6	20		12	30	nA	
INPUT BIAS CURRENT	$I_B$	$V_{CM} = 0\text{ V}$	6	25		15	50		25	60	nA	
INPUT NOISE VOLTAGE	$e_{np-p}$	0.1 Hz to 10 Hz (Note 1)	80	200		80	200		80	200	nV <sub>p-p</sub>	
INPUT NOISE Voltage Density	$e_n$	$f_O = 10\text{ Hz}$ $f_O = 100\text{ Hz}$ $f_O = 1\text{ kHz}$ (Note 2)	3.8 3.3 3.2	6.5 5.5 5.0		3.8 3.3 3.2	6.5 5.5 5.0		3.8 3.3 3.2	6.5 5.5 5.0	nV $\sqrt{\text{Hz}}$	
INPUT NOISE Current Density	$i_n$	$f_O = 10\text{ Hz}$ $f_O = 100\text{ Hz}$ $f_O = 1\text{ kHz}$	1.7 0.7 0.4			1.7 0.7 0.4			1.7 0.7 0.4		pA $\sqrt{\text{Hz}}$	
LARGE-SIGNAL Voltage Gain	$A_{VO}$	$V = \pm 10\text{ V}$ $R_L = 10\text{ k}\Omega$ $R_L = 2\text{ k}\Omega$	1000 500	2300 1200		800 400	1700 900		800 400	1700 900	V/mV	
INPUT VOLTAGE RANGE	IVR	(Note 3)	$\pm 11$	$\pm 12$		$\pm 11$	$\pm 12$		$\pm 11$	$\pm 12$	V	
OUTPUT VOLTAGE SWING	$V_O$	$R_L \geq 2\text{ k}\Omega$	$\pm 12$	$\pm 13$		$\pm 12$	$\pm 13$		$\pm 12$	$\pm 13$	V	
COMMON-MODE REJECTION	CMR	$V_{CM} = \pm 11\text{ V}$	110	125		100	120		100	120	dB	
POWER SUPPLY REJECTION RATIO	PSRR	$V_S = \pm 4.5\text{ V to } \pm 18\text{ V}$	0.56	1.8		1.0	5.6		1.0	5.6	$\mu\text{V/V}$	
SLEW RATE	SR		1.4	2		1.4	2		1.4	2	V/ $\mu\text{s}$	
SUPPLY CURRENT (All Amplifiers)	$I_{SY}$	No Load	9	11		9	11		9	11	mA	
GAIN BANDWIDTH PRODUCT	GBW	$A_V = 10$	6			6			6		MHz	
CHANNEL SEPARATION	CS	$V_O = 20\text{ V}_{p-p}$ $f_O = 10\text{ Hz}$ (Note 1)	125	155		125	155		125	155	dB	
INPUT CAPACITANCE	$C_{IN}$		2			2			2		pF	
INPUT RESISTANCE Differential-Mode	$R_{IN}$		0.4			0.4			0.4		M $\Omega$	
INPUT RESISTANCE Common-Mode	$R_{INCM}$		11			11			11		G $\Omega$	
SETTLING TIME	$t_S$	$A_V = 1$ to 0.1% to 0.01%	5.5 6.0			5.5 6.0			5.5 6.0		$\mu\text{s}$	

### NOTES

<sup>1</sup>Guaranteed but not 100% tested

<sup>2</sup>Sample tested

<sup>3</sup>Guaranteed by CMR test

**ELECTRICAL CHARACTERISTICS** (at  $V_S = \pm 15\text{ V}$ ,  $-55^\circ\text{C} \leq T_A \leq 125^\circ\text{C}$  for OP470A, unless otherwise noted.)

Parameter	Symbol	Conditions	OP470A			Unit
			Min	Typ	Max	
INPUT OFFSET VOLTAGE	$V_{OS}$			0.14	0.6	mV
AVERAGE INPUT Offset Voltage Drift	$TCV_{OS}$			0.4	2	$\mu\text{V}/^\circ\text{C}$
INPUT OFFSET CURRENT	$I_{OS}$	$V_{CM} = 0\text{ V}$		5	20	nA
INPUT BIAS CURRENT	$I_B$	$V_{CM} = 0\text{ V}$		15	20	nA
LARGE-SIGNAL Voltage Gain	$A_{VO}$	$V_O = \pm 10\text{ V}$ $R_L = 10\text{ k}\Omega$ $R_L = 2\text{ k}\Omega$	750 400	1600 800		V/mV
INPUT VOLTAGE RANGE*	IVR		$\pm 11$	$\pm 12$		V
OUTPUT VOLTAGE SWING	$V_O$	$R_L \geq 2\text{ k}\Omega$	$\pm 12$	$\pm 13$		V
COMMON-MODE REJECTION	CMR	$V_{CM} = \pm 11\text{ V}$	100	120		dB
POWER SUPPLY REJECTION RATIO	PSRR	$V_S = \pm 4.5\text{ V to } \pm 18\text{ V}$		1.0	5.6	$\mu\text{V}/\text{V}$
SUPPLY CURRENT (All Amplifiers)	$I_{SY}$	No Load	—	9.2	11	mA

NOTE

\*Guaranteed by CMR test

**ELECTRICAL CHARACTERISTICS** (at  $V_S = \pm 15\text{ V}$ ,  $-25^\circ\text{C} \leq T_A \leq 85^\circ\text{C}$  for OP470E/OP470EF,  $-40^\circ\text{C} \leq T_A \leq 85^\circ\text{C}$  for OP470G, unless otherwise noted.)

Parameter	Symbol	Conditions	OP470E			OP470F			OP470G			Unit
			Min	Typ	Max	Min	Typ	Max	Min	Typ	Max	
INPUT OFFSET VOLTAGE	$V_{OS}$		0.12	0.5		0.24	1.0		0.5	1.5	mV	
AVERAGE INPUT Offset Voltage Drift	$TCV_{OS}$		0.4	2		0.6	4		2		$\mu\text{V}/^\circ\text{C}$	
INPUT OFFSET CURRENT	$I_{OS}$	$V_{CM} = 0\text{ V}$	4	20		7	40		20	50	nA	
INPUT BIAS CURRENT	$I_B$	$V_{CM} = 0\text{ V}$	11	50		20	70		40	75	nA	
LARGE-SIGNAL Voltage Gain	$A_{VO}$	$V_O = \pm 10\text{ V}$ $R_L = 10\text{ k}\Omega$ $R_L = 2\text{ k}\Omega$	800 400	1800 900		600 300	1400 700		600 300	1500 800	V/mV	
INPUT VOLTAGE RANGE*	IVR		$\pm 11$	$\pm 12$		$\pm 11$	$\pm 12$		$\pm 11$	$\pm 12$	V	
OUTPUT VOLTAGE SWING	$V_O$	$R_L \geq 2\text{ k}\Omega$	$\pm 12$	$\pm 13$		$\pm 12$	$\pm 13$		$\pm 12$	$\pm 13$	V	
COMMON-MODE REJECTION	CMR	$V_{CM} = \pm 11\text{ V}$	100	120		90	115		90	110	dB	
POWER SUPPLY REJECTION RATIO	PSRR	$V_S = \pm 4.5\text{ V to } \pm 18\text{ V}$		0.7	5.6		1.8	10		1.8	10	$\mu\text{V}/\text{V}$
SUPPLY CURRENT (All Amplifiers)	$I_{SY}$	No Load	—	9.2	11	—	9.2	11	—	9.3	11	mA

NOTE

\*Guaranteed by CMR test

# OP470—SPECIFICATIONS

## WAFER TEST LIMITS (at $V_S = \pm 15$ V, 25°C, unless otherwise noted.)

Parameter	Symbol	Conditions	OP470GBC Limit	Unit
INPUT OFFSET VOLTAGE	$V_{OS}$		0.8	mV Max
INPUT OFFSET CURRENT	$I_{OS}$	$V_{CM} = 0$ V	20	nA Max
INPUT BIAS CURRENT	$I_B$	$V_{CM} = 0$ V	50	nA Min
LARGE-SIGNAL Voltage Gain	$A_{VO}$	$V_O = \pm 10$ V $R_L = 10$ k $\Omega$ $R_L = 2$ k $\Omega$	800 400	V/mV Min
INPUT VOLTAGE RANGE*	IVR		$\pm 11$	V Min
OUTPUT VOLTAGE SWING	$V_O$	$R_L \geq 2$ k $\Omega$	$\pm 12$	V Min
COMMON-MODE REJECTION	CMR	$V_{CM} = \pm 11$ V	100	dB
POWER SUPPLY REJECTION RATIO	PSRR	$V_S = \pm 4.5$ V to $\pm 18$ V	5.6	$\mu$ V/V Max
SUPPLY CURRENT (All Amplifiers)	$I_{SY}$	No Load	11	mA Max

### NOTE

\*Guaranteed by CMR test

Electrical tests are performed at wafer probe to the limits shown. Due to variations in assembly methods and normal yield loss, yield after packaging is not guaranteed for standard product dice. Consult factory to negotiate specifications based on dice lot qualification through sample lot assembly and testing.

# OP470

## ABSOLUTE MAXIMUM RATINGS<sup>1</sup>

Supply Voltage	±18 V
Differential Input Voltage <sup>2</sup>	±1.0 V
Differential Input Current <sup>2</sup>	±25 mA
Input Voltage	Supply Voltage
Output Short-Circuit Duration	Continuous
Storage Temperature Range	
P, Y Package	-65°C to +150°C
Lead Temperature Range (Soldering 60 sec)	300°C
Junction Temperature (T <sub>j</sub> )	-65°C to +150°C
Operating Temperature Range	
OP470A	-55°C to +125°C
OP470E, OP470F	-25°C to +85°C
OP470G	-40°C to +85°C

## ORDERING GUIDE

T <sub>A</sub> = 25°C V <sub>OS max</sub> (μV)	Package Options		Operating Temperature Range
	Cerdip 14-Pin	Plastic	
400			MIL
400	OP470AY*		MIL
400	OP470EY		IND
800	OP470FY*		IND
1000		OP470GP	XIND
1000		OP470GS	XIND

\*Not for new design; obsolete April 2002.

For military processed devices, please refer to the standard Microcircuit Drawing (SMD) available at [www.dscc.dla.mil/programs/milspec/default.asp](http://www.dscc.dla.mil/programs/milspec/default.asp)

SMD Part Number	ADI Equivalent
59628856501CA	OP470AYMDA
596288565012A	OP470ARCMDA
596288565013A*	OP470ATCMDA

\*Not for new designs; obsolete April 2002.

Package Type	θ <sub>JA</sub> <sup>3</sup>	θ <sub>JC</sub>	Unit
14-Lead Hermetic DIP(Y)	94	10	°C/W
14-Lead Plastic DIP(P)	76	33	°C/W
16-Lead SOIC (S)	88	23	°C/W

## NOTES

<sup>1</sup>Absolute Maximum Ratings apply to both DICE and packaged parts, unless otherwise noted.

<sup>2</sup>The OP470's inputs are protected by back-to-back diodes. Current limiting resistors are not used in order to achieve low noise performance. If differential voltage exceeds ±1.0 V, the input current should be limited to ±25 mA.

<sup>3</sup>θ<sub>JA</sub> is specified for worst case mounting conditions, i.e., θ<sub>JA</sub> is specified for device in socket for TO, CerDIP, PDIP, packages; θ<sub>JA</sub> is specified for device soldered to printed circuit board for SOIC packages.

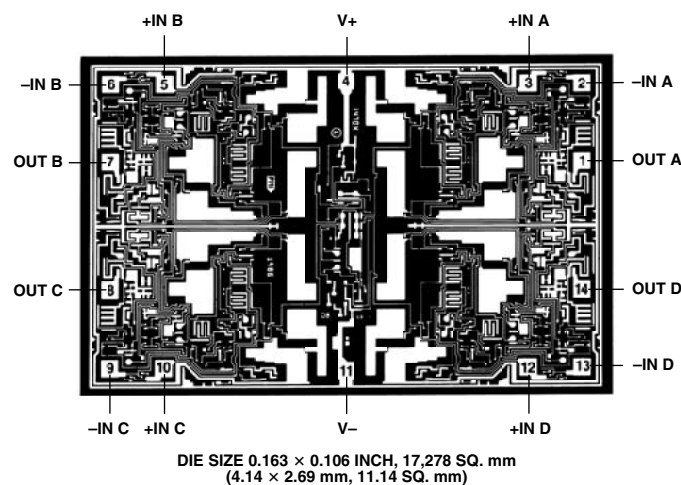

Figure 1. Dice Characteristics

## CAUTION

ESD (electrostatic discharge) sensitive device. Electrostatic charges as high as 4000 V readily accumulate on the human body and test equipment and can discharge without detection. Although the OP470 features proprietary ESD protection circuitry, permanent damage may occur on devices subjected to high energy electrostatic discharges. Therefore, proper ESD precautions are recommended to avoid performance degradation or loss of functionality.



# OP470—Typical Performance Characteristics

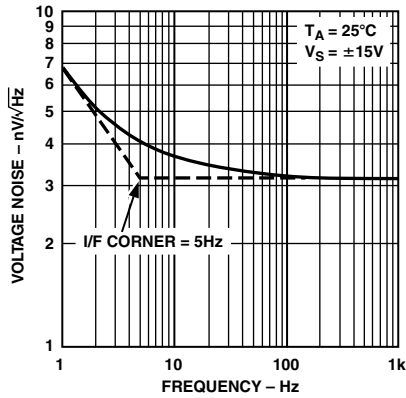

TPC 1. Voltage Noise Density vs. Frequency

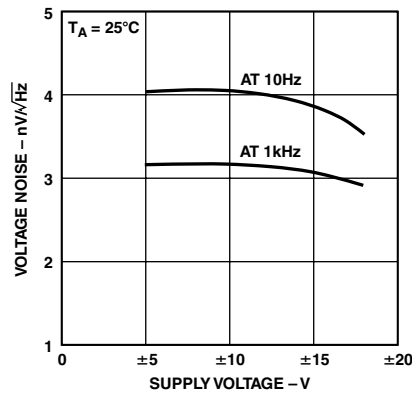

TPC 2. Voltage Noise Density vs. Supply Voltage

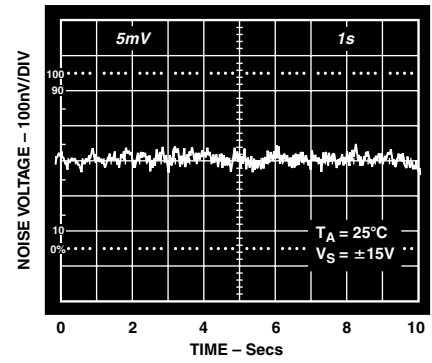

TPC 3. 0.1 Hz to 10 Hz Noise

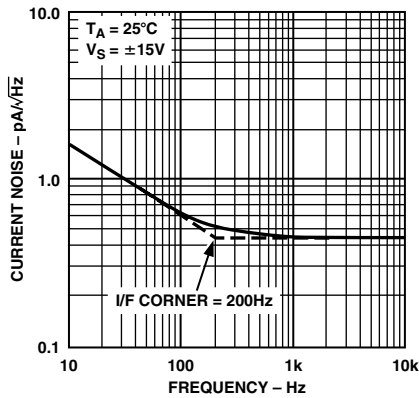

TPC 4. Current Noise Density vs. Frequency

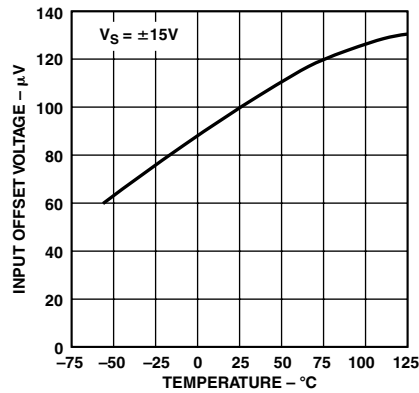

TPC 5. Input Offset Voltage vs. Temperature

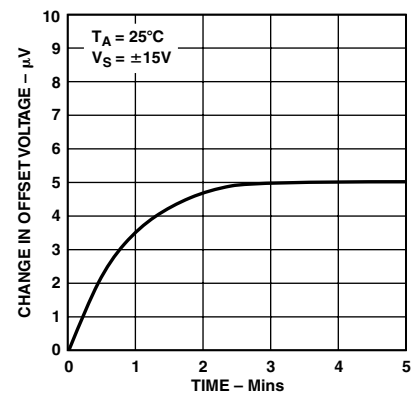

TPC 6. Warm-Up Offset Voltage Drift

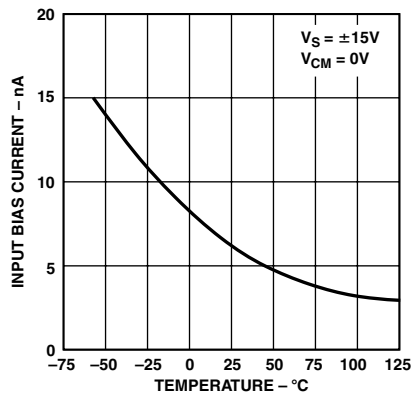

TPC 7. Input Bias Current vs. Temperature

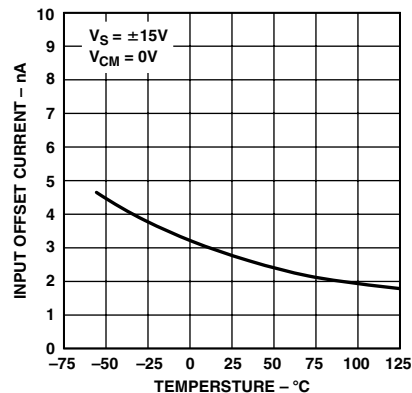

TPC 8. Input Offset Current vs. Temperature

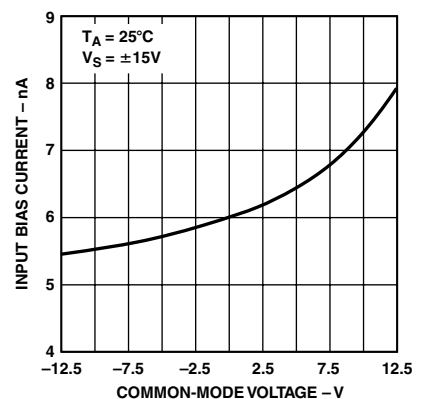

TPC 9. Input Bias Current vs. Common-Mode Voltage

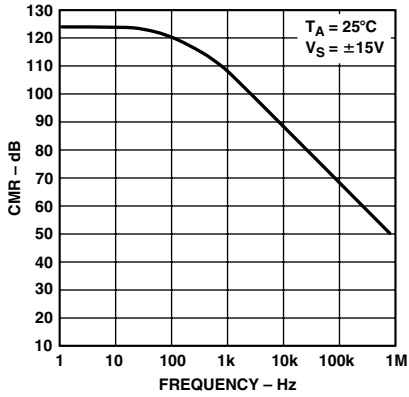

TPC 10. CMR vs. Frequency

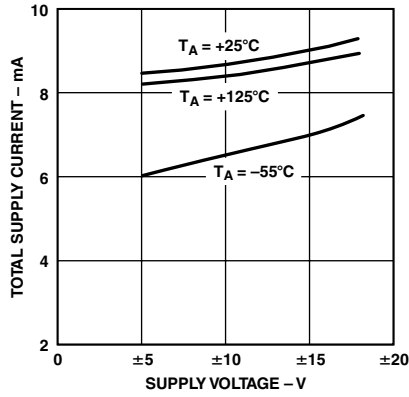

TPC 11. Total Supply Current vs. Supply Voltage

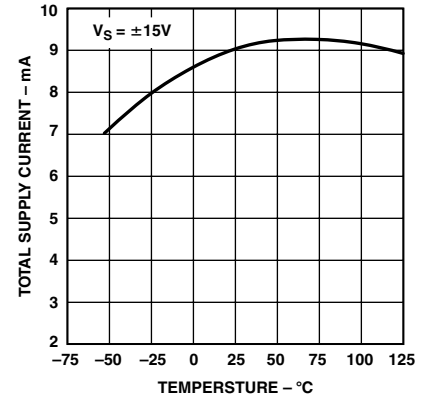

TPC 12. Total Supply Current vs. Supply Voltage

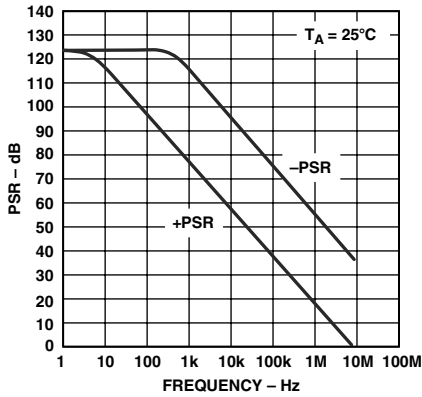

TPC 13. PSR vs. Frequency

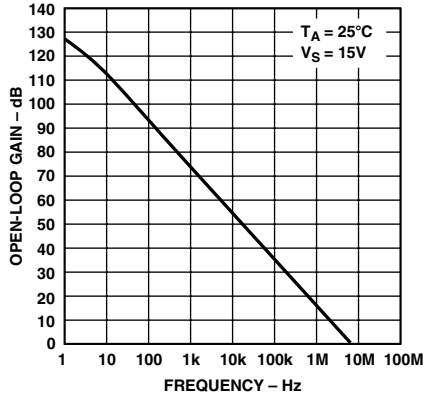

TPC 14. Open-Loop Gain vs. Frequency

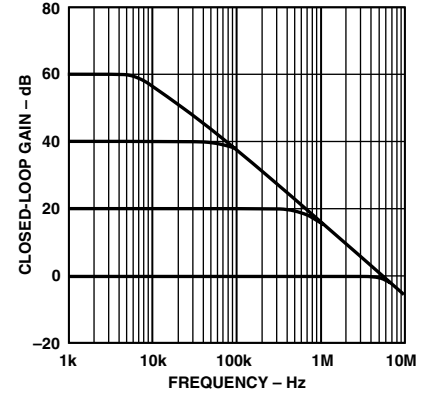

TPC 15. Closed-Loop Gain vs. Frequency

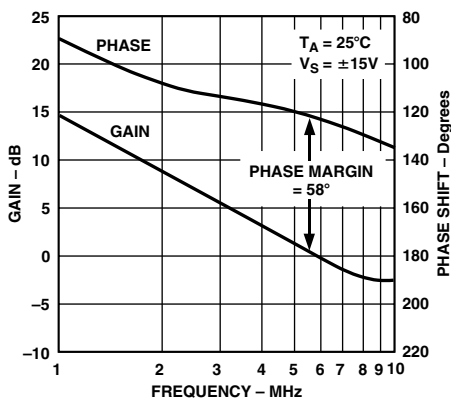

TPC 16. Open-Loop Gain, Phase Shift vs. Frequency

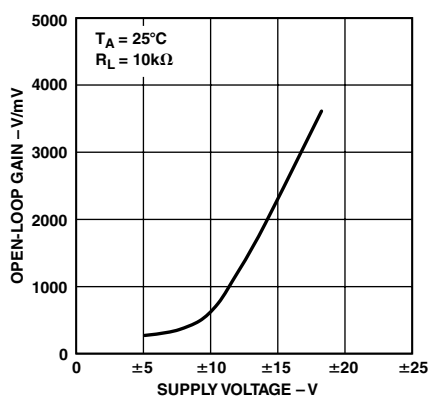

TPC 17. Open-Loop Gain vs. Supply Voltage

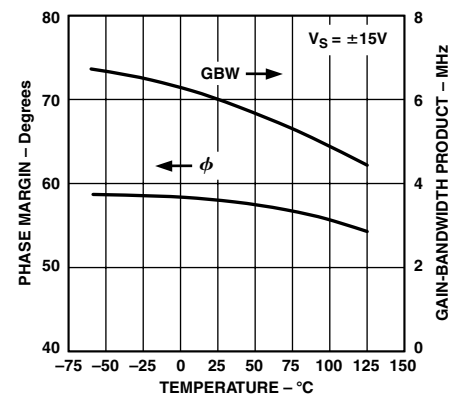

TPC 18. Gain-Bandwidth Product, Phase Margin vs. Temperature

# OP470

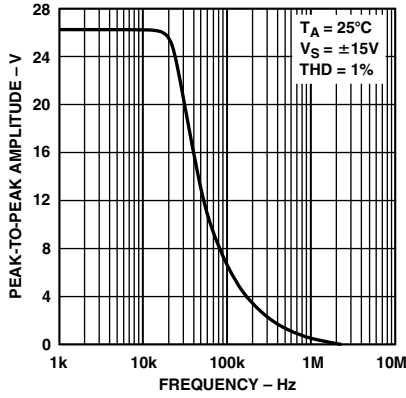

TPC 19. Maximum Output Swing vs. Frequency

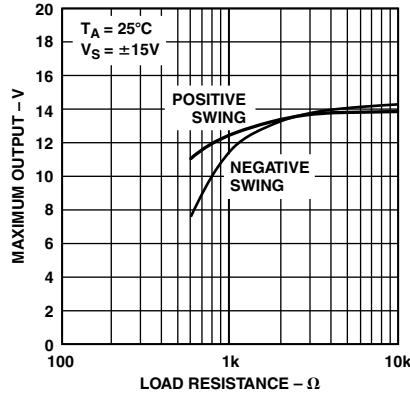

TPC 20. Maximum Output Voltage vs. Load Resistance

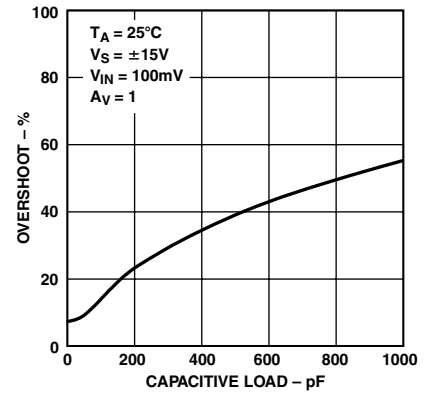

TPC 21. Small-Signal Overshoot vs. Capacitive Load

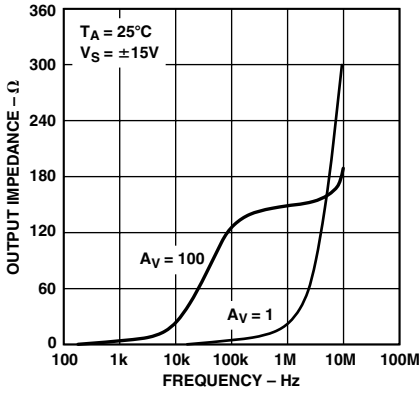

TPC 22. Output Impedance vs. Frequency

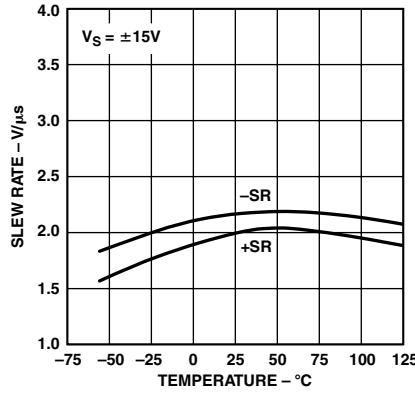

TPC 23. Slew Rate vs. Temperature

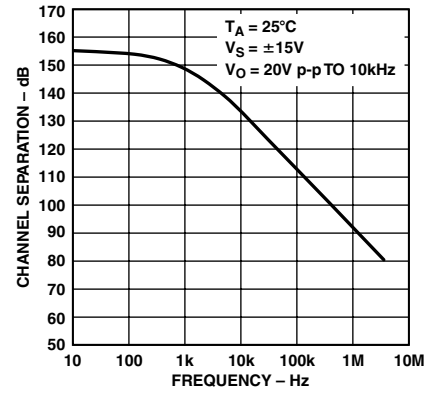

TPC 24. Channel Separation vs. Frequency

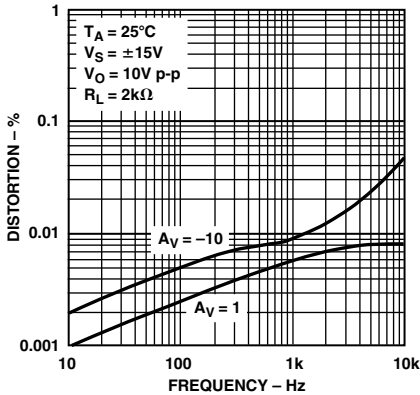

TPC 25. Total Harmonic Distortion vs. Frequency

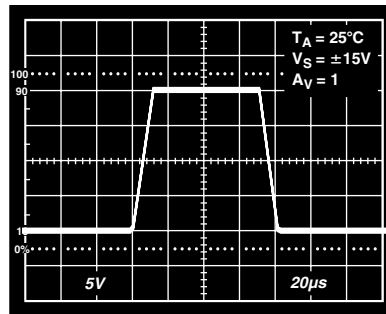

TPC 26. Large-Signal Transient Response

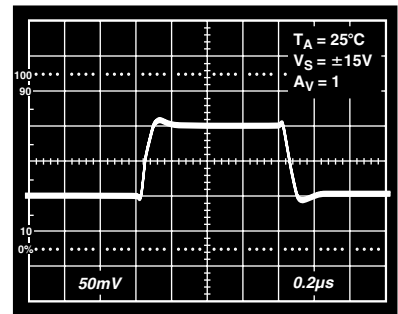

TPC 27. Small-Signal Transient Response

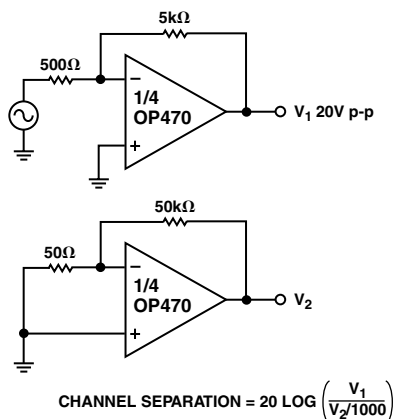

Figure 2. Channel Separation Test Circuit

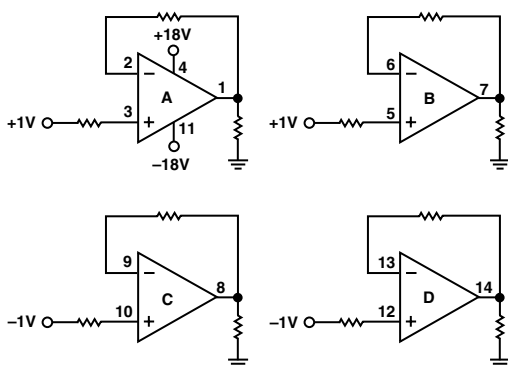

Figure 3. Burn-In Circuit

## APPLICATIONS INFORMATION

### Voltage and Current Noise

The OP470 is a very low-noise quad op amp, exhibiting a typical voltage noise of only 3.2 nV/√Hz @ 1 kHz. The exceptionally low-noise characteristics of the OP470 are in part achieved by operating the input transistors at high collector currents since the voltage noise is inversely proportional to the square root of the collector current. Current noise, however, is directly proportional to the square root of the collector current. As a result, the outstanding voltage noise performance of the OP470 is gained at the expense of current noise performance, which is typical for low noise amplifiers.

To obtain the best noise performance in a circuit, it is vital to understand the relationship between voltage noise ( $e_n$ ), current noise ( $i_n$ ), and resistor noise ( $e_r$ ).

### TOTAL NOISE AND SOURCE RESISTANCE

The total noise of an op amp can be calculated by:

$$E_n = \sqrt{(E_n)^2 + (i_n R_S)^2 + (E_r)^2}$$

where:

- $E_n$  = total input referred noise
- $e_n$  = up amp voltage noise
- $i_n$  = op amp current noise
- $e_r$  = source resistance thermal noise
- $R_S$  = source resistance

The total noise is referred to the input and at the output would be amplified by the circuit gain. Figure 4 shows the relationship between total noise at 1 kHz and source resistance. For  $R_S < 1 \text{ k}\Omega$  the total noise is dominated by the voltage noise of the OP470. As  $R_S$  rises above 1 kΩ, total noise increases and is dominated by resistor noise rather than by voltage or current noise of the OP470. When  $R_S$  exceeds 20 kΩ, current noise of the OP470 becomes the major contributor to total noise.

Figure 5 also shows the relationship between total noise and source resistance, but at 10 Hz. Total noise increases more quickly than shown in Figure 4 because current noise is inversely proportional to the square root of frequency. In Figure 5, current noise of the OP470 dominates the total noise when  $R_S > 5 \text{ k}\Omega$ .

From Figures 4 and 5 it can be seen that to reduce total noise, source resistance must be kept to a minimum. In applications with a high source resistance, the OP400, with lower current noise than the OP470, will provide lower total noise.

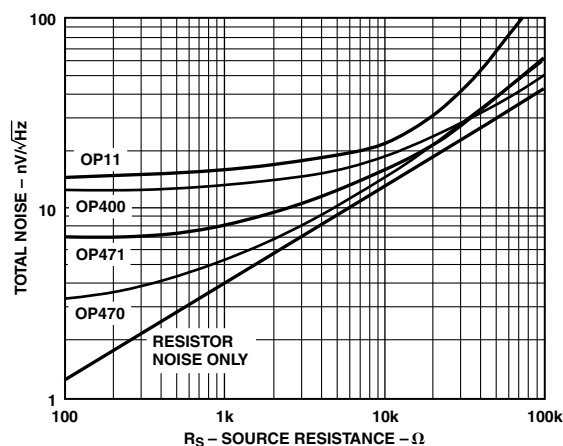

Figure 4. Total Noise vs. Source Resistance (Including Resistor Noise) at 1 kHz

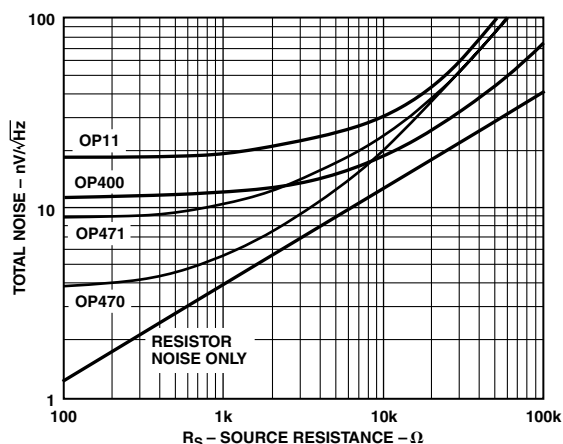

Figure 5. Total Noise vs. Source Resistance (Including Resistor Noise) at 10 Hz

# OP470

Figure 6 shows peak-to-peak noise versus source resistance over the 0.1 Hz to 10 Hz range. Once again, at low values of  $R_S$ , the voltage noise of the OP470 is the major contributor to peak-to-peak noise with current noise the major contributor as  $R_S$  increases. The crossover point between the OP470 and the OP400 for peak-to-peak noise is at  $R_S = 17 \text{ k}\Omega$ .

The OP471 is a higher speed version of the OP470, with a slew rate of  $8 \text{ V}/\mu\text{s}$ . Noise of the OP471 is only slightly higher than the OP470. Like the OP470, the OP471 is unity-gain stable.

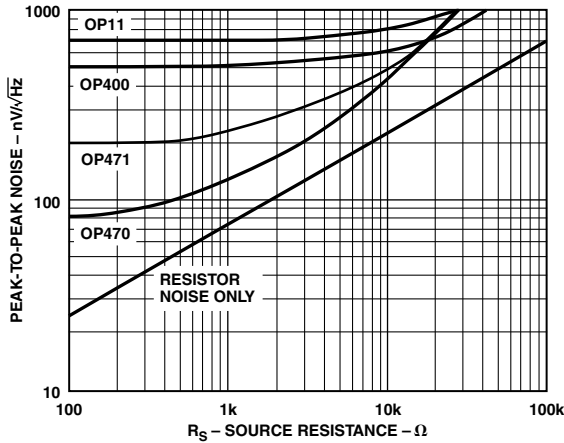

Figure 6. Peak-To-Peak Noise (0.1 Hz to 10 Hz) vs. Source Resistance (Includes Resistor Noise)

For reference, typical source resistances of some signal sources are listed in Table I.

Table I.

Source	Device Impedance	Comments
Strain gage	$<500 \Omega$	Typically used in low frequency applications.
Magnetic tapehead	$<1500 \Omega$	Low $I_B$ very important to reduce self-magnetization problems when direct coupling is used. OP470 $I_B$ can be neglected.
Magnetic phonograph cartridges	$<1500 \Omega$	Similar need for low $I_B$ in direct coupled applications. OP470 will not introduce any self-magnetization problem.
Linear variable differential transformer	$<1500 \Omega$	Used in rugged servo-feedback applications. Bandwidth of interest is 400 Hz to 5 kHz.

For further information regarding noise calculations, see “Minimization of Noise in Op Amp Applications,” Application Note AN-15.

## NOISE MEASUREMENTS— PEAK-TO-PEAK VOLTAGE NOISE

The circuit of Figure 7 is a test setup for measuring peak-to-peak voltage noise. To measure the  $200 \text{ nV}$  peak-to-peak noise specification of the OP470 in the 0.1 Hz to 10 Hz range, the following precautions must be observed:

1. The device must be warmed up for at least five minutes. As shown in the warm-up drift curve, the offset voltage typically changes  $5 \mu\text{V}$  due to increasing chip temperature after power-up. In the 10-second measurement interval, these temperature-induced effects can exceed tens of nanovolts.
2. For similar reasons, the device must be well-shielded from air currents. Shielding also minimizes thermocouple effects.
3. Sudden motion in the vicinity of the device can also “feedthrough” to increase the observed noise.

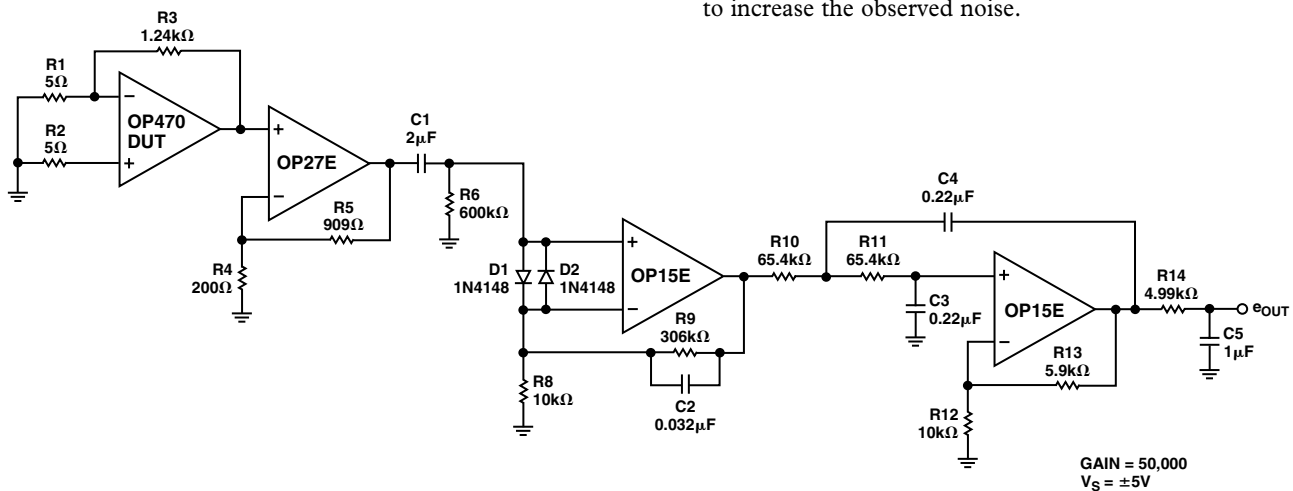

Figure 7. Peak-To-Peak Voltage Noise Test Circuit (0.1 Hz to 10 Hz)

4. The test time to measure 0.1 Hz to 10 Hz noise should not exceed 10 seconds. As shown in the noise-tester frequency-response curve of Figure 8, the 0.1 Hz corner is defined by only one pole. The test time of 10 seconds acts as an additional pole to eliminate noise contribution from the frequency band below 0.1 Hz.
5. A noise-voltage-density test is recommended when measuring noise on a large number of units. A 10 Hz noise voltage-density measurement will correlate well with a 0.1 Hz to 10 Hz peak-to-peak noise reading, since both results are determined by the white noise and the location of the 1/f corner frequency.
6. Power should be supplied to the test circuit by well bypassed low noise supplies, e.g. batteries. These will minimize output noise introduced via the amplifier supply pins.

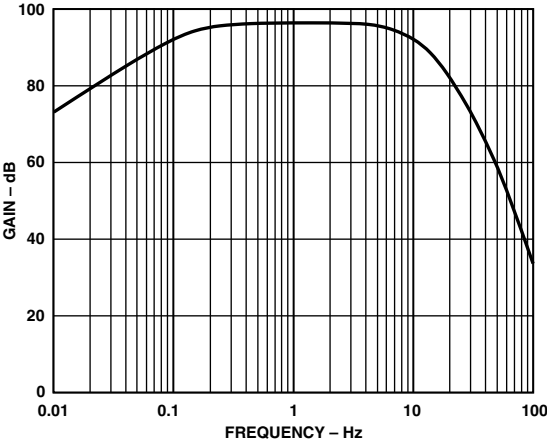

Figure 8. 0.1 Hz to 10 Hz Peak-to-Peak Voltage Noise Test Circuit Frequency Response

**NOISE MEASUREMENT—NOISE VOLTAGE DENSITY**

The circuit of Figure 9 shows a quick and reliable method of measuring the noise voltage density of quad op amps. Each individual amplifier is series-connected and is in unity-gain, save the final amplifier which is in a noninverting gain of 101. Since the ac noise voltages of each amplifier are uncorrelated, they add in rms fashion to yield:

$$e_{OUT} = 101 \left( \sqrt{e_{nA}^2 + e_{nB}^2 + e_{nC}^2 + e_{nD}^2} \right)$$

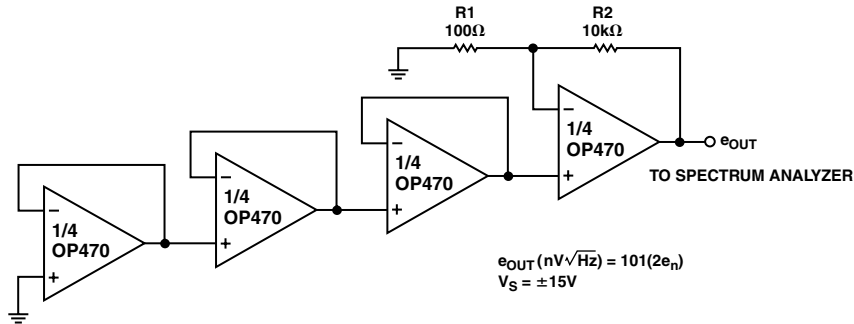

Figure 9. Noise Voltage Density Test Circuit

The OP470 is a monolithic device with four identical amplifiers. The noise voltage density of each individual amplifier will match, giving:

$$e_{OUT} = 101 \left( \sqrt{4e_n^2} \right) = 101 (2e_n)$$

**NOISE MEASUREMENT—CURRENT NOISE DENSITY**

The test circuit shown in Figure 10 can be used to measure current noise density. The formula relating the voltage output to current noise density is:

$$i_n = \frac{\sqrt{\left( \frac{\theta_{nOUT}}{G} \right)^2 - (40nV / \sqrt{Hz})^2}}{R_S}$$

where:

- G = gain of 10000
- RS = 100 kΩ source resistance

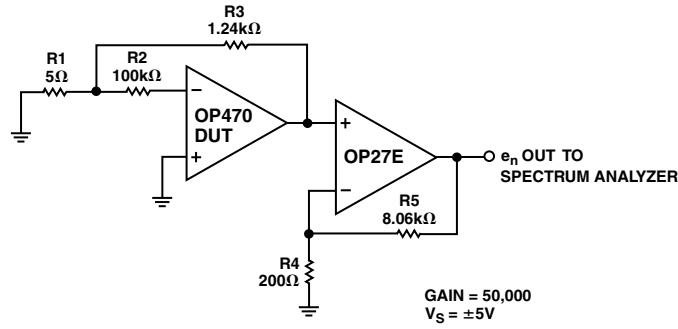

Figure 10. Current Noise Density Test Circuit

# OP470

## CAPACITIVE LOAD DRIVING AND POWER SUPPLY CONSIDERATIONS

The OP470 is unity-gain stable and is capable of driving large capacitive loads without oscillating. Nonetheless, good supply bypassing is highly recommended. Proper supply bypassing reduces problems caused by supply line noise and improves the capacitive load driving capability of the OP470.

In the standard feedback amplifier, the op amp's output resistance combines with the load capacitance to form a low pass filter that adds phase shift in the feedback network and reduces stability. A simple circuit to eliminate this effect is shown in Figure 11. The added components, C1 and R3, decouple the amplifier from the load capacitance and provide additional stability. The values of C1 and R3 shown in Figure 11 are for a load capacitance of up to 1000 pF when used with the OP470.

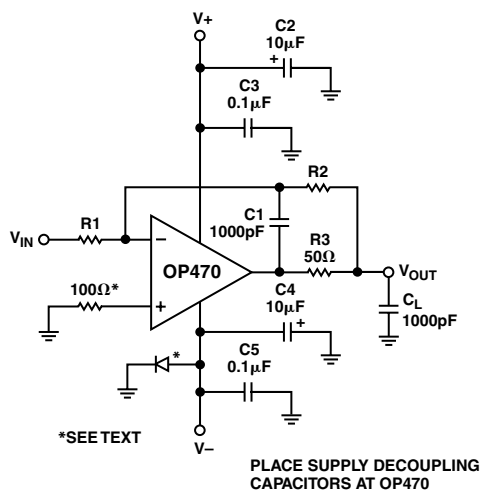

Figure 11. Driving Large Capacitive Loads

In applications where the OP470's inverting or noninverting inputs are driven by a low source impedance (under 100 Ω) or connected to ground, if V<sub>+</sub> is applied before V<sub>-</sub>, or when V is disconnected, excessive parasitic currents will flow. Most applications use dual tracking supplies and with the device supply pins properly bypassed, power-up will not present a problem. A source resistance of at least 100 Ω in series with all inputs (Figure 11) will limit the parasitic currents to a safe level if V<sub>-</sub> is disconnected. It should be noted that any source resistance, even 100 Ω, adds noise to the circuit. Where noise is required to be kept at a minimum, a germanium or Schottky diode can be used to clamp the V<sub>-</sub> pin and eliminate the parasitic current flow instead of using series limiting resistors. For most applications, only one diode clamp is required per board or system.

## UNITY-GAIN BUFFER APPLICATIONS

When R<sub>f</sub> ≤ 100 Ω and the input is driven with a fast, large signal pulse (> 1 V), the output waveform will look as shown in Figure 12.

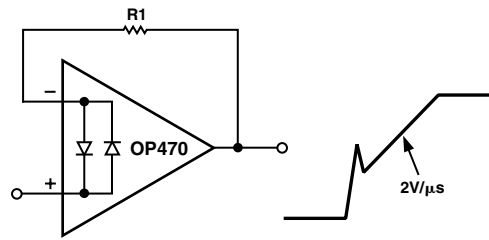

Figure 12. Pulsed Operation

During the fast feedthrough-like portion of the output, the input protection diodes effectively short the output to the input, and a current, limited only by the output short-circuit protection, will be drawn by the signal generator. With R<sub>f</sub> ≤ 500 Ω, the output is capable of handling the current requirements (I<sub>L</sub> < 20 mA at 10 V); the amplifier will stay in its active mode and a smooth transition will occur.

When R<sub>f</sub> > 3 kΩ, a pole created by R<sub>f</sub> and the amplifier's input capacitance (2 pF) creates additional phase shift and reduces phase margin. A small capacitor (20 pF to 50 pF) in parallel with R<sub>f</sub> helps eliminate this problem.

## APPLICATIONS

### Low Noise Amplifier

A simple method of reducing amplifier noise by paralleling amplifiers is shown in Figure 13. Amplifier noise, depicted in Figure 14, is around 2 nV/√Hz @ 1 kHz (R.T.I.). Gain for each paralleled amplifier and the entire circuit is 1000. The 200 Ω resistors limit circulating currents and provide an effective output resistance of 50 Ω. The amplifier is stable with a 10 nF capacitive load and can supply up to 30 mA of output drive.

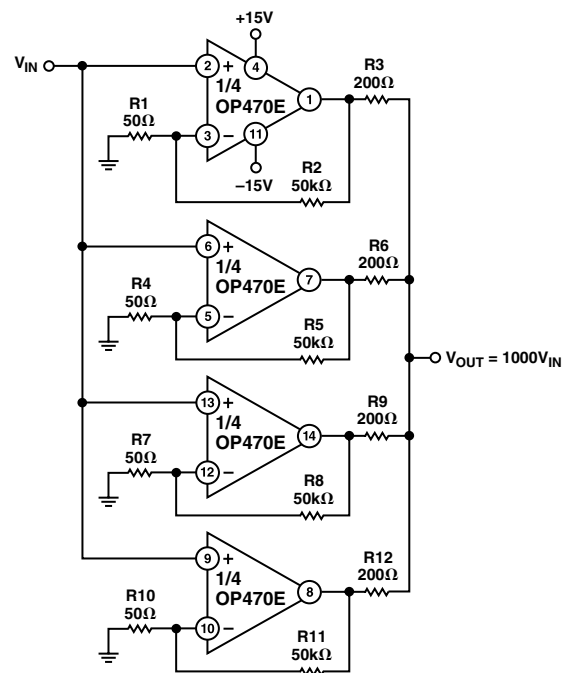

Figure 13. Low Noise Amplifier

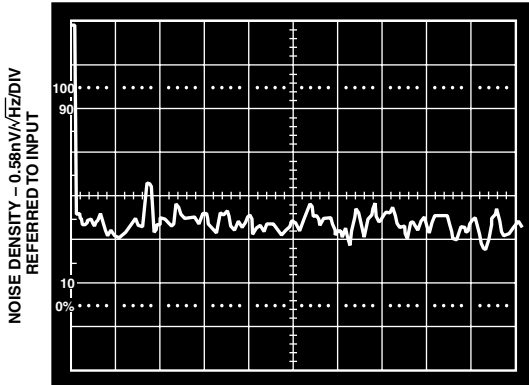

Figure 14. Noise Density of Low Noise Amplifier,  $G = 1000$

**DIGITAL PANNING CONTROL**

Figure 15 uses a DAC-8408, quad 8-bit DAC to pan a signal between two channels. The complementary DAC current outputs two of the DAC-8408's four DACs drive current-to-voltage converters built from a single quad OP470. The amplifiers have complementary outputs with the amplitudes dependent upon the digital code applied to the DAC. Figure 16 shows the complementary outputs for a 1 kHz input signal and digital ramp applied to the DAC data inputs. Distortion of the digital panning control is less than 0.01%.

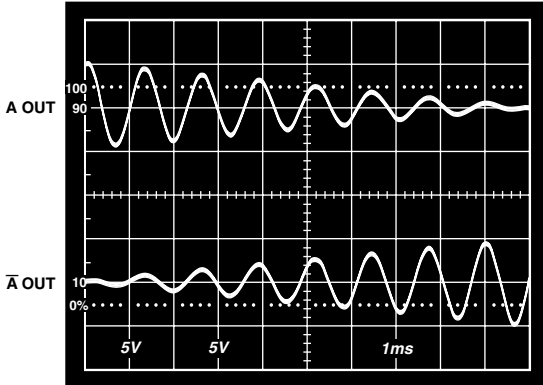

Figure 16. Digital Panning Control Output

Gain error due to the mismatching between the internal DAC ladder resistors and the current-to-voltage feedback resistors is eliminated by using feedback resistors internal to the DAC. Of the four DACs available in the DAC-8408, only two DACs, A and C, actually pass a signal. DACs B and D are used to provide the additional feedback resistors needed in the circuit. If the VREFB and VREFD inputs remain unconnected, the current-to-voltage converters using RFB B and RFB D are unaffected by digital data reaching DACs B and D.

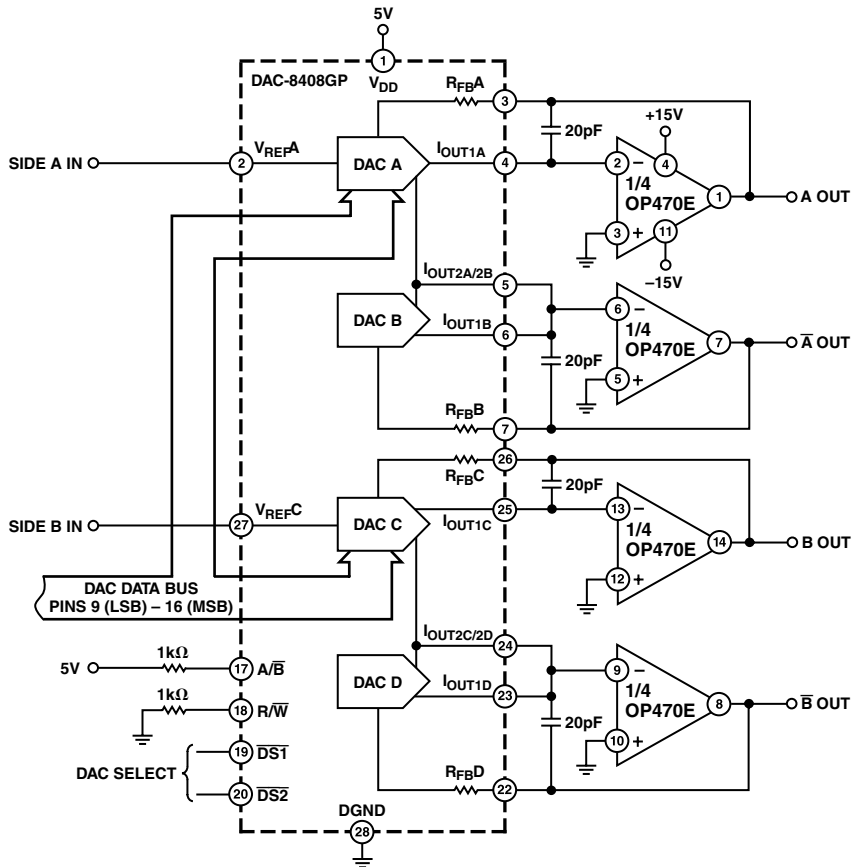

Figure 15. Digital Panning Control Circuit





# ADV611/ADV612

## Revision History

<b>Location</b>	<b>Page</b>
<b>10/02—Data Sheet changed from REV. A to REV. B.</b>	
Edits to 16-Lead SOIC .....	1
Edits to ELECTRICAL CHARACTERISTICS .....	3
Edits to ABSOLUTE MAXIMUM RATINGS .....	5
Updated OUTLINE DIMENSIONS .....	15
<b>4/02—Data Sheet changed from REV. 0 to REV. A.</b>	
28-Lead LCC (RC-Suffix) deleted .....	1
28-Lead LCC (TC-Suffix) deleted .....	1
Edits to ABSOLUTE MAXIMUM RATINGS .....	4
Edits to ORDERING GUIDE .....	4
Edits to PACKAGE TYPE .....	4

C00305-0-10/02(B)

PRINTED IN U.S.A.