



OPA121

## Low Cost Precision *Difet*<sup>®</sup> OPERATIONAL AMPLIFIER

### FEATURES

- LOW NOISE:  $6\text{nV}/\sqrt{\text{Hz}}$  typ at 10kHz
- LOW BIAS CURRENT: 5pA max
- LOW OFFSET: 2mV max
- LOW DRIFT:  $3\mu\text{V}/^\circ\text{C}$  typ
- HIGH OPEN-LOOP GAIN: 110dB min
- HIGH COMMON-MODE REJECTION: 86dB min

### APPLICATIONS

- OPTOELECTRONICS
- DATA ACQUISITION
- TEST EQUIPMENT
- MEDICAL EQUIPMENT
- RADIATION HARD EQUIPMENT

### DESCRIPTION

The OPA121 is a precision monolithic dielectrically-isolated FET (*Difet*<sup>®</sup>) operational amplifier. Outstanding performance characteristics are now available for low-cost applications.

Noise, bias current, voltage offset, drift, open-loop gain, common-mode rejection, and power supply rejection are superior to BIFET<sup>®</sup> amplifiers.

Very low bias current is obtained by dielectric isolation with on-chip guarding.

Laser-trimming of thin-film resistors gives very low offset and drift. Extremely low noise is achieved with new circuit design techniques (patented). A new cascode design allows high precision input specifications and reduced susceptibility to flicker noise.

Standard 741 pin configuration allows upgrading of existing designs to higher performance levels.

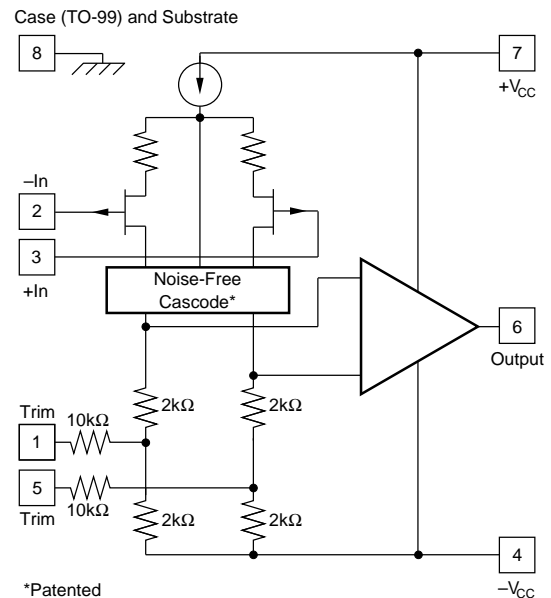

OPA121 Simplified Circuit

*Difet*<sup>®</sup>, Burr-Brown Corp.  
BIFET<sup>®</sup>, National Semiconductor Corp.

International Airport Industrial Park • Mailing Address: PO Box 11400 • Tucson, AZ 85734 • Street Address: 6730 S. Tucson Blvd. • Tucson, AZ 85706  
Tel: (520) 746-1111 • Twx: 910-952-1111 • Cable: BBRCORP • Telex: 066-6491 • FAX: (520) 889-1510 • Immediate Product Info: (800) 548-6132

# SPECIFICATIONS

## ELECTRICAL

At  $V_{CC} = \pm 15\text{VDC}$  and  $T_A = +25^\circ\text{C}$  unless otherwise noted. Pin 8 connected to ground.

PARAMETER	CONDITIONS	OPA121KM			OPA121KP, KU			UNITS
		MIN	TYP	MAX	MIN	TYP	MAX	
<b>INPUT NOISE</b> Voltage, $f_o = 10\text{Hz}$ $f_o = 100\text{Hz}$ $f_o = 1\text{kHz}$ $f_o = 10\text{kHz}$ $f_B = 10\text{Hz}$ to $10\text{kHz}$ $f_B = 0.1\text{Hz}$ to $10\text{Hz}$ Current, $f_B = 0.1\text{Hz}$ to $10\text{Hz}$ $f_o = 0.1\text{Hz}$ thru $20\text{kHz}$	(1) (1) (1) (1) (1) (1) (1)		40 15 8 6 0.7 1.6 15 0.8			50 18 10 7 0.8 2 21 1.1		$\text{nV}/\sqrt{\text{Hz}}$ $\text{nV}/\sqrt{\text{Hz}}$ $\text{nV}/\sqrt{\text{Hz}}$ $\text{nV}/\sqrt{\text{Hz}}$ $\mu\text{Vrms}$ $\mu\text{Vp-p}$ $\text{fA, p-p}$ $\text{fA}/\sqrt{\text{Hz}}$
<b>OFFSET VOLTAGE<sup>(2)</sup></b> Input Offset Voltage Average Drift Supply Rejection	$V_{CM} = 0\text{VDC}$ $T_A = T_{MIN}$ to $T_{MAX}$		$\pm 0.5$ $\pm 3$ $\pm 6$	$\pm 2$ $\pm 10$ $\pm 50$		$\pm 0.5$ $\pm 3$ $\pm 6$	$\pm 3$ $\pm 10$ $\pm 50$	mV $\mu\text{V}/^\circ\text{C}$ dB $\mu\text{V/V}$
<b>BIAS CURRENT<sup>(2)</sup></b> Input Bias Current	$V_{CM} = 0\text{VDC}$ Device Operating		$\pm 1$	$\pm 5$		$\pm 1$	$\pm 10$	pA
<b>OFFSET CURRENT<sup>(2)</sup></b> Input Offset Current	$V_{CM} = 0\text{VDC}$ Device Operating		$\pm 0.7$	$\pm 4$		$\pm 0.7$	$\pm 8$	pA
<b>IMPEDANCE</b> Differential Common-Mode			$10^{13} \parallel 1$ $10^{14} \parallel 3$			$10^{13} \parallel 1$ $10^{14} \parallel 3$		$\Omega \parallel \text{pF}$ $\Omega \parallel \text{pF}$
<b>VOLTAGE RANGE</b> Common-Mode Input Range Common-Mode Rejection	$V_{IN} = \pm 10\text{VDC}$	$\pm 10$ 86	$\pm 11$ 104		$\pm 10$ 82	$\pm 11$ 100		V dB
<b>OPEN-LOOP GAIN, DC</b> Open-Loop Voltage Gain	$R_L \geq 2\text{k}\Omega$	110	120		106	114		dB
<b>FREQUENCY RESPONSE</b> Unity Gain, Small Signal Full Power Response Slew Rate Settling Time, 0.1% 0.01% Overload Recovery, 50% Overdrive <sup>(3)</sup>	20Vp-p, $R_L = 2\text{k}\Omega$ $V_O = \pm 10\text{V}$ , $R_L = 2\text{k}\Omega$ Gain = -1, $R_L = 2\text{k}\Omega$ 10V Step Gain = -1		2 32 2 6 10 5			2 32 2 6 10 5		MHz kHz V/ $\mu\text{s}$ $\mu\text{s}$ $\mu\text{s}$ $\mu\text{s}$
<b>RATED OUTPUT</b> Voltage Output Current Output Output Resistance Load Capacitance Stability Short Circuit Current	$R_L = 2\text{k}\Omega$ $V_O = \pm 10\text{VDC}$ DC, Open Loop Gain = +1	$\pm 11$ $\pm 5.5$	$\pm 12$ $\pm 10$ 100 1000 40		$\pm 11$ $\pm 5.5$	$\pm 12$ $\pm 10$ 100 1000 40		V mA $\Omega$ pF mA
<b>POWER SUPPLY</b> Rated Voltage Voltage Range, Derated Performance Current, Quiescent	$I_O = 0\text{mADC}$	$\pm 5$	$\pm 15$ 2.5	$\pm 18$ 4	$\pm 5$	$\pm 15$ 2.5	$\pm 18$ 4.5	VDC VDC mA
<b>TEMPERATURE RANGE</b> Specification Operating Storage $\theta$ Junction-Ambient	Ambient Temperature Ambient Temperature Ambient Temperature	0 -40 -65		+70 +85 +150	0 -25 -55		+70 +85 +125	$^\circ\text{C}$ $^\circ\text{C}$ $^\circ\text{C}$ $^\circ\text{C/W}$

NOTES: (1) Sample tested. (2) Offset voltage, offset current, and bias current are specified with the units fully warmed up. (3) Overload recovery is defined as the time required for the output to return from saturation to linear operation following the removal of a 50% input overdrive. (4)  $100^\circ\text{C/W}$  for KU grade.

The information provided herein is believed to be reliable; however, BURR-BROWN assumes no responsibility for inaccuracies or omissions. BURR-BROWN assumes no responsibility for the use of this information, and all use of such information shall be entirely at the user's own risk. Prices and specifications are subject to change without notice. No patent rights or licenses to any of the circuits described herein are implied or granted to any third party. BURR-BROWN does not authorize or warrant any BURR-BROWN product for use in life support devices and/or systems.

## ELECTRICAL (FULL TEMPERATURE RANGE SPECIFICATIONS)

At  $V_{CC} = \pm 15\text{VDC}$  and  $T_A = T_{MIN}$  to  $T_{MAX}$  unless otherwise noted.

PARAMETER	CONDITIONS	OPA121KM			OPA121KP, KU			UNITS
		MIN	TYP	MAX	MIN	TYP	MAX	
<b>TEMPERATURE RANGE</b> Specification Range	Ambient Temperature	0		+70	0		+70	°C
<b>INPUT OFFSET VOLTAGE<sup>(1)</sup></b> Input Offset Voltage Average Drift Supply Rejection	$V_{CM} = 0\text{VDC}$		$\pm 1$ $\pm 3$ 94	$\pm 3$ $\pm 10$ $\pm 80$		$\pm 1$ $\pm 3$ 94 $\pm 20$	$\pm 5$ $\pm 10$ $\pm 80$	mV $\mu\text{V}/^\circ\text{C}$ dB $\mu\text{V}/\text{V}$
<b>BIAS CURRENT<sup>(1)</sup></b> Input Bias Current	$V_{CM} = 0\text{VDC}$ Device Operating		$\pm 23$	$\pm 115$		$\pm 23$	$\pm 250$	pA
<b>OFFSET CURRENT<sup>(1)</sup></b> Input Offset Current	$V_{CM} = 0\text{VDC}$ Device Operating		$\pm 16$	$\pm 100$		$\pm 16$	$\pm 200$	pA
<b>VOLTAGE RANGE</b> Common-Mode Input Range Common-Mode Rejection	$V_{IN} = \pm 10\text{VDC}$	$\pm 10$ 82	$\pm 11$ 98		$\pm 10$ 80	$\pm 11$ 96		V dB
<b>OPEN-LOOP GAIN, DC</b> Open-Loop Voltage Gain	$R_L \geq 2\text{k}\Omega$	106	116		100	110		dB
<b>RATED OUTPUT</b> Voltage Output Current Output Short Circuit Current	$R_L = 2\text{k}\Omega$ $V_O = \pm 10\text{VDC}$ $V_O = 0\text{VDC}$	$\pm 10.5$ $\pm 5.25$ 10	$\pm 11$ $\pm 10$ 40		$\pm 10.5$ $\pm 5.25$ 10	$\pm 11$ $\pm 10$ 40		V mA mA
<b>POWER SUPPLY</b> Current, Quiescent	$I_O = 0\text{mADC}$		2.5	4.5		2.5	5	mA

NOTE: (1) Offset voltage, offset current, and bias current are measured with the units fully warmed up.

## ABSOLUTE MAXIMUM RATINGS

Supply .....	$\pm 18\text{VDC}$
Internal Power Dissipation <sup>(1)</sup> .....	500mW
Differential Input Voltage .....	$\pm 36\text{VDC}$
Input Voltage Range .....	$\pm 18\text{VDC}$
Storage Temperature Range	
M package .....	$-65^\circ\text{C}$ to $+150^\circ\text{C}$
P, U packages .....	$-55^\circ\text{C}$ to $+125^\circ\text{C}$
Operating Temperature Range	
M package .....	$-40^\circ\text{C}$ to $+85^\circ\text{C}$
P, U packages .....	$-25^\circ\text{C}$ to $+85^\circ\text{C}$
Lead Temperature	
M, P packages (soldering, 10s) .....	$+300^\circ\text{C}$
U package (soldering, 3s) .....	$+260^\circ\text{C}$
Output Short-Circuit Duration <sup>(2)</sup> .....	Continuous
Junction Temperature .....	$+175^\circ\text{C}$

NOTES: (1) Packages must be derated based on  $\theta_{JA} = 150^\circ\text{C}/\text{W}$  (P package);  $\theta_{JA} = 200^\circ\text{C}/\text{W}$  (M package);  $\theta_{JA} = 100^\circ\text{C}/\text{W}$  (U package).  
(2) Short circuit may be to power supply common only. Rating applies to  $+25^\circ\text{C}$  ambient. Observe dissipation limit and  $T_J$ .

## PACKAGE INFORMATION

MODEL	PACKAGE	PACKAGE DRAWING NUMBER <sup>(1)</sup>
OPA121KM	TO-99	001
OPA121KP	8-Pin Plastic DIP	006
OPA121KU	8-Pin SOIC	182

NOTE: (1) For detailed drawing and dimension table, please see end of data sheet, or Appendix D of Burr-Brown IC Data Book.

## ORDERING INFORMATION

MODEL	PACKAGE	TEMPERATURE RANGE
OPA121KM	TO-99	$0^\circ\text{C}$ to $+70^\circ\text{C}$
OPA121KP	8-Pin Plastic DIP	$0^\circ\text{C}$ to $+70^\circ\text{C}$
OPA121KU	8-Pin SOIC	$0^\circ\text{C}$ to $+70^\circ\text{C}$

## CONNECTION DIAGRAMS

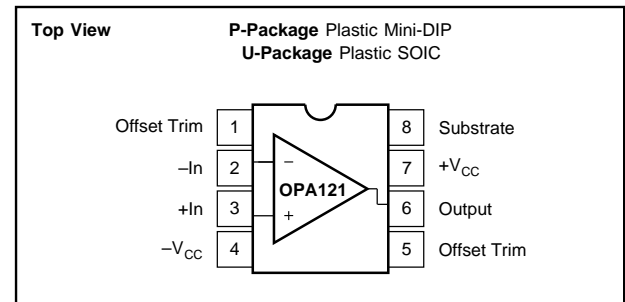
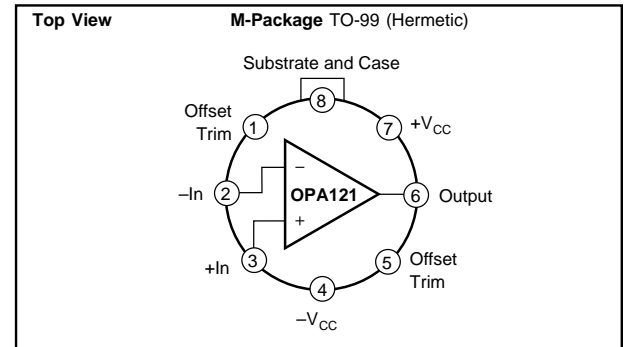

# TYPICAL PERFORMANCE CURVES

$T_A = +25^\circ\text{C}$ ,  $V_{CC} = \pm 15\text{VDC}$  unless otherwise noted.

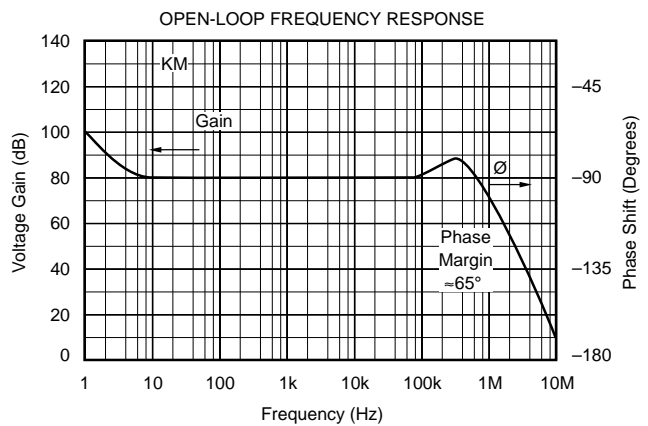
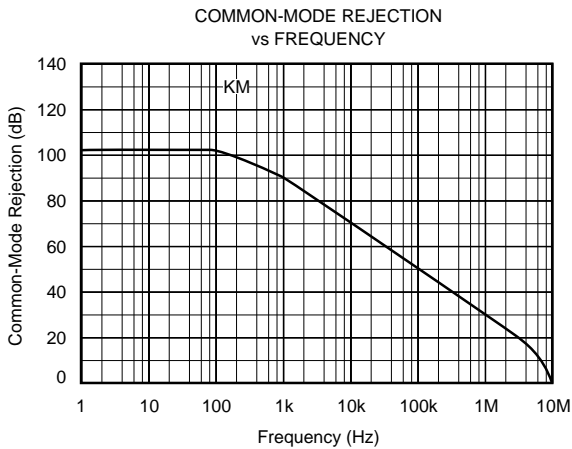
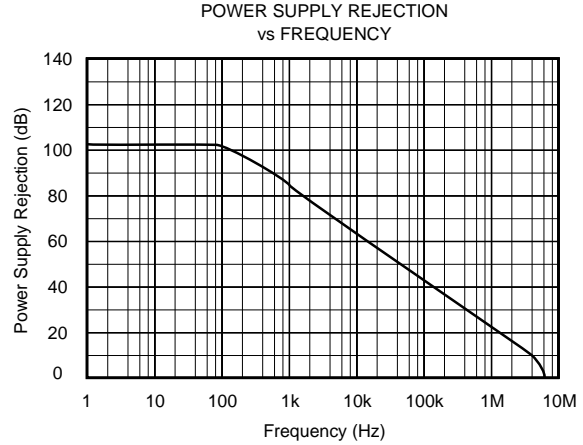
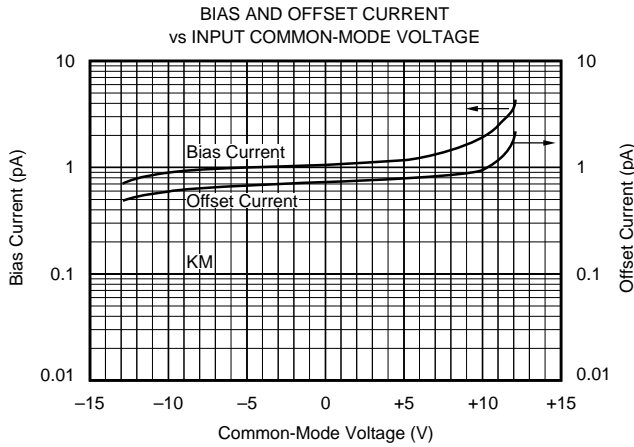
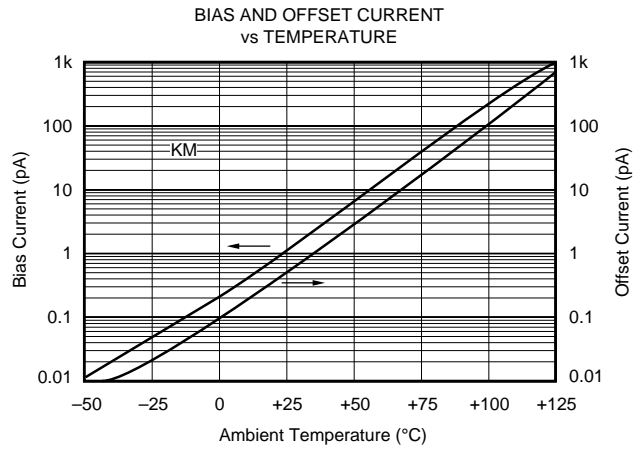
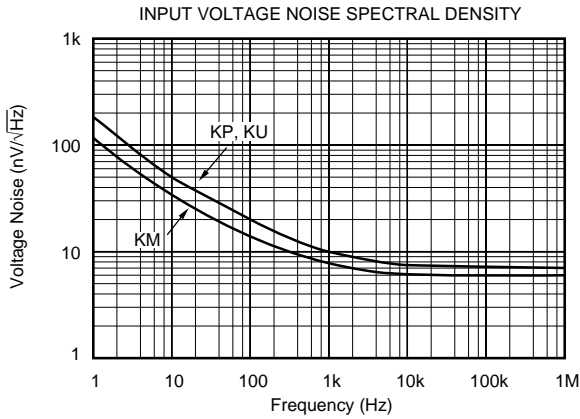

# TYPICAL PERFORMANCE CURVES (CONT)

$T_A = +25^\circ\text{C}$ ,  $V_{CC} = \pm 15\text{VDC}$  unless otherwise noted.

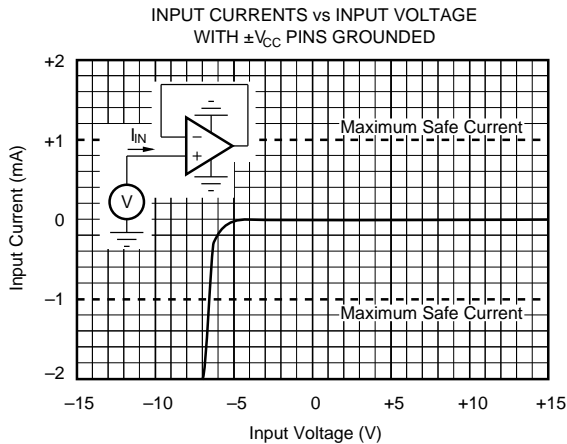
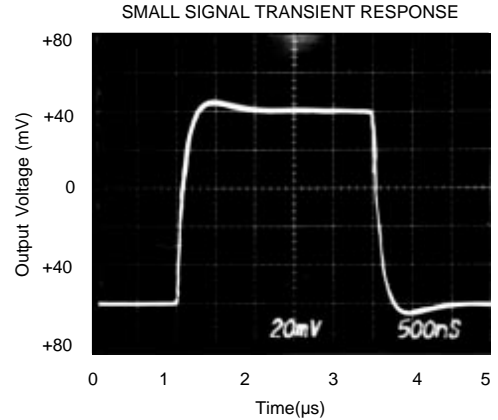
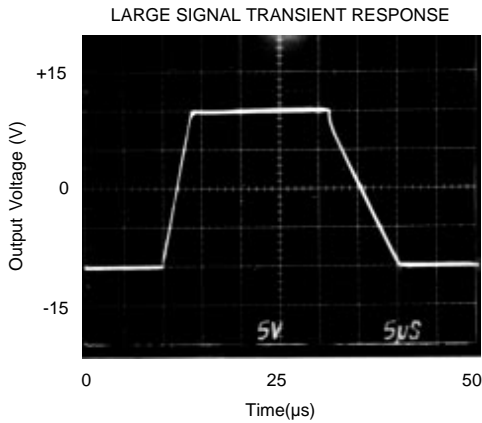

## APPLICATIONS INFORMATION

### OFFSET VOLTAGE ADJUSTMENT

The OPA121 offset voltage is laser-trimmed and will require no further trim for most applications. As with most amplifiers, externally trimming the remaining offset can change drift performance by about  $0.3\mu\text{V}/^\circ\text{C}$  for each  $100\mu\text{V}$  of adjusted offset. Note that the trim (Figure 1) is similar to operational amplifiers such as 741 and AD547. The OPA121 can replace most BIFET amplifiers by leaving the external null circuit unconnected.

### INPUT PROTECTION

Conventional monolithic FET operational amplifiers require external current-limiting resistors to protect their inputs against destructive currents that can flow when input FET gate-to-substrate isolation diodes are forward-biased. Most BIFET amplifiers can be destroyed by the loss of  $-V_{CC}$ .

Unlike BIFET amplifiers, the *Difet* OPA121 requires input current limiting resistors only if its input voltage is greater

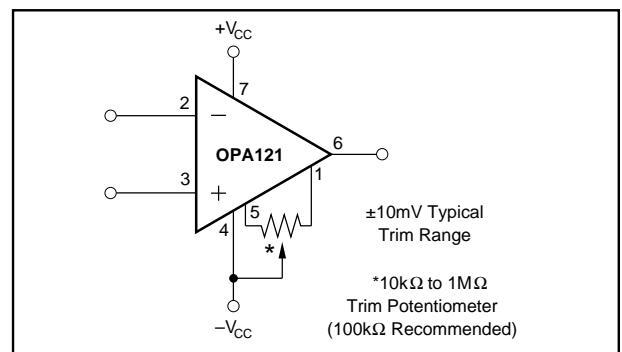

FIGURE 1. Offset Voltage Trim.

than  $6\text{V}$  more negative than  $-V_{CC}$ . A  $10\text{k}\Omega$  series resistor will limit input current to a safe level with up to  $\pm 15\text{V}$  input levels even if both supply voltages are lost.

Static damage can cause subtle changes in amplifier input characteristics without necessarily destroying the device. In precision operational amplifiers (both bipolar and FET types),

this may cause a noticeable degradation of offset voltage and drift.

Static protection is recommended when handling any precision IC operational amplifier.

### GUARDING AND SHIELDING

As in any situation where high impedances are involved, careful shielding is required to reduce “hum” pickup in input leads. If large feedback resistors are used, they should also be shielded along with the external input circuitry.

Leakage currents across printed circuit boards can easily exceed the bias current of the OPA121. To avoid leakage problems, it is recommended that the signal input lead of the OPA121 be wired to a Teflon™ standoff. If the OPA121 is to be soldered directly into a printed circuit board, utmost care must be used in planning the board layout. A “guard” pattern should completely surround the high-impedance input leads and should be connected to a low-impedance point which is at the signal input potential.

The amplifier case should be connected to any input shield or guard via pin 8. This insures that the amplifier itself is fully surrounded by guard potential, minimizing both leakage and noise pickup (see Figure #2).

If guarding is not required, pin 8 (case) should be connected to ground.

### BIAS CURRENT CHANGE VERSUS COMMON-MODE VOLTAGE

The input bias currents of most popular BIFET operational amplifiers are affected by common-mode voltage (Figure 3). Higher input FET gate-to-drain voltage causes leakage and ionization (bias) currents to increase. Due to its cascode input stage, the extremely-low bias current of the OPA121 is not compromised by common-mode voltage.

Teflon™ E.I. du Pont de Nemours & Co.

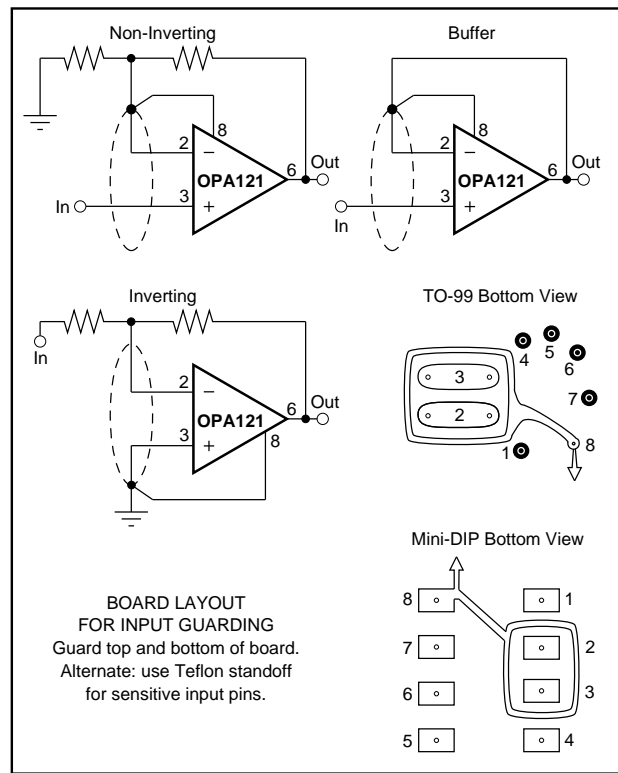

FIGURE 2. Connection of Input Guard.

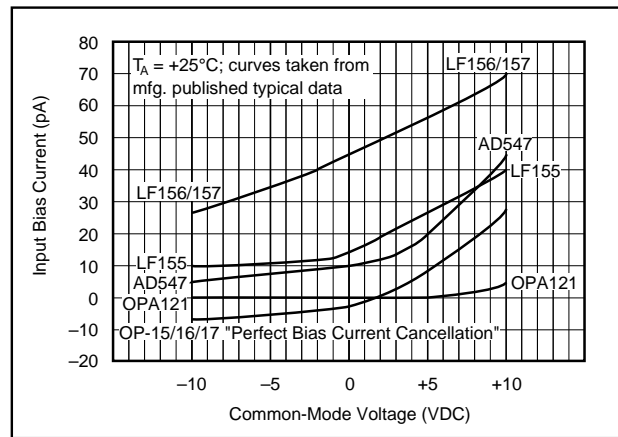

FIGURE 3. Input Bias Current vs Common-Mode Voltage.

**PACKAGING INFORMATION**

Orderable Device	Status (1)	Package Type	Package Drawing	Pins	Package Qty	Eco Plan (2)	Lead/Ball Finish (6)	MSL Peak Temp (3)	Op Temp (°C)	Device Marking (4/5)	Samples
OPA121KM	OBSOLETE	TO-99	LMC	8		TBD	Call TI	Call TI			
OPA121KM3	OBSOLETE	TO-99	LMC	8		TBD	Call TI	Call TI			
OPA121KP	OBSOLETE	PDIP	P	8		TBD	Call TI	Call TI			
OPA121KP4	OBSOLETE	PDIP	P	8		TBD	Call TI	Call TI			
OPA121KU	ACTIVE	SOIC	D	8	75	Green (RoHS & no Sb/Br)	CU NIPDAU	Level-3-260C-168 HR	0 to 70	OPA 121KU	<b>Samples</b>
OPA121KU/2K5	ACTIVE	SOIC	D	8	2500	Green (RoHS & no Sb/Br)	CU NIPDAU	Level-3-260C-168 HR	0 to 70	OPA 121KU	<b>Samples</b>
OPA121KUE4	ACTIVE	SOIC	D	8	75	Green (RoHS & no Sb/Br)	CU NIPDAU	Level-3-260C-168 HR	0 to 70	OPA 121KU	<b>Samples</b>

(1) The marketing status values are defined as follows:

**ACTIVE:** Product device recommended for new designs.

**LIFEBUY:** TI has announced that the device will be discontinued, and a lifetime-buy period is in effect.

**NRND:** Not recommended for new designs. Device is in production to support existing customers, but TI does not recommend using this part in a new design.

**PREVIEW:** Device has been announced but is not in production. Samples may or may not be available.

**OBSOLETE:** TI has discontinued the production of the device.

(2) Eco Plan - The planned eco-friendly classification: Pb-Free (RoHS), Pb-Free (RoHS Exempt), or Green (RoHS & no Sb/Br) - please check <http://www.ti.com/productcontent> for the latest availability information and additional product content details.

**TBD:** The Pb-Free/Green conversion plan has not been defined.

**Pb-Free (RoHS):** TI's terms "Lead-Free" or "Pb-Free" mean semiconductor products that are compatible with the current RoHS requirements for all 6 substances, including the requirement that lead not exceed 0.1% by weight in homogeneous materials. Where designed to be soldered at high temperatures, TI Pb-Free products are suitable for use in specified lead-free processes.

**Pb-Free (RoHS Exempt):** This component has a RoHS exemption for either 1) lead-based flip-chip solder bumps used between the die and package, or 2) lead-based die adhesive used between the die and leadframe. The component is otherwise considered Pb-Free (RoHS compatible) as defined above.

**Green (RoHS & no Sb/Br):** TI defines "Green" to mean Pb-Free (RoHS compatible), and free of Bromine (Br) and Antimony (Sb) based flame retardants (Br or Sb do not exceed 0.1% by weight in homogeneous material)

(3) MSL, Peak Temp. - The Moisture Sensitivity Level rating according to the JEDEC industry standard classifications, and peak solder temperature.

(4) There may be additional marking, which relates to the logo, the lot trace code information, or the environmental category on the device.

(5) Multiple Device Markings will be inside parentheses. Only one Device Marking contained in parentheses and separated by a "-" will appear on a device. If a line is indented then it is a continuation of the previous line and the two combined represent the entire Device Marking for that device.

<sup>(6)</sup> Lead/Ball Finish - Orderable Devices may have multiple material finish options. Finish options are separated by a vertical ruled line. Lead/Ball Finish values may wrap to two lines if the finish value exceeds the maximum column width.

**Important Information and Disclaimer:**The information provided on this page represents TI's knowledge and belief as of the date that it is provided. TI bases its knowledge and belief on information provided by third parties, and makes no representation or warranty as to the accuracy of such information. Efforts are underway to better integrate information from third parties. TI has taken and continues to take reasonable steps to provide representative and accurate information but may not have conducted destructive testing or chemical analysis on incoming materials and chemicals. TI and TI suppliers consider certain information to be proprietary, and thus CAS numbers and other limited information may not be available for release.

In no event shall TI's liability arising out of such information exceed the total purchase price of the TI part(s) at issue in this document sold by TI to Customer on an annual basis.

**TAPE AND REEL INFORMATION**
**REEL DIMENSIONS**

**TAPE DIMENSIONS**

A0	Dimension designed to accommodate the component width
B0	Dimension designed to accommodate the component length
K0	Dimension designed to accommodate the component thickness
W	Overall width of the carrier tape
P1	Pitch between successive cavity centers

**TAPE AND REEL INFORMATION**

\*All dimensions are nominal

Device	Package Type	Package Drawing	Pins	SPQ	Reel Diameter (mm)	Reel Width W1 (mm)	A0 (mm)	B0 (mm)	K0 (mm)	P1 (mm)	W (mm)	Pin1 Quadrant
OPA121KU/2K5	SOIC	D	8	2500	330.0	12.4	6.4	5.2	2.1	8.0	12.0	Q1

**TAPE AND REEL BOX DIMENSIONS**



\*All dimensions are nominal

Device	Package Type	Package Drawing	Pins	SPQ	Length (mm)	Width (mm)	Height (mm)
OPA121KU/2K5	SOIC	D	8	2500	367.0	367.0	35.0

LMC (O-MBCY-W8)

METAL CYLINDRICAL PACKAGE

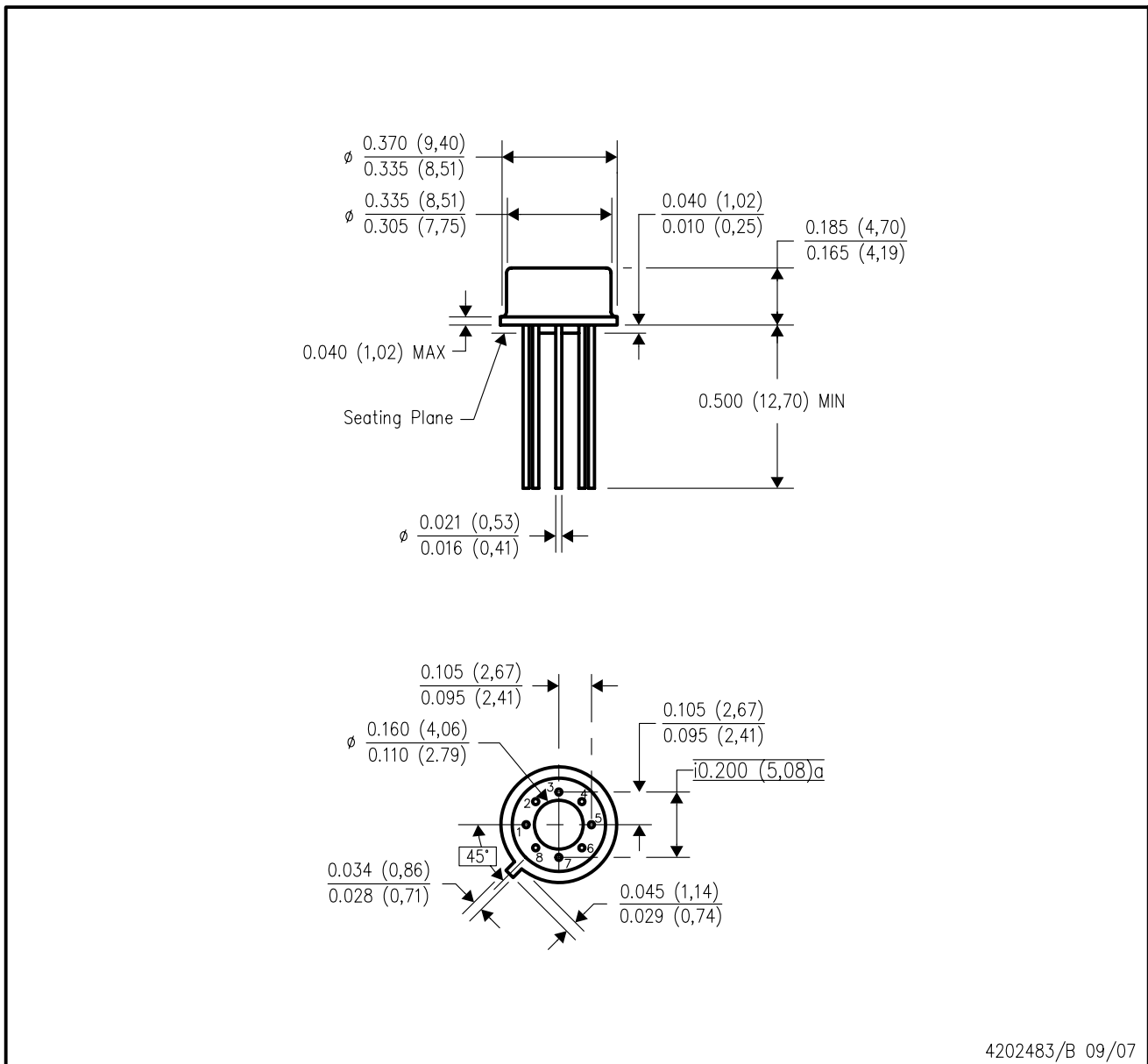

- NOTES:
- A. All linear dimensions are in inches (millimeters).
  - B. This drawing is subject to change without notice.
  - C. Leads in true position within 0.010 (0,25) R @ MMC at seating plane.
  - D. Pin numbers shown for reference only. Numbers may not be marked on package.
  - E. Falls within JEDEC MO-002/TO-99.

P (R-PDIP-T8)

PLASTIC DUAL-IN-LINE PACKAGE



- NOTES:
- A. All linear dimensions are in inches (millimeters).
  - B. This drawing is subject to change without notice.
  - C. Falls within JEDEC MS-001 variation BA.

D (R-PDSO-G8)

PLASTIC SMALL OUTLINE

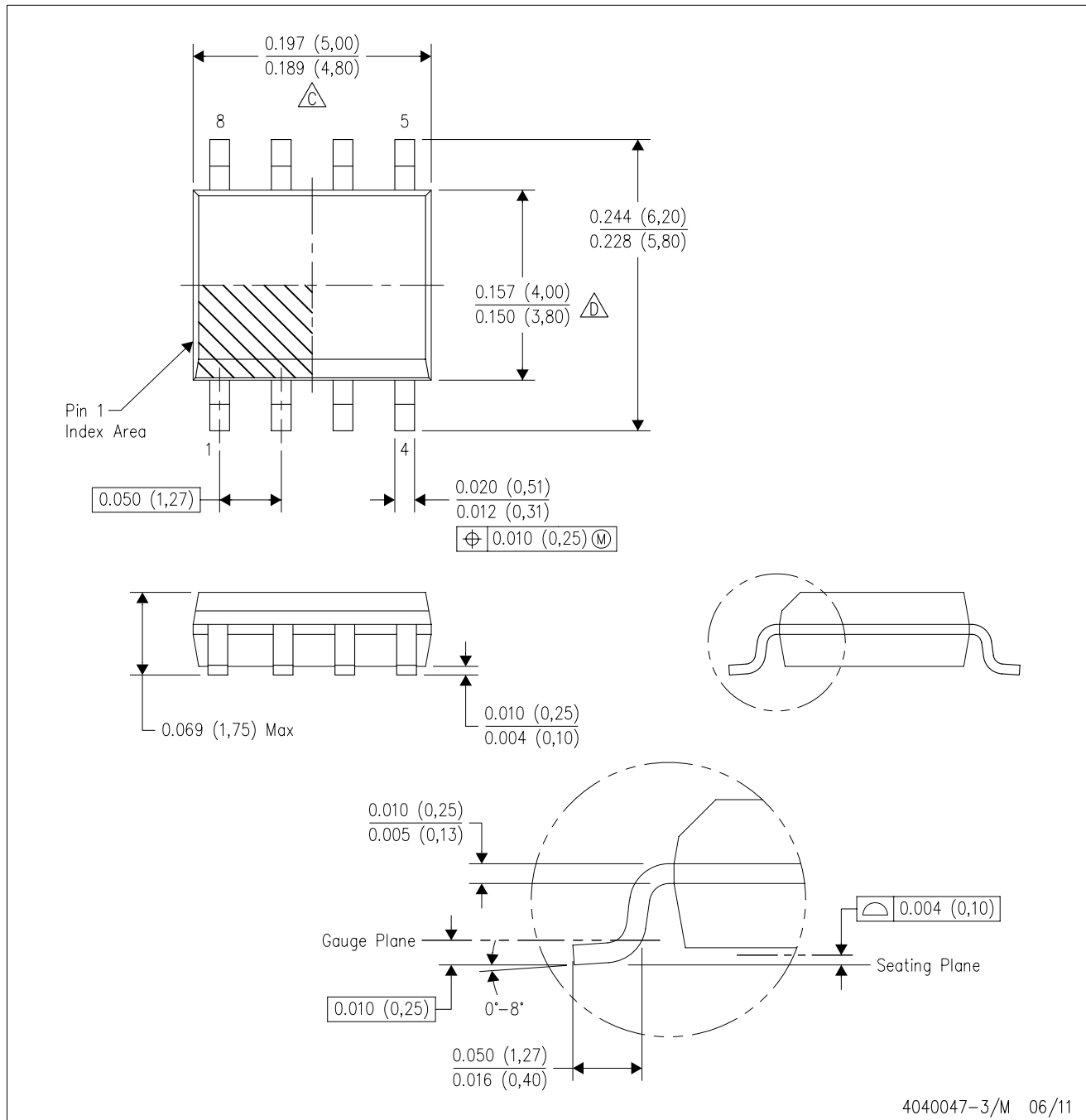

NOTES: A. All linear dimensions are in inches (millimeters).  
 B. This drawing is subject to change without notice.  
 C. Body length does not include mold flash, protrusions, or gate burrs. Mold flash, protrusions, or gate burrs shall not exceed 0.006 (0,15) each side.  
 D. Body width does not include interlead flash. Interlead flash shall not exceed 0.017 (0,43) each side.  
 E. Reference JEDEC MS-012 variation AA.

D (R-PDSO-G8)

PLASTIC SMALL OUTLINE

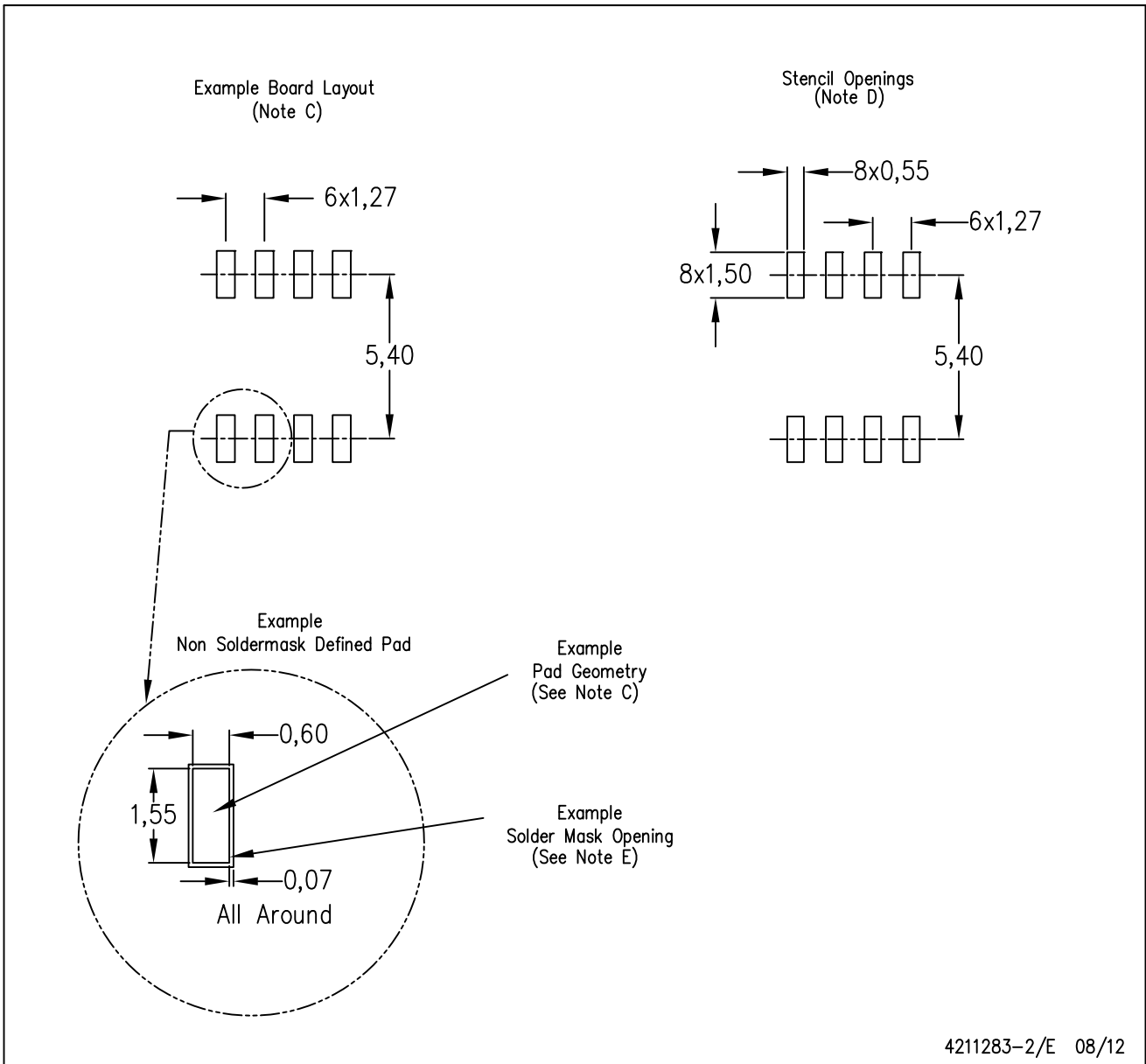

4211283-2/E 08/12

- NOTES:
- A. All linear dimensions are in millimeters.
  - B. This drawing is subject to change without notice.
  - C. Publication IPC-7351 is recommended for alternate designs.
  - D. Laser cutting apertures with trapezoidal walls and also rounding corners will offer better paste release. Customers should contact their board assembly site for stencil design recommendations. Refer to IPC-7525 for other stencil recommendations.
  - E. Customers should contact their board fabrication site for solder mask tolerances between and around signal pads.

## IMPORTANT NOTICE

Texas Instruments Incorporated and its subsidiaries (TI) reserve the right to make corrections, enhancements, improvements and other changes to its semiconductor products and services per JESD46, latest issue, and to discontinue any product or service per JESD48, latest issue. Buyers should obtain the latest relevant information before placing orders and should verify that such information is current and complete. All semiconductor products (also referred to herein as "components") are sold subject to TI's terms and conditions of sale supplied at the time of order acknowledgment.

TI warrants performance of its components to the specifications applicable at the time of sale, in accordance with the warranty in TI's terms and conditions of sale of semiconductor products. Testing and other quality control techniques are used to the extent TI deems necessary to support this warranty. Except where mandated by applicable law, testing of all parameters of each component is not necessarily performed.

TI assumes no liability for applications assistance or the design of Buyers' products. Buyers are responsible for their products and applications using TI components. To minimize the risks associated with Buyers' products and applications, Buyers should provide adequate design and operating safeguards.

TI does not warrant or represent that any license, either express or implied, is granted under any patent right, copyright, mask work right, or other intellectual property right relating to any combination, machine, or process in which TI components or services are used. Information published by TI regarding third-party products or services does not constitute a license to use such products or services or a warranty or endorsement thereof. Use of such information may require a license from a third party under the patents or other intellectual property of the third party, or a license from TI under the patents or other intellectual property of TI.

Reproduction of significant portions of TI information in TI data books or data sheets is permissible only if reproduction is without alteration and is accompanied by all associated warranties, conditions, limitations, and notices. TI is not responsible or liable for such altered documentation. Information of third parties may be subject to additional restrictions.

Resale of TI components or services with statements different from or beyond the parameters stated by TI for that component or service voids all express and any implied warranties for the associated TI component or service and is an unfair and deceptive business practice. TI is not responsible or liable for any such statements.

Buyer acknowledges and agrees that it is solely responsible for compliance with all legal, regulatory and safety-related requirements concerning its products, and any use of TI components in its applications, notwithstanding any applications-related information or support that may be provided by TI. Buyer represents and agrees that it has all the necessary expertise to create and implement safeguards which anticipate dangerous consequences of failures, monitor failures and their consequences, lessen the likelihood of failures that might cause harm and take appropriate remedial actions. Buyer will fully indemnify TI and its representatives against any damages arising out of the use of any TI components in safety-critical applications.

In some cases, TI components may be promoted specifically to facilitate safety-related applications. With such components, TI's goal is to help enable customers to design and create their own end-product solutions that meet applicable functional safety standards and requirements. Nonetheless, such components are subject to these terms.

No TI components are authorized for use in FDA Class III (or similar life-critical medical equipment) unless authorized officers of the parties have executed a special agreement specifically governing such use.

Only those TI components which TI has specifically designated as military grade or "enhanced plastic" are designed and intended for use in military/aerospace applications or environments. Buyer acknowledges and agrees that any military or aerospace use of TI components which have **not** been so designated is solely at the Buyer's risk, and that Buyer is solely responsible for compliance with all legal and regulatory requirements in connection with such use.

TI has specifically designated certain components as meeting ISO/TS16949 requirements, mainly for automotive use. In any case of use of non-designated products, TI will not be responsible for any failure to meet ISO/TS16949.

### Products

Audio	<a href="http://www.ti.com/audio">www.ti.com/audio</a>
Amplifiers	<a href="http://amplifier.ti.com">amplifier.ti.com</a>
Data Converters	<a href="http://dataconverter.ti.com">dataconverter.ti.com</a>
DLP® Products	<a href="http://www.dlp.com">www.dlp.com</a>
DSP	<a href="http://dsp.ti.com">dsp.ti.com</a>
Clocks and Timers	<a href="http://www.ti.com/clocks">www.ti.com/clocks</a>
Interface	<a href="http://interface.ti.com">interface.ti.com</a>
Logic	<a href="http://logic.ti.com">logic.ti.com</a>
Power Mgmt	<a href="http://power.ti.com">power.ti.com</a>
Microcontrollers	<a href="http://microcontroller.ti.com">microcontroller.ti.com</a>
RFID	<a href="http://www.ti-rfid.com">www.ti-rfid.com</a>
OMAP Applications Processors	<a href="http://www.ti.com/omap">www.ti.com/omap</a>
Wireless Connectivity	<a href="http://www.ti.com/wirelessconnectivity">www.ti.com/wirelessconnectivity</a>

### Applications

Automotive and Transportation	<a href="http://www.ti.com/automotive">www.ti.com/automotive</a>
Communications and Telecom	<a href="http://www.ti.com/communications">www.ti.com/communications</a>
Computers and Peripherals	<a href="http://www.ti.com/computers">www.ti.com/computers</a>
Consumer Electronics	<a href="http://www.ti.com/consumer-apps">www.ti.com/consumer-apps</a>
Energy and Lighting	<a href="http://www.ti.com/energy">www.ti.com/energy</a>
Industrial	<a href="http://www.ti.com/industrial">www.ti.com/industrial</a>
Medical	<a href="http://www.ti.com/medical">www.ti.com/medical</a>
Security	<a href="http://www.ti.com/security">www.ti.com/security</a>
Space, Avionics and Defense	<a href="http://www.ti.com/space-avionics-defense">www.ti.com/space-avionics-defense</a>
Video and Imaging	<a href="http://www.ti.com/video">www.ti.com/video</a>

### TI E2E Community

[e2e.ti.com](http://e2e.ti.com)