

## 50 $\mu$ V $V_{OS}$ , 0.25 $\mu$ V/ $^{\circ}$ C, 35 $\mu$ A CMOS OPERATIONAL AMPLIFIERS Zero-Drift Series

Check for Samples: [OPA330](#), [OPA2330](#), [OPA4330](#)

### FEATURES

- **UNMATCHED PRICE PERFORMANCE**
- **LOW OFFSET VOLTAGE: 50 $\mu$ V (max)**
- **ZERO DRIFT: 0.25 $\mu$ V/ $^{\circ}$ C (max)**
- **LOW NOISE: 1.1 $\mu$ V<sub>PP</sub>, 0.1Hz to 10Hz**
- **QUIESCENT CURRENT: 35 $\mu$ A (max)**
- **SUPPLY VOLTAGE: 1.8V to 5.5V**
- **RAIL-TO-RAIL INPUT/OUTPUT**
- **INTERNAL EMI FILTERING**
- **microSIZE PACKAGES: WCSP, SC70, QFN**

### APPLICATIONS

- **BATTERY-POWERED INSTRUMENTS**
- **TEMPERATURE MEASUREMENTS**
- **TRANSDUCER APPLICATIONS**
- **ELECTRONIC SCALES**
- **MEDICAL INSTRUMENTATION**
- **HANDHELD TEST EQUIPMENT**
- **CURRENT SENSE**

### DESCRIPTION

The OPA330 series of CMOS operational amplifiers offer precision performance at a very competitive price. These devices are members of the Zero-Drift family of amplifiers which use a proprietary auto-calibration technique to simultaneously provide low offset voltage (50 $\mu$ V max) and near-zero drift over time and temperature at only 35 $\mu$ A (max) of quiescent current. The OPA330 family features rail-to-rail input and output in addition to near flat 1/f noise, making this amplifier ideal for many applications and much easier to design into a system. These devices are optimized for low-voltage operation as low as +1.8V ( $\pm$ 0.9V) and up to +5.5V ( $\pm$ 2.75V).

The OPA330 (single version) is available in the WCSP-5, SC70-5, SOT23-5, and SOIC-8 packages. The OPA2330 (dual version) is offered in DFN-8 (3mm  $\times$  3mm), MSOP-8, and SOIC-8 packages. The OPA4330 is offered in the standard SOIC-14 and TSSOP-14 packages, as well as in the space-saving VQFN-14 package. All versions are specified for operation from  $-40^{\circ}$ C to  $+125^{\circ}$ C.

### PRODUCT FAMILY PACKAGE COMPARISON

DEVICE	NO OF CHANNELS	PACKAGE-LEADS						
		WCSP	SOIC	SOT23	SC70	MSOP	QFN	TSSOP
OPA330	1	5	8	5	5	–	–	–
OPA2330	2	–	8	–	–	8	8	–
OPA4330	4	–	14	–	–	–	14	14



Please be aware that an important notice concerning availability, standard warranty, and use in critical applications of Texas Instruments semiconductor products and disclaimers thereto appears at the end of this data sheet.

NanoStar, NanoFree are trademarks of Texas Instruments Incorporated.  
All other trademarks are the property of their respective owners.



This integrated circuit can be damaged by ESD. Texas Instruments recommends that all integrated circuits be handled with appropriate precautions. Failure to observe proper handling and installation procedures can cause damage.

ESD damage can range from subtle performance degradation to complete device failure. Precision integrated circuits may be more susceptible to damage because very small parametric changes could cause the device not to meet its published specifications.

### PACKAGE INFORMATION<sup>(1)</sup>

PRODUCT	PACKAGE-LEAD	PACKAGE DESIGNATOR	PACKAGE MARKING
OPA330	SOT23-5	DBV	OCFQ
	SC70-5	DCK	CHL
	SOIC-8	D	O330A
	WCSP-5	YFF	OEH
OPA2330	SOIC-8	D	O2330A
	DFN-8	DRB	OCGQ
	MSOP-8	DGK	OCGQ
OPA4330	SOIC-14	D	O4330A
	TSSOP-14	PW	O4330A
	QFN-14	RGY	4330A

(1) For the most current package and ordering information, see the Package Option Addendum at the end of this document, or visit the device product folder at [www.ti.com](http://www.ti.com).

### ABSOLUTE MAXIMUM RATINGS<sup>(1)</sup>

Over operating free-air temperature range, unless otherwise noted.

		OPA330, OPA2330, OPA4330	UNIT
Supply Voltage, $V_S = (V+) - (V-)$		+7	V
Signal Input Terminals, Voltage <sup>(2)</sup>		(V-) -0.3 to (V+) + 0.3	V
Signal Input Terminals, Current <sup>(2)</sup>		±10	mA
Output Short-Circuit <sup>(3)</sup>		Continuous	
Operating Temperature		-40 to +150	°C
Storage Temperature		-65 to +150	°C
Junction Temperature		+150	°C
ESD Ratings:	Human Body Model (HBM)	4000	V
	Charged Device Model (CDM)	1000	V
	Machine Model (MM)	400	V

- (1) Stresses above these ratings may cause permanent damage. Exposure to absolute maximum conditions for extended periods may degrade device reliability. These are stress ratings only, and functional operation of the device at these or any other conditions beyond those specified is not supported.
- (2) Input terminals are diode-clamped to the power-supply rails. Input signals that can swing more than 0.3V beyond the supply rails should be current limited to 10mA or less.
- (3) Short-circuit to ground, one amplifier per package.

**THERMAL INFORMATION**

THERMAL METRIC <sup>(1)</sup>	OPA330AID(R)	OPA330AIDBVR(T)	OPA330AIDCKR(T)	OPA330AIYFF	UNITS
	D	DBV	DCK	YFF	
	8 PINS	5 PINS	5 PINS	5 PINS	
$\theta_{JA}$ Junction-to-ambient thermal resistance	140.1	220.8	298.4	130	°C/W
$\theta_{JCtop}$ Junction-to-case (top) thermal resistance	89.8	97.5	65.4	54	
$\theta_{JB}$ Junction-to-board thermal resistance	80.6	61.7	97.1	51	
$\Psi_{JT}$ Junction-to-top characterization parameter	28.7	7.6	0.8	1	
$\Psi_{JB}$ Junction-to-board characterization parameter	80.1	61.1	95.5	50	
$\theta_{JCbot}$ Junction-to-case (bottom) thermal resistance	n/a	n/a	n/a	n/a	

(1) For more information about traditional and new thermal metrics, see the *IC Package Thermal Metrics* application report, [SPRA953](#).

**THERMAL INFORMATION**

THERMAL METRIC <sup>(1)</sup>	OPA2330AID(R)	OPA2330AIDGKR(T)	OPA2330AIDRBR(T)	UNITS
	D	DGK	DRB	
	8 PINS	8 PINS	8 PINS	
$\theta_{JA}$ Junction-to-ambient thermal resistance	124.0	180.3	46.7	°C/W
$\theta_{JCtop}$ Junction-to-case (top) thermal resistance	73.7	48.1	26.3	
$\theta_{JB}$ Junction-to-board thermal resistance	64.4	100.9	22.2	
$\Psi_{JT}$ Junction-to-top characterization parameter	18.0	2.4	1.6	
$\Psi_{JB}$ Junction-to-board characterization parameter	63.9	99.3	22.3	
$\theta_{JCbot}$ Junction-to-case (bottom) thermal resistance	n/a	n/a	10.1	

(1) For more information about traditional and new thermal metrics, see the *IC Package Thermal Metrics* application report, [SPRA953](#).

**THERMAL INFORMATION**

THERMAL METRIC <sup>(1)</sup>	OPA4330AID	OPA4330AIPW	OPA4330AIRGY	UNITS
	D	PW	RGY	
	14 PINS	14 PINS	14 PINS	
$\theta_{JA}$ Junction-to-ambient thermal resistance	83.8	120.8	49.2	°C/W
$\theta_{JCtop}$ Junction-to-case (top) thermal resistance	70.7	34.3	75.3	
$\theta_{JB}$ Junction-to-board thermal resistance	59.5	62.8	61.9	
$\Psi_{JT}$ Junction-to-top characterization parameter	11.6	1.0	1.2	
$\Psi_{JB}$ Junction-to-board characterization parameter	37.7	56.5	19.3	
$\theta_{JCbot}$ Junction-to-case (bottom) thermal resistance	n/a	n/a	4.6	

(1) For more information about traditional and new thermal metrics, see the *IC Package Thermal Metrics* application report, [SPRA953](#).

## ELECTRICAL CHARACTERISTICS: $V_S = +1.8V$ to $+5.5V$

**Boldface** limits apply over the specified temperature range,  $T_A = -40^\circ\text{C}$  to  $+125^\circ\text{C}$ .

At  $T_A = +25^\circ\text{C}$ ,  $R_L = 10\text{k}\Omega$  connected to midsupply,  $V_{CM} = V_{OUT} = \text{midsupply}$ , unless otherwise noted.

PARAMETER		TEST CONDITIONS	OPA330, OPA2330, OPA4330			UNIT
			MIN	TYP	MAX	
<b>OFFSET VOLTAGE</b>						
Input Offset Voltage	$V_{OS}$	$V_S = +5V$		8	50	$\mu\text{V}$
<b>vs Temperature</b>	<b><math>dV_{OS}/dT</math></b>			<b>0.02</b>	<b>0.25</b>	$\mu\text{V}/^\circ\text{C}$
<b>vs Power Supply</b>	<b>PSRR</b>	$V_S = +1.8V$ to $+5.5V$		<b>1</b>	<b>10</b>	$\mu\text{V}/\text{V}$
Long-Term Stability <sup>(1)</sup>				See <sup>(1)</sup>		
Channel Separation, dc				0.1		$\mu\text{V}/\text{V}$
<b>INPUT BIAS CURRENT</b>						
Input Bias Current	$I_B$			$\pm 200$	$\pm 500$	pA
Input Bias Current: OPA330YFF, OPA4330				$\pm 70$	$\pm 300$	pA
<b>over Temperature</b>				<b><math>\pm 300</math></b>		<b>pA</b>
Input Offset Current	$I_{OS}$			$\pm 400$	$\pm 1000$	pA
Input Offset Current: OPA330YFF, OPA4330				$\pm 140$	$\pm 600$	pA
<b>NOISE</b>						
Input Voltage Noise Density	$e_n$	$f = 1\text{kHz}$		55		$\text{nV}/\sqrt{\text{Hz}}$
Input Voltage Noise		$f = 0.01\text{Hz}$ to $1\text{Hz}$		0.3		$\mu\text{V}_{PP}$
Input Voltage Noise		$f = 0.1\text{Hz}$ to $10\text{Hz}$		1.1		$\mu\text{V}_{PP}$
Input Current Noise	$i_n$	$f = 10\text{Hz}$		100		$\text{fA}/\sqrt{\text{Hz}}$
<b>INPUT VOLTAGE RANGE</b>						
Common-Mode Voltage Range	$V_{CM}$		$(V-) - 0.1$		$(V+) + 0.1$	V
<b>Common-Mode Rejection Ratio</b>	<b>CMRR</b>	$(V-) - 0.1V < V_{CM} < (V+) + 0.1V$	<b>100</b>	<b>115</b>		<b>dB</b>
<b>Common-Mode Rejection Ratio: OPA330YFF, OPA4330</b>		$(V-) - 0.1V < V_{CM} < (V+) + 0.1V, V_S = 5.5V$	<b>100</b>	<b>115</b>		<b>dB</b>
<b>INPUT CAPACITANCE</b>						
Differential				2		pF
Common-Mode				4		pF
<b>OPEN-LOOP GAIN</b>						
Open-Loop Voltage Gain	$A_{OL}$	$(V-) + 100\text{mV} < V_O < (V+) - 100\text{mV}, R_L = 10\text{k}\Omega$	<b>100</b>	<b>115</b>		<b>dB</b>
<b>FREQUENCY RESPONSE</b>						
Gain-Bandwidth Product	GBW	$C_L = 100\text{pF}$		350		kHz
Slew Rate	SR	$G = +1$		0.16		$\text{V}/\mu\text{s}$
<b>OUTPUT</b>						
<b>Voltage Output Swing from Rail</b>				<b>30</b>	<b>100</b>	<b>mV</b>
Short-Circuit Current	$I_{SC}$			$\pm 5$		mA
Capacitive Load Drive	$C_L$		See <a href="#">Typical Characteristics</a>			
Open-Loop Output Impedance		$f = 350\text{kHz}, I_O = 0$		2		k $\Omega$
<b>POWER SUPPLY</b>						
Specified Voltage Range	$V_S$		1.8		5.5	V
<b>Quiescent Current Per Amplifier</b>	<b><math>I_Q</math></b>	<b><math>I_O = 0</math></b>		<b>21</b>	<b>35</b>	<b><math>\mu\text{A}</math></b>
Turn-On Time		$V_S = +5V$		100		$\mu\text{s}$

(1) 300-hour life test at  $+150^\circ\text{C}$  demonstrated randomly distributed variation of approximately  $1\mu\text{V}$ .

**ELECTRICAL CHARACTERISTICS:  $V_S = +1.8V$  to  $+5.5V$  (continued)**

**Boldface** limits apply over the specified temperature range,  $T_A = -40^{\circ}C$  to  $+125^{\circ}C$ .

At  $T_A = +25^{\circ}C$ ,  $R_L = 10k\Omega$  connected to midsupply,  $V_{CM} = V_{OUT} =$  midsupply, unless otherwise noted.

PARAMETER	TEST CONDITIONS	OPA330, OPA2330, OPA4330			UNIT
		MIN	TYP	MAX	
<b>TEMPERATURE RANGE</b>					
Specified Range		-40		+125	$^{\circ}C$
Operating Range		-40		+150	$^{\circ}C$
Storage Range		-65		+150	$^{\circ}C$
Thermal Resistance	$\theta_{JA}$				$^{\circ}C/W$
	SOT23-5		200		$^{\circ}C/W$
	MSOP-8, SOIC-8, TSSOP-14		150		$^{\circ}C/W$
	DFN-8		50		$^{\circ}C/W$
	SC70-5		250		$^{\circ}C/W$
	WCSP-5		130		$^{\circ}C/W$

**PIN CONFIGURATIONS**

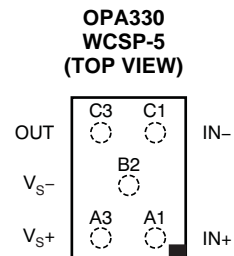
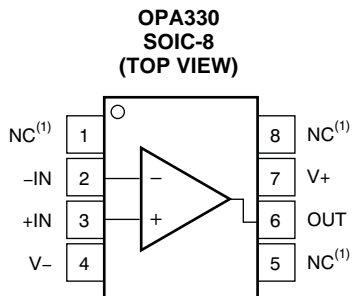
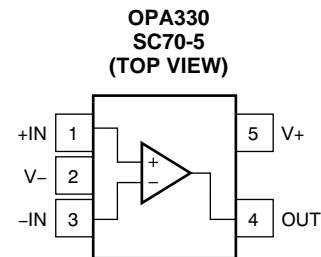
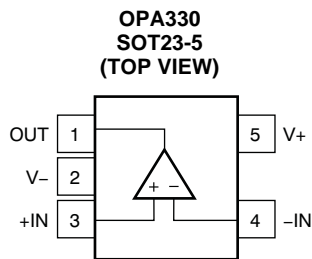

(1) NC denotes no internal connection.

**PIN CONFIGURATIONS, CONTINUED**

**OPA2330  
SOIC-8, MSOP-8  
(TOP VIEW)**

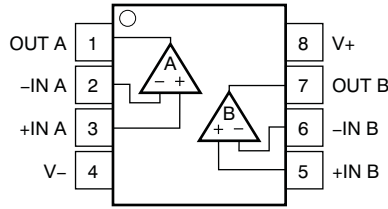

**OPA2330  
DFN-8  
(TOP VIEW)**

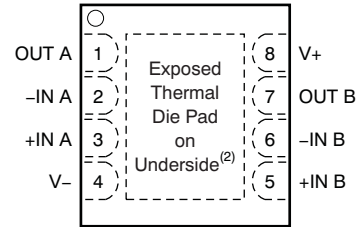

**OPA4330  
SOIC-14  
(TOP VIEW)**

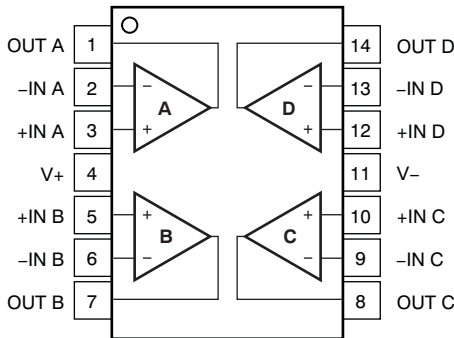

**OPA4330  
QFN-14  
(TOP VIEW)**

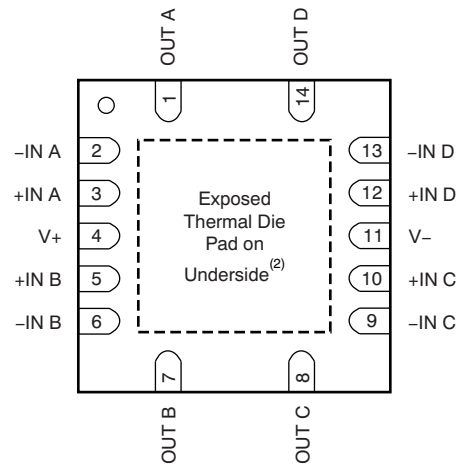

**OPA4330  
TSSOP-14  
(TOP VIEW)**

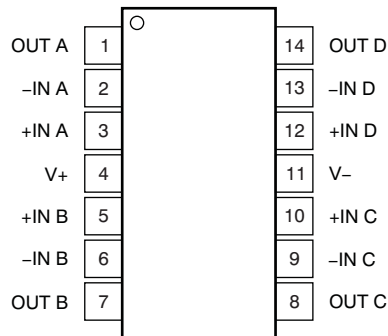

(2) Connect thermal die pad to V-.

### TYPICAL CHARACTERISTICS

At  $T_A = +25^\circ\text{C}$ ,  $C_L = 0\text{pF}$ ,  $R_L = 10\text{k}\Omega$  connected to midsupply,  $V_{CM} = V_{OUT} = \text{midsupply}$ , unless otherwise noted.

**OFFSET VOLTAGE PRODUCTION DISTRIBUTION**

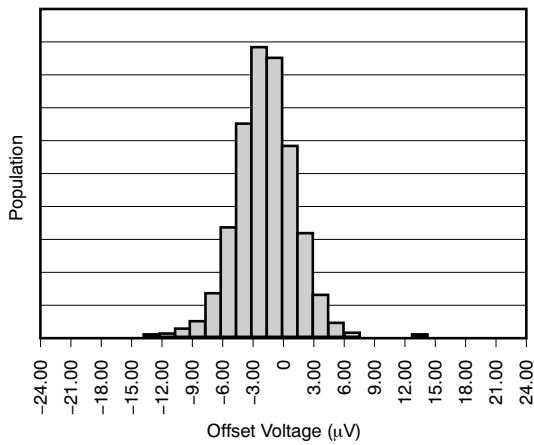

Figure 1.

**OPEN-LOOP GAIN vs FREQUENCY**

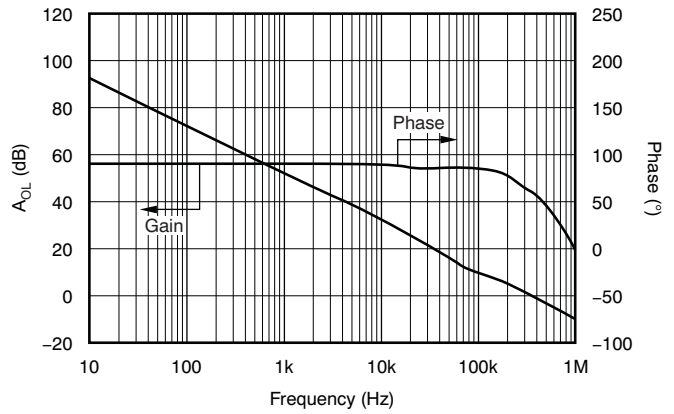

Figure 2.

**COMMON-MODE REJECTION RATIO vs FREQUENCY**

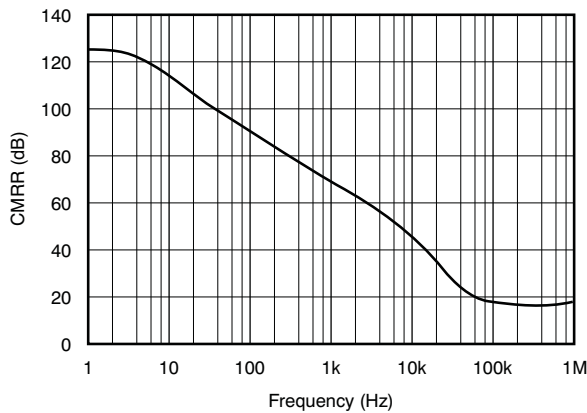

Figure 3.

**POWER-SUPPLY REJECTION RATIO vs FREQUENCY**

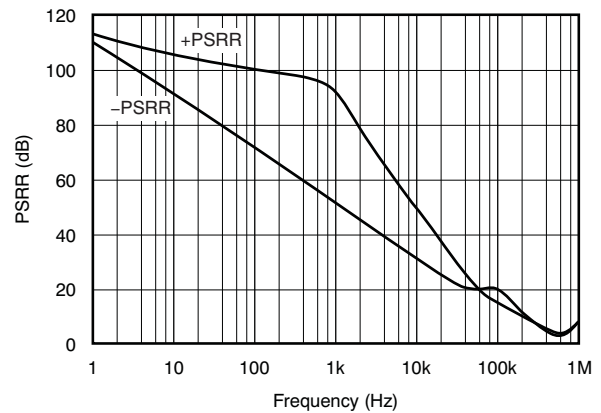

Figure 4.

**OUTPUT VOLTAGE SWING vs OUTPUT CURRENT**

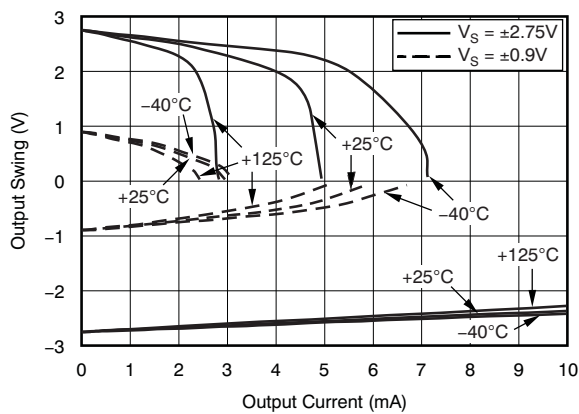

Figure 5.

**INPUT BIAS CURRENT vs COMMON-MODE VOLTAGE**

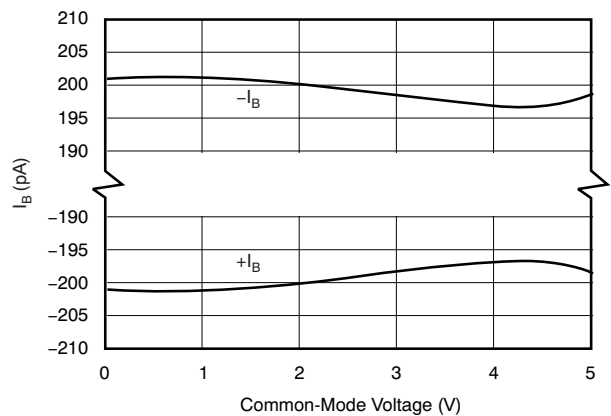

Figure 6.

### TYPICAL CHARACTERISTICS (continued)

At  $T_A = +25^\circ\text{C}$ ,  $C_L = 0\text{pF}$ ,  $R_L = 10\text{k}\Omega$  connected to midsupply,  $V_{CM} = V_{OUT} = \text{midsupply}$ , unless otherwise noted.

**INPUT BIAS CURRENT vs TEMPERATURE**

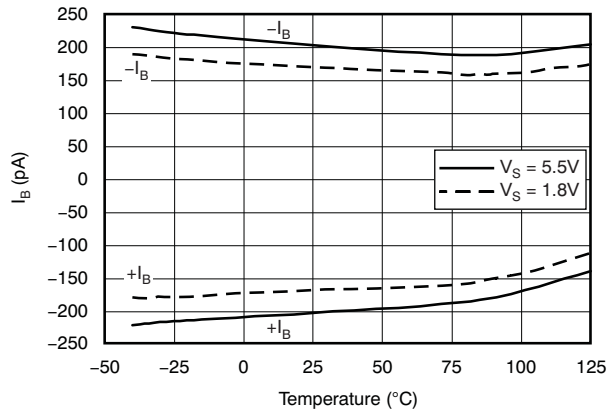

Figure 7.

**QUIESCENT CURRENT vs TEMPERATURE**

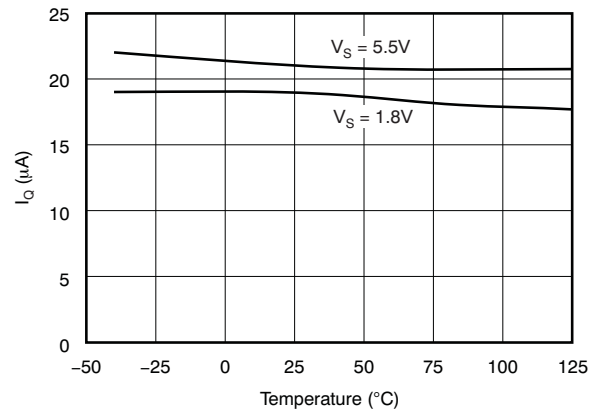

Figure 8.

**LARGE-SIGNAL STEP RESPONSE**

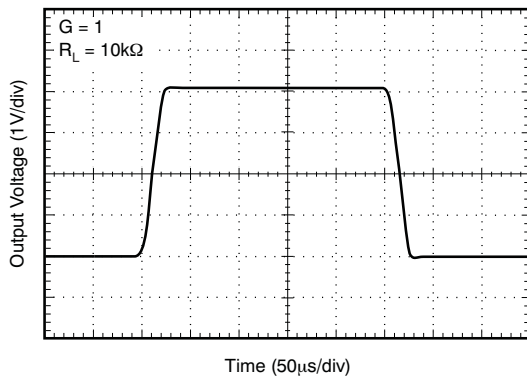

Figure 9.

**SMALL-SIGNAL STEP RESPONSE**

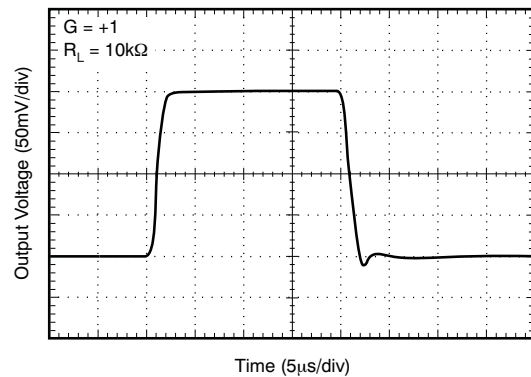

Figure 10.

**POSITIVE OVER-VOLTAGE RECOVERY**

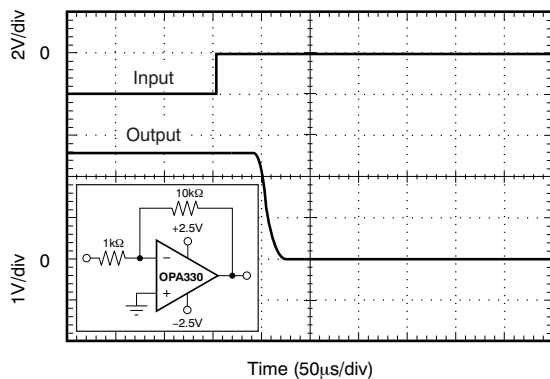

Figure 11.

**NEGATIVE OVER-VOLTAGE RECOVERY**

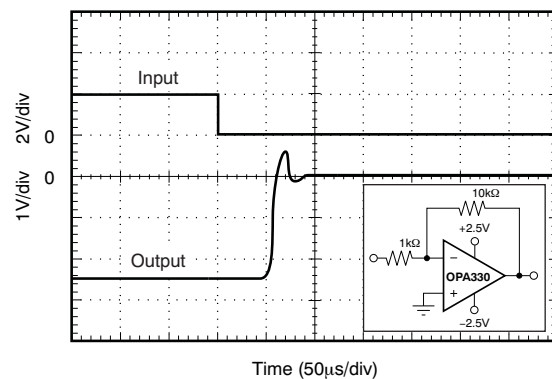

Figure 12.

**TYPICAL CHARACTERISTICS (continued)**

At  $T_A = +25^\circ\text{C}$ ,  $C_L = 0\text{pF}$ ,  $R_L = 10\text{k}\Omega$  connected to midsupply,  $V_{CM} = V_{OUT} = \text{midsupply}$ , unless otherwise noted.

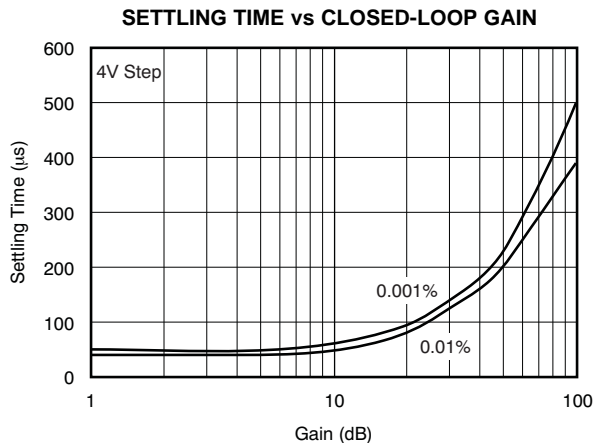

Figure 13.



Figure 14.

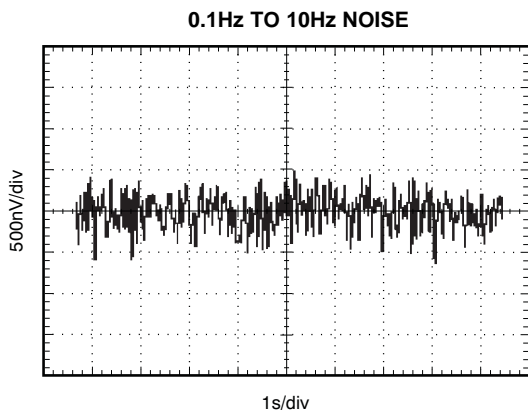

Figure 15.

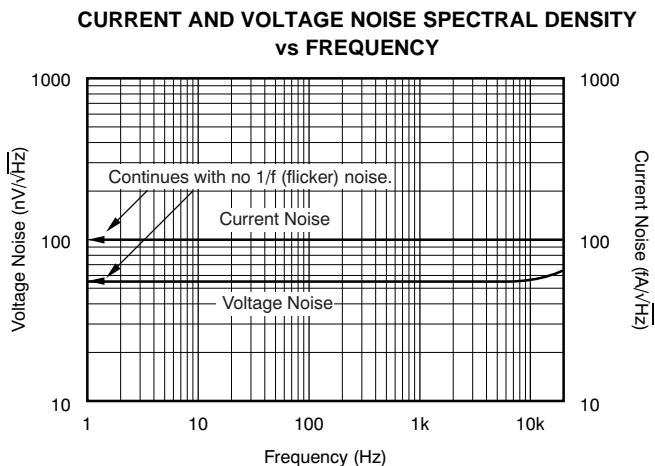

Figure 16.

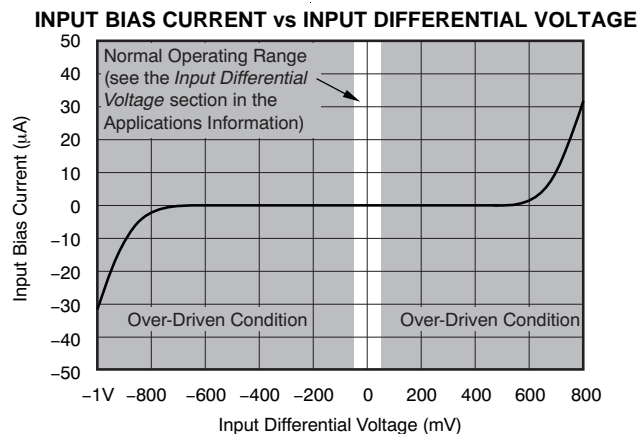

Figure 17.

## APPLICATIONS INFORMATION

The OPA330, OPA2330, and OPA4330 are unity-gain stable, precision operational amplifiers free from unexpected output and phase reversal. The use of proprietary Zero-Drift circuitry gives the benefit of low input offset voltage over time and temperature, as well as lowering the 1/f noise component. As a result of the high PSRR, these devices work well in applications that run directly from battery power without regulation. The OPA330 family is optimized for low-voltage, single-supply operation. These miniature, high-precision, low quiescent current amplifiers offer high-impedance inputs that have a common-mode range 100mV beyond the supplies and a rail-to-rail output that swings within 100mV of the supplies under normal test conditions. The OPA330 series are precision amplifiers for cost-sensitive applications.

### OPERATING VOLTAGE

The OPA330 series op amps can be used with single or dual supplies from an operating range of  $V_S = +1.8V (\pm 0.9V)$  up to  $+5.5V (\pm 2.75V)$ . Supply voltages greater than  $+7V$  can permanently damage the device. See the [Absolute Maximum Ratings](#) table. Key parameters that vary over the supply voltage or temperature range are shown in the [Typical Characteristics](#) section of this data sheet.

### INPUT VOLTAGE

The OPA330, OPA2330, and OPA4330 input common-mode voltage range extends 0.1V beyond the supply rails. The OPA330 is designed to cover the full range without the troublesome transition region found in some other rail-to-rail amplifiers.

Typically, input bias current is about 200pA; however, input voltages exceeding the power supplies can cause excessive current to flow into or out of the input pins. Momentary voltages greater than the power supply can be tolerated if the input current is limited to 10mA. This limitation is easily accomplished with an input resistor, as shown in [Figure 18](#).

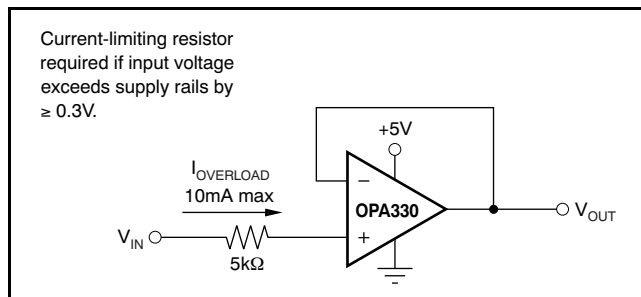

Figure 18. Input Current Protection

### INPUT DIFFERENTIAL VOLTAGE

The typical input bias current of the OPA330 during normal operation is approximately 200pA. In over-driven conditions, the bias current can increase significantly (see [Figure 17](#)). The most common cause of an over-driven condition occurs when the op amp is outside of the linear range of operation. When the output of the op amp is driven to one of the supply rails the feedback loop requirements cannot be satisfied and a differential input voltage develops across the input pins. This differential input voltage results in activation of parasitic diodes inside the front end input chopping switches that combine with 10kΩ electromagnetic interference (EMI) filter resistors to create the equivalent circuit shown in [Figure 19](#). Notice that the input bias current remains within specification within the linear region.

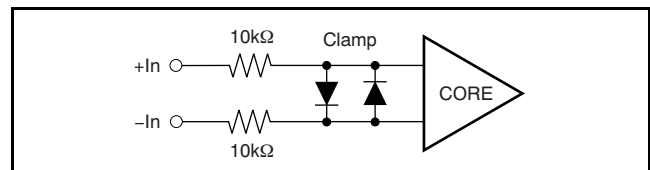

Figure 19. Equivalent Input Circuit

### INTERNAL OFFSET CORRECTION

The OPA330, OPA2330, and OPA4330 op amps use an auto-calibration technique with a time-continuous 125kHz op amp in the signal path. This amplifier is zero-corrected every 8μs using a proprietary technique. Upon power-up, the amplifier requires approximately 100μs to achieve specified  $V_{OS}$  accuracy. This design has no aliasing or flicker noise.

### EMI SUSCEPTIBILITY AND INPUT FILTERING

Operational amplifiers vary in their susceptibility to EMI. If conducted EMI enters the operational amplifier, the dc offset observed at the amplifier output may shift from its nominal value while the EMI is present. This shift is a result of signal rectification associated with the internal semiconductor junctions. While all operational amplifier pin functions can be affected by EMI, the input pins are likely to be the most susceptible. The OPA330 operational amplifier family incorporates an internal input low-pass filter that reduces the amplifier response to EMI. Both common-mode and differential mode filtering are provided by the input filter. The filter is designed for a cutoff frequency of approximately 8MHz (–3dB), with a roll-off of 20dB per decade.

## ACHIEVING OUTPUT SWING TO THE OP AMP NEGATIVE RAIL

Some applications require output voltage swings from 0V to a positive full-scale voltage (such as +2.5V) with excellent accuracy. With most single-supply op amps, problems arise when the output signal approaches 0V, near the lower output swing limit of a single-supply op amp. A good single-supply op amp may swing close to single-supply ground, but will not reach ground. The output of the OPA330, OPA2330, and OPA4330 can be made to swing to ground, or slightly below, on a single-supply power source. To do so requires the use of another resistor and an additional, more negative, power supply than the op amp negative supply. A pull-down resistor may be connected between the output and the additional negative supply to pull the output down below the value that the output would otherwise achieve, as shown in Figure 20.

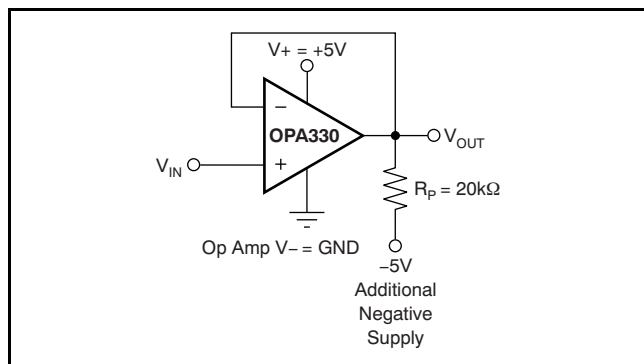

Figure 20. For  $V_{OUT}$  Range to Ground

The OPA330, OPA2330, and OPA4330 have an output stage that allows the output voltage to be pulled to its negative supply rail, or slightly below, using the technique previously described. This technique only works with some types of output stages. The OPA330, OPA2330, and OPA4330 have been characterized to perform with this technique; the recommended resistor value is approximately 20kΩ. Note that this configuration will increase the current consumption by several hundreds of microamps. Accuracy is excellent down to 0V and as low as -2mV. Limiting and nonlinearity occurs below -2mV, but excellent accuracy returns as the output is again driven above -2mV. Lowering the resistance of the pull-down resistor will allow the op amp to swing even further below the negative rail. Resistances as low as 10kΩ can be used to achieve excellent accuracy down to -10mV.

## APPLICATION CIRCUITS

Figure 21 shows the basic configuration for a bridge amplifier.

A low-side current shunt monitor is shown in Figure 22.

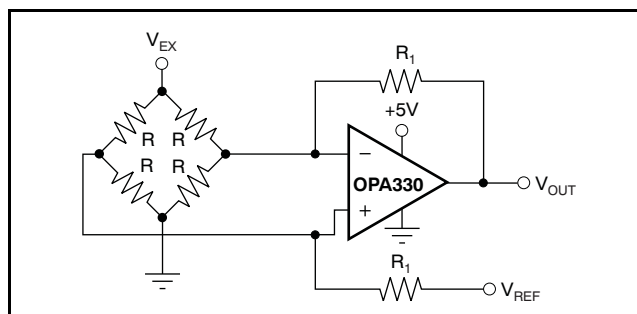
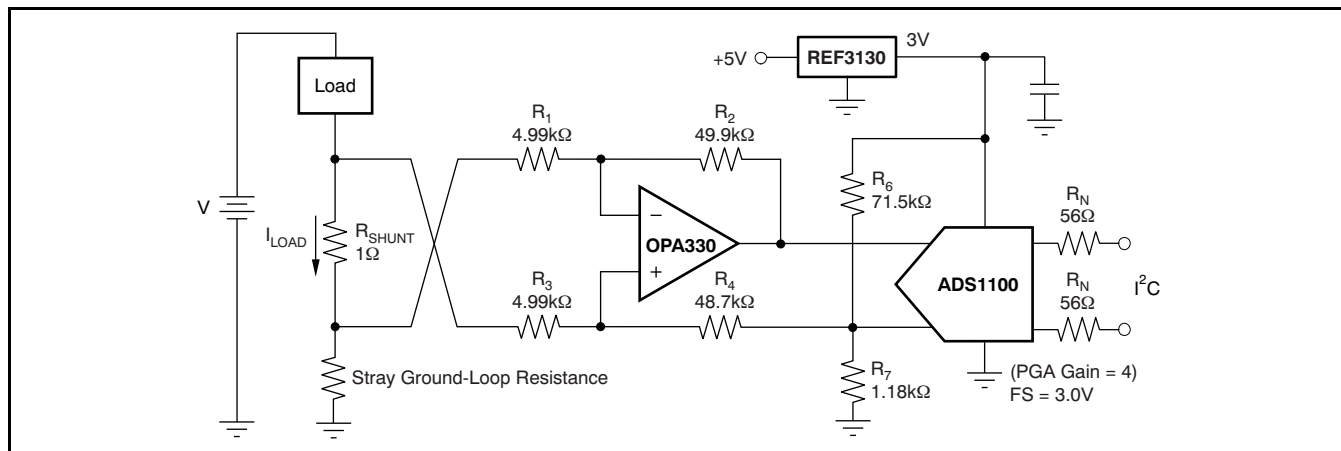

Figure 21. Single Op Amp Bridge Amplifier



NOTE: 1% resistors provide adequate common-mode rejection at small ground-loop errors.

Figure 22. Low-Side Current Monitor

$R_N$  are operational resistors used to isolate the [ADS1100](#) from the noise of the digital I<sup>2</sup>C bus. Because the ADS1100 is a 16-bit converter, a precise reference is essential for maximum accuracy. If absolute accuracy is not required, and the 5V power supply is sufficiently stable, the [REF3130](#) may be omitted.

[Figure 23](#) shows the OPA330 in a typical thermistor circuit.

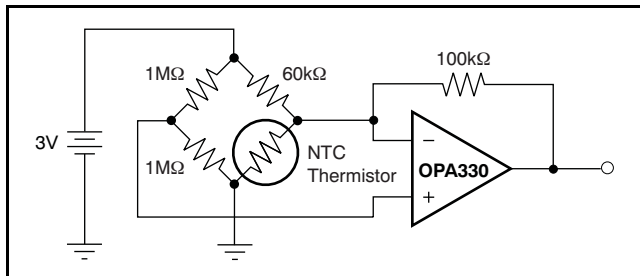

**Figure 23. Thermistor Measurement**

## GENERAL LAYOUT GUIDELINES

Attention to good layout practice is always recommended. Keep traces short and, when possible, use a printed circuit board (PCB) ground plane with surface-mount components placed as close to the device pins as possible. Place a 0.1μF capacitor closely across the supply pins. These guidelines should be applied throughout the analog circuit to improve performance and provide benefits such as reducing the electromagnetic interference (EMI) susceptibility.

For lowest offset voltage and precision performance, circuit layout and mechanical conditions should be optimized. Avoid temperature gradients that create thermoelectric (Seebeck) effects in the thermocouple junctions formed from connecting dissimilar conductors. These thermally-generated potentials can be made to cancel by assuring they are equal on both input terminals. Other layout and design considerations include:

- Use low thermoelectric-coefficient conditions (avoid dissimilar metals).
- Thermally isolate components from power supplies or other heat sources.
- Shield op amp and input circuitry from air currents, such as cooling fans.

Following these guidelines reduces the likelihood of junctions being at different temperatures, which can cause thermoelectric voltages of 0.1μV/°C or higher, depending on materials used.

## OPA330 WCSP

The OPA330 YFF package is a lead- (Pb-) free, die-level, wafer chip-scale package (WCSP). Unlike devices that are in plastic packages, these devices have no molding compound, lead frame, wire bonds, or leads. Using standard surface-mount assembly procedures, the WCSP can be mounted to a printed circuit board (PCB) without additional underfill. [Figure 24](#) and [Figure 25](#) detail the pinout and package marking, respectively. See the *NanoStar™ and NanoFree™ 300μm Solder Bump WCSP Application Note (SBVA017)* for more detailed information on package characteristics and PCB design.

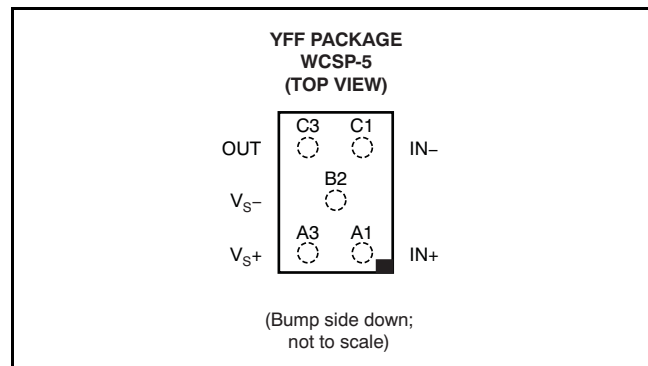

**Figure 24. WCSP Pin Description**

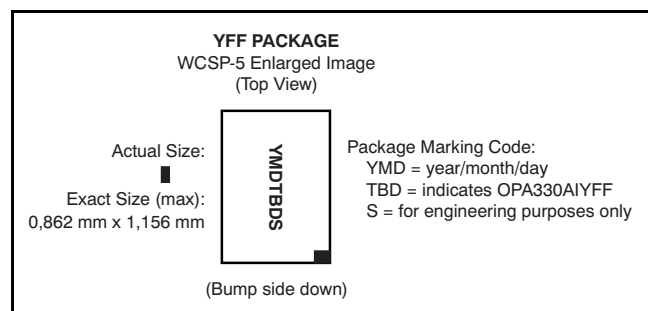

**Figure 25. YFF Package Marking**

## PHOTOSENSITIVITY

Although the OPA330 YFF package has a protective backside coating that reduces the amount of light exposure on the die, unless fully shielded, ambient light can reach the active region of the device. Input bias current for the package is specified in the absence of light. Depending on the amount of light exposure in a given application, an increase in bias current, and possible increases in offset voltage should be expected. Fluorescent lighting may introduce noise or hum because of the time-varying light output. Best layout practices include end-product packaging that provides shielding from possible light sources during operation.

## QFN AND DFN PACKAGES

The OPA4330 is offered in a QFN package. The OPA2330 is available in a DFN-8 package (also known as SON), which is a QFN package with lead contacts on only two sides of the bottom of the package. These leadless, near-chip-scale packages maximize board space and enhance thermal and electrical characteristics through an exposed pad. QFN and DFN packages are physically small, have a smaller routing area, improved thermal performance, and improved electrical parasitics, with a pinout scheme that is consistent with other commonly-used packages, such as SOIC and MSOP. Additionally, the absence of external leads eliminates bent-lead issues.

The QFN and DFN package can be easily mounted using standard PCB assembly techniques. See Application Note *QFN/SON PCB Attachment (SLUA271)* and Application Report *Quad Flatpack No-Lead Logic Packages (SCBA017)*, both available for download at [www.ti.com](http://www.ti.com).

**The exposed leadframe die pad on the bottom of the package should be connected to V–.**

## QFN AND DFN LAYOUT GUIDELINES

The leadframe die pad should be soldered to a thermal pad on the PCB. A mechanical data sheet showing an example layout is attached at the end of this data sheet. Refinements to this layout may be required based on assembly process requirements. Mechanical drawings located at the end of this data sheet list the physical dimensions for the package and pad. The five holes in the landing pattern are optional, and are intended for use with thermal vias that connect the leadframe die pad to the heatsink area on the PCB.

Soldering the exposed pad significantly improves board-level reliability during temperature cycling, key push, package shear, and similar board-level tests. Even with applications that have low-power dissipation, the exposed pad must be soldered to the PCB to provide structural integrity and long-term reliability.

## REVISION HISTORY

NOTE: Page numbers for previous revisions may differ from page numbers in the current version.

Changes from Revision D (June 2010) to Revision E	Page
• Changed document status from Mixed Status to Production Data .....	1
• Deleted footnote 2 from the Package Information table .....	2
• Added remaining thermal information data .....	3

Changes from Revision C (October 2009) to Revision D	Page
• Added last <i>Applications</i> bullet .....	1
• Deleted footnote 1 from Product Family Package Comparison table .....	1
• Deleted footnote 2 and shading from all packages except QFN-14; moved WCSP-5, SOIC-14, and TSSOP-14 packages to Production Data status; and added package marking information to Package Information table .....	2
• Added <i>OPA330YFF</i> , <i>OPA4330</i> Input Bias Current parameter to Electrical Characteristics table .....	4
• Added Input Voltage Range, <i>OPA330YFF</i> , <i>OPA4330 Common-Mode Rejection Ratio</i> parameter to Electrical Characteristics table .....	4
• Moved TSSOP-14 thermal resistance to MSOP-8, SOIC-8 thermal resistance parameter in Electrical Characteristics table .....	5
• Deleted SOIC-14 and QFN-14 rows from Temperature Range section in Electrical Characteristics table .....	5

**PACKAGING INFORMATION**

Orderable Device	Status (1)	Package Type	Package Drawing	Pins	Package Qty	Eco Plan (2)	Lead/Ball Finish (6)	MSL Peak Temp (3)	Op Temp (°C)	Device Marking (4/5)	Samples
OPA2330AID	ACTIVE	SOIC	D	8	75	Green (RoHS & no Sb/Br)	CU NIPDAU	Level-1-260C-UNLIM	-40 to 125	O2330A	<a href="#">Samples</a>
OPA2330AIDGKR	ACTIVE	VSSOP	DGK	8	2500	Green (RoHS & no Sb/Br)	CU NIPDAUAG	Level-1-260C-UNLIM	-40 to 125	OCGQ	<a href="#">Samples</a>
OPA2330AIDGKRG4	ACTIVE	VSSOP	DGK	8	2500	Green (RoHS & no Sb/Br)	CU NIPDAUAG	Level-1-260C-UNLIM	-40 to 125	OCGQ	<a href="#">Samples</a>
OPA2330AIDGKT	ACTIVE	VSSOP	DGK	8	250	Green (RoHS & no Sb/Br)	CU NIPDAUAG	Level-1-260C-UNLIM	-40 to 125	OCGQ	<a href="#">Samples</a>
OPA2330AIDR	ACTIVE	SOIC	D	8	2500	Green (RoHS & no Sb/Br)	CU NIPDAU	Level-1-260C-UNLIM	-40 to 125	O2330A	<a href="#">Samples</a>
OPA2330AIDRBR	ACTIVE	SON	DRB	8	3000	Green (RoHS & no Sb/Br)	CU NIPDAU	Level-1-260C-UNLIM	-40 to 125	OCGQ	<a href="#">Samples</a>
OPA2330AIDRBRG4	ACTIVE	SON	DRB	8	3000	Green (RoHS & no Sb/Br)	CU NIPDAU	Level-1-260C-UNLIM	-40 to 125	OCGQ	<a href="#">Samples</a>
OPA2330AIDRBT	ACTIVE	SON	DRB	8	250	Green (RoHS & no Sb/Br)	CU NIPDAU	Level-1-260C-UNLIM	-40 to 125	OCGQ	<a href="#">Samples</a>
OPA2330AIDRBTG4	ACTIVE	SON	DRB	8	250	Green (RoHS & no Sb/Br)	CU NIPDAU	Level-1-260C-UNLIM	-40 to 125	OCGQ	<a href="#">Samples</a>
OPA2330AIDRG4	ACTIVE	SOIC	D	8	2500	Green (RoHS & no Sb/Br)	CU NIPDAU	Level-1-260C-UNLIM	-40 to 125	O2330A	<a href="#">Samples</a>
OPA330AID	ACTIVE	SOIC	D	8	75	Green (RoHS & no Sb/Br)	CU NIPDAU	Level-1-260C-UNLIM	-40 to 125	O330A	<a href="#">Samples</a>
OPA330AIDBVR	ACTIVE	SOT-23	DBV	5	3000	Green (RoHS & no Sb/Br)	CU NIPDAU	Level-1-260C-UNLIM	-40 to 125	OCFQ	<a href="#">Samples</a>
OPA330AIDBVRG4	ACTIVE	SOT-23	DBV	5	3000	Green (RoHS & no Sb/Br)	CU NIPDAU	Level-1-260C-UNLIM	-40 to 125	OCFQ	<a href="#">Samples</a>
OPA330AIDBVT	ACTIVE	SOT-23	DBV	5	250	Green (RoHS & no Sb/Br)	CU NIPDAU	Level-1-260C-UNLIM	-40 to 125	OCFQ	<a href="#">Samples</a>
OPA330AIDBVTG4	ACTIVE	SOT-23	DBV	5	250	Green (RoHS & no Sb/Br)	CU NIPDAU	Level-1-260C-UNLIM	-40 to 125	OCFQ	<a href="#">Samples</a>
OPA330AIDCKR	ACTIVE	SC70	DCK	5	3000	Green (RoHS & no Sb/Br)	CU NIPDAU	Level-1-260C-UNLIM	-40 to 125	CHL	<a href="#">Samples</a>
OPA330AIDCKRG4	ACTIVE	SC70	DCK	5	3000	Green (RoHS & no Sb/Br)	CU NIPDAU	Level-1-260C-UNLIM	-40 to 125	CHL	<a href="#">Samples</a>

Orderable Device	Status (1)	Package Type	Package Drawing	Pins	Package Qty	Eco Plan (2)	Lead/Ball Finish (6)	MSL Peak Temp (3)	Op Temp (°C)	Device Marking (4/5)	Samples
OPA330AIDCKT	ACTIVE	SC70	DCK	5	250	Green (RoHS & no Sb/Br)	CU NIPDAU	Level-1-260C-UNLIM	-40 to 125	CHL	<a href="#">Samples</a>
OPA330AIDCKTG4	ACTIVE	SC70	DCK	5	250	Green (RoHS & no Sb/Br)	CU NIPDAU	Level-1-260C-UNLIM	-40 to 125	CHL	<a href="#">Samples</a>
OPA330AIDR	ACTIVE	SOIC	D	8	2500	Green (RoHS & no Sb/Br)	CU NIPDAU	Level-1-260C-UNLIM	-40 to 125	O330A	<a href="#">Samples</a>
OPA330AIDRG4	ACTIVE	SOIC	D	8	2500	Green (RoHS & no Sb/Br)	CU NIPDAU	Level-1-260C-UNLIM	-40 to 125	O330A	<a href="#">Samples</a>
OPA330AIYFFR	ACTIVE	DSBGA	YFF	5	3000	Green (RoHS & no Sb/Br)	SNAGCU	Level-1-260C-UNLIM	-40 to 125	OEH	<a href="#">Samples</a>
OPA330AIYFFT	ACTIVE	DSBGA	YFF	5	250	Green (RoHS & no Sb/Br)	SNAGCU	Level-1-260C-UNLIM	-40 to 125	OEH	<a href="#">Samples</a>
OPA4330AID	ACTIVE	SOIC	D	14	50	Green (RoHS & no Sb/Br)	CU NIPDAU	Level-2-260C-1 YEAR	-40 to 125	O4330A	<a href="#">Samples</a>
OPA4330AIDR	ACTIVE	SOIC	D	14	2500	Green (RoHS & no Sb/Br)	CU NIPDAU	Level-2-260C-1 YEAR	-40 to 125	O4330A	<a href="#">Samples</a>
OPA4330AIPW	ACTIVE	TSSOP	PW	14	90	Green (RoHS & no Sb/Br)	CU NIPDAU	Level-2-260C-1 YEAR	-40 to 125	O4330A	<a href="#">Samples</a>
OPA4330AIPWR	ACTIVE	TSSOP	PW	14	2000	Green (RoHS & no Sb/Br)	CU NIPDAU	Level-2-260C-1 YEAR	-40 to 125	O4330A	<a href="#">Samples</a>
OPA4330AIRGYR	ACTIVE	VQFN	RGY	14	3000	Green (RoHS & no Sb/Br)	CU NIPDAU	Level-2-260C-1 YEAR	-40 to 125	4330A	<a href="#">Samples</a>
OPA4330AIRGYT	ACTIVE	VQFN	RGY	14	250	Green (RoHS & no Sb/Br)	CU NIPDAU	Level-2-260C-1 YEAR	-40 to 125	4330A	<a href="#">Samples</a>

(1) The marketing status values are defined as follows:

**ACTIVE:** Product device recommended for new designs.

**LIFEBUY:** TI has announced that the device will be discontinued, and a lifetime-buy period is in effect.

**NRND:** Not recommended for new designs. Device is in production to support existing customers, but TI does not recommend using this part in a new design.

**PREVIEW:** Device has been announced but is not in production. Samples may or may not be available.

**OBSELETE:** TI has discontinued the production of the device.

(2) Eco Plan - The planned eco-friendly classification: Pb-Free (RoHS), Pb-Free (RoHS Exempt), or Green (RoHS & no Sb/Br) - please check <http://www.ti.com/productcontent> for the latest availability information and additional product content details.

**TBD:** The Pb-Free/Green conversion plan has not been defined.

**Pb-Free (RoHS):** TI's terms "Lead-Free" or "Pb-Free" mean semiconductor products that are compatible with the current RoHS requirements for all 6 substances, including the requirement that lead not exceed 0.1% by weight in homogeneous materials. Where designed to be soldered at high temperatures, TI Pb-Free products are suitable for use in specified lead-free processes.

---

**Pb-Free (RoHS Exempt):** This component has a RoHS exemption for either 1) lead-based flip-chip solder bumps used between the die and package, or 2) lead-based die adhesive used between the die and leadframe. The component is otherwise considered Pb-Free (RoHS compatible) as defined above.

**Green (RoHS & no Sb/Br):** TI defines "Green" to mean Pb-Free (RoHS compatible), and free of Bromine (Br) and Antimony (Sb) based flame retardants (Br or Sb do not exceed 0.1% by weight in homogeneous material)

<sup>(3)</sup> MSL, Peak Temp. - The Moisture Sensitivity Level rating according to the JEDEC industry standard classifications, and peak solder temperature.

<sup>(4)</sup> There may be additional marking, which relates to the logo, the lot trace code information, or the environmental category on the device.

<sup>(5)</sup> Multiple Device Markings will be inside parentheses. Only one Device Marking contained in parentheses and separated by a "~" will appear on a device. If a line is indented then it is a continuation of the previous line and the two combined represent the entire Device Marking for that device.

<sup>(6)</sup> Lead/Ball Finish - Orderable Devices may have multiple material finish options. Finish options are separated by a vertical ruled line. Lead/Ball Finish values may wrap to two lines if the finish value exceeds the maximum column width.

**Important Information and Disclaimer:** The information provided on this page represents TI's knowledge and belief as of the date that it is provided. TI bases its knowledge and belief on information provided by third parties, and makes no representation or warranty as to the accuracy of such information. Efforts are underway to better integrate information from third parties. TI has taken and continues to take reasonable steps to provide representative and accurate information but may not have conducted destructive testing or chemical analysis on incoming materials and chemicals. TI and TI suppliers consider certain information to be proprietary, and thus CAS numbers and other limited information may not be available for release.

In no event shall TI's liability arising out of such information exceed the total purchase price of the TI part(s) at issue in this document sold by TI to Customer on an annual basis.

**TAPE AND REEL INFORMATION**

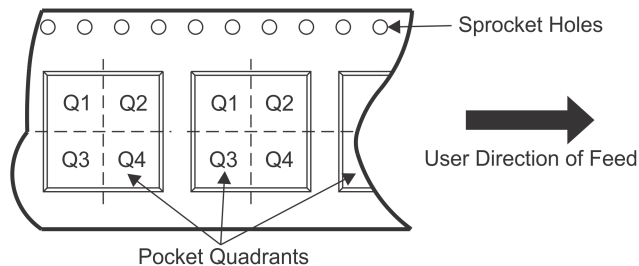
**QUADRANT ASSIGNMENTS FOR PIN 1 ORIENTATION IN TAPE**

\*All dimensions are nominal

Device	Package Type	Package Drawing	Pins	SPQ	Reel Diameter (mm)	Reel Width W1 (mm)	A0 (mm)	B0 (mm)	K0 (mm)	P1 (mm)	W (mm)	Pin1 Quadrant
OPA2330AIDGKR	VSSOP	DGK	8	2500	330.0	12.4	5.3	3.4	1.4	8.0	12.0	Q1
OPA2330AIDGKT	VSSOP	DGK	8	250	330.0	12.4	5.3	3.4	1.4	8.0	12.0	Q1
OPA2330AIDRBR	SON	DRB	8	3000	330.0	12.4	3.3	3.3	1.1	8.0	12.0	Q2
OPA2330AIDRBT	SON	DRB	8	250	180.0	12.4	3.3	3.3	1.1	8.0	12.0	Q2
OPA330AIDBVR	SOT-23	DBV	5	3000	178.0	9.0	3.23	3.17	1.37	4.0	8.0	Q3
OPA330AIDBVR	SOT-23	DBV	5	3000	179.0	8.4	3.2	3.2	1.4	4.0	8.0	Q3
OPA330AIDBVT	SOT-23	DBV	5	250	178.0	9.0	3.3	3.2	1.4	4.0	8.0	Q3
OPA330AIDCKR	SC70	DCK	5	3000	179.0	8.4	2.2	2.5	1.2	4.0	8.0	Q3
OPA330AIDCKT	SC70	DCK	5	250	179.0	8.4	2.2	2.5	1.2	4.0	8.0	Q3
OPA330AIDR	SOIC	D	8	2500	330.0	12.4	6.4	5.2	2.1	8.0	12.0	Q1
OPA330AIYFFR	DSBGA	YFF	5	3000	180.0	8.4	0.97	1.27	0.73	4.0	8.0	Q1
OPA330AIYFFT	DSBGA	YFF	5	250	180.0	8.4	0.97	1.27	0.73	4.0	8.0	Q1
OPA4330AIDR	SOIC	D	14	2500	330.0	16.4	6.5	9.0	2.1	8.0	16.0	Q1
OPA4330AIPWR	TSSOP	PW	14	2000	330.0	12.4	6.9	5.6	1.6	8.0	12.0	Q1
OPA4330AIRGYR	VQFN	RGY	14	3000	330.0	12.4	3.75	3.75	1.15	8.0	12.0	Q1
OPA4330AIRGYT	VQFN	RGY	14	250	180.0	12.4	3.75	3.75	1.15	8.0	12.0	Q1

**TAPE AND REEL BOX DIMENSIONS**

\*All dimensions are nominal

Device	Package Type	Package Drawing	Pins	SPQ	Length (mm)	Width (mm)	Height (mm)
OPA2330AIDGKR	VSSOP	DGK	8	2500	364.0	364.0	27.0
OPA2330AIDGKT	VSSOP	DGK	8	250	364.0	364.0	27.0
OPA2330AIDRBR	SON	DRB	8	3000	367.0	367.0	35.0
OPA2330AIDRBT	SON	DRB	8	250	210.0	185.0	35.0
OPA330AIDBVR	SOT-23	DBV	5	3000	180.0	180.0	18.0
OPA330AIDBVR	SOT-23	DBV	5	3000	203.0	203.0	35.0
OPA330AIDBVT	SOT-23	DBV	5	250	180.0	180.0	18.0
OPA330AIDCKR	SC70	DCK	5	3000	203.0	203.0	35.0
OPA330AIDCKT	SC70	DCK	5	250	203.0	203.0	35.0
OPA330AIDR	SOIC	D	8	2500	367.0	367.0	35.0
OPA330AIYFFR	DSBGA	YFF	5	3000	210.0	185.0	35.0
OPA330AIYFFT	DSBGA	YFF	5	250	210.0	185.0	35.0
OPA4330AIDR	SOIC	D	14	2500	367.0	367.0	38.0
OPA4330AIPWR	TSSOP	PW	14	2000	367.0	367.0	35.0
OPA4330AIRGYR	VQFN	RGY	14	3000	367.0	367.0	35.0
OPA4330AIRGYT	VQFN	RGY	14	250	210.0	185.0	35.0

DBV (R-PDSO-G5)

PLASTIC SMALL-OUTLINE PACKAGE

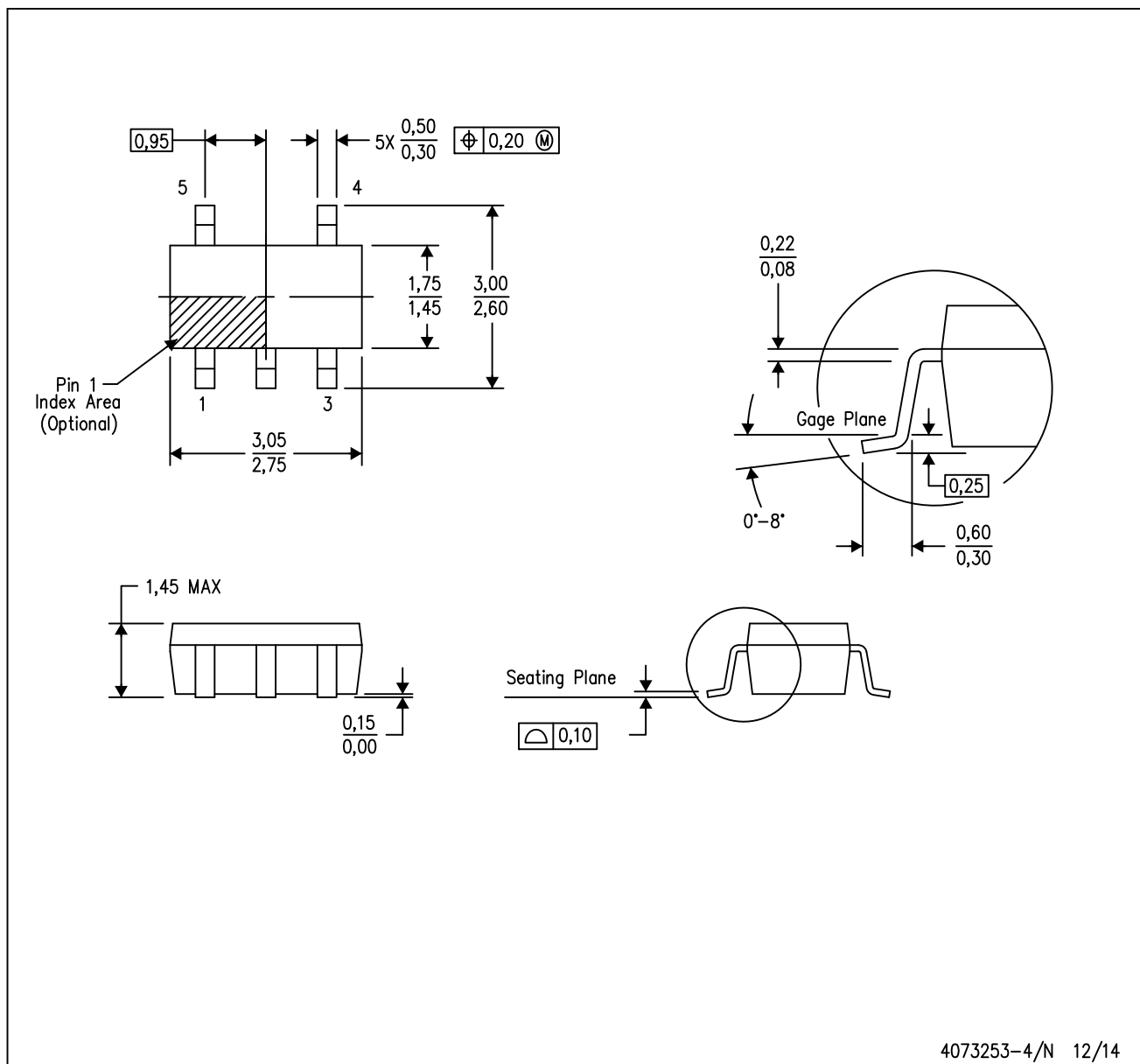

- NOTES:
- A. All linear dimensions are in millimeters.
  - B. This drawing is subject to change without notice.
  - C. Body dimensions do not include mold flash or protrusion. Mold flash and protrusion shall not exceed 0.15 per side.
  - D. Falls within JEDEC MO-178 Variation AA.

DBV (R-PDSO-G5)

PLASTIC SMALL OUTLINE



- NOTES:
- A. All linear dimensions are in millimeters.
  - B. This drawing is subject to change without notice.
  - C. Customers should place a note on the circuit board fabrication drawing not to alter the center solder mask defined pad.
  - D. Publication IPC-7351 is recommended for alternate designs.
  - E. Laser cutting apertures with trapezoidal walls and also rounding corners will offer better paste release. Customers should contact their board assembly site for stencil design recommendations. Example stencil design based on a 50% volumetric metal load solder paste. Refer to IPC-7525 for other stencil recommendations.

DCK (R-PDSO-G5)

PLASTIC SMALL-OUTLINE PACKAGE

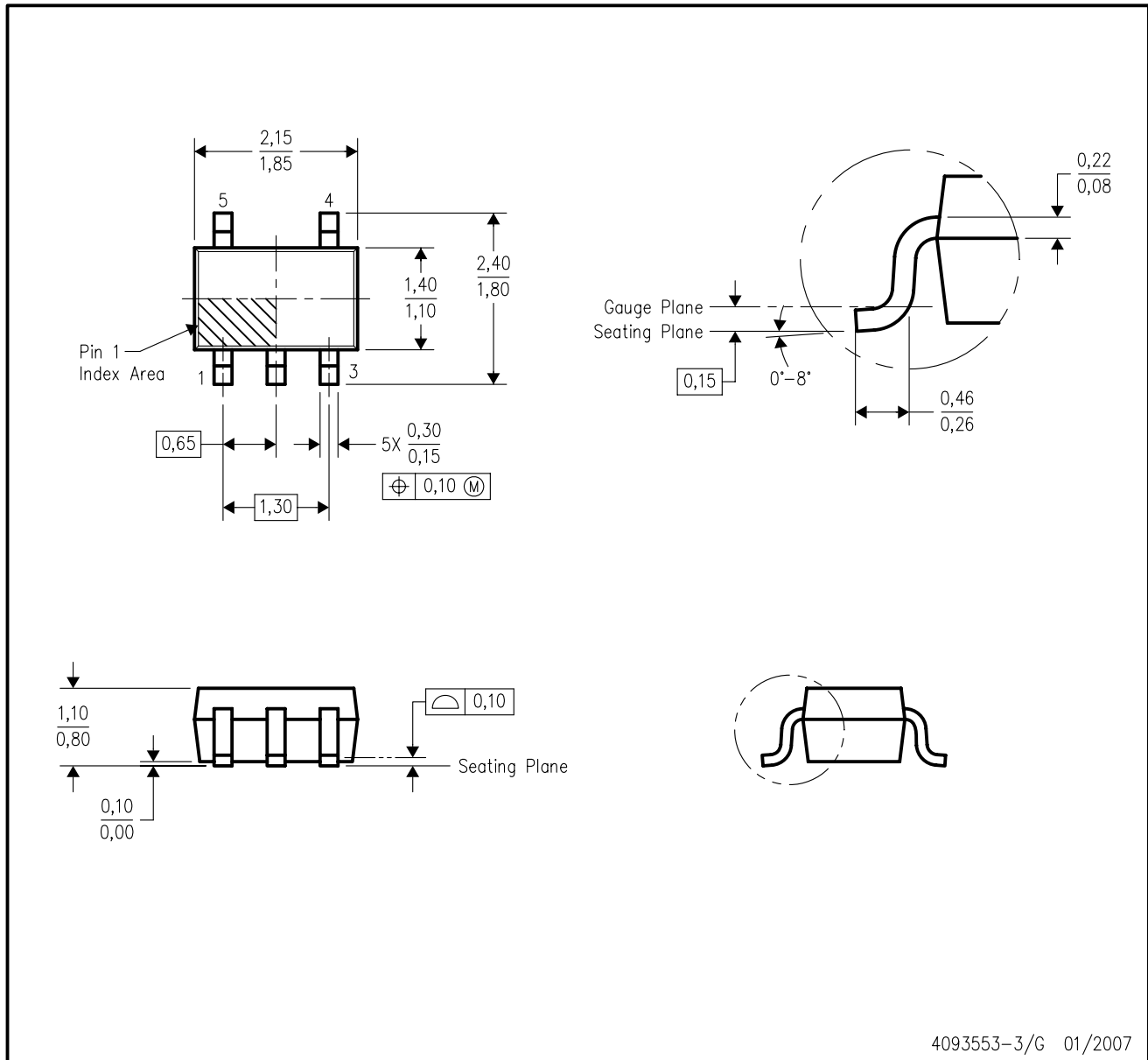

- NOTES:
- A. All linear dimensions are in millimeters.
  - B. This drawing is subject to change without notice.
  - C. Body dimensions do not include mold flash or protrusion. Mold flash and protrusion shall not exceed 0.15 per side.
  - D. Falls within JEDEC MO-203 variation AA.

DCK (R-PDSO-G5)

PLASTIC SMALL OUTLINE



- NOTES:
- All linear dimensions are in millimeters.
  - This drawing is subject to change without notice.
  - Customers should place a note on the circuit board fabrication drawing not to alter the center solder mask defined pad.
  - Publication IPC-7351 is recommended for alternate designs.
  - Laser cutting apertures with trapezoidal walls and also rounding corners will offer better paste release. Customers should contact their board assembly site for stencil design recommendations. Example stencil design based on a 50% volumetric metal load solder paste. Refer to IPC-7525 for other stencil recommendations.

DGK (S-PDSO-G8)

PLASTIC SMALL-OUTLINE PACKAGE

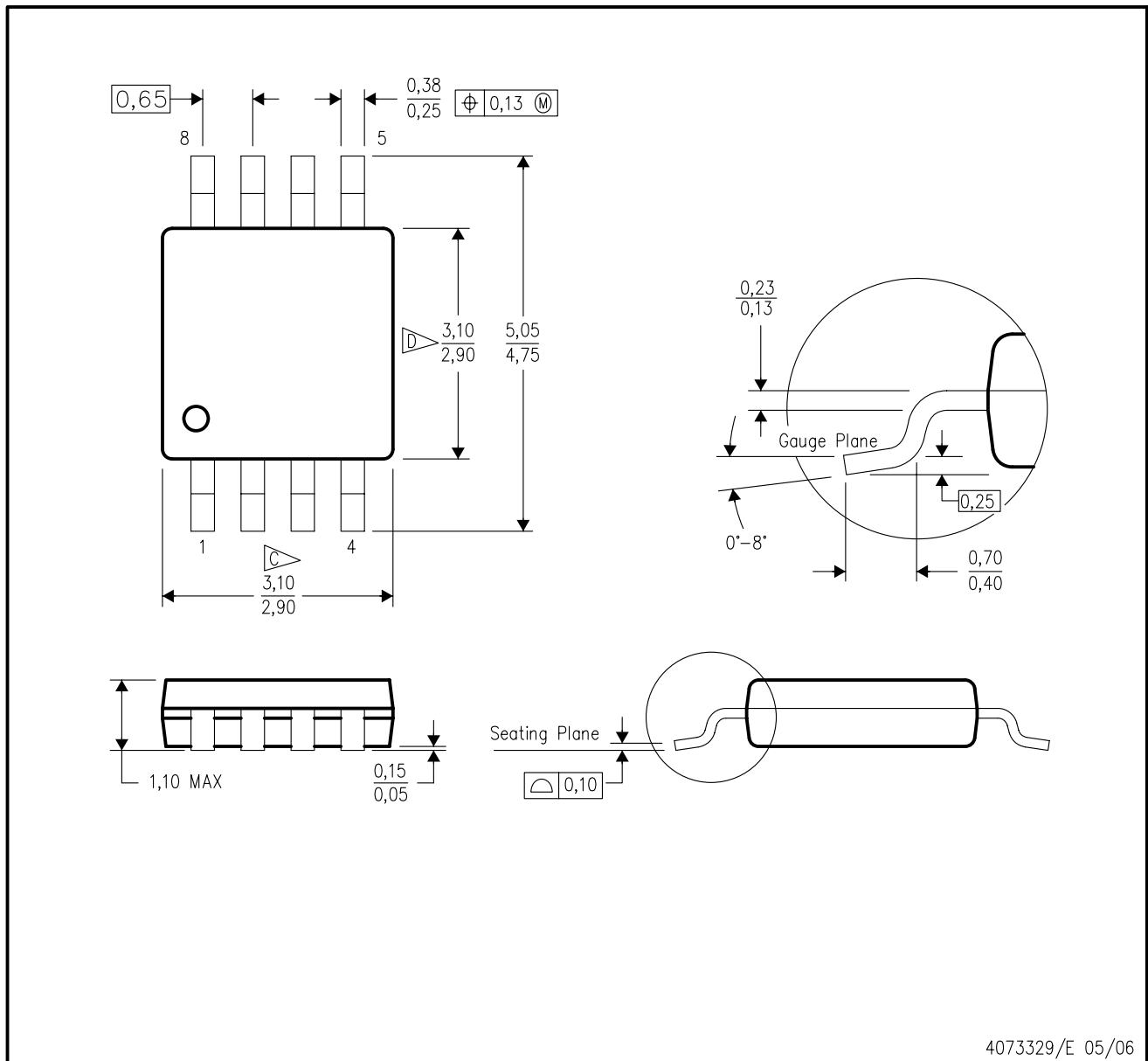

- NOTES:
- A. All linear dimensions are in millimeters.
  - B. This drawing is subject to change without notice.
  - C. Body length does not include mold flash, protrusions, or gate burrs. Mold flash, protrusions, or gate burrs shall not exceed 0.15 per end.
  - D. Body width does not include interlead flash. Interlead flash shall not exceed 0.50 per side.
  - E. Falls within JEDEC MO-187 variation AA, except interlead flash.



- NOTES:
- A. All linear dimensions are in millimeters.
  - B. This drawing is subject to change without notice.
  - C. Publication IPC-7351 is recommended for alternate designs.
  - D. Laser cutting apertures with trapezoidal walls and also rounding corners will offer better paste release. Customers should contact their board assembly site for stencil design recommendations. Refer to IPC-7525 for other stencil recommendations.
  - E. Customers should contact their board fabrication site for solder mask tolerances between and around signal pads.

DRB (S-PVSON-N8)

PLASTIC SMALL OUTLINE NO-LEAD

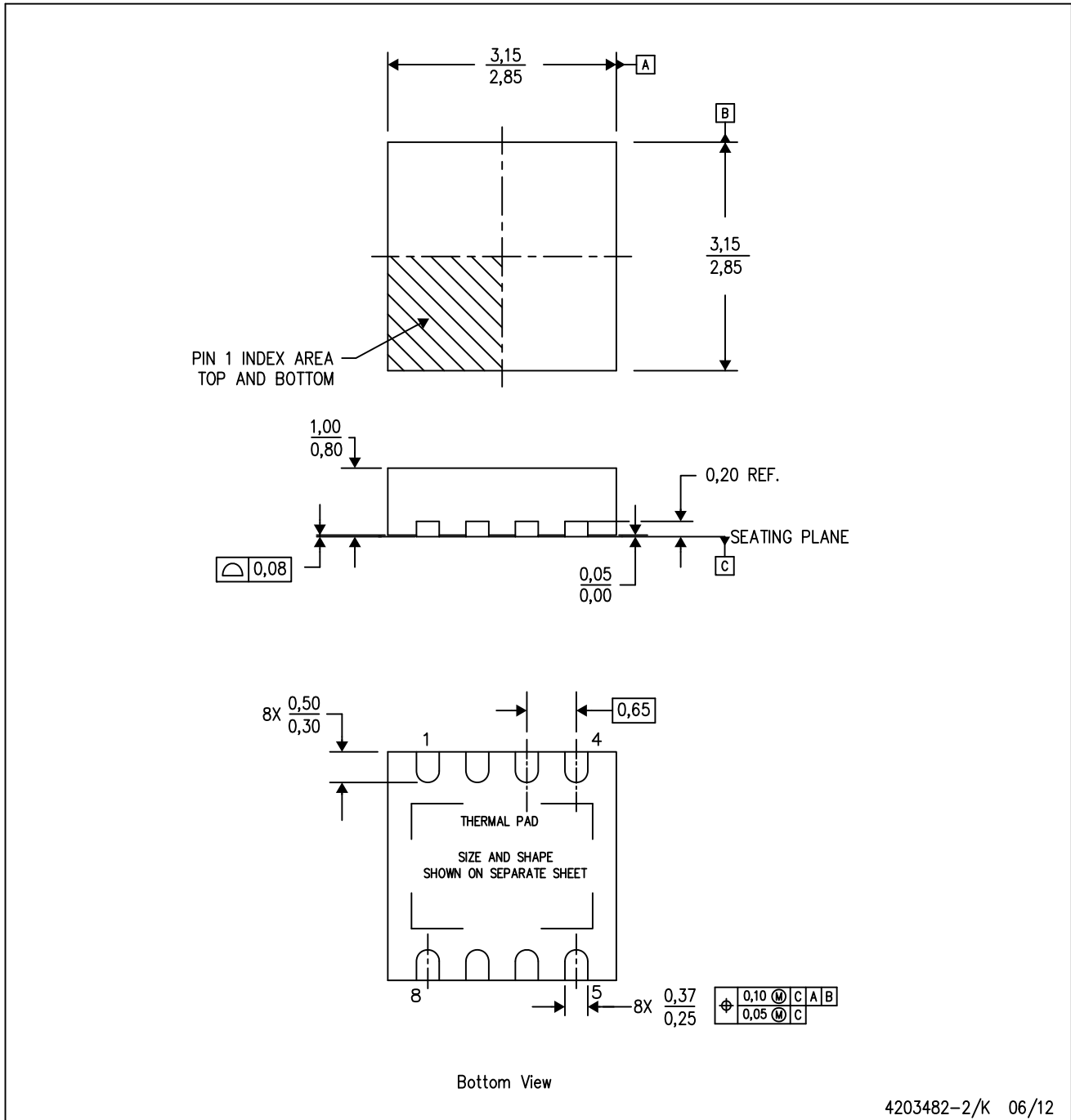

- NOTES:
- All linear dimensions are in millimeters. Dimensioning and tolerancing per ASME Y14.5M-1994.
  - This drawing is subject to change without notice.
  - Small Outline No-Lead (SON) package configuration.
  - The package thermal pad must be soldered to the board for thermal and mechanical performance.
  - See the additional figure in the Product Data Sheet for details regarding the exposed thermal pad features and dimensions.

THERMAL INFORMATION

This package incorporates an exposed thermal pad that is designed to be attached directly to an external heatsink. The thermal pad must be soldered directly to the printed circuit board (PCB). After soldering, the PCB can be used as a heatsink. In addition, through the use of thermal vias, the thermal pad can be attached directly to the appropriate copper plane shown in the electrical schematic for the device, or alternatively, can be attached to a special heatsink structure designed into the PCB. This design optimizes the heat transfer from the integrated circuit (IC).

For information on the Quad Flatpack No-Lead (QFN) package and its advantages, refer to Application Report, QFN/SON PCB Attachment, Texas Instruments Literature No. SLUA271. This document is available at [www.ti.com](http://www.ti.com).

The exposed thermal pad dimensions for this package are shown in the following illustration.

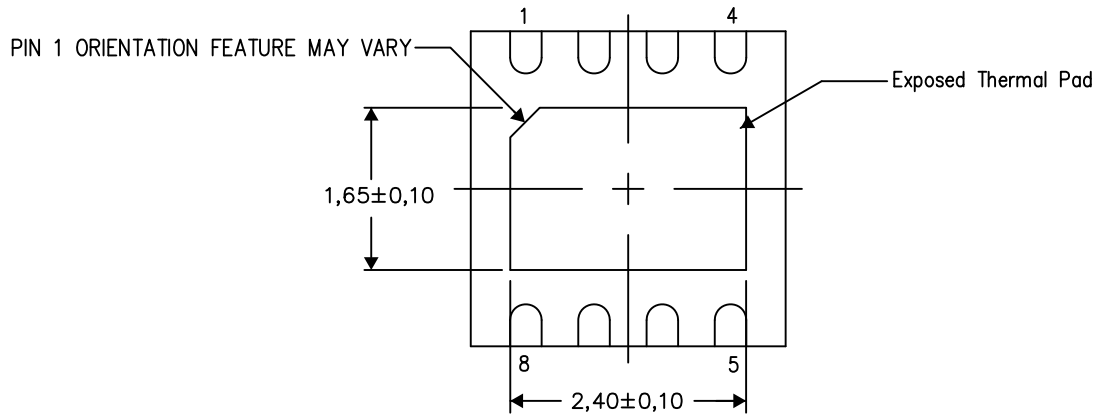

Bottom View

Exposed Thermal Pad Dimensions

4206340-3/T 08/15

NOTE: All linear dimensions are in millimeters

DRB (S-PVSON-N8)

PLASTIC SMALL OUTLINE NO-LEAD

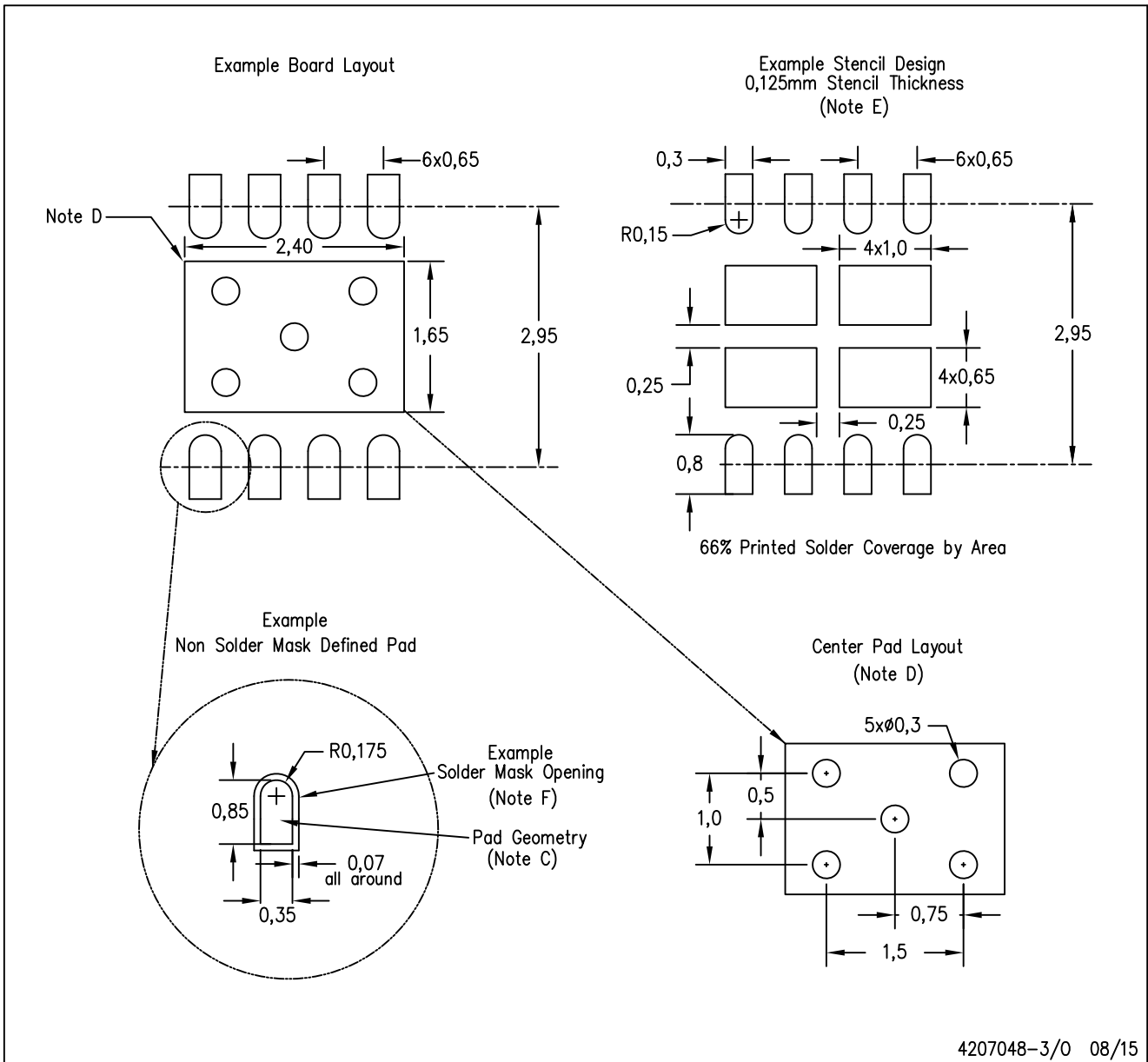

- NOTES:
- A. All linear dimensions are in millimeters.
  - B. This drawing is subject to change without notice.
  - C. Publication IPC-7351 is recommended for alternate designs.
  - D. This package is designed to be soldered to a thermal pad on the board. Refer to Application Note, QFN Packages, Texas Instruments Literature No. SLUA271, and also the Product Data Sheets for specific thermal information, via requirements, and recommended board layout. These documents are available at [www.ti.com](http://www.ti.com) <<http://www.ti.com>>.
  - E. Laser cutting apertures with trapezoidal walls and also rounding corners will offer better paste release. Customers should contact their board assembly site for stencil design recommendations. Refer to IPC 7525 for stencil design considerations.
  - F. Customers should contact their board fabrication site for solder mask tolerances.

PW (R-PDSO-G14)

PLASTIC SMALL OUTLINE

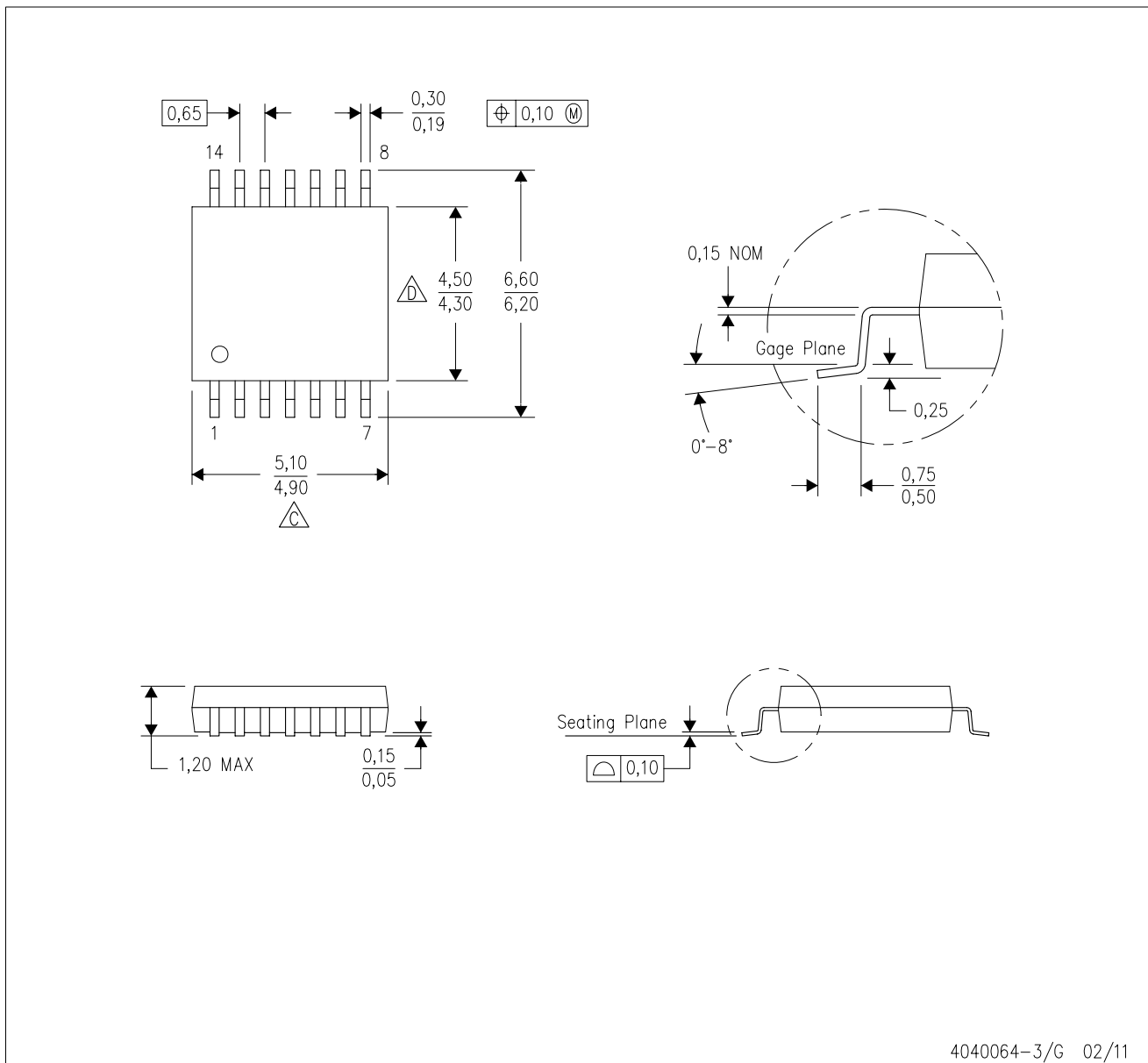

- NOTES:
- A. All linear dimensions are in millimeters. Dimensioning and tolerancing per ASME Y14.5M-1994.
  - B. This drawing is subject to change without notice.
  - C. Body length does not include mold flash, protrusions, or gate burrs. Mold flash, protrusions, or gate burrs shall not exceed 0,15 each side.
  - D. Body width does not include interlead flash. Interlead flash shall not exceed 0,25 each side.
  - E. Falls within JEDEC MO-153

PW (R-PDSO-G14)

PLASTIC SMALL OUTLINE



- NOTES:
- All linear dimensions are in millimeters.
  - This drawing is subject to change without notice.
  - Publication IPC-7351 is recommended for alternate designs.
  - Laser cutting apertures with trapezoidal walls and also rounding corners will offer better paste release. Customers should contact their board assembly site for stencil design recommendations. Refer to IPC-7525 for other stencil recommendations.
  - Customers should contact their board fabrication site for solder mask tolerances between and around signal pads.

RGY (S-PVQFN-N14)

PLASTIC QUAD FLATPACK NO-LEAD

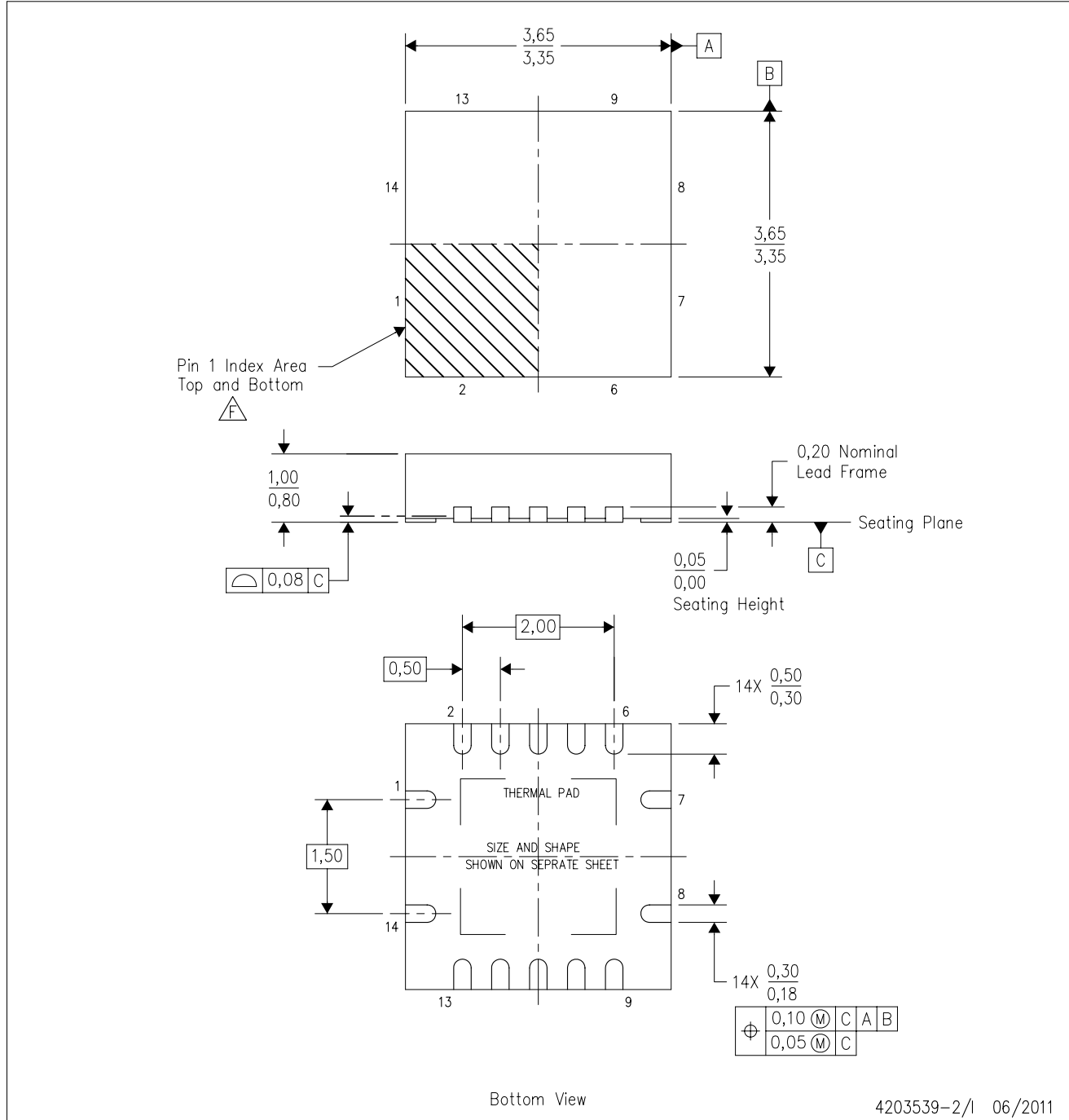

4203539-2/1 06/2011

- NOTES:
- All linear dimensions are in millimeters. Dimensioning and tolerancing per ASME Y14.5M-1994.
  - This drawing is subject to change without notice.
  - QFN (Quad Flatpack No-Lead) package configuration.
  - The package thermal pad must be soldered to the board for thermal and mechanical performance.
  - See the additional figure in the Product Data Sheet for details regarding the exposed thermal pad features and dimensions.
  - ⚠ Pin 1 identifiers are located on both top and bottom of the package and within the zone indicated. The Pin 1 identifiers are either a molded, marked, or metal feature.
  - Package complies to JEDEC MO-241 variation BA.

RGY (S-PVQFN-N14)

PLASTIC QUAD FLATPACK NO-LEAD

**THERMAL INFORMATION**

This package incorporates an exposed thermal pad that is designed to be attached directly to an external heatsink. The thermal pad must be soldered directly to the printed circuit board (PCB). After soldering, the PCB can be used as a heatsink. In addition, through the use of thermal vias, the thermal pad can be attached directly to the appropriate copper plane shown in the electrical schematic for the device, or alternatively, can be attached to a special heatsink structure designed into the PCB. This design optimizes the heat transfer from the integrated circuit (IC).

For information on the Quad Flatpack No-Lead (QFN) package and its advantages, refer to Application Report, QFN/SON PCB Attachment, Texas Instruments Literature No. SLUA271. This document is available at [www.ti.com](http://www.ti.com).

The exposed thermal pad dimensions for this package are shown in the following illustration.

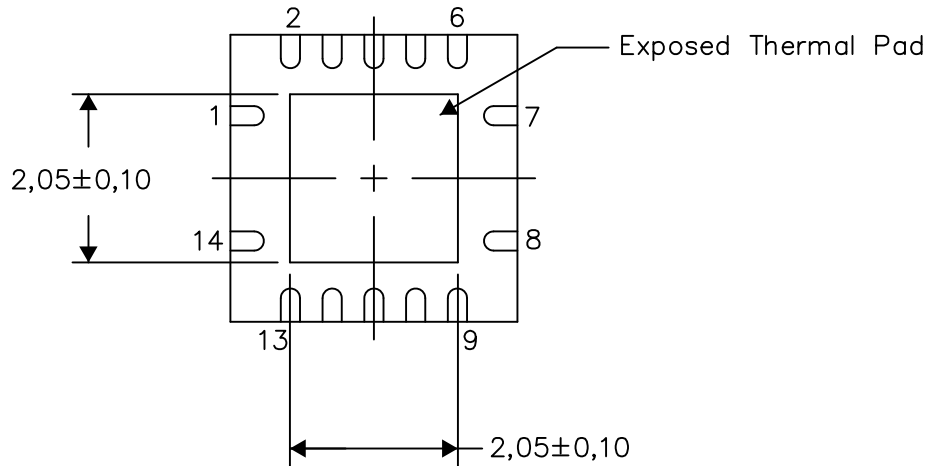

Bottom View

Exposed Thermal Pad Dimensions

4206353-2/P 03/14

NOTE: All linear dimensions are in millimeters

RGY (S-PVQFN-N14)

PLASTIC QUAD FLATPACK NO-LEAD

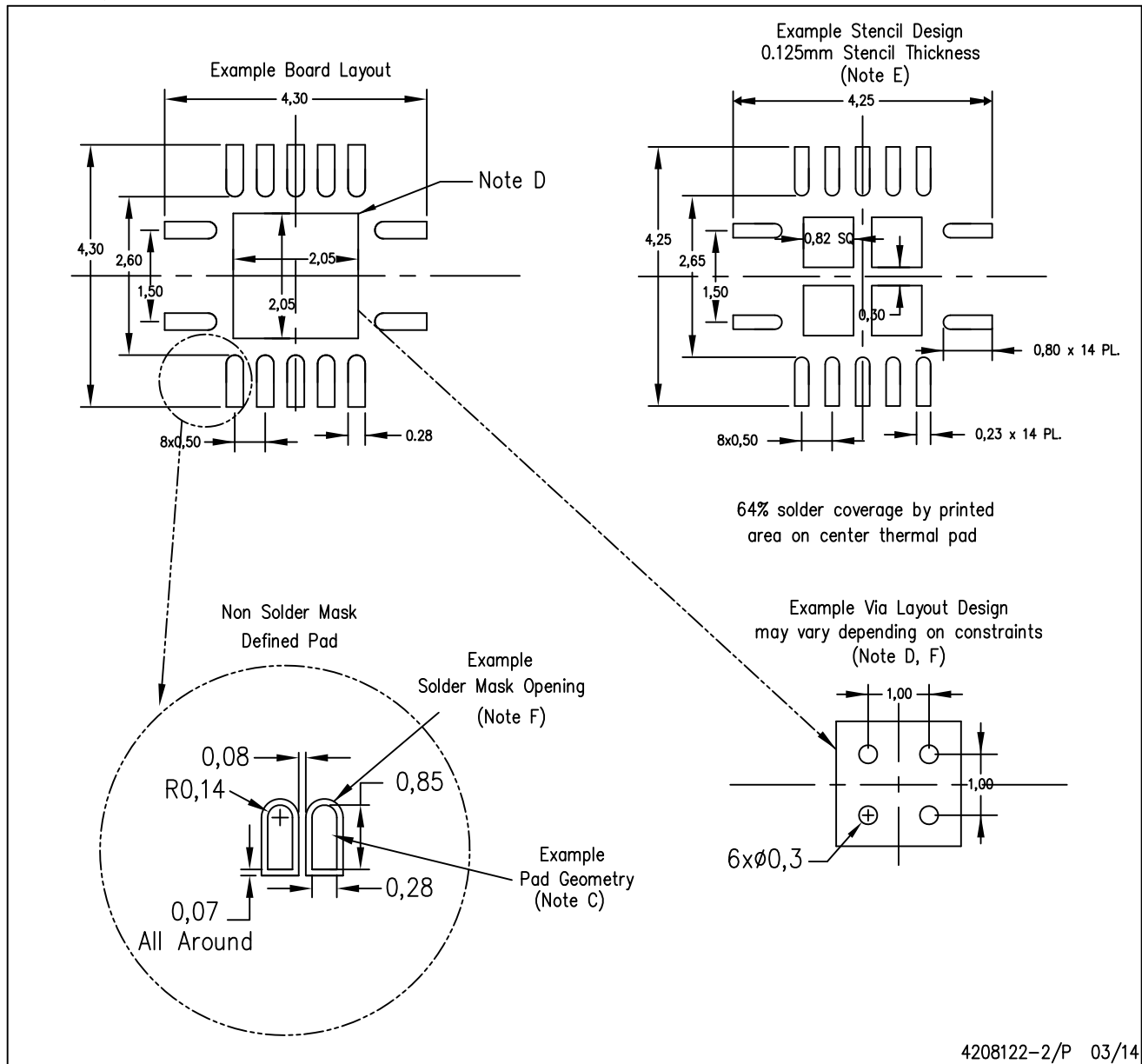

4208122-2/P 03/14

- NOTES:
- All linear dimensions are in millimeters.
  - This drawing is subject to change without notice.
  - Publication IPC-7351 is recommended for alternate designs.
  - This package is designed to be soldered to a thermal pad on the board. Refer to Application Note, Quad Flat-Pack QFN/SON PCB Attachment, Texas Instruments Literature No. SLUA271, and also the Product Data Sheets for specific thermal information, via requirements, and recommended board layout. These documents are available at [www.ti.com](http://www.ti.com) <<http://www.ti.com>>.
  - Laser cutting apertures with trapezoidal walls and also rounding corners will offer better paste release. Customers should contact their board assembly site for stencil design recommendations. Refer to IPC 7525 for stencil design considerations.
  - Customers should contact their board fabrication site for minimum solder mask web tolerances between signal pads.

D (R-PDSO-G8)

PLASTIC SMALL OUTLINE

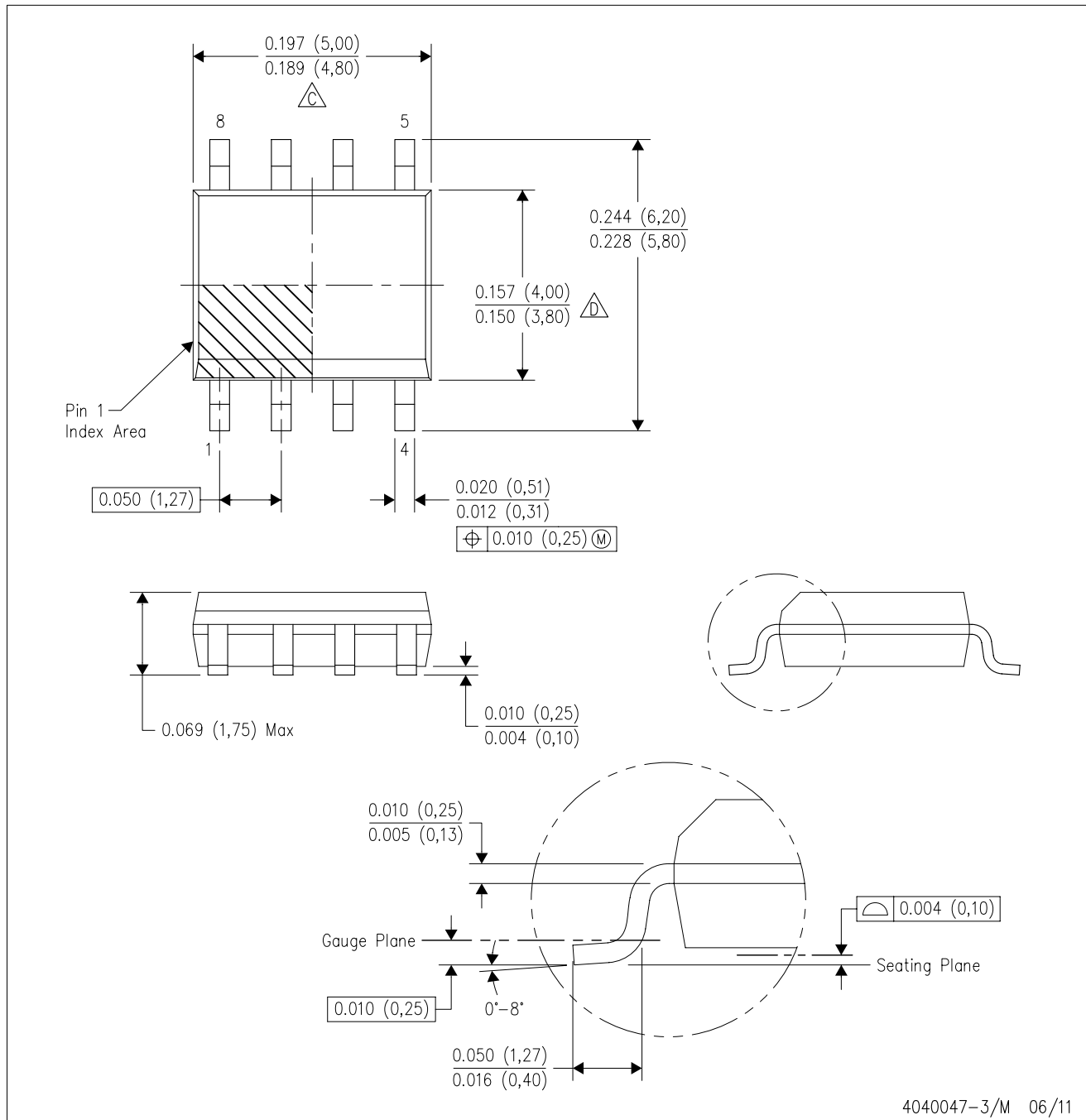

NOTES: A. All linear dimensions are in inches (millimeters).  
 B. This drawing is subject to change without notice.  
 C. Body length does not include mold flash, protrusions, or gate burrs. Mold flash, protrusions, or gate burrs shall not exceed 0.006 (0,15) each side.  
 D. Body width does not include interlead flash. Interlead flash shall not exceed 0.017 (0,43) each side.  
 E. Reference JEDEC MS-012 variation AA.

D (R-PDSO-G8)

PLASTIC SMALL OUTLINE

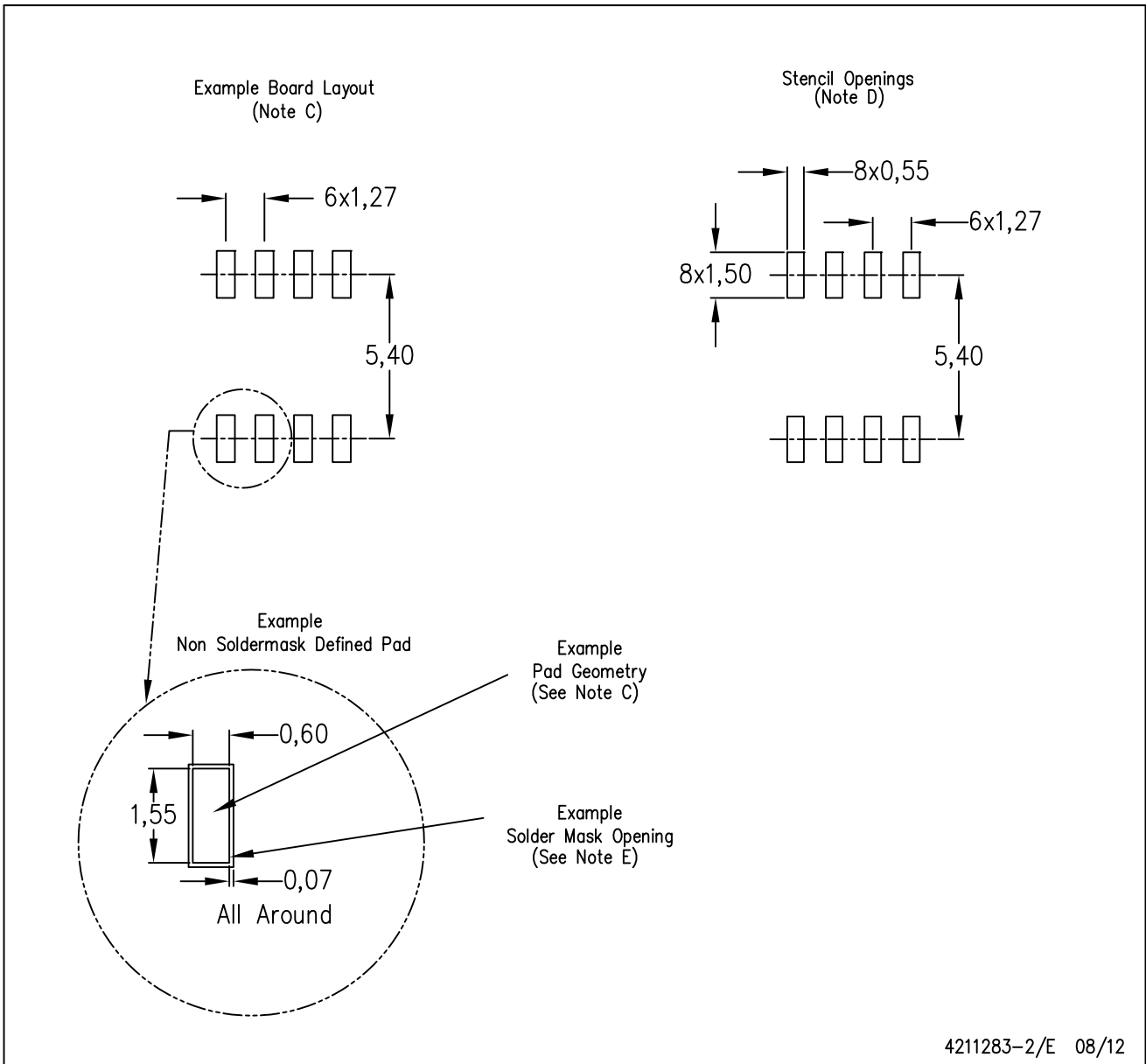

- NOTES:
- A. All linear dimensions are in millimeters.
  - B. This drawing is subject to change without notice.
  - C. Publication IPC-7351 is recommended for alternate designs.
  - D. Laser cutting apertures with trapezoidal walls and also rounding corners will offer better paste release. Customers should contact their board assembly site for stencil design recommendations. Refer to IPC-7525 for other stencil recommendations.
  - E. Customers should contact their board fabrication site for solder mask tolerances between and around signal pads.

# MECHANICAL DATA

YFF (S-XBGA-N5)

DIE-SIZE BALL GRID ARRAY

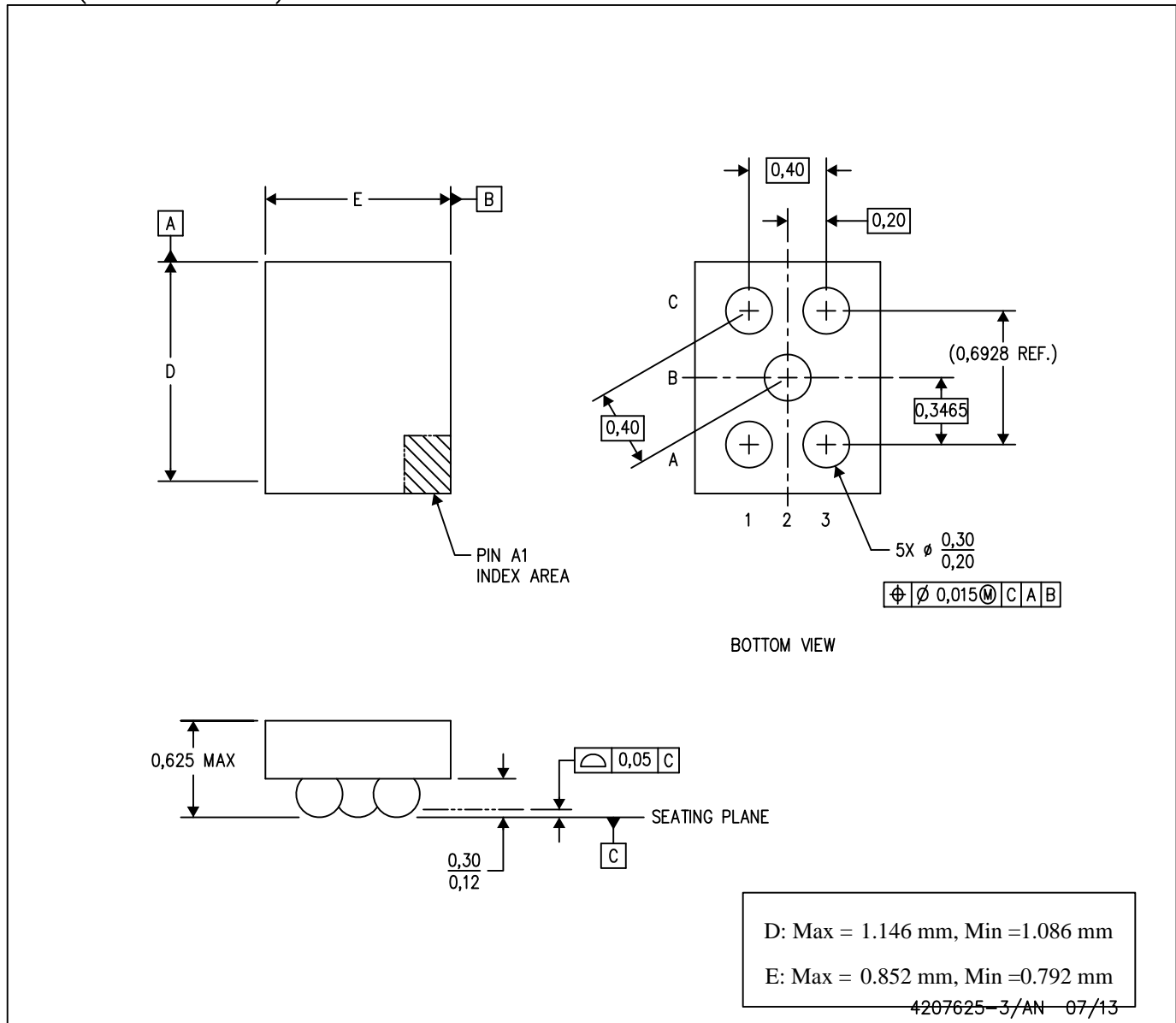

- NOTES: A. All linear dimensions are in millimeters. Dimensioning and tolerancing per ASME Y14.5M-1994.  
B. This drawing is subject to change without notice.  
C. NanoFree™ package configuration.

PowerPAD is a trademark of Texas Instruments.

## IMPORTANT NOTICE

Texas Instruments Incorporated and its subsidiaries (TI) reserve the right to make corrections, enhancements, improvements and other changes to its semiconductor products and services per JESD46, latest issue, and to discontinue any product or service per JESD48, latest issue. Buyers should obtain the latest relevant information before placing orders and should verify that such information is current and complete. All semiconductor products (also referred to herein as "components") are sold subject to TI's terms and conditions of sale supplied at the time of order acknowledgment.

TI warrants performance of its components to the specifications applicable at the time of sale, in accordance with the warranty in TI's terms and conditions of sale of semiconductor products. Testing and other quality control techniques are used to the extent TI deems necessary to support this warranty. Except where mandated by applicable law, testing of all parameters of each component is not necessarily performed.

TI assumes no liability for applications assistance or the design of Buyers' products. Buyers are responsible for their products and applications using TI components. To minimize the risks associated with Buyers' products and applications, Buyers should provide adequate design and operating safeguards.

TI does not warrant or represent that any license, either express or implied, is granted under any patent right, copyright, mask work right, or other intellectual property right relating to any combination, machine, or process in which TI components or services are used. Information published by TI regarding third-party products or services does not constitute a license to use such products or services or a warranty or endorsement thereof. Use of such information may require a license from a third party under the patents or other intellectual property of the third party, or a license from TI under the patents or other intellectual property of TI.

Reproduction of significant portions of TI information in TI data books or data sheets is permissible only if reproduction is without alteration and is accompanied by all associated warranties, conditions, limitations, and notices. TI is not responsible or liable for such altered documentation. Information of third parties may be subject to additional restrictions.

Resale of TI components or services with statements different from or beyond the parameters stated by TI for that component or service voids all express and any implied warranties for the associated TI component or service and is an unfair and deceptive business practice. TI is not responsible or liable for any such statements.

Buyer acknowledges and agrees that it is solely responsible for compliance with all legal, regulatory and safety-related requirements concerning its products, and any use of TI components in its applications, notwithstanding any applications-related information or support that may be provided by TI. Buyer represents and agrees that it has all the necessary expertise to create and implement safeguards which anticipate dangerous consequences of failures, monitor failures and their consequences, lessen the likelihood of failures that might cause harm and take appropriate remedial actions. Buyer will fully indemnify TI and its representatives against any damages arising out of the use of any TI components in safety-critical applications.

In some cases, TI components may be promoted specifically to facilitate safety-related applications. With such components, TI's goal is to help enable customers to design and create their own end-product solutions that meet applicable functional safety standards and requirements. Nonetheless, such components are subject to these terms.

No TI components are authorized for use in FDA Class III (or similar life-critical medical equipment) unless authorized officers of the parties have executed a special agreement specifically governing such use.

Only those TI components which TI has specifically designated as military grade or "enhanced plastic" are designed and intended for use in military/aerospace applications or environments. Buyer acknowledges and agrees that any military or aerospace use of TI components which have **not** been so designated is solely at the Buyer's risk, and that Buyer is solely responsible for compliance with all legal and regulatory requirements in connection with such use.

TI has specifically designated certain components as meeting ISO/TS16949 requirements, mainly for automotive use. In any case of use of non-designated products, TI will not be responsible for any failure to meet ISO/TS16949.

### Products

Audio	<a href="http://www.ti.com/audio">www.ti.com/audio</a>
Amplifiers	<a href="http://amplifier.ti.com">amplifier.ti.com</a>
Data Converters	<a href="http://dataconverter.ti.com">dataconverter.ti.com</a>
DLP® Products	<a href="http://www.dlp.com">www.dlp.com</a>
DSP	<a href="http://dsp.ti.com">dsp.ti.com</a>
Clocks and Timers	<a href="http://www.ti.com/clocks">www.ti.com/clocks</a>
Interface	<a href="http://interface.ti.com">interface.ti.com</a>
Logic	<a href="http://logic.ti.com">logic.ti.com</a>
Power Mgmt	<a href="http://power.ti.com">power.ti.com</a>
Microcontrollers	<a href="http://microcontroller.ti.com">microcontroller.ti.com</a>
RFID	<a href="http://www.ti-rfid.com">www.ti-rfid.com</a>
OMAP Applications Processors	<a href="http://www.ti.com/omap">www.ti.com/omap</a>
Wireless Connectivity	<a href="http://www.ti.com/wirelessconnectivity">www.ti.com/wirelessconnectivity</a>

### Applications

Automotive and Transportation	<a href="http://www.ti.com/automotive">www.ti.com/automotive</a>
Communications and Telecom	<a href="http://www.ti.com/communications">www.ti.com/communications</a>
Computers and Peripherals	<a href="http://www.ti.com/computers">www.ti.com/computers</a>
Consumer Electronics	<a href="http://www.ti.com/consumer-apps">www.ti.com/consumer-apps</a>
Energy and Lighting	<a href="http://www.ti.com/energy">www.ti.com/energy</a>
Industrial	<a href="http://www.ti.com/industrial">www.ti.com/industrial</a>
Medical	<a href="http://www.ti.com/medical">www.ti.com/medical</a>
Security	<a href="http://www.ti.com/security">www.ti.com/security</a>
Space, Avionics and Defense	<a href="http://www.ti.com/space-avionics-defense">www.ti.com/space-avionics-defense</a>
Video and Imaging	<a href="http://www.ti.com/video">www.ti.com/video</a>

### TI E2E Community

[e2e.ti.com](http://e2e.ti.com)