

OPAx348-Q1 1-MHz 45- μ A CMOS Rail-to-Rail Operational Amplifier

1 Features

- Qualified for Automotive Applications
- AEC-Q100 Qualified With the Following Results:
 - Device Temperature Grade 1: -40°C to 125°C Ambient Operating Temperature Range
 - Device HBM ESD Classification Level 2
 - Device CDM ESD Classification Level C4B
- Low Quiescent Current (I_Q): 45 μA (Typ)
- Low Cost
- Rail-to-Rail Input and Output
- Single Supply: 2.1 V to 5.5 V
- Input Bias Current: 0.5 pA (Typ)
- High Speed: Power With Bandwidth: 1 MHz

2 Applications

- Portable Equipment
- Battery-Powered Equipment
- Smoke Alarms
- CO Detectors
- HEV/EV and Power Train
- Infotainment and Cluster
- Medical Instrumentation

3 Description

The OPAx348-Q1 series of device are single-supply low-power CMOS operational amplifiers. Featuring an extended bandwidth of 1 MHz and a supply current of 45 μA , the OPAx348-Q1 family of devices is useful for low-power applications on single supplies of 2.1 V to 5.5 V.

Low supply current of 45 μA and an input bias current of 0.5 pA make the OPAx348-Q1 family of devices an optimal candidate for low-power high-impedance applications such as smoke detectors and other sensors.

The OPA348-Q1 device is available in the SOT23-5 (DBV) package. The OPA2348-Q1 device is available in the SOIC-8 (D) package. The OPA4348-Q1 device is available in the TSSOP-14 (PW) package. The automotive temperature range of -40°C to 125°C over all supply voltages offers additional design flexibility.

Device Information⁽¹⁾

PART NUMBER	PACKAGE	BODY SIZE (NOM)
OPA348-Q1	SOT-23 (5)	2.90 mm x 1.60 mm
OPA2348-Q1	SOIC (8)	4.90 mm x 3.91 mm
OPA4348-Q1	TSSOP (14)	5.00 mm x 4.40 mm

(1) For all available packages, see the orderable addendum at the end of the datasheet.

Noninverting Configuration Driving ADS7822

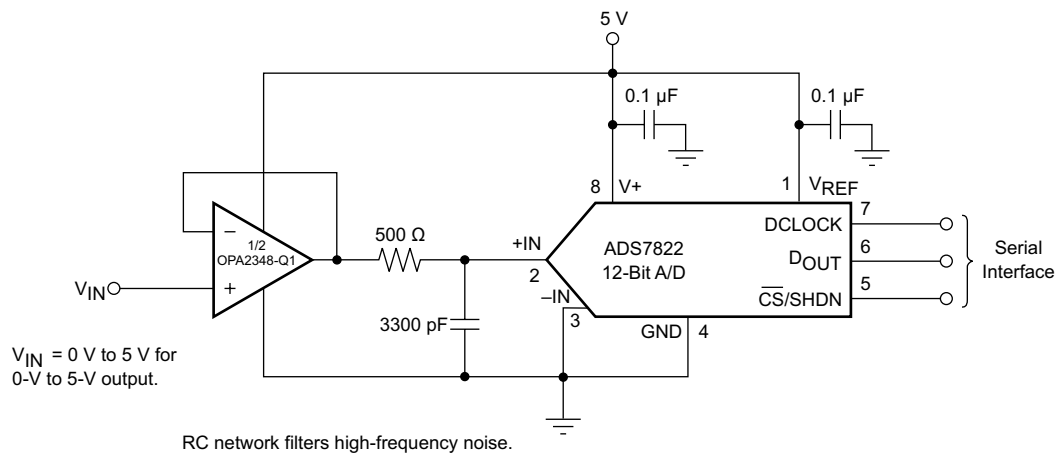

Table of Contents

1 Features	1	7.4 Device Functional Modes.....	13
2 Applications	1	8 Application and Implementation	14
3 Description	1	8.1 Application Information.....	14
4 Revision History	2	8.2 Typical Application	15
5 Pin Configuration and Functions	3	9 Power Supply Recommendations	17
6 Specifications	4	10 Layout	18
6.1 Absolute Maximum Ratings	4	10.1 Layout Guidelines	18
6.2 ESD Ratings.....	4	10.2 Layout Example	18
6.3 Recommended Operating Conditions.....	4	11 Device and Documentation Support	19
6.4 Thermal Information	4	11.1 Documentation Support	19
6.5 Electrical Characteristics.....	5	11.2 Related Links	19
6.6 Typical Characteristics.....	6	11.3 Trademarks	19
7 Detailed Description	9	11.4 Electrostatic Discharge Caution.....	19
7.1 Overview	9	11.5 Glossary	19
7.2 Functional Block Diagram	9	12 Mechanical, Packaging, and Orderable	
7.3 Feature Description.....	10	Information	19

4 Revision History

Changes from Revision A (January 2009) to Revision B	Page
• Added two new applications to the <i>Applications</i> section	1
• Added the <i>ESD Ratings</i> table, <i>Feature Description</i> section, <i>Device Functional Modes</i> section, <i>Application and Implementation</i> section, <i>Power Supply Recommendations</i> section, <i>Layout</i> section, <i>Device and Documentation Support</i> section, and <i>Mechanical, Packaging, and Orderable Information</i> section	1
• Added the OPA348-Q1 device to the data sheet	1
• Changed the name for pin 3 in the PW (TSSOP) Package drawing.....	3

5 Pin Configuration and Functions

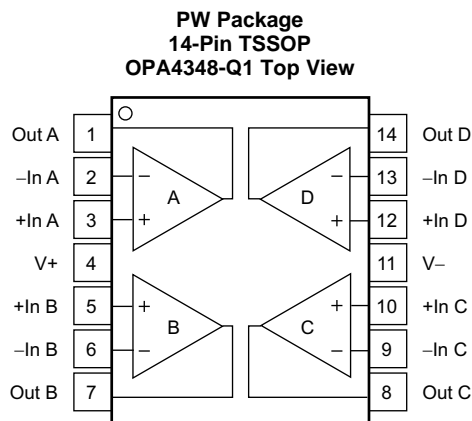
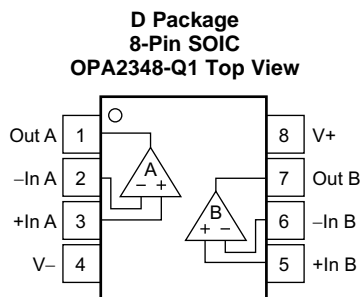
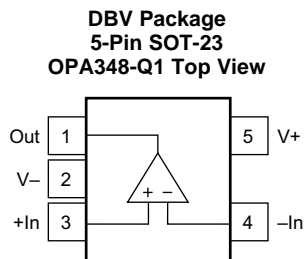

Pin Functions

NAME	PIN			I/O	DESCRIPTION
	OPA348-Q1 DBV	OPA2348-Q1 DGK	OPA4348-Q1 PW		
+IN	3	—	—	I	Noninverting input
-IN	4	—	—	I	Inverting input
+IN A	—	3	3	I	Noninverting input, Channel A
-IN A	—	2	2	I	Inverting input, Channel A
+IN B	—	5	5	I	Noninverting input, Channel B
-IN B	—	6	6	I	Inverting input, Channel B
+IN C	—	—	10	I	Noninverting input, Channel C
-IN C	—	—	9	I	Inverting input, Channel C
+IN D	—	—	12	I	Noninverting input, Channel D
-IN D	—	—	13	I	Inverting input, Channel D
OUT	1	—	—	O	Output
OUT A	—	1	1	O	Output, Channel A
OUT B	—	7	7	O	Output, Channel B
OUT C	—	—	8	O	Output, Channel C
OUT D	—	—	14	O	Output, Channel D
V+	5	8	4	—	Positive (highest) supply
V-	2	4	11	—	Negative (lowest) supply

6 Specifications

6.1 Absolute Maximum Ratings

over operating free-air temperature range (unless otherwise noted)⁽¹⁾

		MIN	MAX	UNIT
Supply voltage, V_S	V– to V+		7.5	V
Input voltage, V_{IN}	Signal input terminals ⁽²⁾	(V–) – 0.5 V	(V+) + 0.5 V	V
Input current, I_{IN}	Signal input terminals ⁽²⁾		10	mA
Output short-circuit duration ⁽³⁾		Continuous		
Operating free-air temperature, T_A		–40	150	°C
Operating virtual-junction temperature, T_J			150	°C
Storage temperature, T_{sig}		–65	150	°C

- (1) Stresses beyond those listed under *absolute maximum ratings* may cause permanent damage to the device. These are stress ratings only, and functional operation of the device at these or any other conditions beyond those indicated under *recommended operating conditions* is not implied. Exposure to absolute-maximum-rated conditions for extended periods may affect device reliability.
- (2) Input terminals are diode-clamped to the power-supply rails. Input signals that can swing more than 0.5 V beyond the supply rails should be current-limited to 10 mA or less.
- (3) Short-circuit to ground, one amplifier per package.

6.2 ESD Ratings

		VALUE	UNIT	
$V_{(ESD)}$ Electrostatic discharge	Human-body model (HBM), per AEC Q100-002 ⁽¹⁾	±2000	V	
	Charged-device model (CDM), per AEC Q100-011	All pins		±500
		Corner pins (1, 7, 8, 14)		±750

- (1) AEC Q100-002 indicates that HBM stressing shall be in accordance with the ANSI/ESDA/JEDEC JS-001 specification.

6.3 Recommended Operating Conditions

over operating free-air temperature range (unless otherwise noted)

		MIN	MAX	UNIT
V_S	Supply voltage, V– to V+	2.1	5.5	V
T_A	Operating free-air temperature	–40	125	°C

6.4 Thermal Information

THERMAL METRIC ⁽¹⁾		OPA348-Q1	OPA2348-Q1	OPA4348-Q1	UNIT
		DBV (SOT-23)	D (SOIC)	PW (TSSOP)	
		5 PINS	8 PINS	14 PINS	
$R_{\theta JA}$	Junction-to-ambient thermal resistance	228.5	138.4	121	°C/W
$R_{\theta JC(top)}$	Junction-to-case (top) thermal resistance	99.1	89.5	49.4	
$R_{\theta JB}$	Junction-to-board thermal resistance	54.6	78.6	62.8	
ψ_{JT}	Junction-to-top characterization parameter	7.7	29.9	5.9	
ψ_{JB}	Junction-to-board characterization parameter	53.8	78.1	62.2	

- (1) For more information about traditional and new thermal metrics, see the *IC Package Thermal Metrics* application report, [SPRA953](http://www.ti.com/lit/zip/Spra953).

6.5 Electrical Characteristics

 $V_S = 2.5\text{ V to }5.5\text{ V}$, $R_L = 100\text{ k}\Omega$ connected to $V_S / 2$, $V_{OUT} = V_S / 2$ (unless otherwise noted)

PARAMETER		TEST CONDITIONS	T_A ⁽¹⁾	MIN	TYP	MAX	UNIT
V_{OS}	Input offset voltage	$V_S = 5\text{ V}$, $V_{CM} = (V-) + 0.8\text{ V}$	25°C		1	5	mV
			Full range			6	
$\Delta V_{OS}/\Delta T$	Offset voltage drift over temperature		Full range		4		$\mu\text{V}/^\circ\text{C}$
PSRR	Offset voltage drift vs power supply	$V_S = 2.5\text{ V to }5.5\text{ V}$, $V_{CM} < (V+) - 1.7\text{ V}$	25°C		60	175	$\mu\text{V}/\text{V}$
			Full range			300	
	Channel separation	dc	25°C		0.2		$\mu\text{V}/\text{V}$
			25°C		134		dB
V_{CM}	Input common-mode voltage range		25°C	$(V-) - 0.2$		$(V+) + 0.2$	V
CMRR	Input common-mode rejection ratio	$(V-) - 0.2\text{ V} < V_{CM} < (V+) - 1.7\text{ V}$	25°C	70	82		dB
			Full range	66			
		$V_S = 5.5\text{ V}$, $(V-) - 0.2\text{ V} < V_{CM} < (V+) + 0.2\text{ V}$	25°C	60	71		
			Full range	56			
I_B	Input bias current		25°C		± 0.5	± 10	pA
I_{OS}	Input offset current		25°C		± 0.5	± 10	pA
Z_I	Input impedance	Differential	25°C	$10^{13} 3$			$\Omega \mu\text{F}$
		Common-mode		$10^{13} 3$			
	Input voltage noise	$V_{CM} < (V+) - 1.7\text{ V}$, $f = 0.1\text{ Hz to }10\text{ Hz}$	25°C		10		μV_{PP}
V_n	Input voltage noise density	$V_{CM} < (V+) - 1.7\text{ V}$, $f = 1\text{ kHz}$	25°C		35		$\text{nV}/\sqrt{\text{Hz}}$
I_n	Input current noise density	$V_{CM} < (V+) - 1.7\text{ V}$, $f = 1\text{ kHz}$	25°C		4		$\text{fA}/\sqrt{\text{Hz}}$
A_{OL}	Open-loop voltage gain	$V_S = 5\text{ V}$, $R_L = 100\text{ k}\Omega$, $0.025\text{ V} < V_O < 4.975\text{ V}$	25°C	94	108		dB
			Full range	90			
		$V_S = 5\text{ V}$, $R_L = 5\text{ k}\Omega$, $0.125\text{ V} < V_O < 4.875\text{ V}$	25°C	90	98		
			Full range	88			
	Voltage output swing from rail	$R_L = 100\text{ k}\Omega$, $A_{OL} > 94\text{ dB}$	25°C		18	25	mV
			Full range			25	
		$R_L = 5\text{ k}\Omega$, $A_{OL} > 90\text{ dB}$	25°C		100	125	mV
			Full range			125	
I_{SC}	Output short-circuit current		25°C		± 10		mA
C_{LOAD}	Capacitive load drive	See the Typical Characteristics section	25°C				
GBW	Gain-bandwidth product	$C_L = 100\text{ pF}$	25°C		1		MHz
SR	Slew rate	$C_L = 100\text{ pF}$, $G = +1$	25°C		0.5		$\text{V}/\mu\text{s}$
t_s	Settling time	$C_L = 100\text{ pF}$, $V_S = 5.5\text{ V}$, 2V- step , $G = +1$	25°C	0.1%		5	μs
				0.01%		7	
	Overload recovery time	$V_{IN} \times \text{Gain} > V_S$	25°C		1.6		μs
THD+N	Total harmonic distortion plus noise	$C_L = 100\text{ pF}$, $V_S = 5.5\text{ V}$, $V_O = 3\text{ V}_{PP}$, $G = +1$, $f = 1\text{ kHz}$	25°C		0.0023	%	
I_Q	Quiescent current	Per amplifier	25°C		45	65	μA
			Full range			75	

(1) Full range $T_A = -40^\circ\text{C to }125^\circ\text{C}$.

6.6 Typical Characteristics

$T_A = 25^\circ\text{C}$, $R_L = 100\text{ k}\Omega$ connected to $V_S/2$, $V_{OUT} = V_S/2$ (unless otherwise noted)

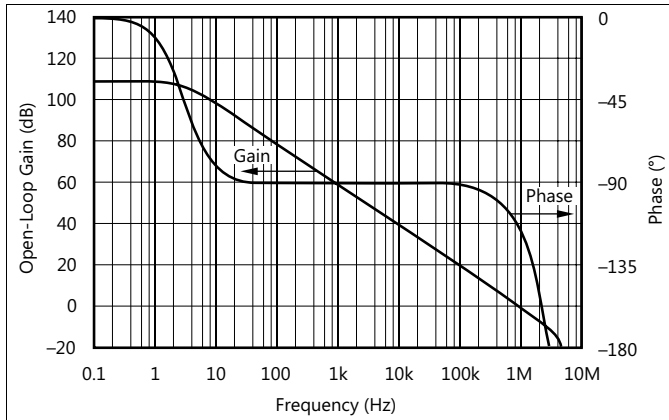

Figure 1. Open-Loop Gain and Phase vs Frequency

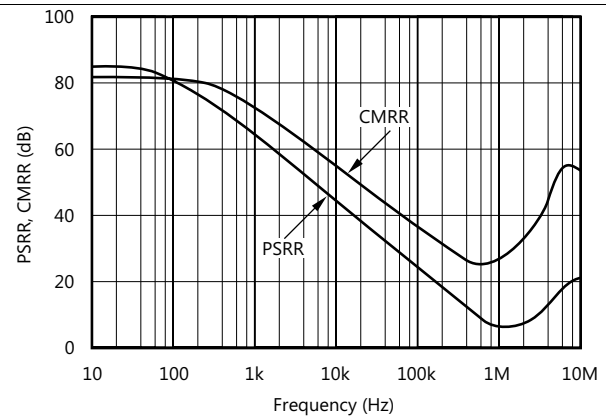

Figure 2. PSRR and CMRR vs Frequency

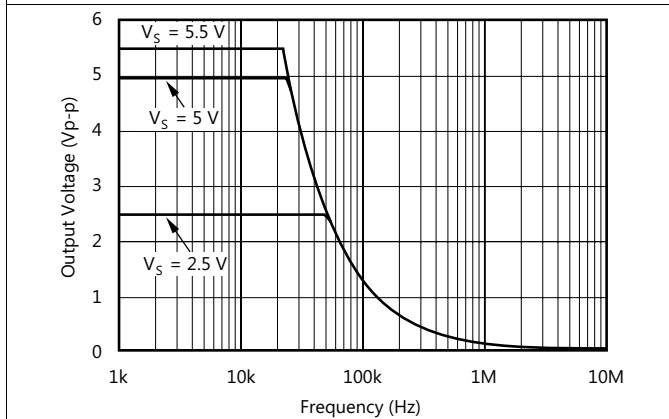

Figure 3. Maximum Output Voltage vs Frequency

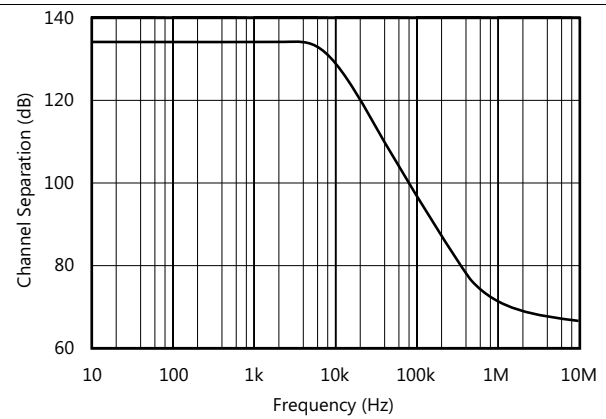

Figure 4. Channel Separation vs Frequency

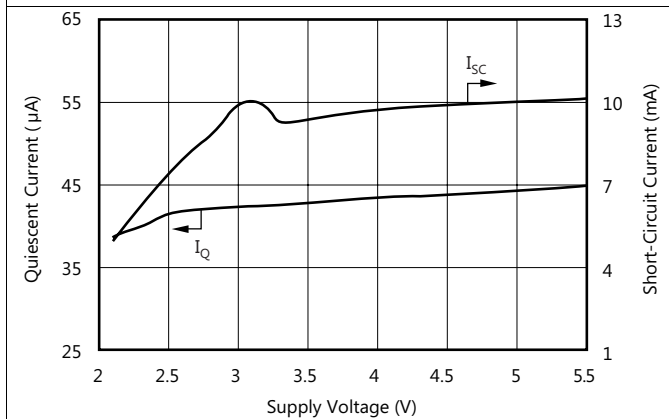

Figure 5. Quiescent and Short-Circuit Current vs Supply Voltage

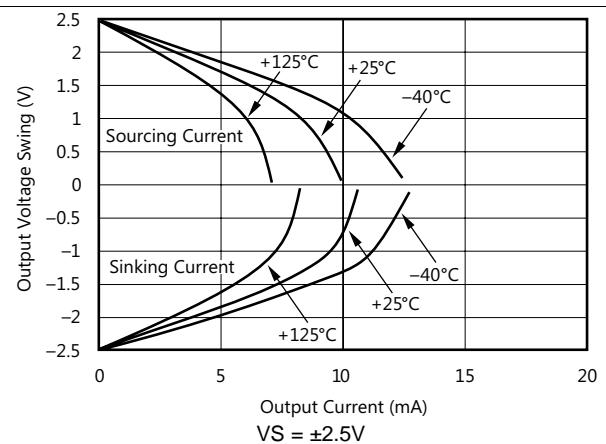

Figure 6. Output Voltage Swing vs Output Current
 $V_S = \pm 2.5\text{V}$

Typical Characteristics (continued)

$T_A = 25^\circ\text{C}$, $R_L = 100\text{ k}\Omega$ connected to $V_S/2$, $V_{OUT} = V_S/2$ (unless otherwise noted)

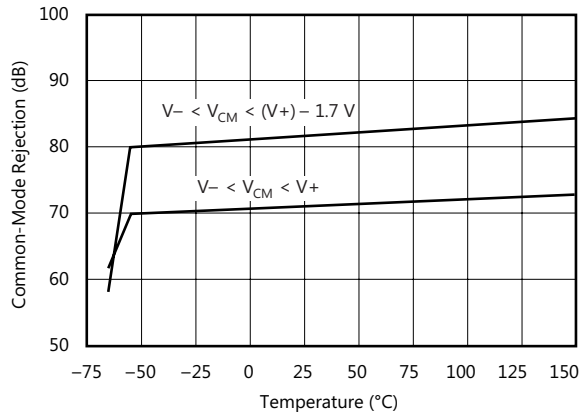

Figure 7. Common-Mode Rejection vs Temperature

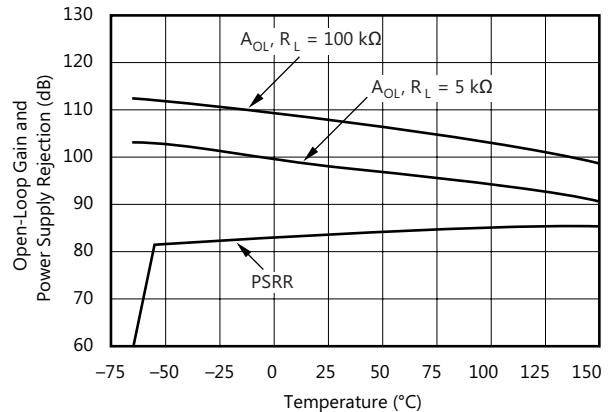

Figure 8. Open-Loop Gain and PSRR vs Temperature

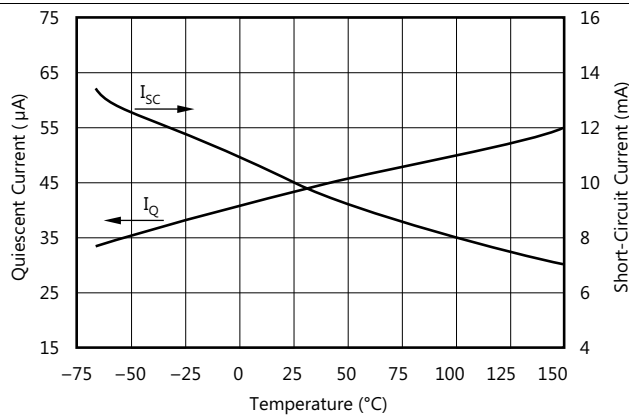

Figure 9. Quiescent and Short-Circuit Current vs Temperature

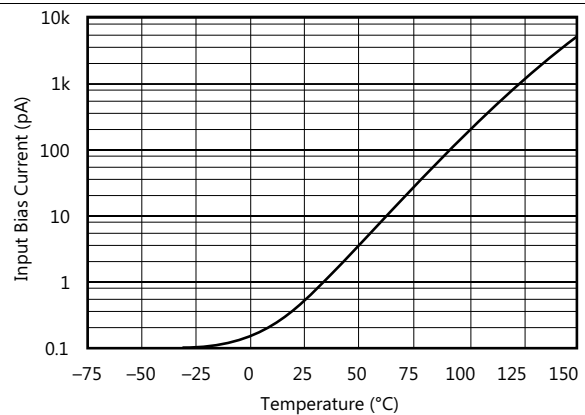
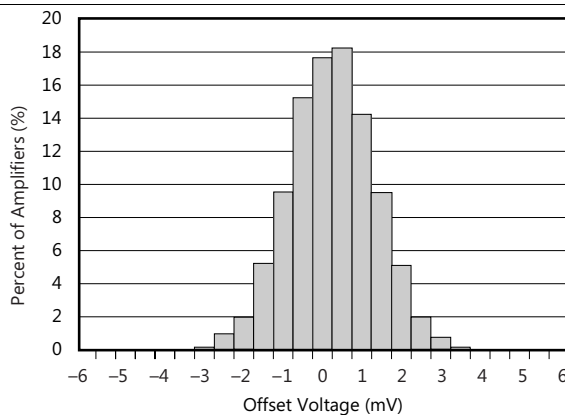
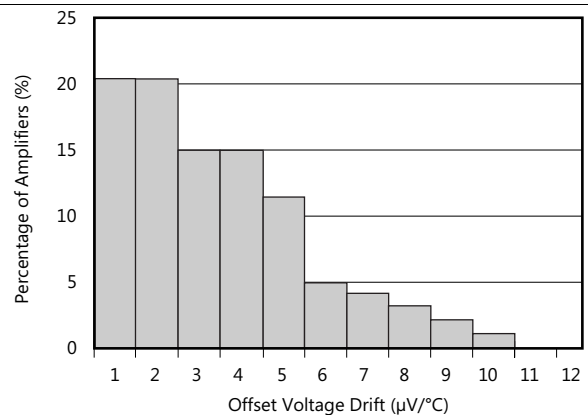

Figure 10. Input Bias (I_B) Current vs Temperature



Typical production distribution of packaged units.

Figure 11. Offset Voltage Production Distribution



Typical production distribution of packaged units.

Figure 12. Offset Voltage Drift Magnitude Production Distribution

Typical Characteristics (continued)

$T_A = 25^\circ\text{C}$, $R_L = 100\text{ k}\Omega$ connected to $V_S/2$, $V_{OUT} = V_S/2$ (unless otherwise noted)

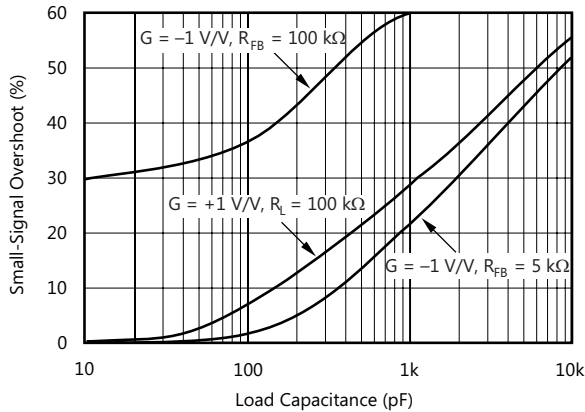

Figure 13. Small-Signal Overshoot vs Load Capacitance

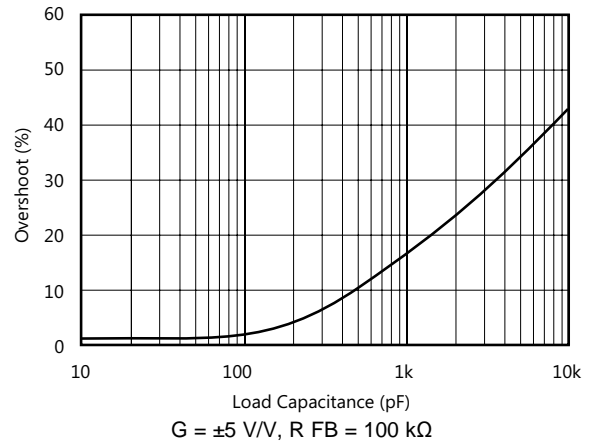

Figure 14. Percent Overshoot vs Load Capacitance

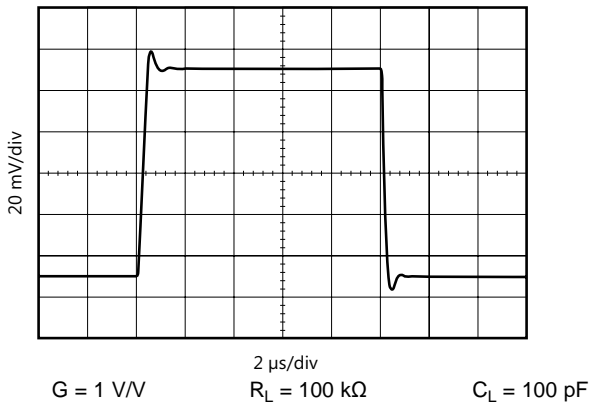

Figure 15. Small-Signal Step Response

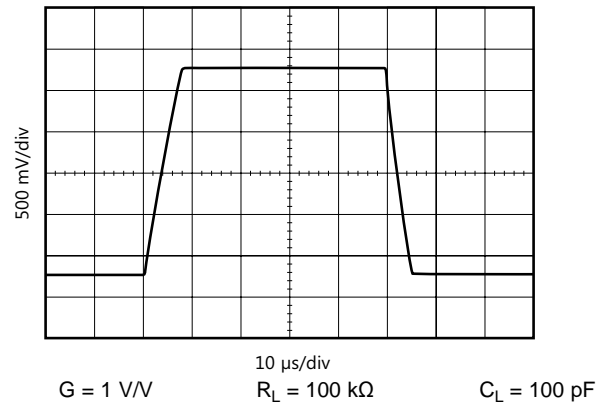

Figure 16. Large-Signal Step Response

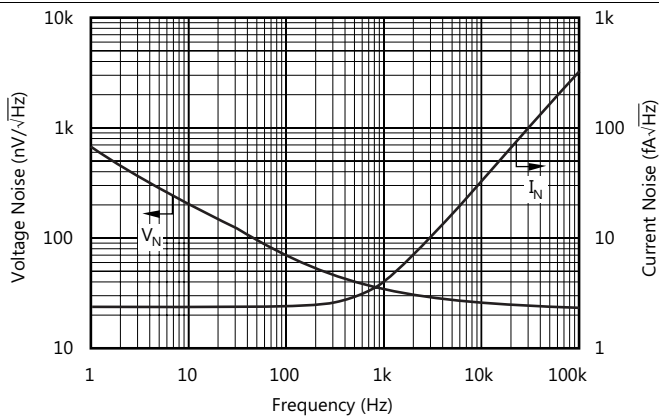

Figure 17. Input Current and Voltage Noise Spectral Density vs Frequency

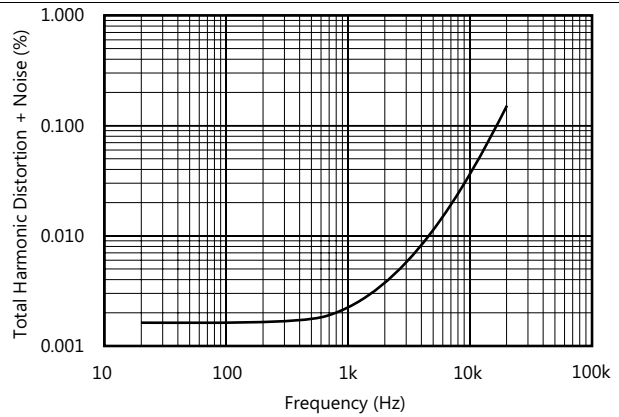

Figure 18. Total Harmonic Distortion + Noise v Frequency

7 Detailed Description

7.1 Overview

The OPAx348-Q1 family of devices is a low-power, rail-to-rail input and output operational amplifier. These devices operate from 1.8 V to 5.5 V, are unity-gain stable, and are suitable for a wide range of general-purpose applications. The class AB output stage is capable of driving $\leq 10\text{-k}\Omega$ loads connected to any point between $V+$ and ground. The input common-mode voltage range includes both rails and allows the OPAx348-Q1 family of devices to be used in virtually any single-supply application. Rail-to-rail input and output swing significantly increases dynamic range, especially in low-supply applications, and makes them ideal for driving sampling analog-to-digital converters (ADCs).

7.2 Functional Block Diagram

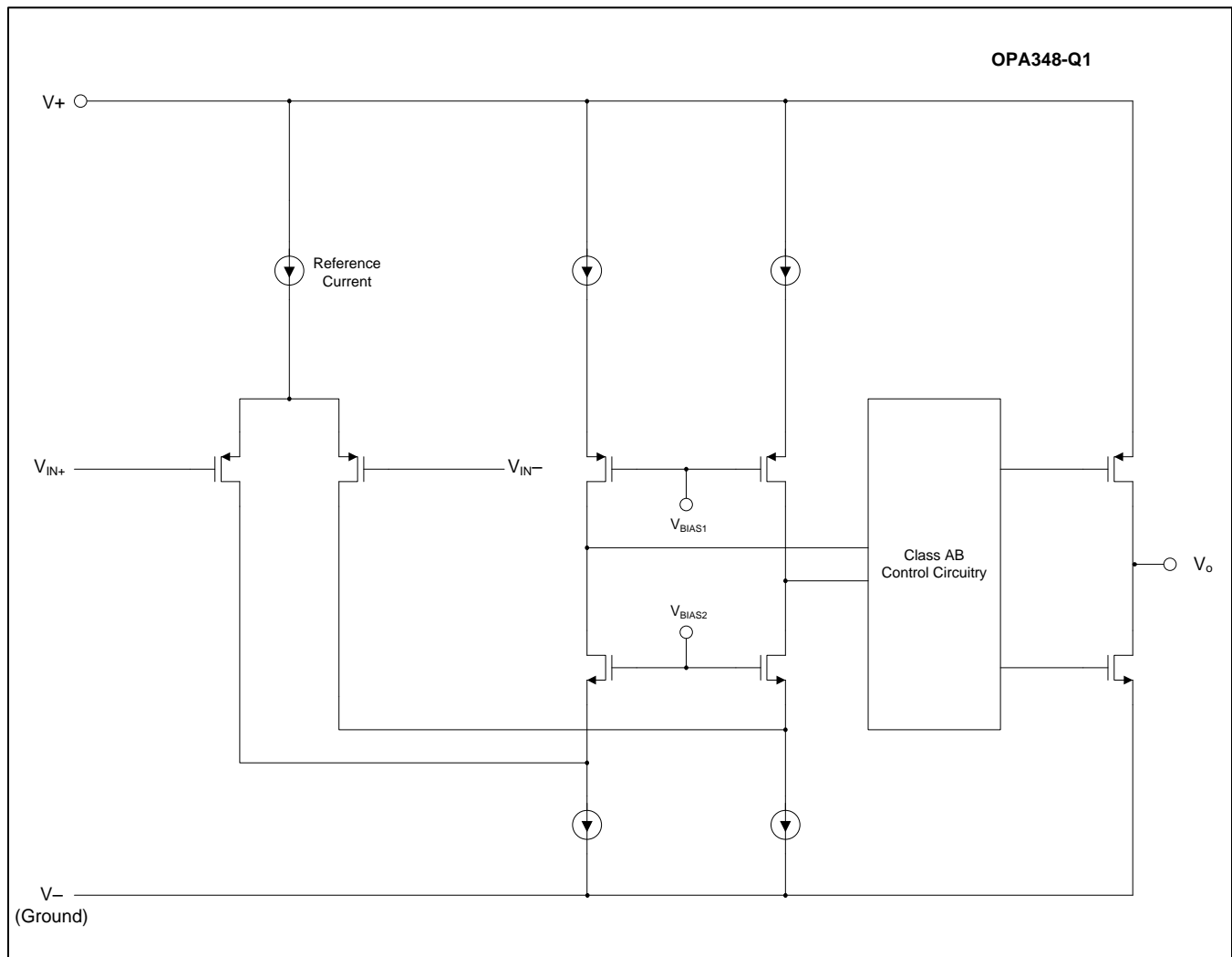

7.3 Feature Description

7.3.1 Operating Voltage

The OPAx348-Q1 op-amp is fully specified and ensured for operation from 1.8 V to 5.5 V. In addition, many specifications apply from -40°C to 125°C . Parameters that vary significantly with operating voltages or temperature are shown in the *Typical Characteristics* graphs. Power-supply pins should be bypassed with 0.01- μF ceramic capacitors.

7.3.2 Rail-to-Rail Input

The input common-mode voltage range of the OPAx348-Q1 family of devices extends 200 mV beyond the supply rails. This performance is achieved with a complementary input stage: an N-channel input differential pair in parallel with a P-channel differential pair. The N-channel pair is active for input voltages close to the positive rail, typically $(V+) - 1.3\text{ V}$ to 200 mV above the positive supply. The P-channel pair is on for inputs from 200 mV below the negative supply to approximately $(V+) - 1.3\text{ V}$. A small transition region exists, typically $(V+) - 1.4\text{ V}$ to $(V+) - 1.2\text{ V}$, in which both pairs are on. This 200-mV transition region can vary up to 300 mV with process variation. Thus, the transition region (both stages on) can range from $(V+) - 1.7\text{ V}$ to $(V+) - 1.5\text{ V}$ on the low end, up to $(V+) - 1.1\text{ V}$ to $(V+) - 0.9\text{ V}$ on the high end. Within this transition region, PSRR, CMRR, offset voltage, offset drift, and THD may be degraded compared to device operation outside this region.

7.3.3 Rail-to-Rail Input

The input common-mode range extends from $(V-) - 0.2\text{ V}$ to $(V+) + 0.2\text{ V}$. For normal operation, the inputs should be limited to this range. The absolute maximum input voltage is 500 mV beyond the supplies. Inputs greater than the input common-mode range but less than the maximum input voltage, while not valid, do not cause any damage to the op-amp. Unlike some other op-amps, if the input current is limited the inputs may go beyond the power supplies without phase inversion, as shown in Figure 19.

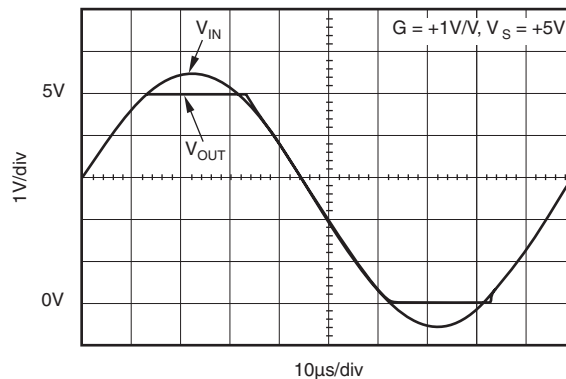

Figure 19. No-Phase Inversion With Inputs Greater Than Power-Supply Voltage

Normally, input currents are 0.5 pA. However, large inputs (greater than 500 mV beyond the supply rails) can cause excessive current to flow in or out of the input pins. Therefore, limiting the input current to less than 10 mA is important as well as keeping the input voltage below the maximum rating. This limiting is easily accomplished with an input voltage resistor, as shown in Figure 20.

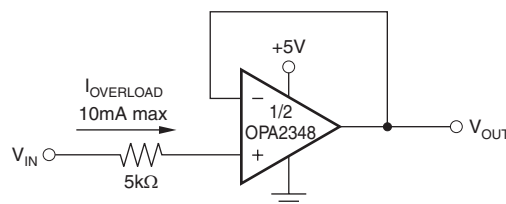

Figure 20. Input Current Protection for Voltages Exceeding the Supply Voltage

Feature Description (continued)

7.3.4 Input and ESD Protection

The OPAx348-Q1 family of devices incorporates internal electrostatic discharge (ESD) protection circuits on all pins. In the case of input and output pins, this protection primarily consists of current-steering diodes connected between the input and power-supply pins. These ESD protection diodes also provide in-circuit, input overdrive protection, as long as the current is limited to 10 mA as stated in the [Absolute Maximum Ratings](#) table. [Figure 21](#) shows how a series input resistor can be added to the driven input to limit the input current. The added resistor contributes thermal noise at the amplifier input and the value should be kept to a minimum in noise-sensitive applications.

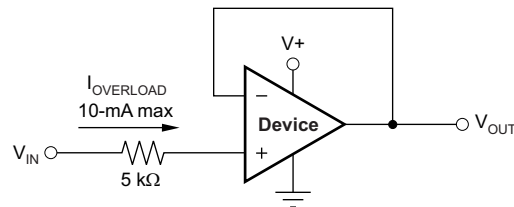

Figure 21. Input Current Protection

7.3.5 Common-Mode Rejection Ratio (CMRR)

CMRR for the OPAx348-Q1 family of devices is specified in several ways so the best match for a given application may be used; see the [Electrical Characteristics](#) table. First, the CMRR of the device in the common-mode range below the transition region [$V_{CM} < (V+) - 1.3$ V] is given. This specification is the best indicator of the capability of the device when the application requires use of one of the differential input pairs. Second, the CMRR over the entire common-mode range is specified at ($V_{CM} = -0.2$ V to 5.7 V). This last value includes the variations seen through the transition region (see [Figure 22](#)).

7.3.6 Common-Mode Voltage Range

The input common-mode voltage range of the OPAx348-Q1 device extends 200 mV beyond the supply rails. This extended range is achieved with a complementary input stage—an N-channel input differential pair in parallel with a P-channel differential pair. The N-channel pair is active for input voltages close to the positive rail, typically $(V+) - 1.2$ V to 300 mV above the positive supply, while the P-channel pair is on for inputs from 300 mV below the negative supply to approximately $(V+) - 1.4$ V. A small transition region exists, typically $(V+) - 1.4$ V to $(V+) - 1.2$ V, in which both pairs are on. This 200-mV transition region, shown in [Figure 22](#), can vary ± 300 mV with process variation. Thus, the transition region (both stages on) can range from $(V+) - 1.7$ V to $(V+) - 1.5$ V on the low end, up to $(V+) - 1.1$ V to $(V+) - 0.9$ V on the high end. Within the 200-mV transition region, PSRR, CMRR, offset voltage, offset drift, and THD may be degraded compared to operation outside this region.

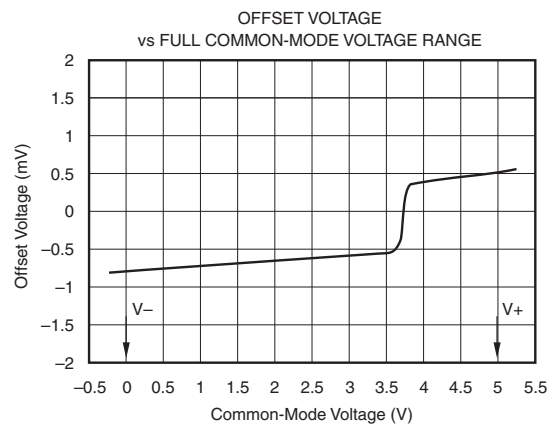

Figure 22. Behavior of Typical Transition Region at Room Temperature

Feature Description (continued)

7.3.7 EMI Susceptibility and Input Filtering

Op-amps vary with regard to the susceptibility of the device to electromagnetic interference (EMI). If conducted EMI enters the op-amp, the dc offset observed at the amplifier output may shift from the nominal value while EMI is present. This shift is a result of signal rectification associated with the internal semiconductor junctions. While all op-amp pin functions can be affected by EMI, the signal input pins are likely to be the most susceptible. The OPAx348-Q1 family of devices incorporates an internal input low-pass filter that reduces the amplifiers response to EMI. Both common-mode and differential mode filtering are provided by this filter. The filter is designed for a cutoff frequency of approximately 80 MHz (–3 dB), with a roll-off of 20 dB per decade.

Texas Instruments has developed the ability to accurately measure and quantify the immunity of an operational amplifier over a broad frequency spectrum extending from 10 MHz to 6 GHz. The EMI rejection ratio (EMIRR) metric allows op-amps to be directly compared by the EMI immunity. Detailed information can also be found in the application report, *EMI Rejection Ratio of Operational Amplifiers (SBOA128)*, available for download from www.ti.com.

7.3.8 Rail-to-Rail Output

Designed as a micro-power, low-noise operational amplifier, the OPAx348-Q1 family of devices delivers a robust output drive capability. A class AB output stage with common-source transistors is used to achieve full rail-to-rail output swing capability. For resistive loads up to 10 k Ω , the output swings typically to within 5 mV of either supply rail regardless of the power-supply voltage applied. Different load conditions change the ability of the amplifier to swing close to the rails; refer to the graph, *Output Voltage Swing vs Output Current*.

A class AB output stage with common-source transistors is used to achieve rail-to-rail output. This output stage is capable of driving 5-k Ω loads connected to any potential between V+ and ground. For light resistive loads (>100 k Ω), the output voltage can typically swing to within 18 mV from supply rail. With moderate resistive loads (10 k Ω to 50 k Ω), the output voltage can typically swing to within 100 mV of the supply rails while maintaining high open-loop gain (see [Figure 6](#) in the *Typical Characteristics* section).

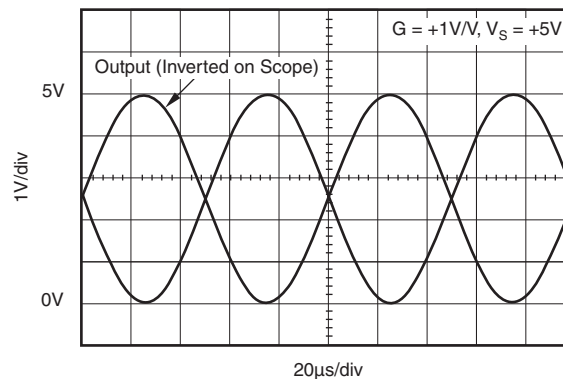

Figure 23. Rail-to-Rail I/O

Feature Description (continued)

7.3.9 Capacitive Load and Stability

The OPAx348-Q1 family of devices in a unity-gain configuration can directly drive up to 250-pF pure capacitive load. Increasing the gain enhances the amplifier's ability to drive greater capacitive loads (see [Figure 13](#) in the [Typical Characteristics](#) section). In unity-gain configurations, capacitive load drive can be improved by inserting a small ($10\ \Omega$ to $20\ \Omega$) resistor, R_S , in series with the output, as shown in [Figure 24](#). This resistor significantly reduces ringing while maintaining DC performance for purely capacitive loads. However, if a resistive load exists in parallel with the capacitive load, a voltage divider is created, introducing a direct current (DC) error at the output and slightly reducing the output swing. The error introduced is proportional to the ratio R_S/R_L and is generally negligible.

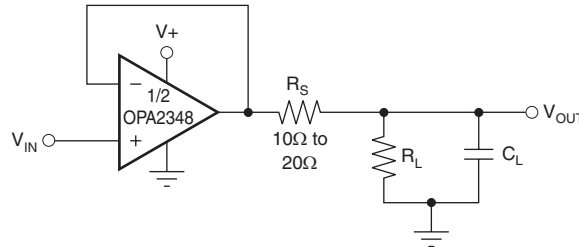

Figure 24. Series Resistor in Unity-Gain Buffer Configuration Improves Capacitive Load Drive

In unity-gain inverter configuration, the phase margin can be reduced by the reaction between the capacitance at the op-amp input and the gain setting resistors, thus degrading capacitive load drive. The best performance is achieved by using small-valued resistors. For example, when driving a 500-pF load, reducing the resistor values from $100\ \text{k}\Omega$ to $5\ \text{k}\Omega$ decreases overshoot from 55% to 13% (see [Figure 13](#) in the [Typical Characteristics](#) section). However, when large valued resistors cannot be avoided, a small ($4\ \text{pF}$ to $6\ \text{pF}$) capacitor, C_{FB} , can be inserted in the feedback, as shown in [Figure 25](#). This small capacitor significantly reduces overshoot by compensating the effect of capacitance, C_{IN} , which includes the input capacitance of the amplifier and PC board parasitic capacitance.

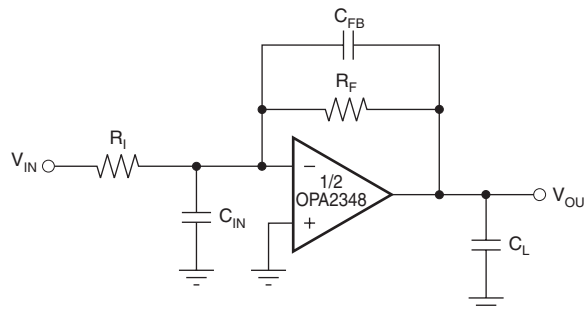

Figure 25. Improving Capacitive Load Drive

7.4 Device Functional Modes

The OPAx348-Q1 family of devices is powered on when the supply is connected. The device can be operated as a single-supply operational amplifier or a dual-supply amplifier, depending on the application.

8 Application and Implementation

NOTE

Information in the following applications sections is not part of the TI component specification, and TI does not warrant its accuracy or completeness. TI's customers are responsible for determining suitability of components for their purposes. Customers should validate and test their design implementation to confirm system functionality.

8.1 Application Information

The OPAx348-Q1 operational amplifiers (op-amps) are unity-gain stable and suitable for a wide range of general-purpose applications.

The OPAx348-Q1 device features wide bandwidth and unity-gain stability with rail-to-rail input and output for increased dynamic range. [Figure 23](#) shows the input and output waveforms for the OPAx348-Q1 device in unity-gain configuration. Operation is from a single 5-V supply with a 100-k Ω load connected to $V_S / 2$. The input is a 5-V_{PP} sinusoid. Output voltage is approximately 4.98 V_{PP}.

The power-supply pins should be bypassed with 0.01- μ F ceramic capacitors.

8.1.1 Driving Analog-to-Digital Converters (ADCs)

The OPAx348-Q1 op-amps are optimized for driving medium-speed sampling ADCs. The OPAx348-Q1 op amps buffer the ADC input capacitance and resulting charge injection while providing signal gain.

[Figure 26](#) shows the OPA2348 in a basic noninverting configuration driving the ADS7822 device. The ADS7822 device is a 12-bit, micropower sampling converter in the MSOP-8 package. When used with the low-power miniature packages of the OPAx348-Q1 family of devices, the combination is ideal for space-limited, low-power applications. In this configuration, an RC network at the ADC input can be used to provide for antialiasing filtering and charge injection current.

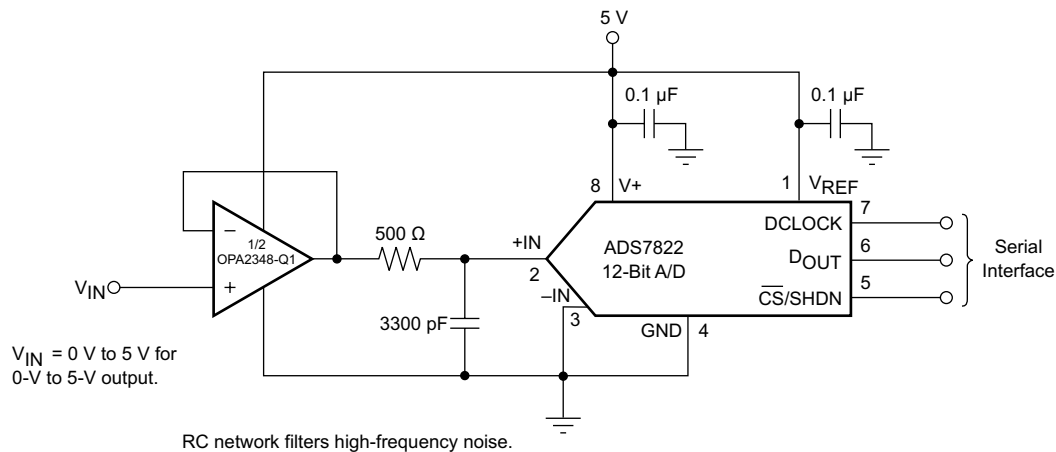

NOTE: A/D Input = 0 to V_{REF}

Figure 26. Noninverting Configuration Driving ADS7822

The OPAx348-Q1 family of devices can also be used in noninverting configuration driving the ADS7822 device in limited low-power applications. In this configuration, an RC network at the ADC input can be used to provide for antialiasing filtering and charge injection current. See [Figure 26](#) for the OPAx348-Q1 driving an ADS7822 device in a speech bandpass filtered data acquisition system. This small low-cost solution provides the necessary amplification and signal conditioning to interface directly with an electret microphone. This circuit operates with $V_S = 2.7$ V to 5 V with less than 250- μ A typical quiescent current.

Application Information (continued)

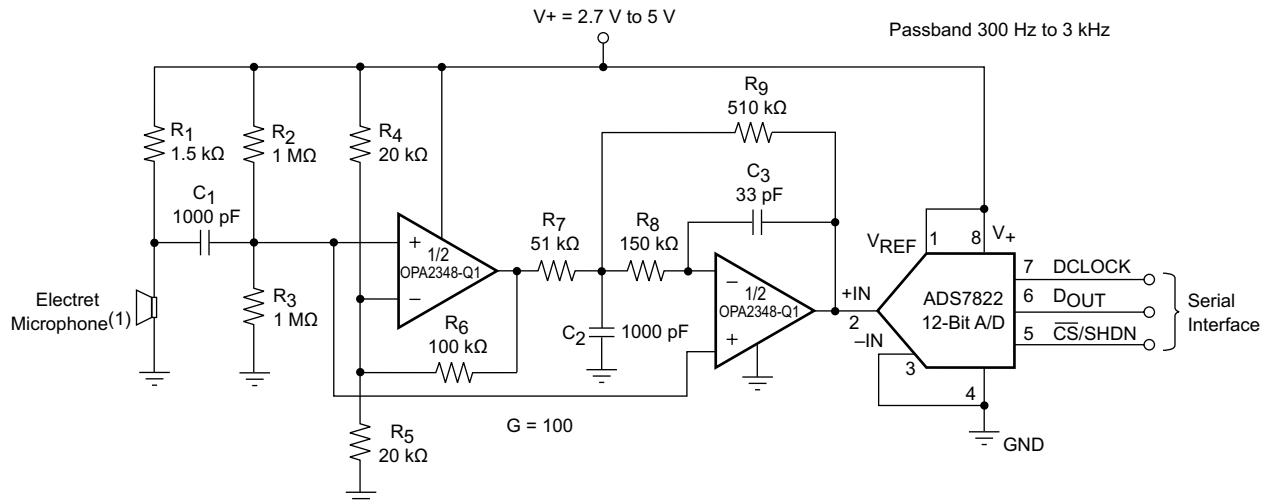

(1) Electret microphone powered by R_1 .

Figure 27. Speech Bandpass Filtered Data Acquisition System

8.2 Typical Application

Some applications require differential signals. Figure 28 shows a simple circuit to convert a single-ended input of 0.1 V to 2.4 V into a differential output of ± 2.3 V on a single 2.7-V supply. The output range is intentionally limited to maximize linearity. The circuit is composed of two amplifiers. One amplifier functions as a buffer and creates a voltage, V_{OUT+} . The second amplifier inverts the input and adds a reference voltage to generate V_{OUT-} . Both V_{OUT+} and V_{OUT-} range from 0.1 V to 2.4 V. The difference, V_{DIFF} , is the difference between V_{OUT+} and V_{OUT-} . This makes the differential output voltage range 2.3 V.

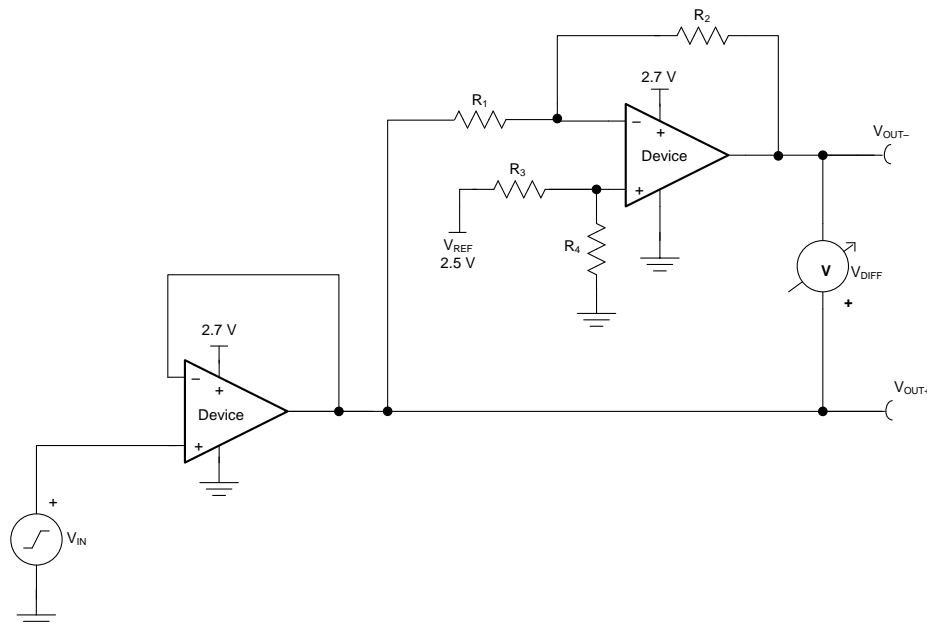

Figure 28. Schematic for a Single-Ended Input to Differential Output Conversion

Typical Application (continued)

8.2.1 Design Requirements

The design requirements are as follows:

- Supply voltage: 2.7 V
- Reference voltage: 2.5 V
- Input: 0.1 V to 2.4 V
- Output differential: ± 2.3 V
- Output common-mode voltage: 1.25 V
- Small-signal bandwidth: 1 MHz

8.2.2 Detailed Design Procedure

The circuit in [Figure 28](#) takes a single-ended input signal, V_{IN} , and generates two output signals, V_{OUT+} and V_{OUT-} using two amplifiers and a reference voltage, V_{REF} . V_{OUT+} is the output of the first amplifier and is a buffered version of the input signal, V_{IN} (as shown in [Equation 1](#)). V_{OUT-} is the output of the second amplifier which uses V_{REF} to add an offset voltage to V_{IN} and feedback to add inverting gain. The transfer function for V_{OUT-} is given in [Equation 2](#).

$$V_{OUT+} = V_{IN} \quad (1)$$

$$V_{OUT-} = V_{REF} \times \left(\frac{R_4}{R_3 + R_4} \right) \times \left(1 + \frac{R_2}{R_1} \right) - V_{IN} \times \frac{R_2}{R_1} \quad (2)$$

The differential output signal, V_{DIFF} , is the difference between the two single-ended output signals, V_{OUT+} and V_{OUT-} . [Equation 3](#) shows the transfer function for V_{DIFF} . By applying the conditions that $R_1 = R_2$ and $R_3 = R_4$, the transfer function is simplified into [Equation 6](#). Using this configuration, the maximum input signal is equal to the reference voltage and the maximum output of each amplifier is equal to V_{REF} . The differential output range is $2 \times V_{REF}$. Furthermore, the common-mode voltage (V_{CM}) is one half of V_{REF} (see [Equation 7](#)).

$$V_{DIFF} = V_{OUT+} - V_{OUT-} = V_{IN} \times \left(1 + \frac{R_2}{R_1} \right) - V_{REF} \times \left(\frac{R_4}{R_3 + R_4} \right) \times \left(1 + \frac{R_2}{R_1} \right) \quad (3)$$

$$V_{OUT+} = V_{IN} \quad (4)$$

$$V_{OUT-} = V_{REF} - V_{IN} \quad (5)$$

$$V_{DIFF} = 2 \times V_{IN} - V_{REF} \quad (6)$$

$$V_{CM} = \left(\frac{V_{OUT+} + V_{OUT-}}{2} \right) = \frac{1}{2} V_{REF} \quad (7)$$

8.2.2.1 Amplifier Selection

Linearity over the input range is key for good dc accuracy. The common-mode input range and output swing limitations determine the linearity. In general, an amplifier with rail-to-rail input and output swing is required. Bandwidth is a key concern for this design, so the OPAx348-Q1 family of devices is selected because its bandwidth is greater than the target of 1 MHz. The bandwidth and power ratio makes this device power efficient and the low offset and drift ensure good accuracy for moderate precision applications.

8.2.2.2 Passive Component Selection

Because the transfer function of V_{out-} is heavily reliant on resistors (R_1 , R_2 , R_3 , and R_4), use resistors with low tolerances to maximize performance and minimize error. This design uses resistors with resistance values of 49.9 k Ω and tolerances of 0.1%. However, if the noise of the system is a key parameter, smaller resistance values (6 k Ω or lower) can be selected to keep the overall system noise low. This ensures that the noise from the resistors is lower than the amplifier noise.

Typical Application (continued)

8.2.3 Application Curves

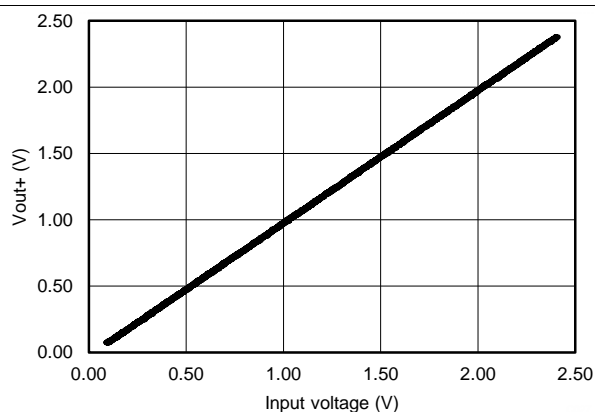

Figure 29. V_{OUT+} vs Input Voltage

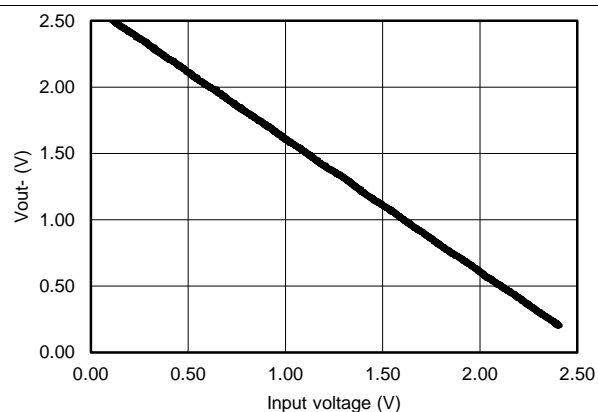

Figure 30. V_{OUT-} vs Input Voltage

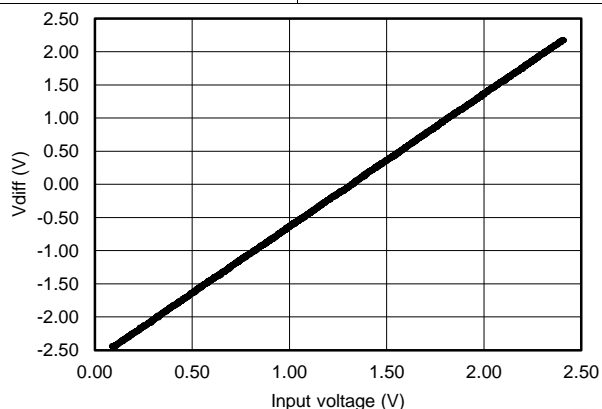

Figure 31. V_{DIFF} vs Input Voltage

9 Power Supply Recommendations

The OPAx348-Q1 family of devices is specified for operation from 1.8 V to 5.5 V (± 0.9 V to ± 2.75 V); many specifications apply from -40°C to 125°C . The [Typical Characteristics](#) presents parameters that can exhibit significant variance with regard to operating voltage or temperature.

CAUTION

Supply voltages larger than 7 V can permanently damage the device (see the [Absolute Maximum Ratings](#)).

Place 0.1- μF bypass capacitors close to the power-supply pins to reduce errors coupling in from noisy or high-impedance power supplies. For more detailed information on bypass capacitor placement, refer to the [Layout Guidelines](#) section.

10 Layout

10.1 Layout Guidelines

For best operational performance of the device, use good PCB layout practices, including:

- Noise can propagate into analog circuitry through the power pins of the circuit as a whole and the operational amplifier. Bypass capacitors are used to reduce the coupled noise by providing low-impedance power sources local to the analog circuitry.
 - Connect low-ESR, 0.1- μ F ceramic bypass capacitors between each supply pin and ground, placed as close to the device as possible. A single bypass capacitor from V+ to ground is applicable for single-supply applications.
- Separate grounding for analog and digital portions of the circuitry is one of the simplest and most effective methods of noise suppression. One or more layers on multilayer PCBs are usually devoted to ground planes. A ground plane helps distribute heat and reduces EMI noise pickup. Make sure to physically separate digital and analog grounds, paying attention to the flow of the ground current. For more detailed information, refer to *Circuit Board Layout Techniques*, [SLOA089](#).
- To reduce parasitic coupling, run the input traces as far away from the supply or output traces as possible. If these traces cannot be kept separate, crossing the sensitive trace perpendicularly is much better than crossing in parallel with the noisy trace.
- Place the external components as close to the device as possible. Keeping RF and RG close to the device minimizes parasitic capacitance, as shown in [Figure 32](#).
- Keep the length of input traces as short as possible. Always remember that the input traces are the most sensitive part of the circuit.
- Consider a driven, low-impedance guard ring around the critical traces. A guard ring can significantly reduce leakage currents from nearby traces that are at different potentials.

10.2 Layout Example

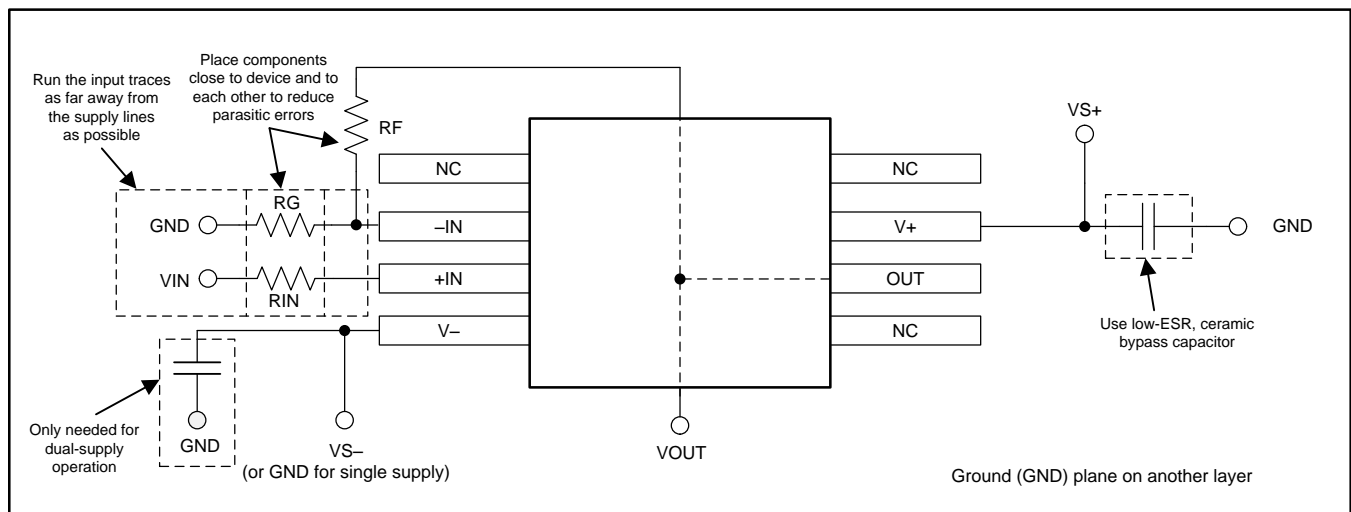
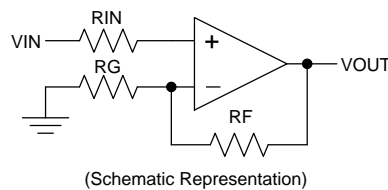

Figure 32. Operational Amplifier Board Layout for Noninverting Configuration

11 Device and Documentation Support

11.1 Documentation Support

11.1.1 Related Documentation

For related documentation see the following:

- *ADS7822 12-Bit, 200kHz, microPower Sampling ANALOG-TO-DIGITAL CONVERTER*, [SBAS062](#)
- *EMI Rejection Ratio of Operational Amplifiers*, [SBOA128](#)

11.2 Related Links

The table below lists quick access links. Categories include technical documents, support and community resources, tools and software, and quick access to sample or buy.

Table 1. Related Links

PARTS	PRODUCT FOLDER	SAMPLE & BUY	TECHNICAL DOCUMENTS	TOOLS & SOFTWARE	SUPPORT & COMMUNITY
OPA348-Q1	Click here	Click here	Click here	Click here	Click here
OPA2348-Q1	Click here	Click here	Click here	Click here	Click here
OPA4348-Q1	Click here	Click here	Click here	Click here	Click here

11.3 Trademarks

All trademarks are the property of their respective owners.

11.4 Electrostatic Discharge Caution



These devices have limited built-in ESD protection. The leads should be shorted together or the device placed in conductive foam during storage or handling to prevent electrostatic damage to the MOS gates.

11.5 Glossary

[SLYZ022](#) — *TI Glossary*.

This glossary lists and explains terms, acronyms, and definitions.

12 Mechanical, Packaging, and Orderable Information

The following pages include mechanical, packaging, and orderable information. This information is the most current data available for the designated devices. This data is subject to change without notice and revision of this document. For browser-based versions of this data sheet, refer to the left-hand navigation.

PACKAGING INFORMATION

Orderable Device	Status (1)	Package Type	Package Drawing	Pins	Package Qty	Eco Plan (2)	Lead/Ball Finish (6)	MSL Peak Temp (3)	Op Temp (°C)	Device Marking (4/5)	Samples
OPA2348AQDRQ1	ACTIVE	SOIC	D	8	2500	Green (RoHS & no Sb/Br)	CU NIPDAU	Level-2-260C-1 YEAR	-40 to 125	OPA 2348Q	Samples
OPA348AQDBVRQ1	ACTIVE	SOT-23	DBV	5	3000	Green (RoHS & no Sb/Br)	CU NIPDAU	Level-2-260C-1 YEAR	-40 to 125	A48	Samples
OPA348AQDRQ1	ACTIVE	SOIC	D	8	2500	Green (RoHS & no Sb/Br)	CU NIPDAU	Level-2-260C-1 YEAR	-40 to 125	348Q1	Samples
OPA4348AQPWRQ1	ACTIVE	TSSOP	PW	14	2500	Green (RoHS & no Sb/Br)	CU NIPDAU	Level-3-260C-168 HR	-40 to 125	OP4348Q	Samples

(1) The marketing status values are defined as follows:

ACTIVE: Product device recommended for new designs.

LIFEBUY: TI has announced that the device will be discontinued, and a lifetime-buy period is in effect.

NRND: Not recommended for new designs. Device is in production to support existing customers, but TI does not recommend using this part in a new design.

PREVIEW: Device has been announced but is not in production. Samples may or may not be available.

OBSELETE: TI has discontinued the production of the device.

(2) Eco Plan - The planned eco-friendly classification: Pb-Free (RoHS), Pb-Free (RoHS Exempt), or Green (RoHS & no Sb/Br) - please check <http://www.ti.com/productcontent> for the latest availability information and additional product content details.

TBD: The Pb-Free/Green conversion plan has not been defined.

Pb-Free (RoHS): TI's terms "Lead-Free" or "Pb-Free" mean semiconductor products that are compatible with the current RoHS requirements for all 6 substances, including the requirement that lead not exceed 0.1% by weight in homogeneous materials. Where designed to be soldered at high temperatures, TI Pb-Free products are suitable for use in specified lead-free processes.

Pb-Free (RoHS Exempt): This component has a RoHS exemption for either 1) lead-based flip-chip solder bumps used between the die and package, or 2) lead-based die adhesive used between the die and leadframe. The component is otherwise considered Pb-Free (RoHS compatible) as defined above.

Green (RoHS & no Sb/Br): TI defines "Green" to mean Pb-Free (RoHS compatible), and free of Bromine (Br) and Antimony (Sb) based flame retardants (Br or Sb do not exceed 0.1% by weight in homogeneous material)

(3) MSL, Peak Temp. - The Moisture Sensitivity Level rating according to the JEDEC industry standard classifications, and peak solder temperature.

(4) There may be additional marking, which relates to the logo, the lot trace code information, or the environmental category on the device.

(5) Multiple Device Markings will be inside parentheses. Only one Device Marking contained in parentheses and separated by a "~" will appear on a device. If a line is indented then it is a continuation of the previous line and the two combined represent the entire Device Marking for that device.

(6) Lead/Ball Finish - Orderable Devices may have multiple material finish options. Finish options are separated by a vertical ruled line. Lead/Ball Finish values may wrap to two lines if the finish value exceeds the maximum column width.

Important Information and Disclaimer: The information provided on this page represents TI's knowledge and belief as of the date that it is provided. TI bases its knowledge and belief on information provided by third parties, and makes no representation or warranty as to the accuracy of such information. Efforts are underway to better integrate information from third parties. TI has taken and continues to take reasonable steps to provide representative and accurate information but may not have conducted destructive testing or chemical analysis on incoming materials and chemicals. TI and TI suppliers consider certain information to be proprietary, and thus CAS numbers and other limited information may not be available for release.

In no event shall TI's liability arising out of such information exceed the total purchase price of the TI part(s) at issue in this document sold by TI to Customer on an annual basis.

OTHER QUALIFIED VERSIONS OF OPA2348-Q1, OPA348-Q1, OPA4348-Q1 :

- Catalog: [OPA2348](#), [OPA348](#), [OPA4348](#)

NOTE: Qualified Version Definitions:

- Catalog - TI's standard catalog product

TAPE AND REEL INFORMATION



QUADRANT ASSIGNMENTS FOR PIN 1 ORIENTATION IN TAPE



*All dimensions are nominal

Device	Package Type	Package Drawing	Pins	SPQ	Reel Diameter (mm)	Reel Width W1 (mm)	A0 (mm)	B0 (mm)	K0 (mm)	P1 (mm)	W (mm)	Pin1 Quadrant
OPA2348AQDRQ1	SOIC	D	8	2500	330.0	12.4	6.4	5.2	2.1	8.0	12.0	Q1
OPA348AQDBVRQ1	SOT-23	DBV	5	3000	178.0	9.0	3.3	3.2	1.4	4.0	8.0	Q3
OPA348AQDRQ1	SOIC	D	8	2500	330.0	12.4	6.4	5.2	2.1	8.0	12.0	Q1
OPA4348AQPWRQ1	TSSOP	PW	14	2500	330.0	12.4	6.9	5.6	1.6	8.0	12.0	Q1

TAPE AND REEL BOX DIMENSIONS

*All dimensions are nominal

Device	Package Type	Package Drawing	Pins	SPQ	Length (mm)	Width (mm)	Height (mm)
OPA2348AQDRQ1	SOIC	D	8	2500	367.0	367.0	35.0
OPA348AQDBVRQ1	SOT-23	DBV	5	3000	180.0	180.0	18.0
OPA348AQDRQ1	SOIC	D	8	2500	367.0	367.0	35.0
OPA4348AQPWRQ1	TSSOP	PW	14	2500	367.0	367.0	35.0

DBV (R-PDSO-G5)

PLASTIC SMALL-OUTLINE PACKAGE

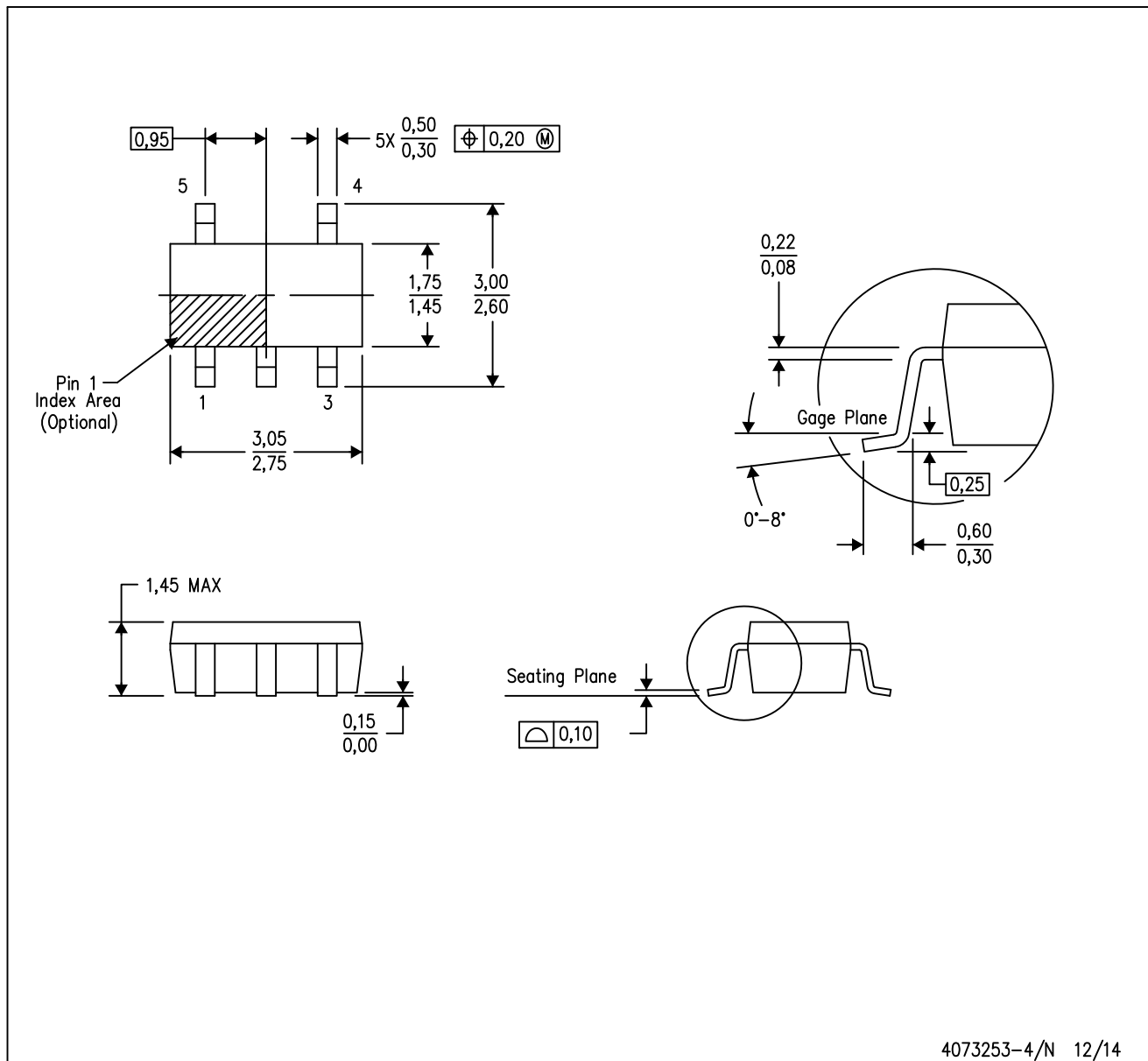

- NOTES:
- A. All linear dimensions are in millimeters.
 - B. This drawing is subject to change without notice.
 - C. Body dimensions do not include mold flash or protrusion. Mold flash and protrusion shall not exceed 0.15 per side.
 - D. Falls within JEDEC MO-178 Variation AA.

DBV (R-PDSO-G5)

PLASTIC SMALL OUTLINE

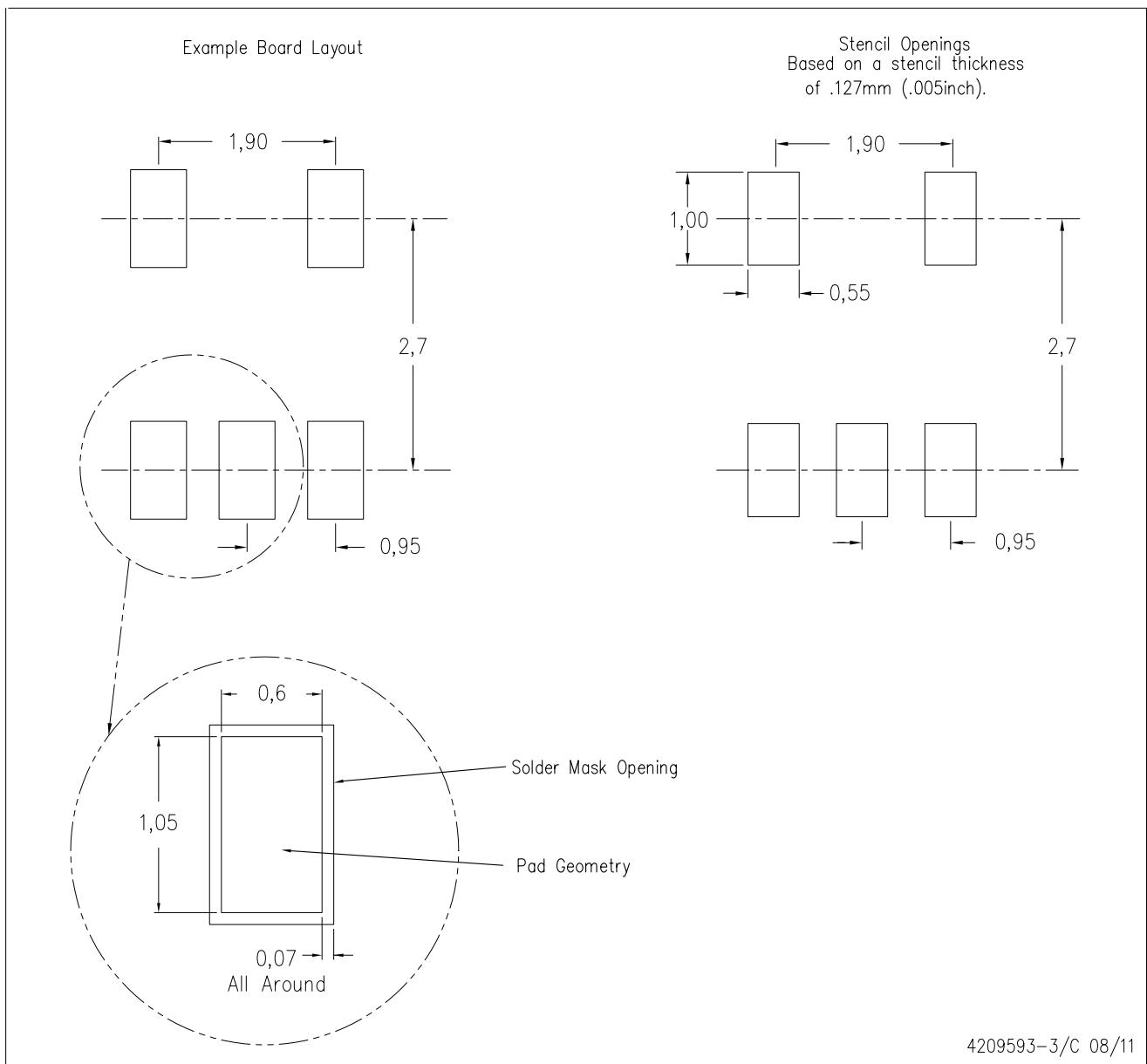

- NOTES:
- A. All linear dimensions are in millimeters.
 - B. This drawing is subject to change without notice.
 - C. Customers should place a note on the circuit board fabrication drawing not to alter the center solder mask defined pad.
 - D. Publication IPC-7351 is recommended for alternate designs.
 - E. Laser cutting apertures with trapezoidal walls and also rounding corners will offer better paste release. Customers should contact their board assembly site for stencil design recommendations. Example stencil design based on a 50% volumetric metal load solder paste. Refer to IPC-7525 for other stencil recommendations.

PW (R-PDSO-G14)

PLASTIC SMALL OUTLINE



4211284-2/G 08/15

- NOTES:
- All linear dimensions are in millimeters.
 - This drawing is subject to change without notice.
 - Publication IPC-7351 is recommended for alternate designs.
 - Laser cutting apertures with trapezoidal walls and also rounding corners will offer better paste release. Customers should contact their board assembly site for stencil design recommendations. Refer to IPC-7525 for other stencil recommendations.
 - Customers should contact their board fabrication site for solder mask tolerances between and around signal pads.

D (R-PDSO-G8)

PLASTIC SMALL OUTLINE

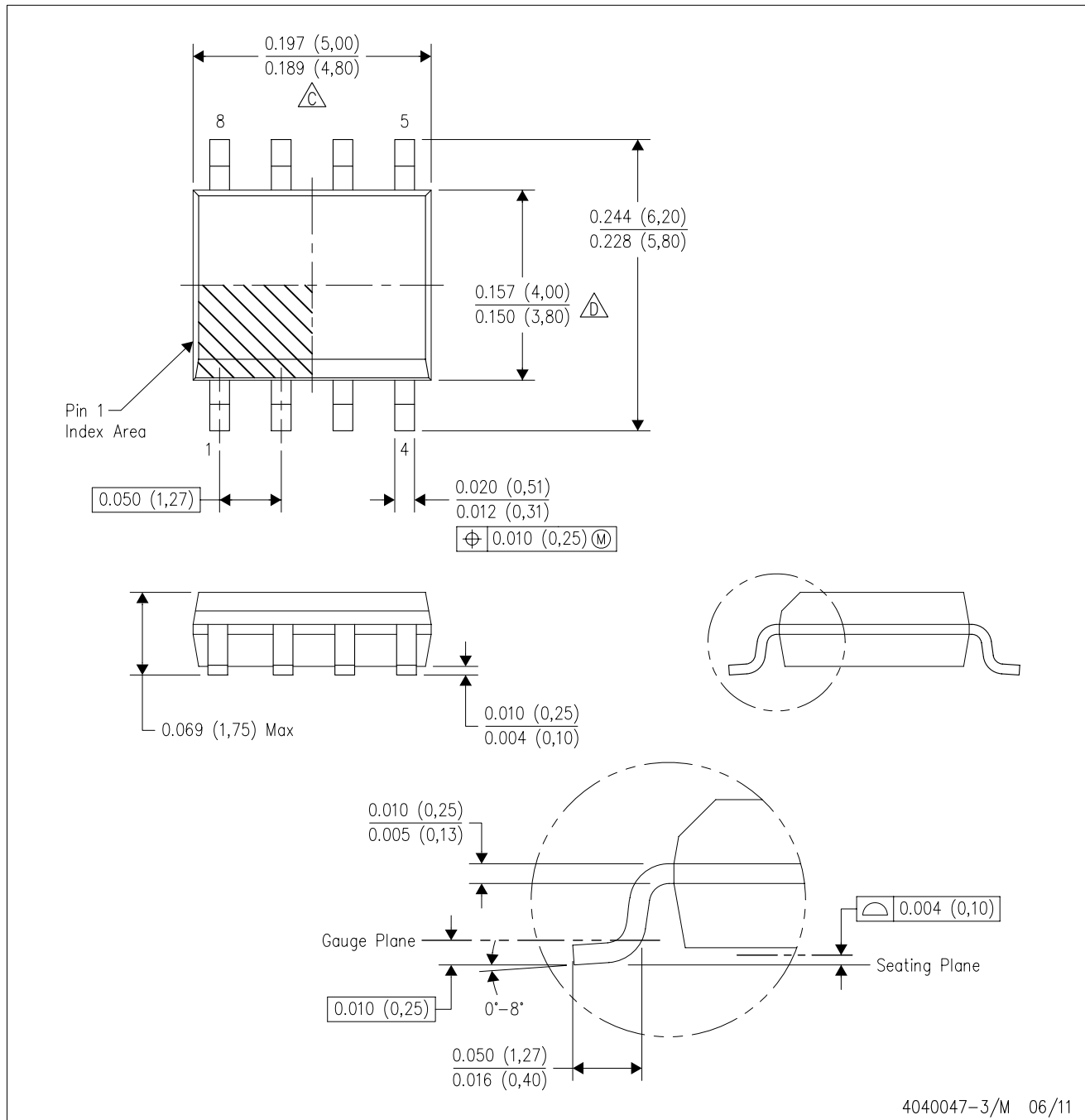

- NOTES:
- A. All linear dimensions are in inches (millimeters).
 - B. This drawing is subject to change without notice.
 - C. Body length does not include mold flash, protrusions, or gate burrs. Mold flash, protrusions, or gate burrs shall not exceed 0.006 (0,15) each side.
 - D. Body width does not include interlead flash. Interlead flash shall not exceed 0.017 (0,43) each side.
 - E. Reference JEDEC MS-012 variation AA.

D (R-PDSO-G8)

PLASTIC SMALL OUTLINE



4211283-2/E 08/12

- NOTES:
- A. All linear dimensions are in millimeters.
 - B. This drawing is subject to change without notice.
 - C. Publication IPC-7351 is recommended for alternate designs.
 - D. Laser cutting apertures with trapezoidal walls and also rounding corners will offer better paste release. Customers should contact their board assembly site for stencil design recommendations. Refer to IPC-7525 for other stencil recommendations.
 - E. Customers should contact their board fabrication site for solder mask tolerances between and around signal pads.

IMPORTANT NOTICE

Texas Instruments Incorporated and its subsidiaries (TI) reserve the right to make corrections, enhancements, improvements and other changes to its semiconductor products and services per JESD46, latest issue, and to discontinue any product or service per JESD48, latest issue. Buyers should obtain the latest relevant information before placing orders and should verify that such information is current and complete. All semiconductor products (also referred to herein as "components") are sold subject to TI's terms and conditions of sale supplied at the time of order acknowledgment.

TI warrants performance of its components to the specifications applicable at the time of sale, in accordance with the warranty in TI's terms and conditions of sale of semiconductor products. Testing and other quality control techniques are used to the extent TI deems necessary to support this warranty. Except where mandated by applicable law, testing of all parameters of each component is not necessarily performed.

TI assumes no liability for applications assistance or the design of Buyers' products. Buyers are responsible for their products and applications using TI components. To minimize the risks associated with Buyers' products and applications, Buyers should provide adequate design and operating safeguards.

TI does not warrant or represent that any license, either express or implied, is granted under any patent right, copyright, mask work right, or other intellectual property right relating to any combination, machine, or process in which TI components or services are used. Information published by TI regarding third-party products or services does not constitute a license to use such products or services or a warranty or endorsement thereof. Use of such information may require a license from a third party under the patents or other intellectual property of the third party, or a license from TI under the patents or other intellectual property of TI.

Reproduction of significant portions of TI information in TI data books or data sheets is permissible only if reproduction is without alteration and is accompanied by all associated warranties, conditions, limitations, and notices. TI is not responsible or liable for such altered documentation. Information of third parties may be subject to additional restrictions.

Resale of TI components or services with statements different from or beyond the parameters stated by TI for that component or service voids all express and any implied warranties for the associated TI component or service and is an unfair and deceptive business practice. TI is not responsible or liable for any such statements.

Buyer acknowledges and agrees that it is solely responsible for compliance with all legal, regulatory and safety-related requirements concerning its products, and any use of TI components in its applications, notwithstanding any applications-related information or support that may be provided by TI. Buyer represents and agrees that it has all the necessary expertise to create and implement safeguards which anticipate dangerous consequences of failures, monitor failures and their consequences, lessen the likelihood of failures that might cause harm and take appropriate remedial actions. Buyer will fully indemnify TI and its representatives against any damages arising out of the use of any TI components in safety-critical applications.

In some cases, TI components may be promoted specifically to facilitate safety-related applications. With such components, TI's goal is to help enable customers to design and create their own end-product solutions that meet applicable functional safety standards and requirements. Nonetheless, such components are subject to these terms.

No TI components are authorized for use in FDA Class III (or similar life-critical medical equipment) unless authorized officers of the parties have executed a special agreement specifically governing such use.

Only those TI components which TI has specifically designated as military grade or "enhanced plastic" are designed and intended for use in military/aerospace applications or environments. Buyer acknowledges and agrees that any military or aerospace use of TI components which have **not** been so designated is solely at the Buyer's risk, and that Buyer is solely responsible for compliance with all legal and regulatory requirements in connection with such use.

TI has specifically designated certain components as meeting ISO/TS16949 requirements, mainly for automotive use. In any case of use of non-designated products, TI will not be responsible for any failure to meet ISO/TS16949.

Products

Audio	www.ti.com/audio
Amplifiers	amplifier.ti.com
Data Converters	dataconverter.ti.com
DLP® Products	www.dlp.com
DSP	dsp.ti.com
Clocks and Timers	www.ti.com/clocks
Interface	interface.ti.com
Logic	logic.ti.com
Power Mgmt	power.ti.com
Microcontrollers	microcontroller.ti.com
RFID	www.ti-rfid.com
OMAP Applications Processors	www.ti.com/omap
Wireless Connectivity	www.ti.com/wirelessconnectivity

Applications

Automotive and Transportation	www.ti.com/automotive
Communications and Telecom	www.ti.com/communications
Computers and Peripherals	www.ti.com/computers
Consumer Electronics	www.ti.com/consumer-apps
Energy and Lighting	www.ti.com/energy
Industrial	www.ti.com/industrial
Medical	www.ti.com/medical
Security	www.ti.com/security
Space, Avionics and Defense	www.ti.com/space-avionics-defense
Video and Imaging	www.ti.com/video

TI E2E Community

e2e.ti.com