

1.8V, 7MHz, 90dB CMRR, Single-Supply, Rail-to-Rail I/O Operational Amplifier

Check for Samples: [OPA363](#), [OPA2363](#), [OPA364](#), [OPA2364](#), [OPA4364](#)

FEATURES

- 1.8V Operation
- *MicroSize* Packages
- Bandwidth: 7MHz
- CMRR: 90dB (typical)
- Slew Rate: 5V/μs
- Low Offset: 500μV (max)
- Quiescent Current: 750μA/Channel (max)
- Shutdown Mode: < 1μA/Channel

APPLICATIONS

- Signal Conditioning
- Data Acquisition
- Process Control
- Active Filters
- Test Equipment

DESCRIPTION

The OPA363 and OPA364 families are high-performance CMOS operational amplifiers optimized for very low voltage, single-supply operation. These miniature, low-cost amplifiers are designed to operate on single supplies from 1.8V ($\pm 0.9V$) to 5.5V ($\pm 2.75V$). Applications include sensor amplification and signal conditioning in battery-powered systems.

The OPA363 and OPA364 families offer excellent CMRR without the crossover associated with traditional complimentary input stages. This results in excellent performance for driving Analog-to-Digital (A/D) converters without degradation of differential linearity and THD. The input commonmode range includes both the negative and positive supplies. The output voltage swing is within 10mV of the rails.

The OPA363 family includes a shutdown mode. Under logic control, the amplifiers can be switched from normal operation to a standby current that is less than 1μA.

The single version is available in the *MicroSize* SOT23-5 (SOT23-6 for shutdown) and SO-8. The dual version is available in MSOP-8, MSOP-10, UQFN-16, and SO-8 packages. Quad packages are available in TSSOP-14 and SO-14 packages. All versions are specified for operation from $-40^{\circ}C$ to $+125^{\circ}C$.

	OPA363	OPA364	OPA2363	OPA2364	OPA4364
SOT23-5		X			
SOT23-6	X				
MSOP-8				X	
MSOP-10			X		
SO-8	X	X		X	
TSSOP-14					X
SO-14					X
UQFN-16			X		



Please be aware that an important notice concerning availability, standard warranty, and use in critical applications of Texas Instruments semiconductor products and disclaimers thereto appears at the end of this data sheet.

All trademarks are the property of their respective owners.

ELECTRICAL CHARACTERISTICS: $V_S = +1.8V$ to $+5.5V$ (continued)
Boldface limits apply over the specified temperature range, $T_A = -40^{\circ}C$ to $+125^{\circ}C$.

 At $T_A = +25^{\circ}C$, $R_L = 10k\Omega$ connected to $V_S/2$, $V_{OUT} = V_S/2$, and $V_{CM} = V_S/2$, unless otherwise noted.

PARAMETER	CONDITIONS	OPAx363, OPAx364			UNIT
		MIN	TYP	MAX	
INPUT CAPACITANCE					
Differential			2		pF
Common-Mode			3		pF
OPEN-LOOP GAIN					
Open-Loop Voltage Gain	$R_L = 10k\Omega$, $100mV < V_O < (V+) - 100mV$	94	100		dB
OPA4364AI		90			dB
over Temperature	$V_S = 1.8V$ to $5.5V$	86			dB
FREQUENCY RESPONSE					
Gain-Bandwidth Product	$C_L = 100pF$		7		MHz
Slew Rate	$G = +1$		5		V/ μs
Settling Time, 0.1%	$V_S = +5V$, 4V Step, $G = +1$		1		μs
0.01%	$V_S = +5V$, 4V Step, $G = +1$		1.5		μs
Overload Recovery Time	$V_{IN} \cdot \text{Gain} > V_S$		0.8		μs
Total Harmonic Distortion + Noise	$V_S = +5V$, $G = +1$, $f = 20kHz$ to $20kHz$		0.002		%
OUTPUT					
Voltage Output Swing	$R_L = 10k\Omega$		10	20	V
Over Temperature	$R_L = 10k\Omega$			20	V
Short-Circuit Current	I_{SC}	See Typical Characteristics			
Capacitive Load Drive	C_{LOAD}	See Typical Characteristics			
SHUTDOWN (for OPAx363)					
t_{OFF}			1		μs
$t_{ON}^{(1)}$			20		μs
V_I (shutdown)				$(V-) + 0.8$	V
V_h (amplifier is active)		0.75 (V+)		5.5	V
I_{QSD}				0.9	μA
POWER SUPPLY					
Specified Voltage Range	V_S	1.8		5.5	V
Operating Voltage Range			1.8 to 5.5		V
Quiescent Current (per amplifier)	I_Q	$V_S = +1.8V$	650	750	μA
		$V_S = +3.6V$	850	1000	μA
		$V_S = +5.5V$	1.1	1.4	mA
TEMPERATURE RANGE					
Specified Range		-40		+125	$^{\circ}C$
Operating Range		-40		+150	$^{\circ}C$
Storage Range		-65		+150	$^{\circ}C$
Thermal Resistance	θ_{JA}				
SOT23-5, SOT23-6			200		$^{\circ}C/W$
MSOP-8, MSOP-10, SO-8			150		$^{\circ}C/W$
TSSOP-14, SO-14			100		$^{\circ}C/W$

(1) Part is considered enabled when input offset voltage returns to specified range.

PIN CONFIGURATION

**OPA363⁽¹⁾: DBV PACKAGE
SOT23-6
(TOP VIEW)**

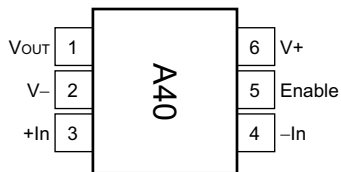

**OPA364⁽¹⁾: DBV PACKAGE
SOT23-5
(TOP VIEW)**

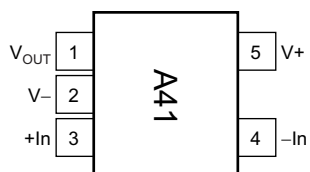

**OPA2363: RSV PACKAGE
UQFN-16
(TOP VIEW)**

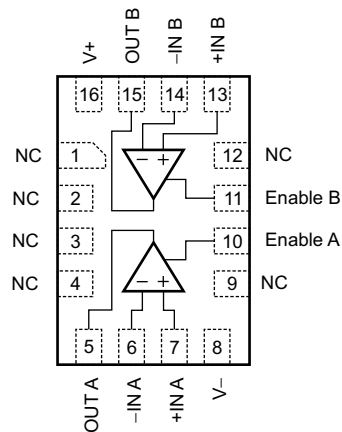

**OPA363: D PACKAGE
SO-8
(TOP VIEW)**

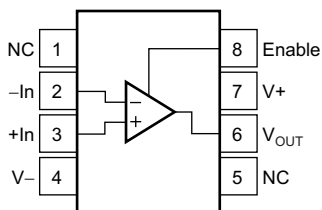

**OPA2364: DGK, D PACKAGES
MSOP-8, SO-8
(TOP VIEW)**

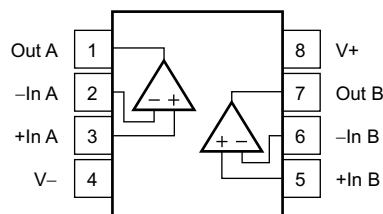

**OPA364: D PACKAGE
SO-8
(TOP VIEW)**

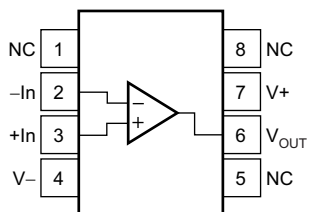

**OPA4364: D, PW PACKAGES
SO-14, TSSOP-14
(TOP VIEW)**

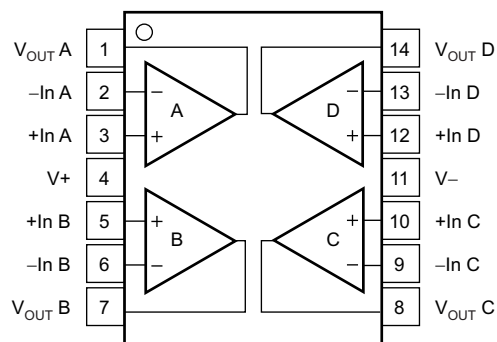

**OPA2363: DGS PACKAGE
MSOP-10
(TOP VIEW)**

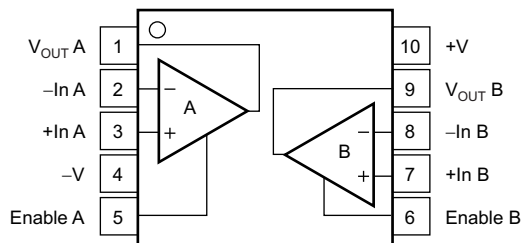

(1) Orient according to marking.

NOTE: NC = No internal connection.

TYPICAL CHARACTERISTICS

At $T_A = +25^\circ\text{C}$, $R_L = 10\text{k}\Omega$ connected to $V_S/2$, $V_{OUT} = V_S/2$, and $V_{CM} = V_S/2$, unless otherwise noted.

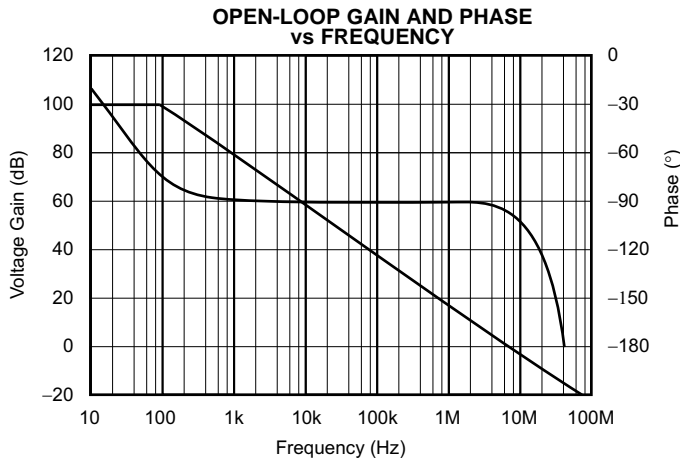

Figure 1.

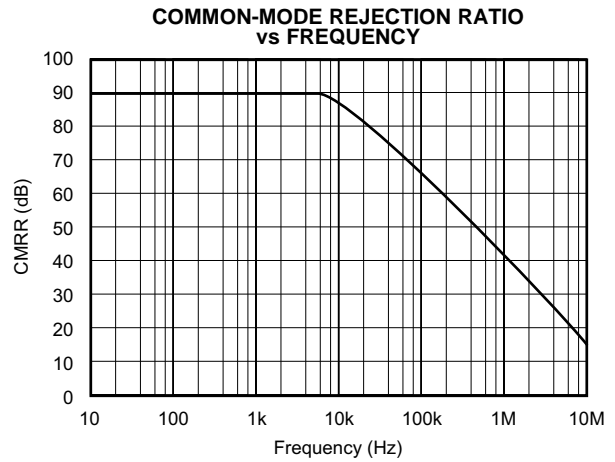

Figure 2.

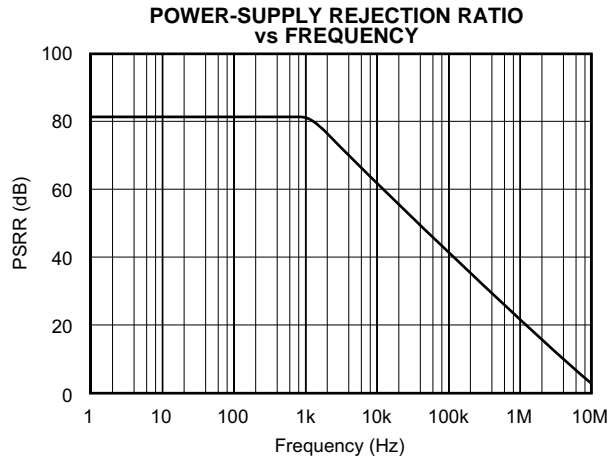

Figure 3.

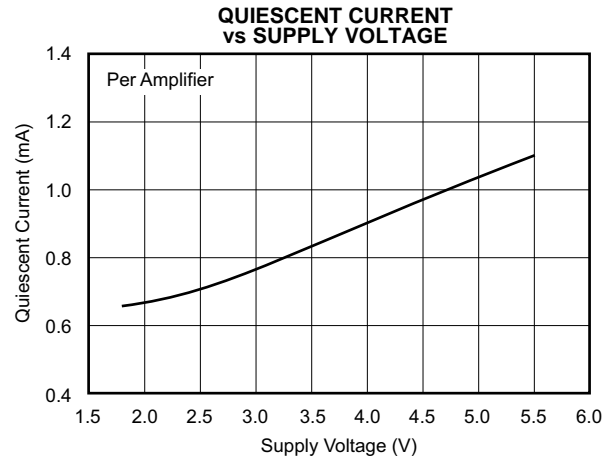

Figure 4.

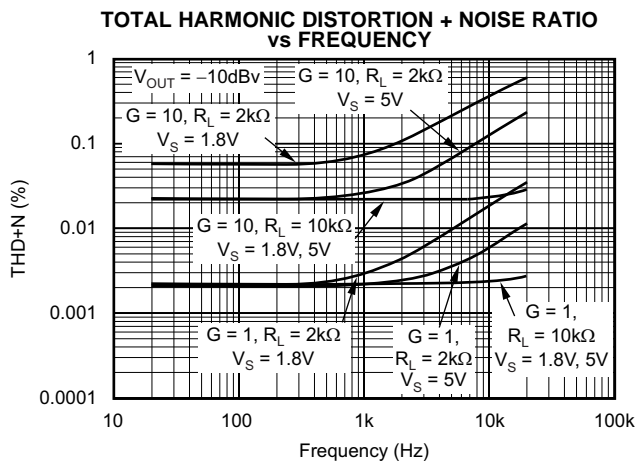

Figure 5.

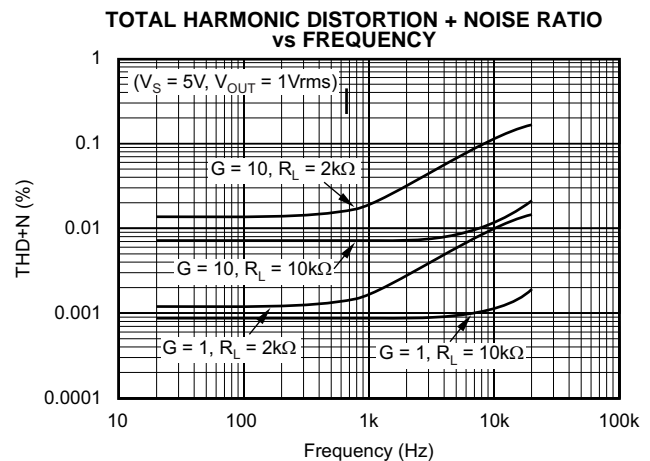
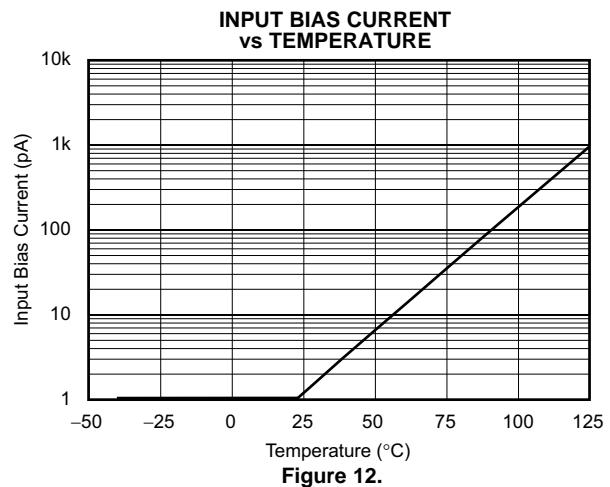
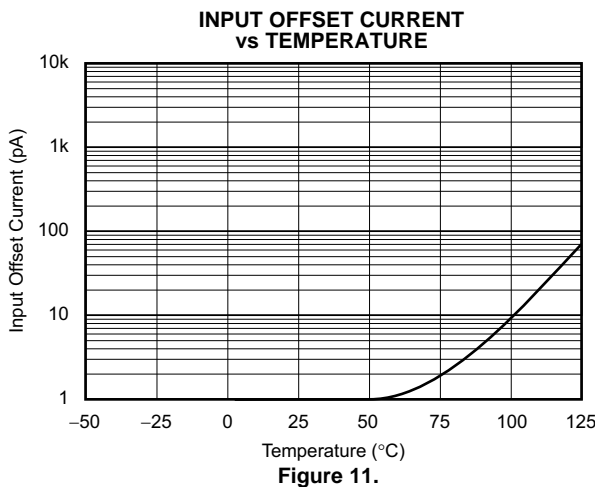
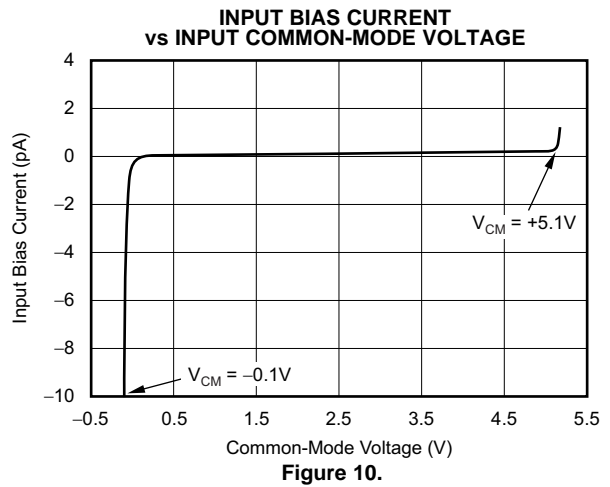
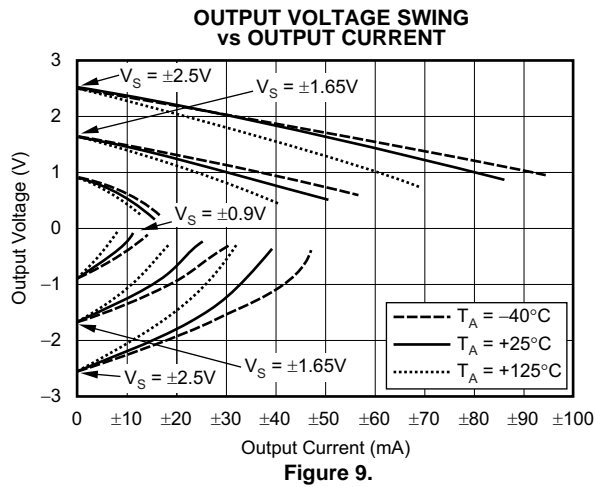
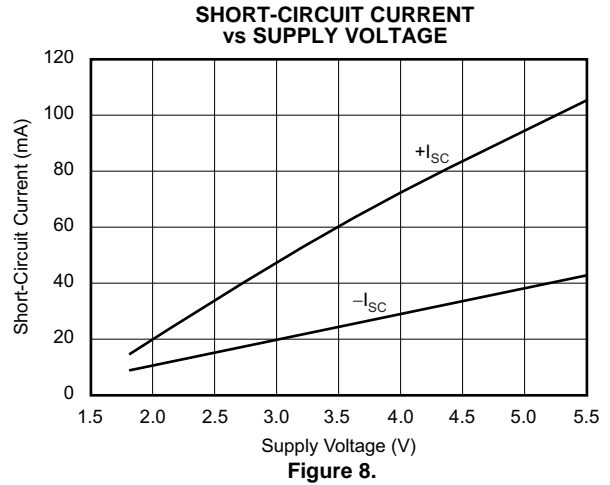
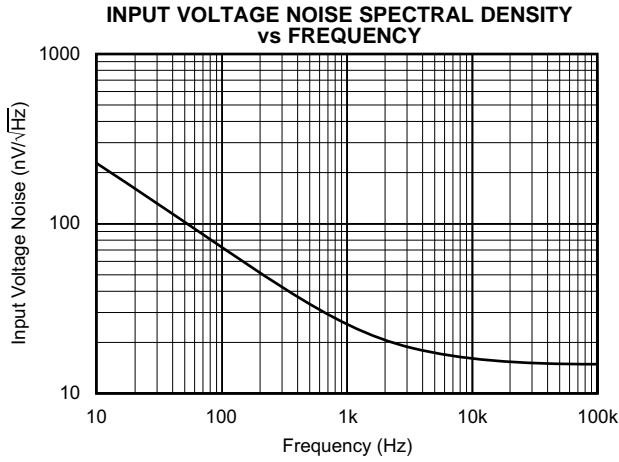

Figure 6.

TYPICAL CHARACTERISTICS (continued)

At $T_A = +25^\circ\text{C}$, $R_L = 10\text{k}\Omega$ connected to $V_S/2$, $V_{OUT} = V_S/2$, and $V_{CM} = V_S/2$, unless otherwise noted.



TYPICAL CHARACTERISTICS (continued)

At $T_A = +25^\circ\text{C}$, $R_L = 10\text{k}\Omega$ connected to $V_S/2$, $V_{OUT} = V_S/2$, and $V_{CM} = V_S/2$, unless otherwise noted.

SMALL-SIGNAL OVERSHOOT vs LOAD CAPACITANCE

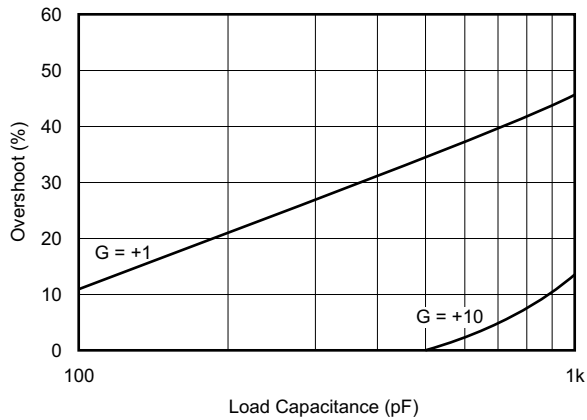

Figure 13.

SETTLING TIME vs CLOSED-LOOP GAIN

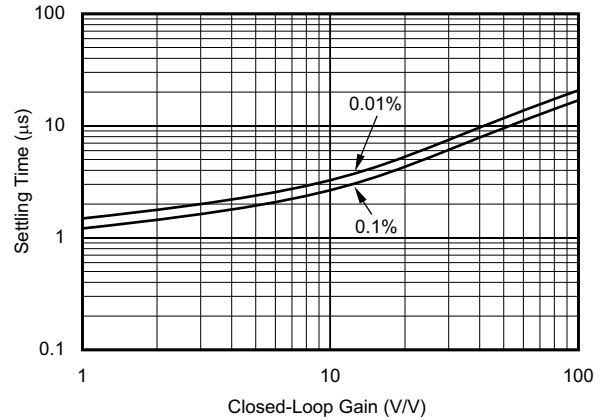

Figure 14.

OFFSET DRIFT DISTRIBUTION

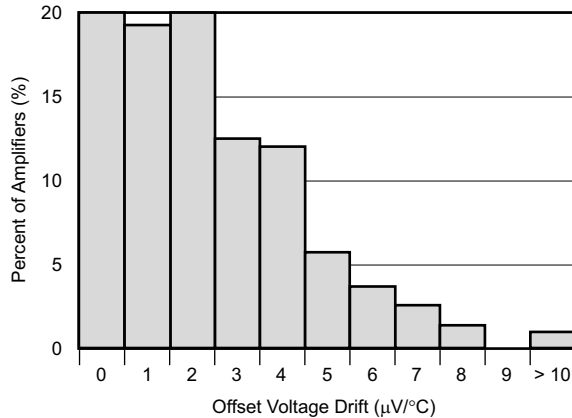

Figure 15.

OFFSET VOLTAGE PRODUCTION DISTRIBUTION

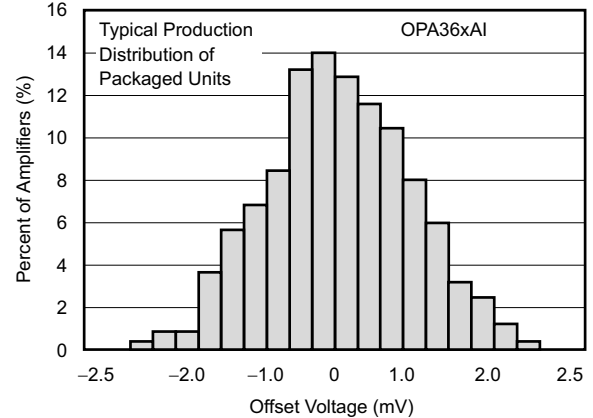

Figure 16.

OUTPUT ENABLE CHARACTERISTIC
($V_S = 5\text{V}$, $V_{OUT} = 20\text{kHz Sinusoid}$)

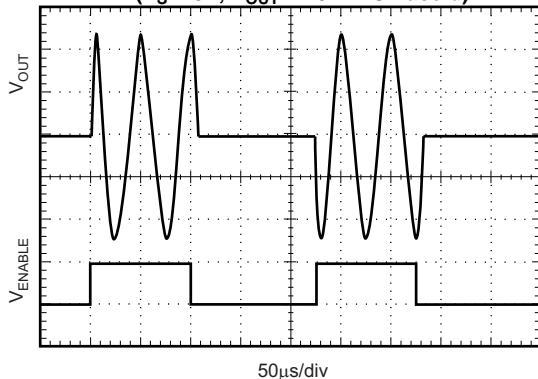

Figure 17.

CHANNEL SEPARATION vs FREQUENCY

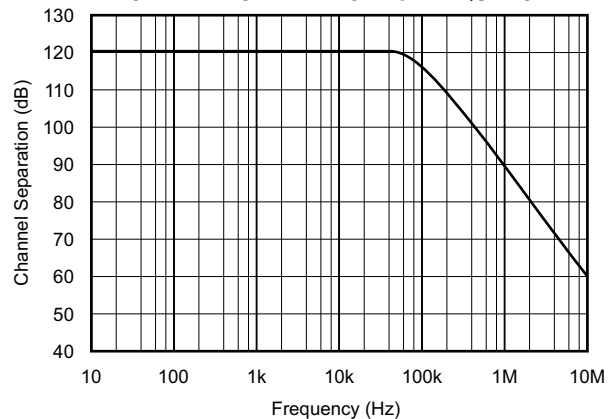
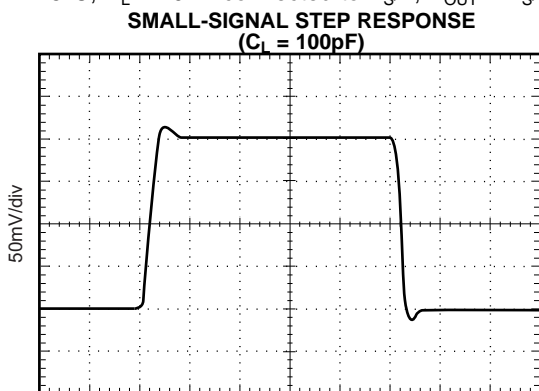

Figure 18.

TYPICAL CHARACTERISTICS (continued)

At $T_A = +25^\circ\text{C}$, $R_L = 10\text{k}\Omega$ connected to $V_S/2$, $V_{OUT} = V_S/2$, and $V_{CM} = V_S/2$, unless otherwise noted.



250ns/div
Figure 19.

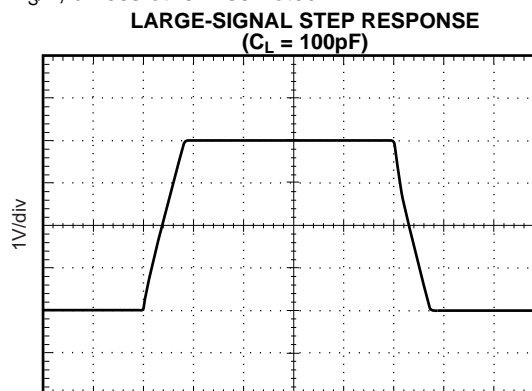

1µs/div
Figure 20.

APPLICATION INFORMATION

The OPA363 and OPA364 series op amps are rail-to-rail operational amplifiers with excellent CMRR, low noise, low offset, and wide bandwidth on supply voltages as low as $\pm 0.9\text{V}$. The OPA363 features an additional pin for shutdown/ enable function. These families do not exhibit phase reversal and are unity-gain stable. Specified over the industrial temperature range of -40°C to $+125^\circ\text{C}$, the OPA363 and OPA364 families offer precision performance for a wide range of applications.

RAIL-TO-RAIL INPUT

The OPA363 and OPA364 feature excellent rail-to-rail operation, with supply voltages as low as $\pm 0.9\text{V}$. The input common-mode voltage range of the OPA363 and OPA364 family extends 100mV beyond supply rails. The unique input topology of the OPA363 and OPA364 eliminates the input offset transition region typical of most rail-to-rail complimentary stage operational amplifiers, allowing the OPA363 and OPA364 to provide superior common-mode performance over the entire common-mode input range, as seen in [Figure 21](#). This feature prevents degradation of the differential linearity error and THD when driving A/D converters. A simplified schematic of the OPA363 and OPA364 is shown in [Figure 22](#).

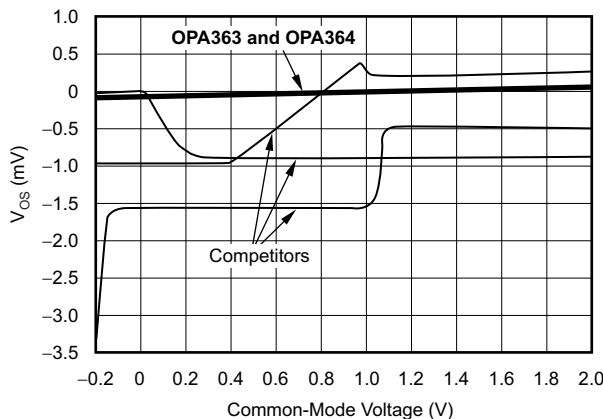

Figure 21. OPA363 and OPA364 have Linear Offset Over Entire Common-Mode Range

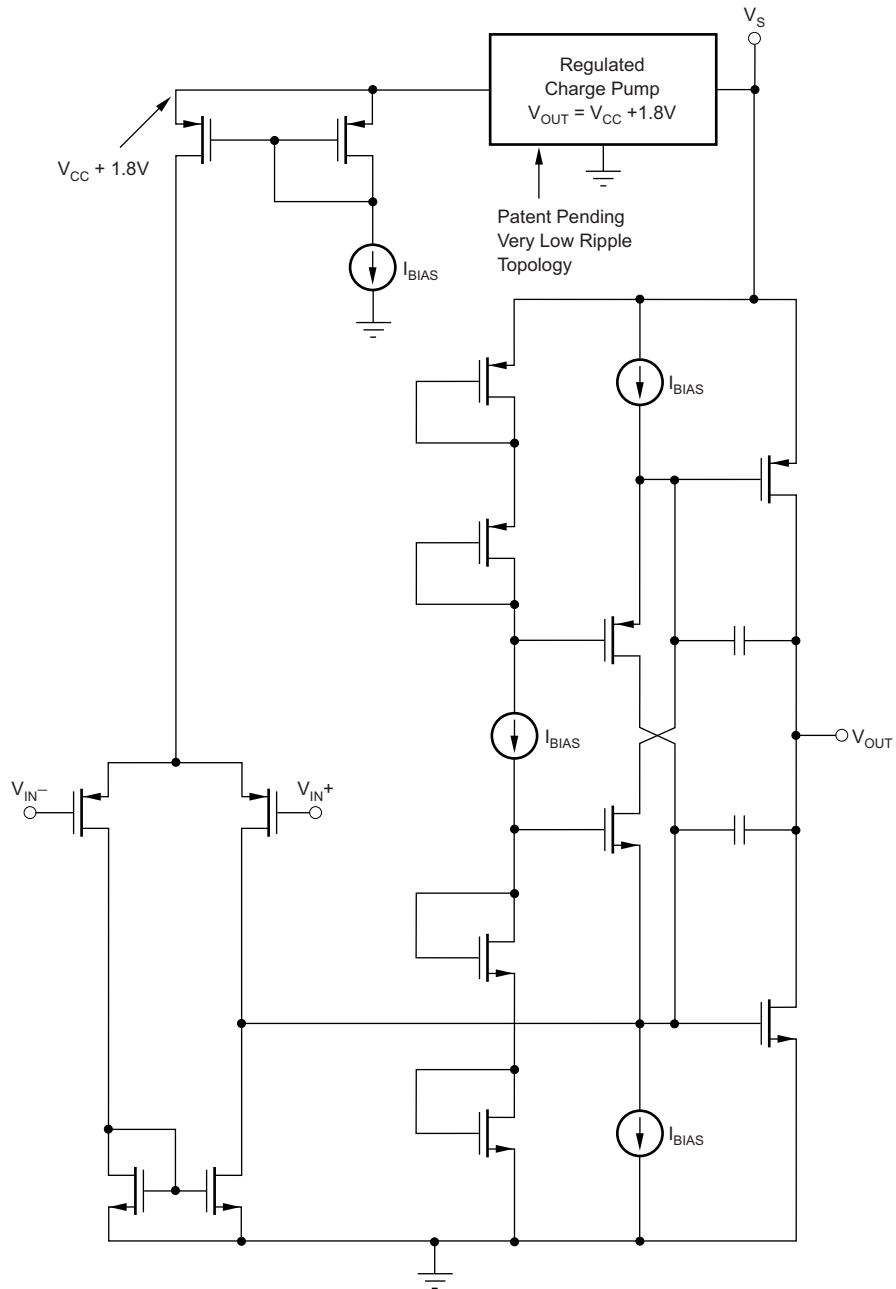

Figure 22. Simplified Schematic.

OPERATING VOLTAGE

The OPA363 and OPA364 series op amp parameters are fully specified from +1.8V to +5.5V. Single 0.1 μ F bypass capacitors should be placed across supply pins and as close to the part as possible. Supply voltages higher than 5.5V (absolute maximum) may cause permanent damage to the amplifier. Many specifications apply from -40°C to $+125^{\circ}\text{C}$. Parameters that vary significantly with operating voltages or temperature are shown in the [Typical Characteristics](#).

ENABLE FUNCTION

The shutdown (enable) function of the OPA363 is referenced to the negative supply voltage of the operational amplifier. A logic level HIGH enables the op amp. A valid logic HIGH is defined as voltage greater than 75% of the positive supply applied to the enable pin. The valid logic HIGH signal can be as much as 5.5V above the negative supply, independent of the positive supply voltage. A valid logic LOW is defined as less than 0.8V above the negative supply pin. If dual or split power supplies are used, care should be taken to ensure logic input signals are properly referred to the negative supply voltage. This pin should be connected to a valid high or low voltage or driven, not left open circuit.

The logic input is a high-impedance CMOS input. Dual op amps are provided separate logic inputs. For battery-operated applications, this feature may be used to greatly reduce the average current and extend battery life. The enable time is 20 μ s; disable time is 1 μ s. When disabled, the output assumes a high-impedance state. This allows the OPA363 to be operated as a “gated” amplifier, or to have its output multiplexed onto a common analog output bus.

CAPACITIVE LOAD

The OPA363 and OPA364 series op amps can drive a wide range of capacitive loads. However, all op amps under certain conditions may become unstable. Op amp configuration, gain, and load value are just a few of the factors to consider when determining stability. An op amp in unity-gain configuration is the most susceptible to the effects of capacitive load. The capacitive load reacts with the output resistance of the op amp to create a pole in the small-signal response, which degrades the phase margin.

In unity gain, the OPA363 and OPA364 series op amps perform well with a pure capacitive load up to approximately 1000pF. The ESR (Equivalent Series Resistance) of the loading capacitor may be sufficient to allow the OPA363 and OPA364 to directly drive very large capacitive loads ($> 1\mu\text{F}$). Increasing gain enhances the amplifier’s ability to drive more capacitance; see [Figure 13](#).

One method of improving capacitive load drive in the unity-gain configuration is to insert a 10 Ω to 20 Ω resistor in series with the output, as shown in [Figure 23](#). This significantly reduces ringing with large capacitive loads. However, if there is a resistive load in parallel with the capacitive load, it creates a voltage divider introducing a dc error at the output and slightly reduces output swing. This error may be insignificant. For instance, with $R_L = 10\text{k}\Omega$ and $R_S = 20\Omega$, there is only about a 0.2% error at the output.

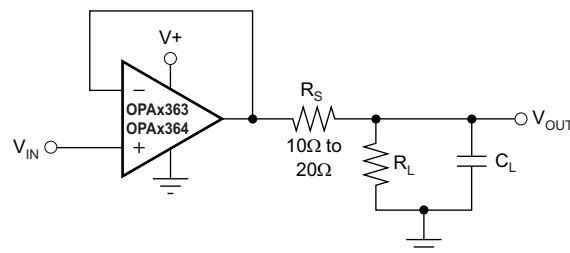

Figure 23. Improving Capacitive Load Drive

INPUT AND ESD PROTECTION

All OPA363 and OPA364 pins are static protected with internal ESD protection diodes tied to the supplies. These diodes will provide overdrive protection if the current is externally limited to 10mA, as stated in the absolute maximum ratings and shown in Figure 24.

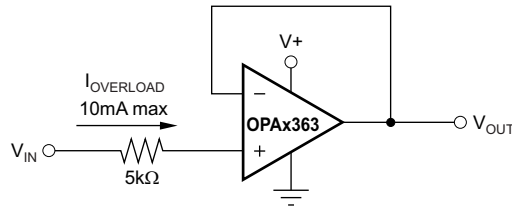

Figure 24. Input Current Protection

ACHIEVING OUTPUT SWING TO THE OP AMP'S NEGATIVE RAIL

Some applications require an accurate output voltage swing from 0V to a positive full-scale voltage. A good single supply op amp may be able to swing within a few mV of single supply ground, but as the output is driven toward 0V, the output stage of the amplifier will prevent the output from reaching the negative supply rail of the amplifier.

The output of the OPA363 or OPA364 can be made to swing to ground, or slightly below, on a single supply power source. To do so requires use of another resistor and an additional, more negative power supply than the op amp's negative supply. A pull-down resistor may be connected between the output and the additional negative supply to pull the output down below the value that the output would otherwise achieve as shown in Figure 25.

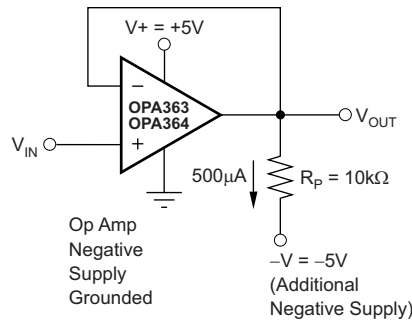

Figure 25. OPA363 and OPA364 Swing to Ground

This technique will not work with all op amps. The output stage of the OPA363 and OPA364 allows the output voltage to be pulled below that of most op amps, if approximately 500μA is maintained through the output stage. To calculate the appropriate value load resistor and negative supply, $R_L = -V/500\mu A$. The OPA363 and OPA364 have been characterized to perform well under the described conditions, maintaining excellent accuracy down to 0V and as low as -10mV. Limiting and nonlinearity occur below -10mV, with linearity returning as the output is again driven above -10mV.

BUFFERED REFERENCE VOLTAGE

Many single-supply applications require a mid-supply reference voltage. The OPA363 and OPA364 offer excellent capacitive load drive capability, and can be configured to provide a 0.9V reference voltage, as can be seen in Figure 26. For appropriate loading considerations, see the CAPACITIVE LOAD section.

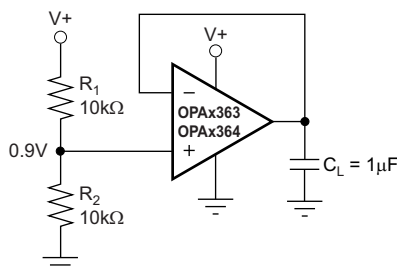

Figure 26. The OPA363 and OPA364 Provide a Stable Reference Voltage

DIRECTLY DRIVING THE ADS8324 AND THE MSP430

The OPA363 and OPA364 series op amps are optimized for driving medium speed (up to 100kHz) sampling A/D converters. However, they also offer excellent performance for higher speed converters. The no crossover input stage of the OPA363 and OPA364 directly drive A/D converters without degradation of differential linearity and THD. They provide an effective means of buffering the A/D converters input capacitance and resulting charge injection while providing signal gain. Figure 27 and Figure 28 show the OPA363 and OPA364 configured to drive the ADS8324 and the 12-bit A/D converter on the MSP430.

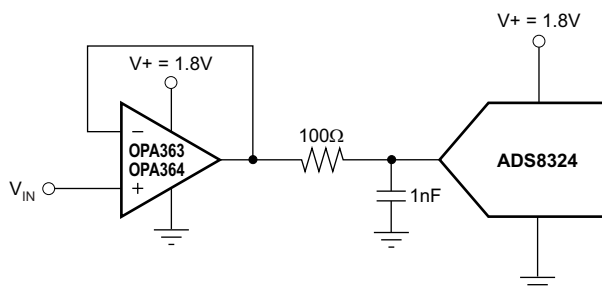

Figure 27. The OPA363 and OPA364 Directly Drive the ADS8324

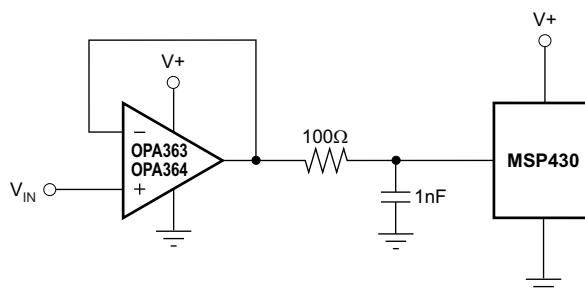

Figure 28. Driving the 12-Bit A/D Converter on the MSP430

AUDIO APPLICATIONS

The OPA363 and OPA364 op amp family has linear offset voltage over the entire input common-mode range. Combined with low-noise, this feature makes the OPA363 and OPA364 suitable for audio applications. Single supply 1.8V operation allows the OPA2363 and OPA2364 to be optimal candidates for dual stereo-headphone drivers and microphone pre-amplifiers in portable stereo equipment, see [Figure 29](#) and [Figure 30](#).

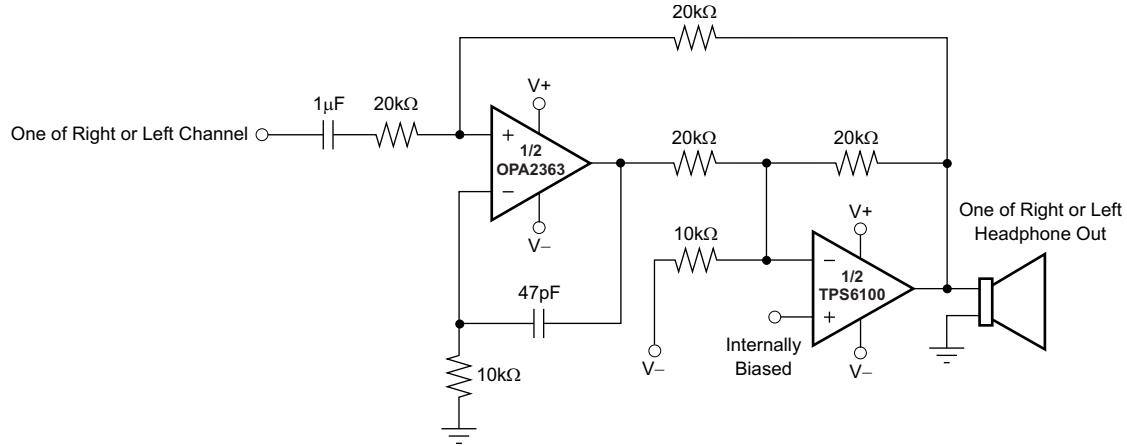

Figure 29. OPA2363 Configured as Half of a Dual Stereo Headphone Driver

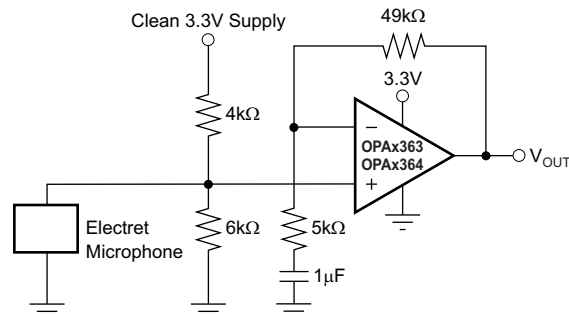

Figure 30. Microphone Preamplifier

ACTIVE FILTERING

Low harmonic distortion and noise specifications plus high gain and slew rate make the OPA363 and OPA364 optimal candidates for active filtering. Figure 31 shows the OPA2363 configured as a low-distortion, 3rd-order GIC (General Immittance Converter) filter. Figure 32 shows the implementation of a Sallen-Key, 3-pole, low-pass Bessel filter.

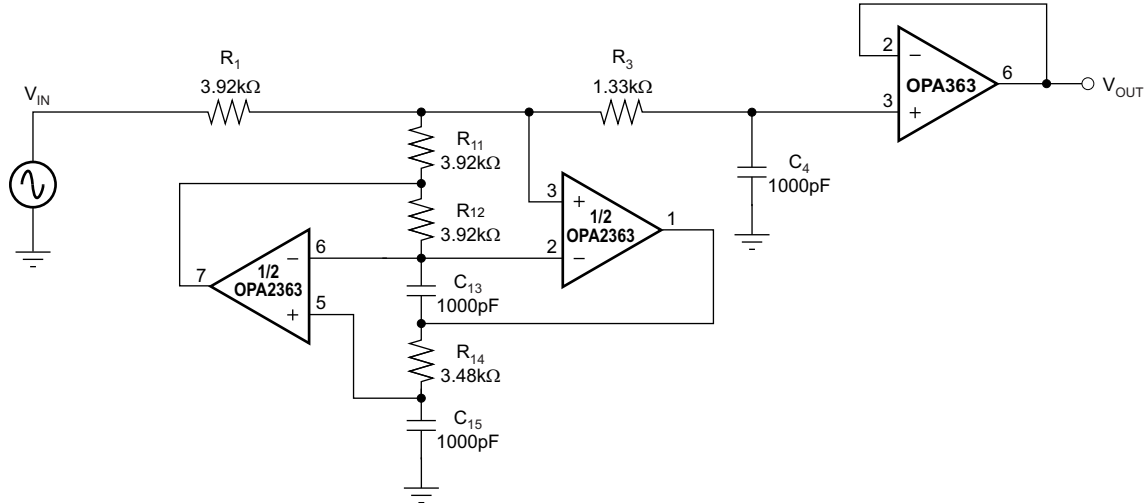

Figure 31. The OPA2363 as a 3rd-Order, 40kHz, Low-Pass GIC Filter

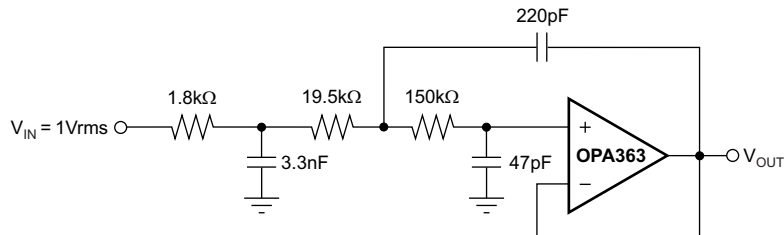

Figure 32. The OPA363 or OPA364 Configured as a 3-Pole, 20kHz, Sallen-Key Filter

REVISION HISTORY

NOTE: Page numbers for previous versions may differ from page numbers in the current version.

Changes from Revision B (February 2003) to Revision C	Page
• Converted data sheet to current format	1
• Added RSV package (UQFN-16) to data sheet	1

PACKAGING INFORMATION

Orderable Device	Status (1)	Package Type	Package Drawing	Pins	Package Qty	Eco Plan (2)	Lead/Ball Finish (6)	MSL Peak Temp (3)	Op Temp (°C)	Device Marking (4/5)	Samples
OPA2363AIDGSR	ACTIVE	VSSOP	DGS	10	2500	Green (RoHS & no Sb/Br)	CU NIPDAUAG	Level-2-260C-1 YEAR	-40 to 125	BHK	Samples
OPA2363AIDGST	ACTIVE	VSSOP	DGS	10	250	Green (RoHS & no Sb/Br)	CU NIPDAUAG	Level-2-260C-1 YEAR	-40 to 125	BHK	Samples
OPA2363AIDGSTG4	ACTIVE	VSSOP	DGS	10	250	Green (RoHS & no Sb/Br)	CU NIPDAUAG	Level-2-260C-1 YEAR	-40 to 125	BHK	Samples
OPA2363AIRSVR	ACTIVE	UQFN	RSV	16	3000	Green (RoHS & no Sb/Br)	CU NIPDAUAG	Level-2-260C-1 YEAR	-40 to 125	SIN	Samples
OPA2363IDGSR	ACTIVE	VSSOP	DGS	10	2500	Green (RoHS & no Sb/Br)	CU NIPDAUAG	Level-2-260C-1 YEAR	-40 to 125	BHK	Samples
OPA2363IDGST	ACTIVE	VSSOP	DGS	10	250	Green (RoHS & no Sb/Br)	CU NIPDAUAG	Level-2-260C-1 YEAR	-40 to 125	BHK	Samples
OPA2363IDGSTG4	ACTIVE	VSSOP	DGS	10	250	Green (RoHS & no Sb/Br)	CU NIPDAUAG	Level-2-260C-1 YEAR	-40 to 125	BHK	Samples
OPA2364AID	ACTIVE	SOIC	D	8	75	Green (RoHS & no Sb/Br)	CU NIPDAU	Level-2-260C-1 YEAR	-40 to 125	OPA 2364 A	Samples
OPA2364AIDG4	ACTIVE	SOIC	D	8	75	Green (RoHS & no Sb/Br)	CU NIPDAU	Level-2-260C-1 YEAR	-40 to 125	OPA 2364 A	Samples
OPA2364AIDGKR	ACTIVE	VSSOP	DGK	8	2500	Green (RoHS & no Sb/Br)	CU NIPDAUAG	Level-2-260C-1 YEAR	-40 to 125	BHL	Samples
OPA2364AIDGKRG4	ACTIVE	VSSOP	DGK	8	2500	Green (RoHS & no Sb/Br)	CU NIPDAUAG	Level-2-260C-1 YEAR	-40 to 125	BHL	Samples
OPA2364AIDGKT	ACTIVE	VSSOP	DGK	8	250	Green (RoHS & no Sb/Br)	CU NIPDAUAG	Level-2-260C-1 YEAR	-40 to 125	BHL	Samples
OPA2364AIDGKTG4	ACTIVE	VSSOP	DGK	8	250	Green (RoHS & no Sb/Br)	CU NIPDAUAG	Level-2-260C-1 YEAR	-40 to 125	BHL	Samples
OPA2364AIDR	ACTIVE	SOIC	D	8	2500	Green (RoHS & no Sb/Br)	CU NIPDAU	Level-2-260C-1 YEAR	-40 to 125	OPA 2364 A	Samples
OPA2364AIDRG4	ACTIVE	SOIC	D	8	2500	Green (RoHS & no Sb/Br)	CU NIPDAU	Level-2-260C-1 YEAR	-40 to 125	OPA 2364 A	Samples

Orderable Device	Status (1)	Package Type	Package Drawing	Pins	Package Qty	Eco Plan (2)	Lead/Ball Finish (6)	MSL Peak Temp (3)	Op Temp (°C)	Device Marking (4/5)	Samples
OPA2364ID	ACTIVE	SOIC	D	8	75	Green (RoHS & no Sb/Br)	CU NIPDAU	Level-2-260C-1 YEAR	-40 to 125	OPA 2364	Samples
OPA2364IDG4	ACTIVE	SOIC	D	8		TBD	Call TI	Call TI	-40 to 125		Samples
OPA2364IDGKR	ACTIVE	VSSOP	DGK	8	2500	Green (RoHS & no Sb/Br)	CU NIPDAUAG	Level-2-260C-1 YEAR	-40 to 125	BHL	Samples
OPA2364IDGKRG4	ACTIVE	VSSOP	DGK	8	2500	Green (RoHS & no Sb/Br)	CU NIPDAUAG	Level-2-260C-1 YEAR	-40 to 125	BHL	Samples
OPA2364IDGKT	ACTIVE	VSSOP	DGK	8	250	Green (RoHS & no Sb/Br)	CU NIPDAUAG	Level-2-260C-1 YEAR	-40 to 125	BHL	Samples
OPA2364IDGKTG4	ACTIVE	VSSOP	DGK	8	250	Green (RoHS & no Sb/Br)	CU NIPDAUAG	Level-2-260C-1 YEAR	-40 to 125	BHL	Samples
OPA2364IDR	ACTIVE	SOIC	D	8	2500	Green (RoHS & no Sb/Br)	CU NIPDAU	Level-2-260C-1 YEAR	-40 to 125	OPA 2364	Samples
OPA2364IDRG4	ACTIVE	SOIC	D	8	2500	Green (RoHS & no Sb/Br)	CU NIPDAU	Level-2-260C-1 YEAR	-40 to 125	OPA 2364	Samples
OPA363AID	ACTIVE	SOIC	D	8	75	Green (RoHS & no Sb/Br)	CU NIPDAU	Level-2-260C-1 YEAR	-40 to 125	OPA 363 A	Samples
OPA363AIDBVR	ACTIVE	SOT-23	DBV	6	3000	Green (RoHS & no Sb/Br)	CU NIPDAU	Level-2-260C-1 YEAR	-40 to 125	A40	Samples
OPA363AIDBVRG4	ACTIVE	SOT-23	DBV	6	3000	Green (RoHS & no Sb/Br)	CU NIPDAU	Level-2-260C-1 YEAR	-40 to 125	A40	Samples
OPA363AIDBVT	ACTIVE	SOT-23	DBV	6	250	Green (RoHS & no Sb/Br)	CU NIPDAU	Level-2-260C-1 YEAR	-40 to 125	A40	Samples
OPA363AIDBVTG4	ACTIVE	SOT-23	DBV	6	250	Green (RoHS & no Sb/Br)	CU NIPDAU	Level-2-260C-1 YEAR	-40 to 125	A40	Samples
OPA363ID	ACTIVE	SOIC	D	8	75	Green (RoHS & no Sb/Br)	CU NIPDAU	Level-2-260C-1 YEAR	-40 to 125	OPA 363	Samples
OPA363IDBVR	ACTIVE	SOT-23	DBV	6	3000	Green (RoHS & no Sb/Br)	CU NIPDAU	Level-2-260C-1 YEAR	-40 to 125	A40	Samples
OPA363IDBVRG4	ACTIVE	SOT-23	DBV	6	3000	Green (RoHS & no Sb/Br)	CU NIPDAU	Level-2-260C-1 YEAR	-40 to 125	A40	Samples
OPA363IDBVT	ACTIVE	SOT-23	DBV	6	250	Green (RoHS & no Sb/Br)	CU NIPDAU	Level-2-260C-1 YEAR	-40 to 125	A40	Samples
OPA363IDBVTG4	ACTIVE	SOT-23	DBV	6	250	Green (RoHS & no Sb/Br)	CU NIPDAU	Level-2-260C-1 YEAR	-40 to 125	A40	Samples

Orderable Device	Status (1)	Package Type	Package Drawing	Pins	Package Qty	Eco Plan (2)	Lead/Ball Finish (6)	MSL Peak Temp (3)	Op Temp (°C)	Device Marking (4/5)	Samples
OPA363IDG4	ACTIVE	SOIC	D	8	75	Green (RoHS & no Sb/Br)	CU NIPDAU	Level-2-260C-1 YEAR	-40 to 125	OPA 363	Samples
OPA364AID	ACTIVE	SOIC	D	8	75	Green (RoHS & no Sb/Br)	CU NIPDAU	Level-2-260C-1 YEAR	-40 to 125	OPA 364 A	Samples
OPA364AIDBVR	ACTIVE	SOT-23	DBV	5	3000	Green (RoHS & no Sb/Br)	CU NIPDAU	Level-2-260C-1 YEAR	-40 to 125	A41	Samples
OPA364AIDBVRG4	ACTIVE	SOT-23	DBV	5	3000	Green (RoHS & no Sb/Br)	CU NIPDAU	Level-2-260C-1 YEAR	-40 to 125	A41	Samples
OPA364AIDBVT	ACTIVE	SOT-23	DBV	5	250	Green (RoHS & no Sb/Br)	CU NIPDAU	Level-2-260C-1 YEAR	-40 to 125	A41	Samples
OPA364AIDBVTG4	ACTIVE	SOT-23	DBV	5	250	Green (RoHS & no Sb/Br)	CU NIPDAU	Level-2-260C-1 YEAR	-40 to 125	A41	Samples
OPA364AIDR	ACTIVE	SOIC	D	8	2500	Green (RoHS & no Sb/Br)	CU NIPDAU	Level-2-260C-1 YEAR	-40 to 125	OPA 364 A	Samples
OPA364ID	ACTIVE	SOIC	D	8	75	Green (RoHS & no Sb/Br)	CU NIPDAU	Level-2-260C-1 YEAR	-40 to 125	OPA 364	Samples
OPA364IDBVR	ACTIVE	SOT-23	DBV	5	3000	Green (RoHS & no Sb/Br)	CU NIPDAU	Level-2-260C-1 YEAR	-40 to 125	A41	Samples
OPA364IDBVRG4	ACTIVE	SOT-23	DBV	5	3000	Green (RoHS & no Sb/Br)	CU NIPDAU	Level-2-260C-1 YEAR	-40 to 125	A41	Samples
OPA364IDBVT	ACTIVE	SOT-23	DBV	5	250	Green (RoHS & no Sb/Br)	CU NIPDAU	Level-2-260C-1 YEAR	-40 to 125	A41	Samples
OPA364IDBVTG4	ACTIVE	SOT-23	DBV	5	250	Green (RoHS & no Sb/Br)	CU NIPDAU	Level-2-260C-1 YEAR	-40 to 125	A41	Samples
OPA364IDG4	ACTIVE	SOIC	D	8	75	Green (RoHS & no Sb/Br)	CU NIPDAU	Level-2-260C-1 YEAR	-40 to 125	OPA 364	Samples
OPA364IDR	ACTIVE	SOIC	D	8	2500	Green (RoHS & no Sb/Br)	CU NIPDAU	Level-2-260C-1 YEAR	-40 to 125	OPA 364	Samples
OPA364IDRG4	ACTIVE	SOIC	D	8	2500	Green (RoHS & no Sb/Br)	CU NIPDAU	Level-2-260C-1 YEAR	-40 to 125	OPA 364	Samples
OPA4364AID	ACTIVE	SOIC	D	14	50	Green (RoHS & no Sb/Br)	CU NIPDAU	Level-2-260C-1 YEAR	-40 to 125	OPA4364A	Samples
OPA4364AIDG4	ACTIVE	SOIC	D	14	50	Green (RoHS & no Sb/Br)	CU NIPDAU	Level-2-260C-1 YEAR	-40 to 125	OPA4364A	Samples

Orderable Device	Status (1)	Package Type	Package Drawing	Pins	Package Qty	Eco Plan (2)	Lead/Ball Finish (6)	MSL Peak Temp (3)	Op Temp (°C)	Device Marking (4/5)	Samples
OPA4364AIDR	ACTIVE	SOIC	D	14	2500	Green (RoHS & no Sb/Br)	CU NIPDAU	Level-2-260C-1 YEAR	-40 to 125	OPA4364A	Samples
OPA4364AIDRG4	ACTIVE	SOIC	D	14	2500	Green (RoHS & no Sb/Br)	CU NIPDAU	Level-2-260C-1 YEAR	-40 to 125	OPA4364A	Samples
OPA4364AIPWR	ACTIVE	TSSOP	PW	14	2500	Green (RoHS & no Sb/Br)	CU NIPDAU	Level-2-260C-1 YEAR	-40 to 125	OPA 4364A	Samples
OPA4364AIPWRG4	ACTIVE	TSSOP	PW	14	2500	Green (RoHS & no Sb/Br)	CU NIPDAU	Level-2-260C-1 YEAR	-40 to 125	OPA 4364A	Samples
OPA4364AIPWT	ACTIVE	TSSOP	PW	14	250	Green (RoHS & no Sb/Br)	CU NIPDAU	Level-2-260C-1 YEAR	-40 to 125	OPA 4364A	Samples
OPA4364AIPWTG4	ACTIVE	TSSOP	PW	14	250	Green (RoHS & no Sb/Br)	CU NIPDAU	Level-2-260C-1 YEAR	-40 to 125	OPA 4364A	Samples

(1) The marketing status values are defined as follows:

ACTIVE: Product device recommended for new designs.

LIFEBUY: TI has announced that the device will be discontinued, and a lifetime-buy period is in effect.

NRND: Not recommended for new designs. Device is in production to support existing customers, but TI does not recommend using this part in a new design.

PREVIEW: Device has been announced but is not in production. Samples may or may not be available.

OBSOLETE: TI has discontinued the production of the device.

(2) Eco Plan - The planned eco-friendly classification: Pb-Free (RoHS), Pb-Free (RoHS Exempt), or Green (RoHS & no Sb/Br) - please check <http://www.ti.com/productcontent> for the latest availability information and additional product content details.

TBD: The Pb-Free/Green conversion plan has not been defined.

Pb-Free (RoHS): TI's terms "Lead-Free" or "Pb-Free" mean semiconductor products that are compatible with the current RoHS requirements for all 6 substances, including the requirement that lead not exceed 0.1% by weight in homogeneous materials. Where designed to be soldered at high temperatures, TI Pb-Free products are suitable for use in specified lead-free processes.

Pb-Free (RoHS Exempt): This component has a RoHS exemption for either 1) lead-based flip-chip solder bumps used between the die and package, or 2) lead-based die adhesive used between the die and leadframe. The component is otherwise considered Pb-Free (RoHS compatible) as defined above.

Green (RoHS & no Sb/Br): TI defines "Green" to mean Pb-Free (RoHS compatible), and free of Bromine (Br) and Antimony (Sb) based flame retardants (Br or Sb do not exceed 0.1% by weight in homogeneous material)

(3) MSL, Peak Temp. - The Moisture Sensitivity Level rating according to the JEDEC industry standard classifications, and peak solder temperature.

(4) There may be additional marking, which relates to the logo, the lot trace code information, or the environmental category on the device.

(5) Multiple Device Markings will be inside parentheses. Only one Device Marking contained in parentheses and separated by a "-" will appear on a device. If a line is indented then it is a continuation of the previous line and the two combined represent the entire Device Marking for that device.

⁽⁶⁾ Lead/Ball Finish - Orderable Devices may have multiple material finish options. Finish options are separated by a vertical ruled line. Lead/Ball Finish values may wrap to two lines if the finish value exceeds the maximum column width.

Important Information and Disclaimer:The information provided on this page represents TI's knowledge and belief as of the date that it is provided. TI bases its knowledge and belief on information provided by third parties, and makes no representation or warranty as to the accuracy of such information. Efforts are underway to better integrate information from third parties. TI has taken and continues to take reasonable steps to provide representative and accurate information but may not have conducted destructive testing or chemical analysis on incoming materials and chemicals. TI and TI suppliers consider certain information to be proprietary, and thus CAS numbers and other limited information may not be available for release.

In no event shall TI's liability arising out of such information exceed the total purchase price of the TI part(s) at issue in this document sold by TI to Customer on an annual basis.

OTHER QUALIFIED VERSIONS OF OPA4364 :

- Automotive: [OPA4364-Q1](#)

NOTE: Qualified Version Definitions:

- Automotive - Q100 devices qualified for high-reliability automotive applications targeting zero defects

TAPE AND REEL INFORMATION



QUADRANT ASSIGNMENTS FOR PIN 1 ORIENTATION IN TAPE



*All dimensions are nominal

Device	Package Type	Package Drawing	Pins	SPQ	Reel Diameter (mm)	Reel Width W1 (mm)	A0 (mm)	B0 (mm)	K0 (mm)	P1 (mm)	W (mm)	Pin1 Quadrant
OPA2363AIDGSR	VSSOP	DGS	10	2500	330.0	12.4	5.3	3.4	1.4	8.0	12.0	Q1
OPA2363AIDGST	VSSOP	DGS	10	250	180.0	12.4	5.3	3.4	1.4	8.0	12.0	Q1
OPA2363AIRSVR	UQFN	RSV	16	3000	177.8	12.4	2.0	2.8	0.7	4.0	12.0	Q1
OPA2363IDGSR	VSSOP	DGS	10	2500	330.0	12.4	5.3	3.4	1.4	8.0	12.0	Q1
OPA2363IDGST	VSSOP	DGS	10	250	180.0	12.4	5.3	3.4	1.4	8.0	12.0	Q1
OPA2364AIDGKR	VSSOP	DGK	8	2500	330.0	12.4	5.3	3.4	1.4	8.0	12.0	Q1
OPA2364AIDGKT	VSSOP	DGK	8	250	180.0	12.4	5.3	3.4	1.4	8.0	12.0	Q1
OPA2364AIDR	SOIC	D	8	2500	330.0	12.4	6.4	5.2	2.1	8.0	12.0	Q1
OPA2364IDGKR	VSSOP	DGK	8	2500	330.0	12.4	5.3	3.4	1.4	8.0	12.0	Q1
OPA2364IDGKT	VSSOP	DGK	8	250	180.0	12.4	5.3	3.4	1.4	8.0	12.0	Q1
OPA2364IDR	SOIC	D	8	2500	330.0	12.4	6.4	5.2	2.1	8.0	12.0	Q1
OPA363AIDBVR	SOT-23	DBV	6	3000	178.0	9.0	3.23	3.17	1.37	4.0	8.0	Q3
OPA363AIDBVT	SOT-23	DBV	6	250	178.0	9.0	3.23	3.17	1.37	4.0	8.0	Q3
OPA363IDBVR	SOT-23	DBV	6	3000	178.0	9.0	3.23	3.17	1.37	4.0	8.0	Q3
OPA363IDBVT	SOT-23	DBV	6	250	178.0	9.0	3.23	3.17	1.37	4.0	8.0	Q3
OPA364AIDBVR	SOT-23	DBV	5	3000	180.0	8.4	3.2	3.1	1.39	4.0	8.0	Q3
OPA364AIDBVT	SOT-23	DBV	5	250	180.0	8.4	3.2	3.1	1.39	4.0	8.0	Q3
OPA364AIDR	SOIC	D	8	2500	330.0	12.4	6.4	5.2	2.1	8.0	12.0	Q1

Device	Package Type	Package Drawing	Pins	SPQ	Reel Diameter (mm)	Reel Width W1 (mm)	A0 (mm)	B0 (mm)	K0 (mm)	P1 (mm)	W (mm)	Pin1 Quadrant
OPA364IDBVR	SOT-23	DBV	5	3000	180.0	8.4	3.2	3.1	1.39	4.0	8.0	Q3
OPA364IDBVT	SOT-23	DBV	5	250	180.0	8.4	3.2	3.1	1.39	4.0	8.0	Q3
OPA364IDR	SOIC	D	8	2500	330.0	12.4	6.4	5.2	2.1	8.0	12.0	Q1
OPA4364AIDR	SOIC	D	14	2500	330.0	16.4	6.5	9.0	2.1	8.0	16.0	Q1
OPA4364AIPWR	TSSOP	PW	14	2500	330.0	12.4	6.9	5.6	1.6	8.0	12.0	Q1
OPA4364AIPWT	TSSOP	PW	14	250	180.0	12.4	6.9	5.6	1.6	8.0	12.0	Q1

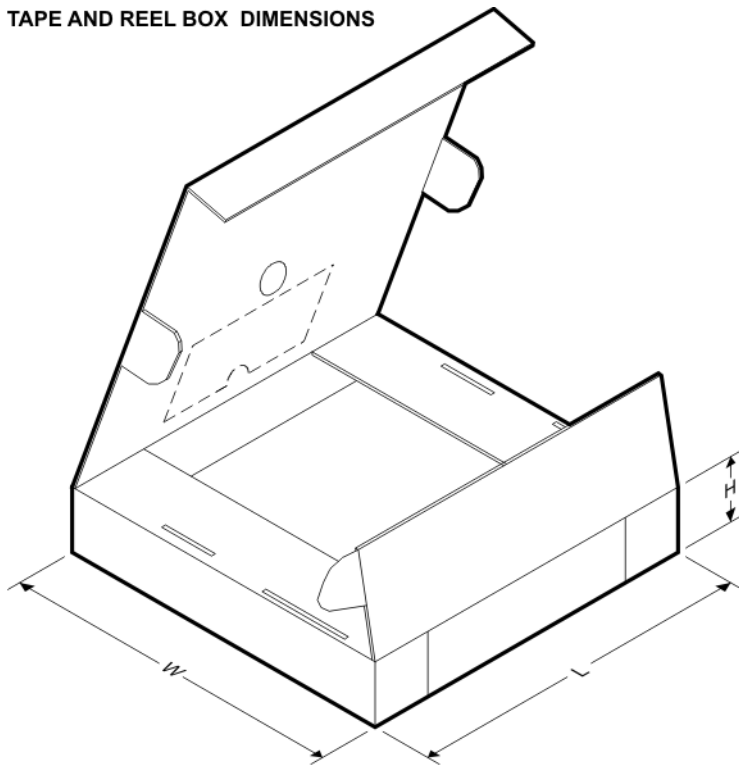
TAPE AND REEL BOX DIMENSIONS

*All dimensions are nominal

Device	Package Type	Package Drawing	Pins	SPQ	Length (mm)	Width (mm)	Height (mm)
OPA2363AIDGSR	VSSOP	DGS	10	2500	367.0	367.0	35.0
OPA2363AIDGST	VSSOP	DGS	10	250	210.0	185.0	35.0
OPA2363AIRSVR	UQFN	RSV	16	3000	223.0	270.0	35.0
OPA2363IDGSR	VSSOP	DGS	10	2500	367.0	367.0	35.0
OPA2363IDGST	VSSOP	DGS	10	250	210.0	185.0	35.0
OPA2364AIDGKR	VSSOP	DGK	8	2500	367.0	367.0	35.0
OPA2364AIDGKT	VSSOP	DGK	8	250	210.0	185.0	35.0
OPA2364AIDR	SOIC	D	8	2500	367.0	367.0	35.0
OPA2364IDGKR	VSSOP	DGK	8	2500	367.0	367.0	35.0
OPA2364IDGKT	VSSOP	DGK	8	250	210.0	185.0	35.0
OPA2364IDR	SOIC	D	8	2500	367.0	367.0	35.0

Device	Package Type	Package Drawing	Pins	SPQ	Length (mm)	Width (mm)	Height (mm)
OPA363AIDBVR	SOT-23	DBV	6	3000	565.0	140.0	75.0
OPA363AIDBVT	SOT-23	DBV	6	250	565.0	140.0	75.0
OPA363IDBVR	SOT-23	DBV	6	3000	565.0	140.0	75.0
OPA363IDBVT	SOT-23	DBV	6	250	565.0	140.0	75.0
OPA364AIDBVR	SOT-23	DBV	5	3000	210.0	185.0	35.0
OPA364AIDBVT	SOT-23	DBV	5	250	210.0	185.0	35.0
OPA364AIDR	SOIC	D	8	2500	367.0	367.0	35.0
OPA364IDBVR	SOT-23	DBV	5	3000	210.0	185.0	35.0
OPA364IDBVT	SOT-23	DBV	5	250	210.0	185.0	35.0
OPA364IDR	SOIC	D	8	2500	367.0	367.0	35.0
OPA4364AIDR	SOIC	D	14	2500	367.0	367.0	38.0
OPA4364AIPWR	TSSOP	PW	14	2500	367.0	367.0	35.0
OPA4364AIPWT	TSSOP	PW	14	250	210.0	185.0	35.0

DBV (R-PDSO-G5)

PLASTIC SMALL-OUTLINE PACKAGE

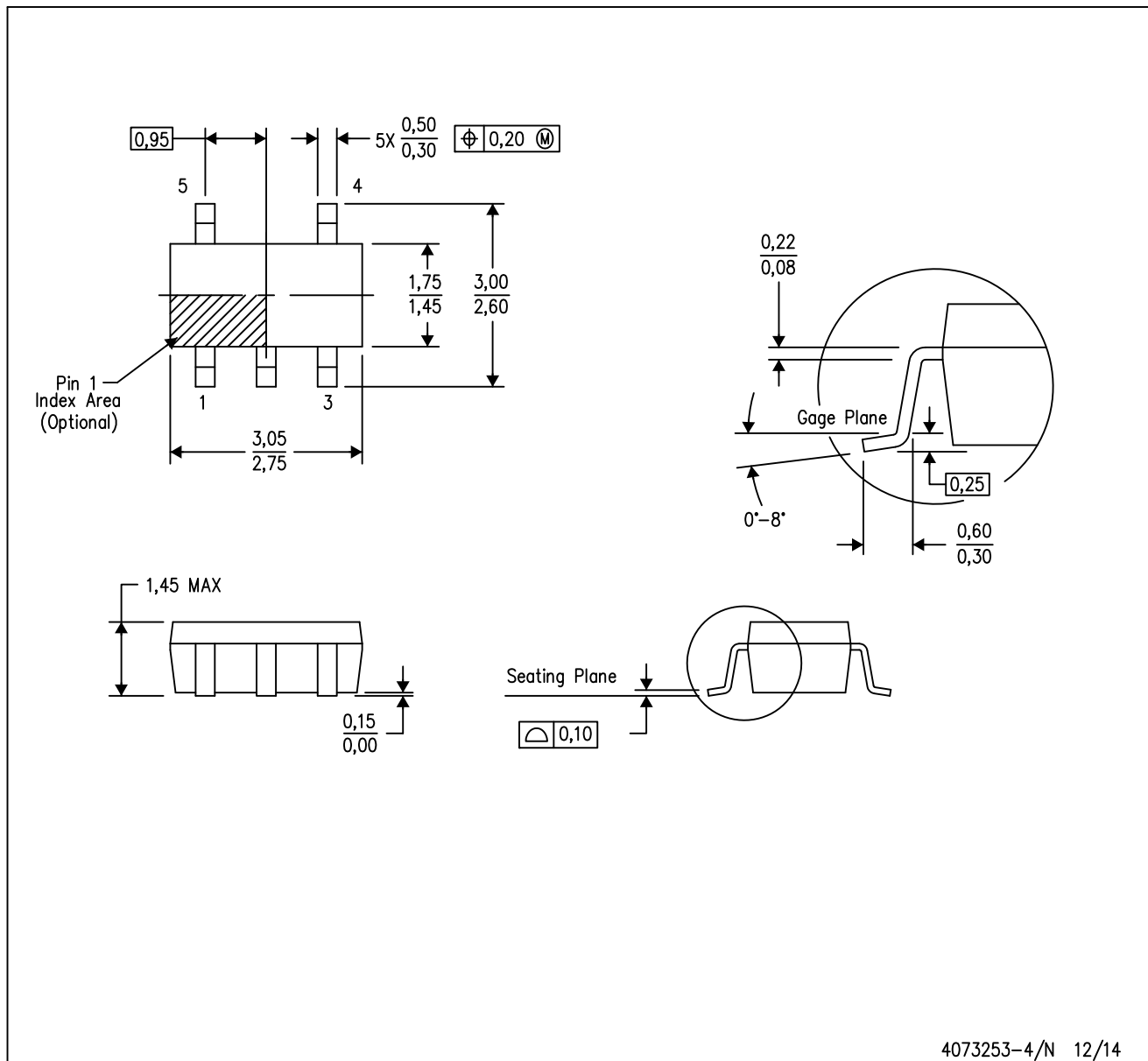

- NOTES:
- A. All linear dimensions are in millimeters.
 - B. This drawing is subject to change without notice.
 - C. Body dimensions do not include mold flash or protrusion. Mold flash and protrusion shall not exceed 0.15 per side.
 - D. Falls within JEDEC MO-178 Variation AA.

DBV (R-PDSO-G5)

PLASTIC SMALL OUTLINE

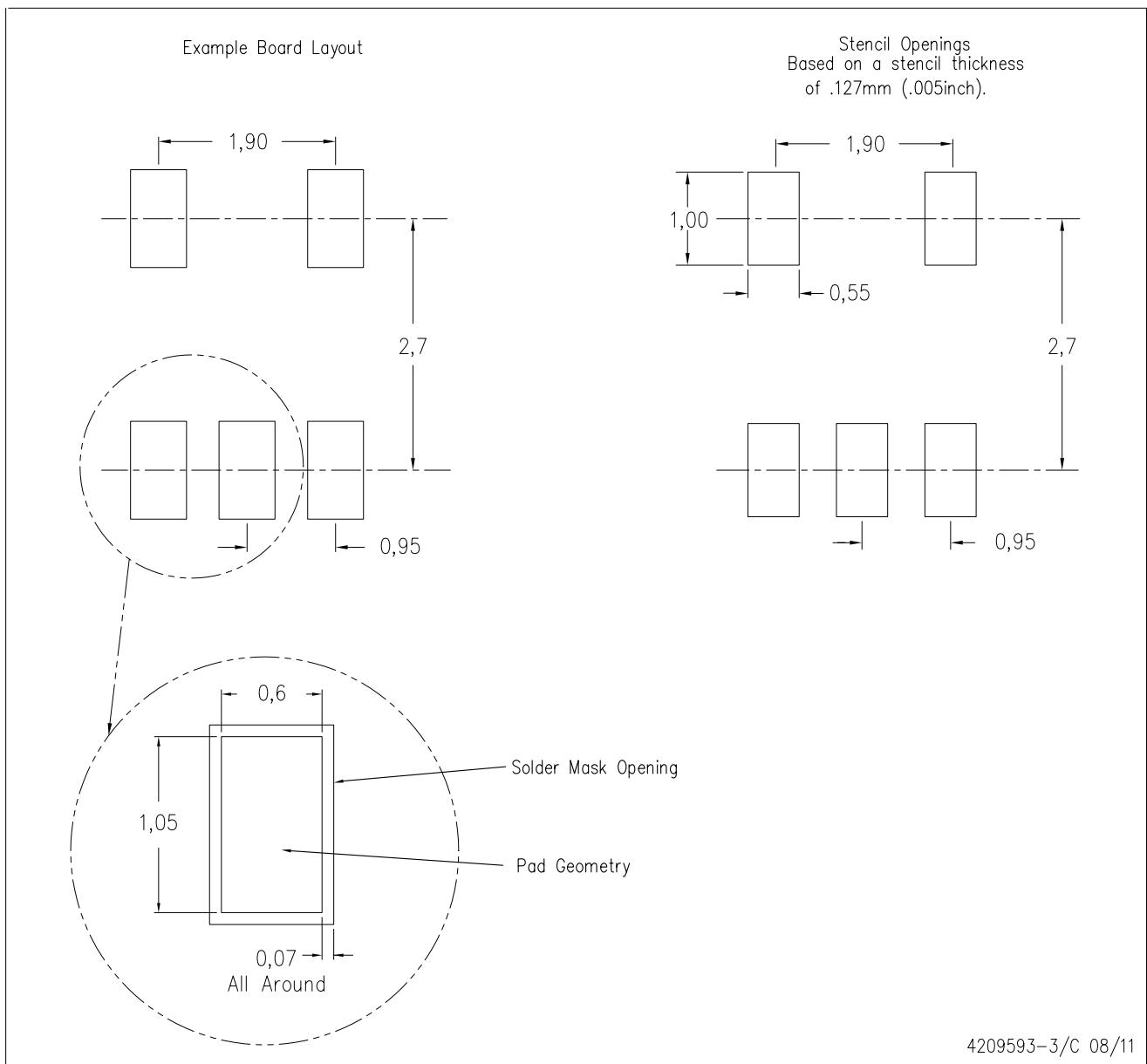

- NOTES:
- A. All linear dimensions are in millimeters.
 - B. This drawing is subject to change without notice.
 - C. Customers should place a note on the circuit board fabrication drawing not to alter the center solder mask defined pad.
 - D. Publication IPC-7351 is recommended for alternate designs.
 - E. Laser cutting apertures with trapezoidal walls and also rounding corners will offer better paste release. Customers should contact their board assembly site for stencil design recommendations. Example stencil design based on a 50% volumetric metal load solder paste. Refer to IPC-7525 for other stencil recommendations.

MECHANICAL DATA

DBV (R-PDSO-G6)

PLASTIC SMALL-OUTLINE PACKAGE

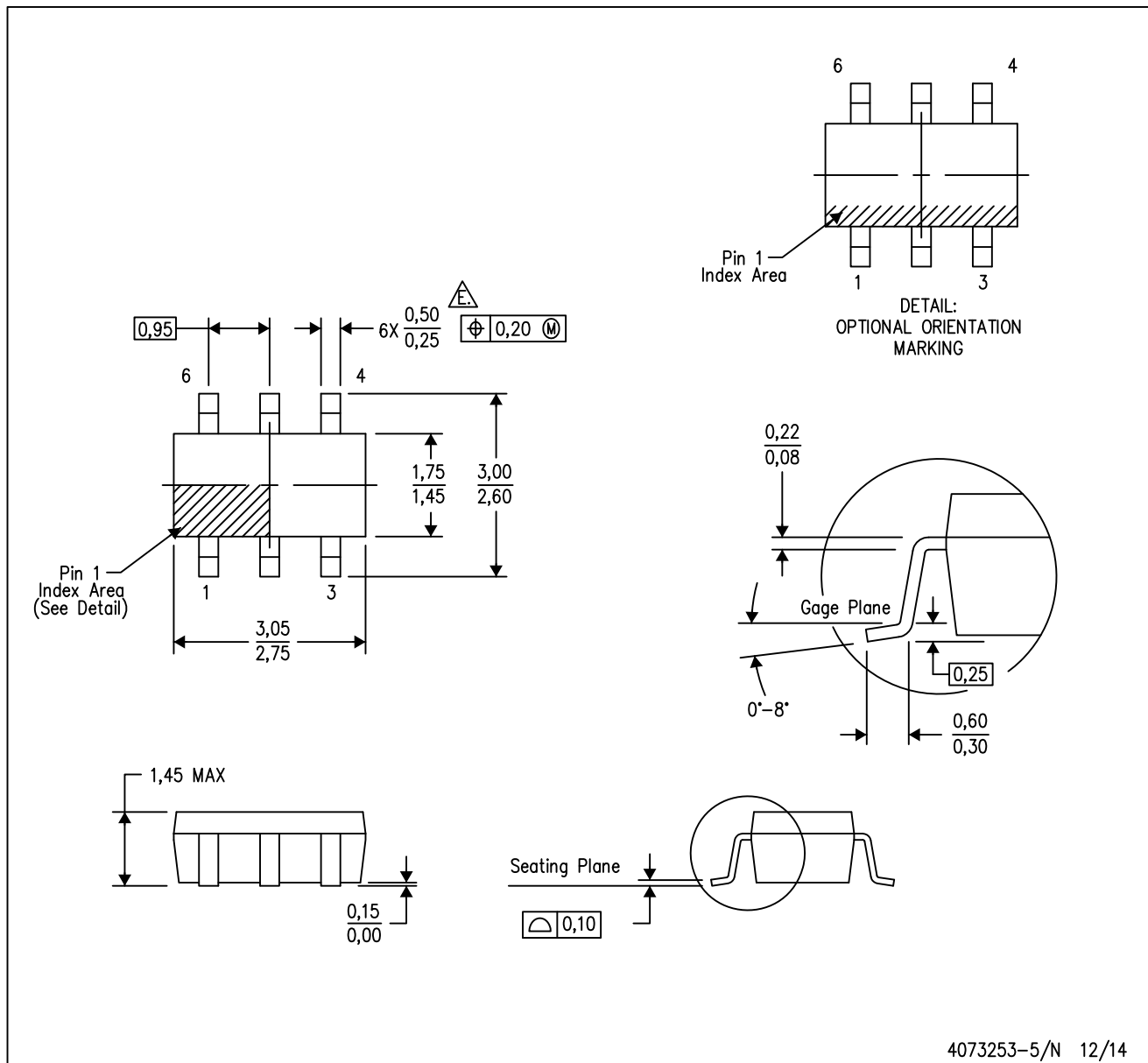

- NOTES:
- A. All linear dimensions are in millimeters.
 - B. This drawing is subject to change without notice.
 - C. Body dimensions do not include mold flash or protrusion. Mold flash and protrusion shall not exceed 0.15 per side.
 - D. Leads 1,2,3 may be wider than leads 4,5,6 for package orientation.
- Falls within JEDEC MO-178 Variation AB, except minimum lead width.

DBV (R-PDSO-G6)

PLASTIC SMALL OUTLINE

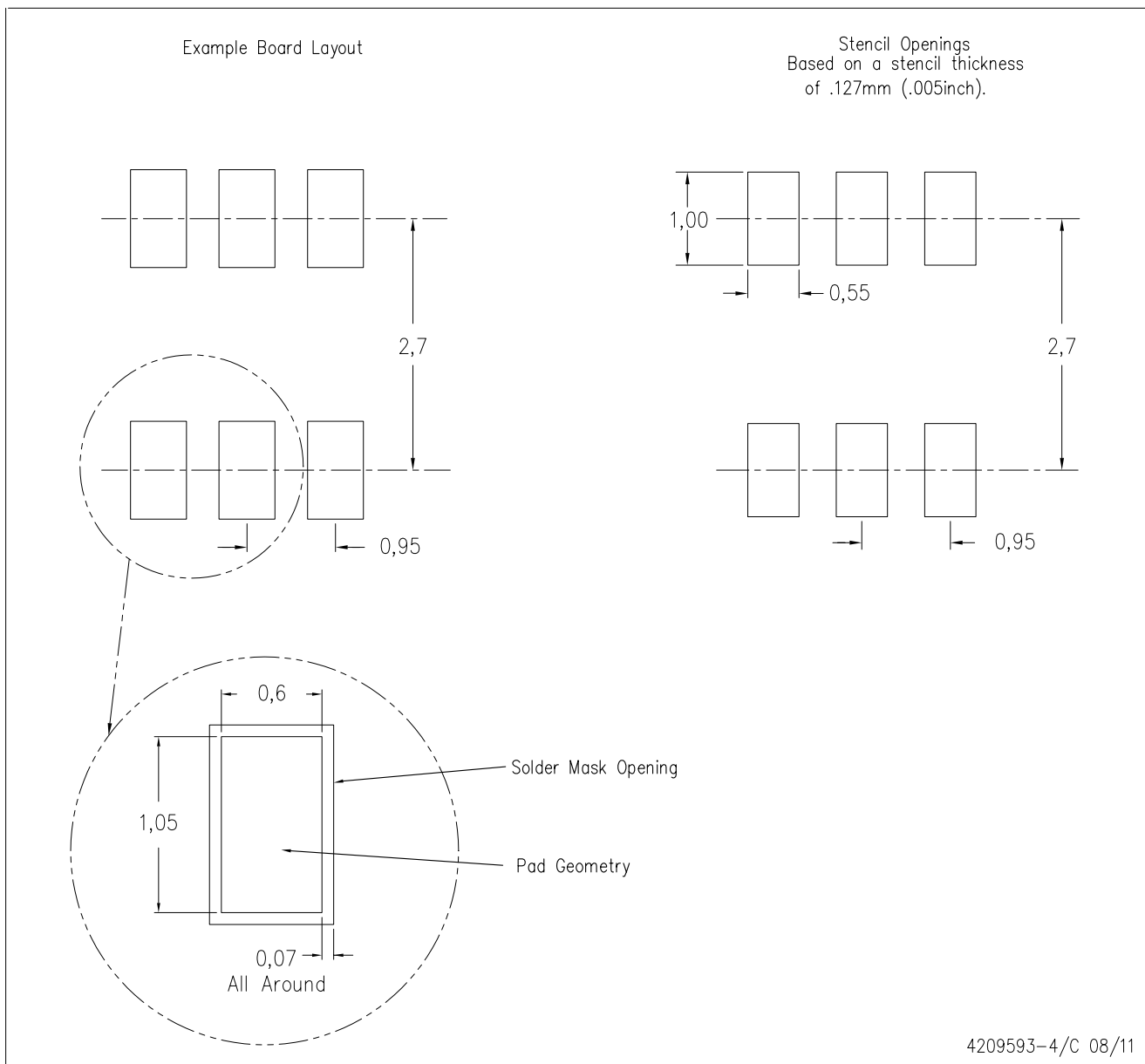

4209593-4/C 08/11

- NOTES:
- A. All linear dimensions are in millimeters.
 - B. This drawing is subject to change without notice.
 - C. Customers should place a note on the circuit board fabrication drawing not to alter the center solder mask defined pad.
 - D. Publication IPC-7351 is recommended for alternate designs.
 - E. Laser cutting apertures with trapezoidal walls and also rounding corners will offer better paste release. Customers should contact their board assembly site for stencil design recommendations. Example stencil design based on a 50% volumetric metal load solder paste. Refer to IPC-7525 for other stencil recommendations.



- NOTES:
- A. All linear dimensions are in millimeters.
 - B. This drawing is subject to change without notice.
 - C. Publication IPC-7351 is recommended for alternate designs.
 - D. Laser cutting apertures with trapezoidal walls and also rounding corners will offer better paste release. Customers should contact their board assembly site for stencil design recommendations. Refer to IPC-7525 for other stencil recommendations.
 - E. Customers should contact their board fabrication site for solder mask tolerances between and around signal pads.

DGS (S-PDSO-G10)

PLASTIC SMALL-OUTLINE PACKAGE

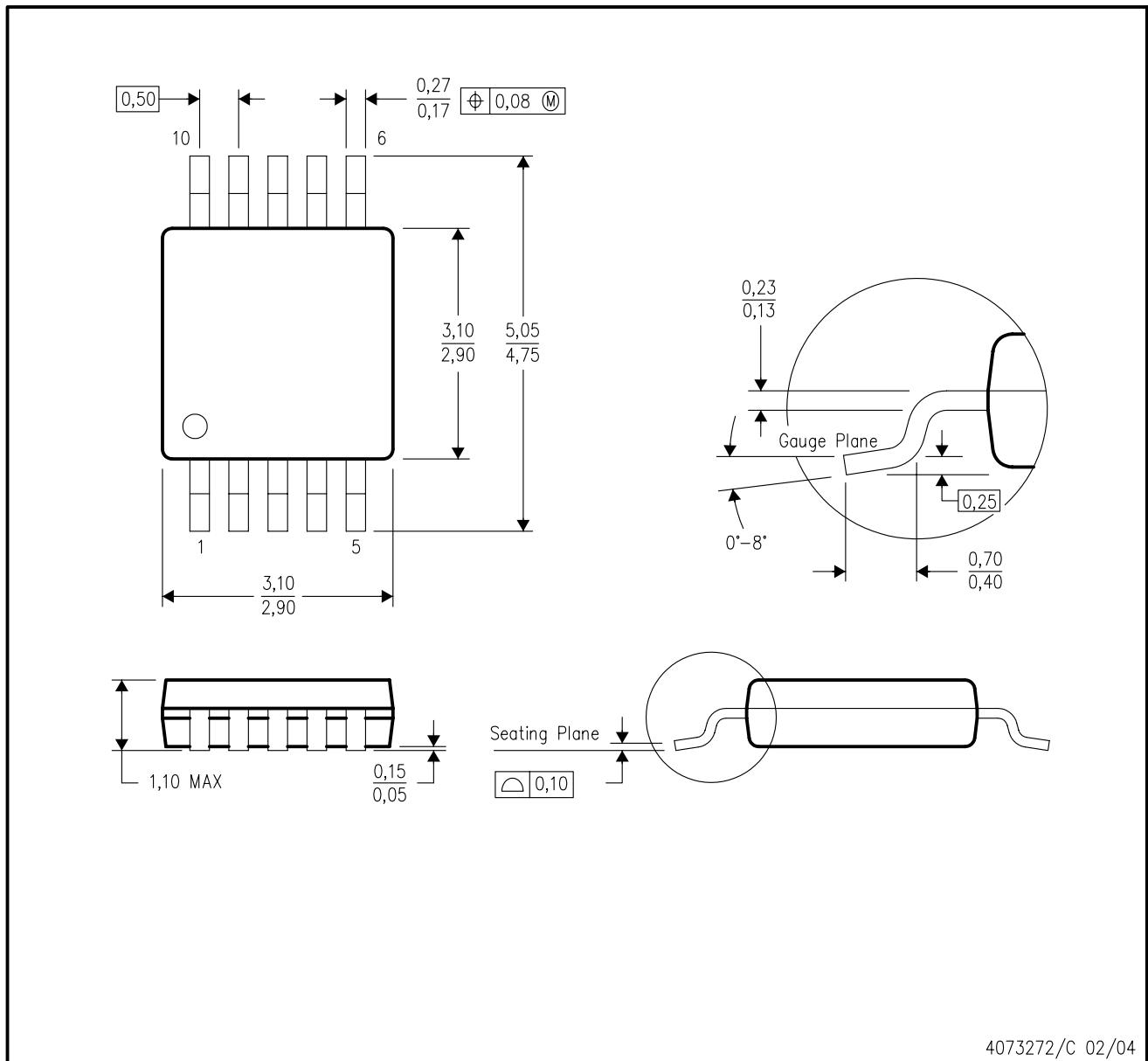

- NOTES:
- A. All linear dimensions are in millimeters.
 - B. This drawing is subject to change without notice.
 - C. Body dimensions do not include mold flash or protrusion.
 - D. Falls within JEDEC MO-187 variation BA.

DGS (S-PDSO-G10)

PLASTIC SMALL OUTLINE PACKAGE

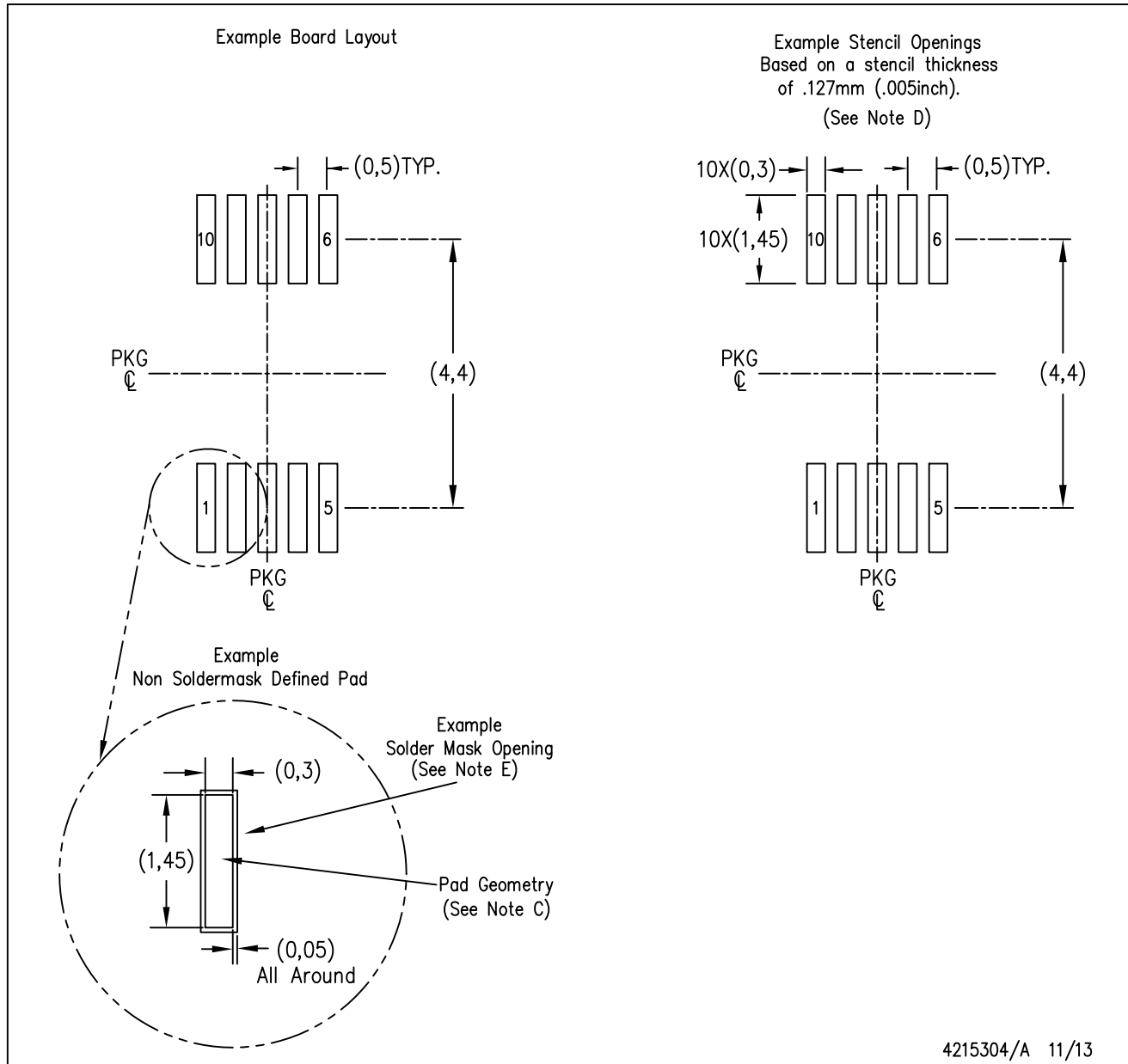

- NOTES:
- A. All linear dimensions are in millimeters.
 - B. This drawing is subject to change without notice.
 - C. Publication IPC-7351 is recommended for alternate designs.
 - D. Laser cutting apertures with trapezoidal walls and also rounding corners will offer better paste release. Customers should contact their board assembly site for stencil design recommendations. Refer to IPC-7525 for other stencil recommendations.
 - E. Customers should contact their board fabrication site for solder mask tolerances between and around signal pads.

D (R-PDSO-G14)

PLASTIC SMALL OUTLINE



- NOTES:
- A. All linear dimensions are in millimeters.
 - B. This drawing is subject to change without notice.
 - C. Publication IPC-7351 is recommended for alternate designs.
 - D. Laser cutting apertures with trapezoidal walls and also rounding corners will offer better paste release. Customers should contact their board assembly site for stencil design recommendations. Refer to IPC-7525 for other stencil recommendations.
 - E. Customers should contact their board fabrication site for solder mask tolerances between and around signal pads.

PW (R-PDSO-G14)

PLASTIC SMALL OUTLINE



- NOTES:
- All linear dimensions are in millimeters.
 - This drawing is subject to change without notice.
 - Publication IPC-7351 is recommended for alternate designs.
 - Laser cutting apertures with trapezoidal walls and also rounding corners will offer better paste release. Customers should contact their board assembly site for stencil design recommendations. Refer to IPC-7525 for other stencil recommendations.
 - Customers should contact their board fabrication site for solder mask tolerances between and around signal pads.

RSV (R-PUQFN-N16)

PLASTIC QUAD FLATPACK NO-LEAD

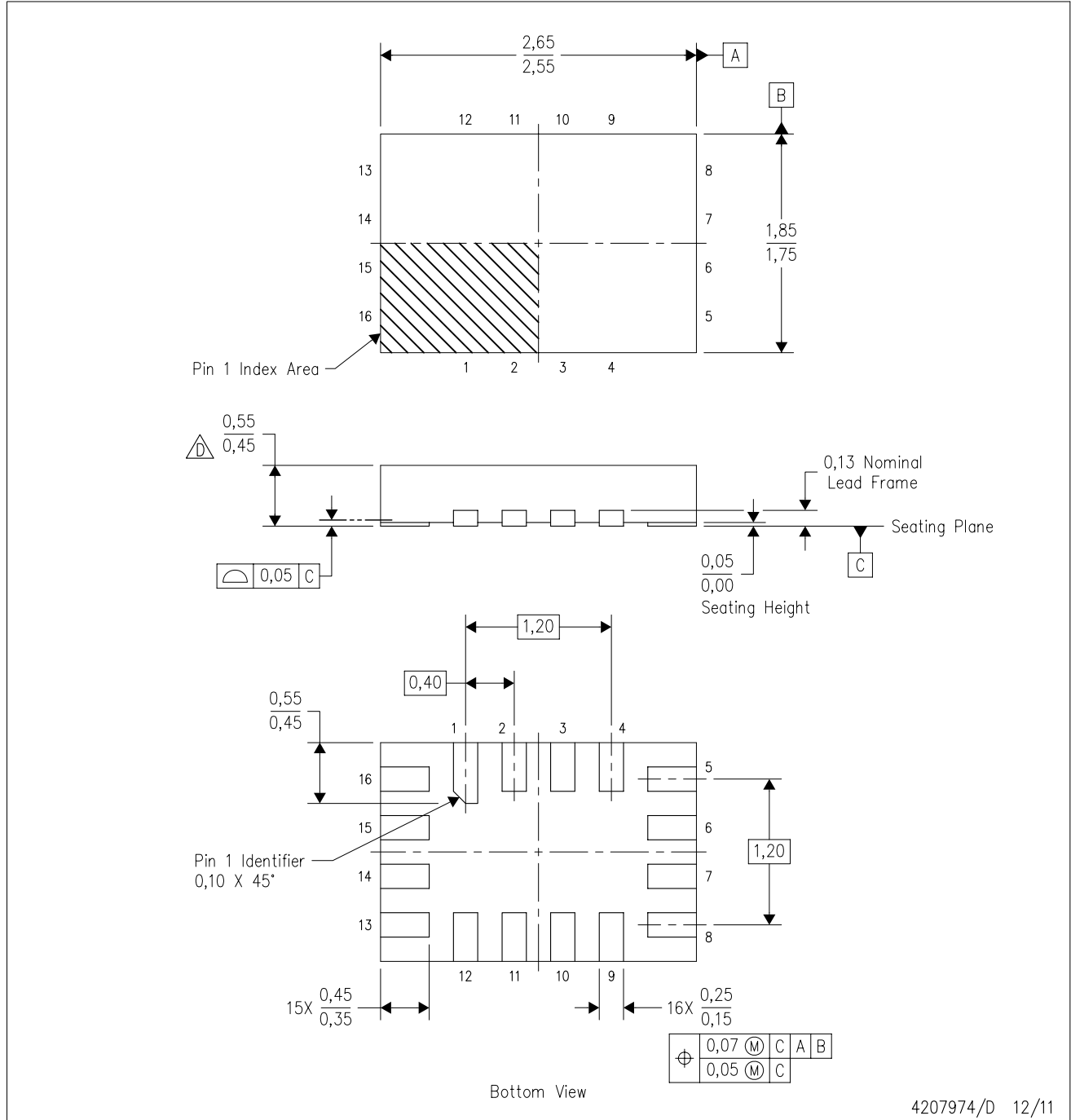

4207974/D 12/11

- NOTES:
- A. All linear dimensions are in millimeters. Dimensioning and tolerancing per ASME Y14.5M-1994.
 - B. This drawing is subject to change without notice.
 - C. QFN (Quad Flatpack No-Lead) package configuration.
 - This package complies to JEDEC MO-288 variation UFHE, except minimum package thickness.

RSV (R-PUQFN-N16)

PLASTIC QUAD FLATPACK NO-LEAD

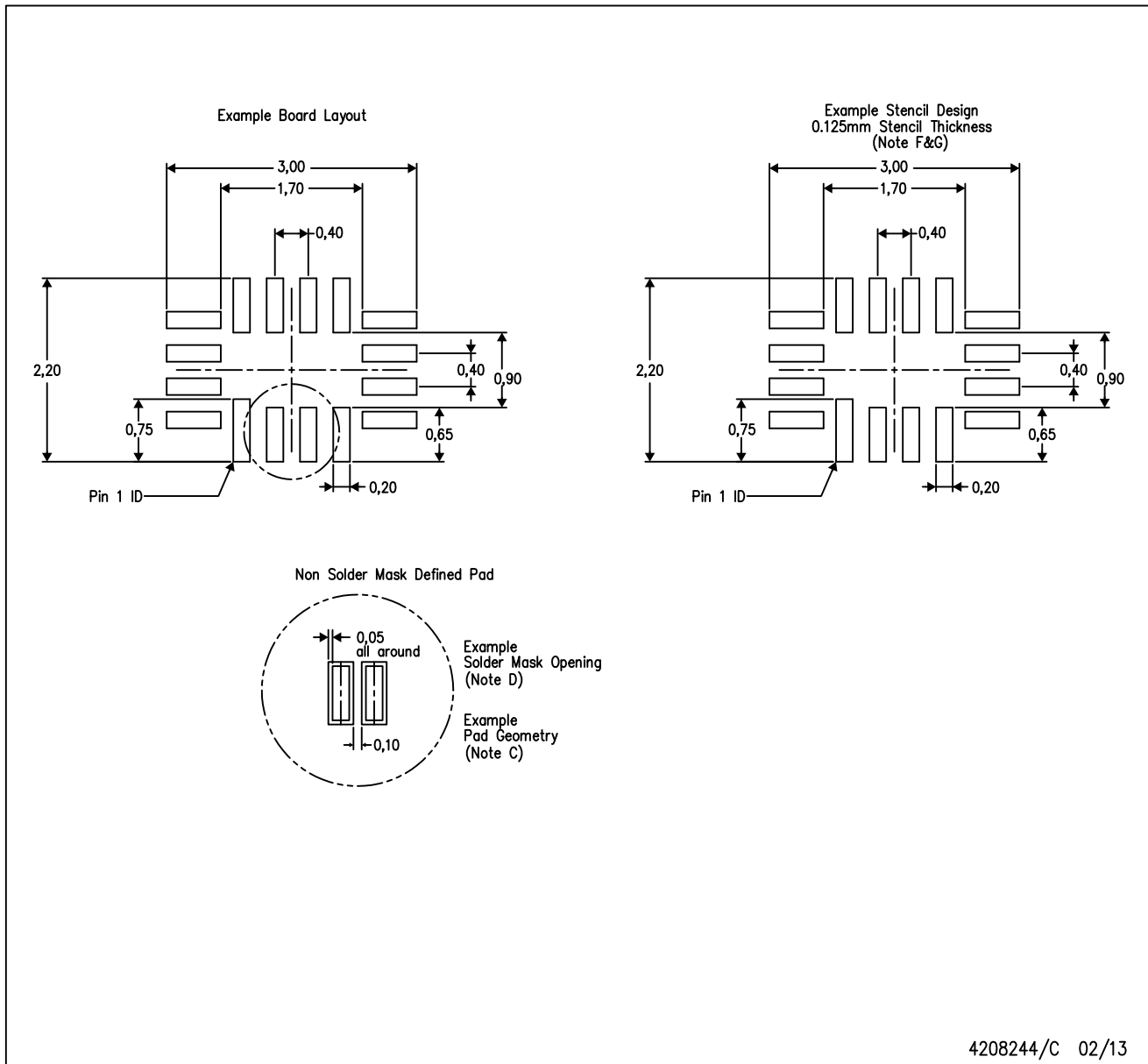

- NOTES:
- A. All linear dimensions are in millimeters.
 - B. This drawing is subject to change without notice.
 - C. Publication IPC-7351 is recommended for alternate designs.
 - D. Customers should contact their board fabrication site for minimum solder mask web tolerances between signal pads.
 - E. Maximum stencil thickness 0,127 mm (5 mils). All linear dimensions are in millimeters.
 - F. Laser cutting apertures with trapezoidal walls and also rounding corners will offer better paste release. Customers should contact their board assembly site for stencil design recommendations. Refer to IPC 7525 for stencil design considerations.
 - G. Side aperture dimensions over-print land for acceptable area ratio > 0.66. Customer may reduce side aperture dimensions if stencil manufacturing process allows for sufficient release at smaller opening.

D (R-PDSO-G8)

PLASTIC SMALL OUTLINE

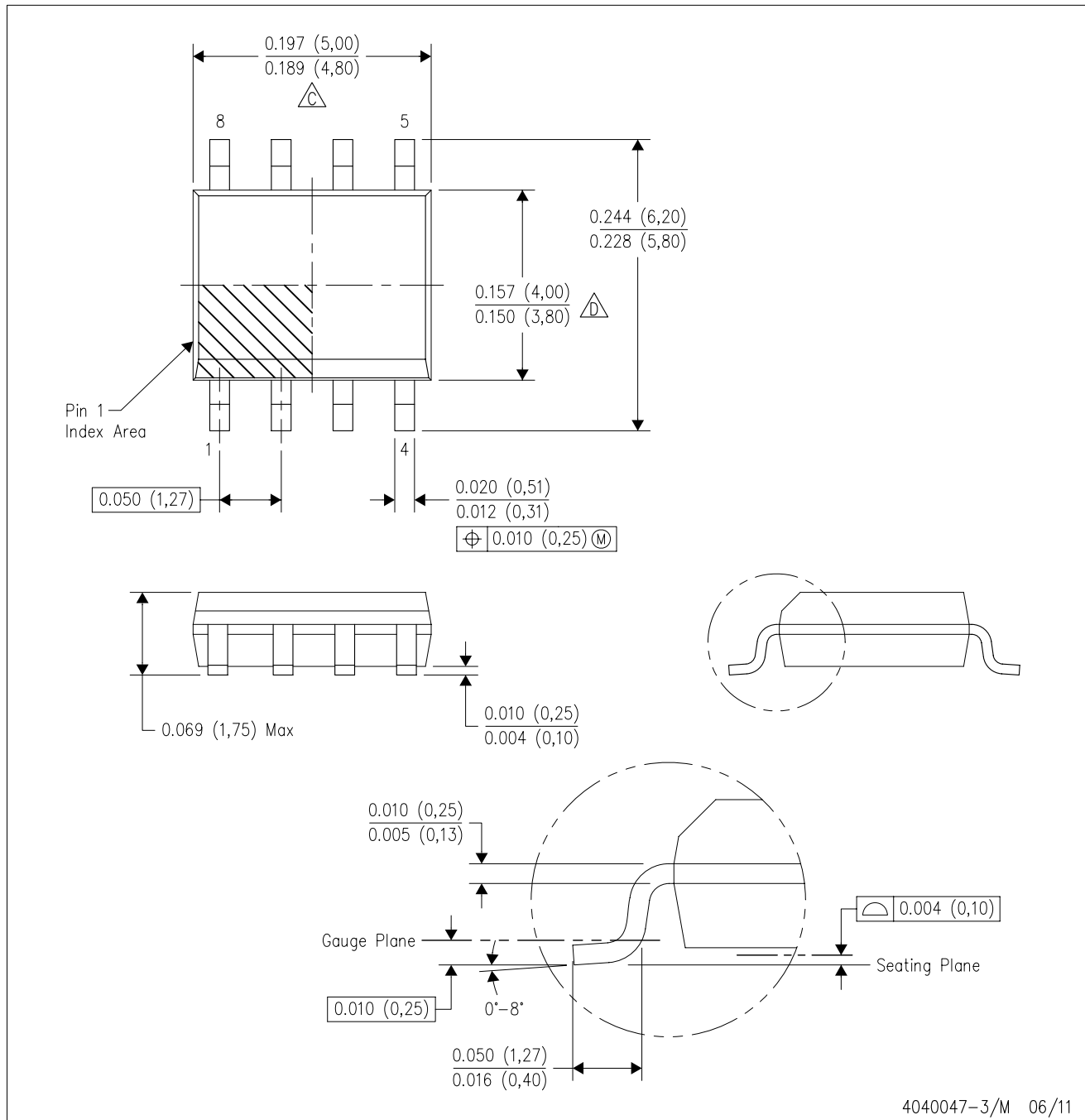

4040047-3/M 06/11

- NOTES:
- A. All linear dimensions are in inches (millimeters).
 - B. This drawing is subject to change without notice.
 - $\triangle C$ Body length does not include mold flash, protrusions, or gate burrs. Mold flash, protrusions, or gate burrs shall not exceed 0.006 (0,15) each side.
 - $\triangle D$ Body width does not include interlead flash. Interlead flash shall not exceed 0.017 (0,43) each side.
 - E. Reference JEDEC MS-012 variation AA.

D (R-PDSO-G8)

PLASTIC SMALL OUTLINE

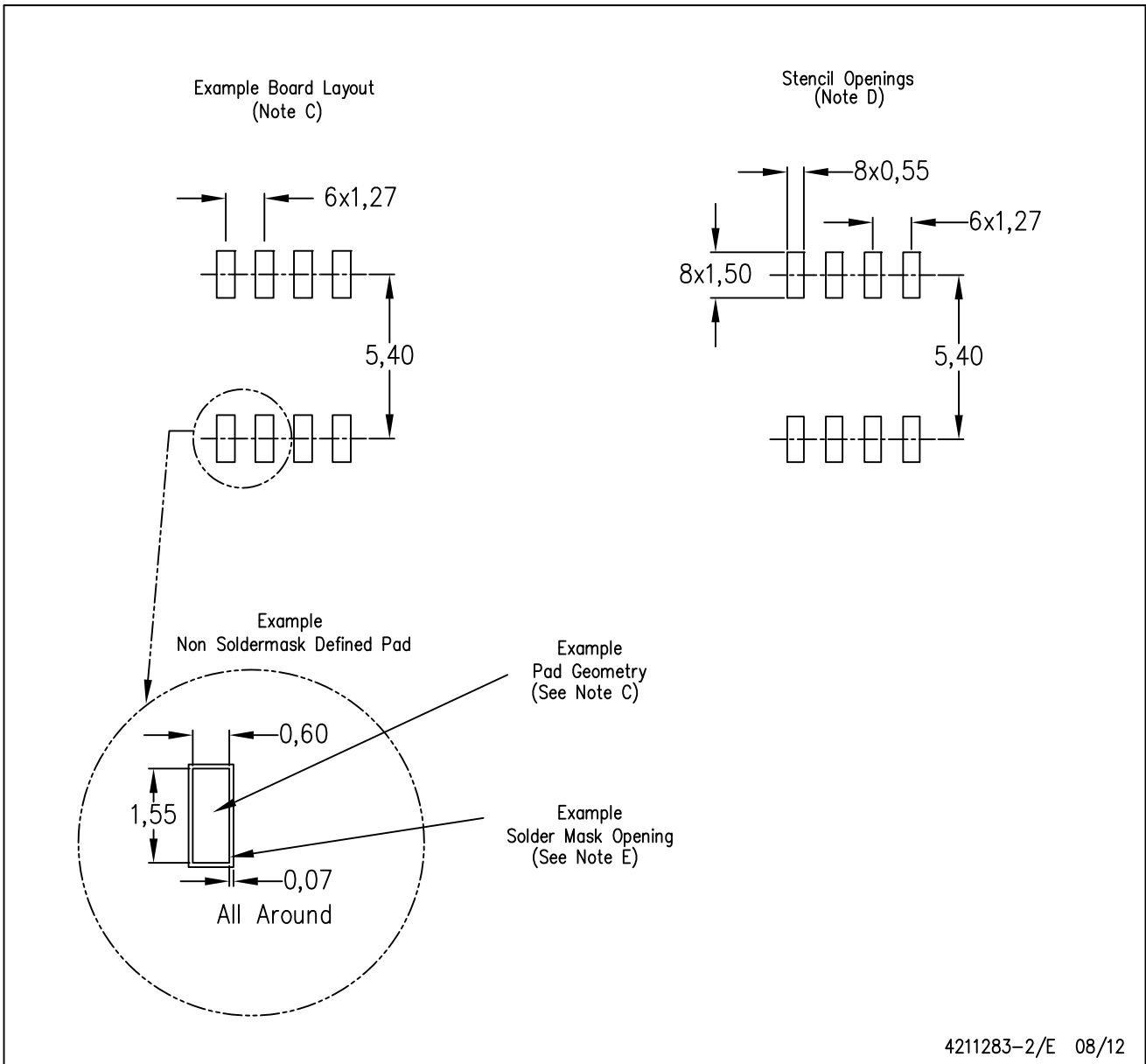

4211283-2/E 08/12

- NOTES:
- A. All linear dimensions are in millimeters.
 - B. This drawing is subject to change without notice.
 - C. Publication IPC-7351 is recommended for alternate designs.
 - D. Laser cutting apertures with trapezoidal walls and also rounding corners will offer better paste release. Customers should contact their board assembly site for stencil design recommendations. Refer to IPC-7525 for other stencil recommendations.
 - E. Customers should contact their board fabrication site for solder mask tolerances between and around signal pads.

IMPORTANT NOTICE

Texas Instruments Incorporated and its subsidiaries (TI) reserve the right to make corrections, enhancements, improvements and other changes to its semiconductor products and services per JESD46, latest issue, and to discontinue any product or service per JESD48, latest issue. Buyers should obtain the latest relevant information before placing orders and should verify that such information is current and complete. All semiconductor products (also referred to herein as "components") are sold subject to TI's terms and conditions of sale supplied at the time of order acknowledgment.

TI warrants performance of its components to the specifications applicable at the time of sale, in accordance with the warranty in TI's terms and conditions of sale of semiconductor products. Testing and other quality control techniques are used to the extent TI deems necessary to support this warranty. Except where mandated by applicable law, testing of all parameters of each component is not necessarily performed.

TI assumes no liability for applications assistance or the design of Buyers' products. Buyers are responsible for their products and applications using TI components. To minimize the risks associated with Buyers' products and applications, Buyers should provide adequate design and operating safeguards.

TI does not warrant or represent that any license, either express or implied, is granted under any patent right, copyright, mask work right, or other intellectual property right relating to any combination, machine, or process in which TI components or services are used. Information published by TI regarding third-party products or services does not constitute a license to use such products or services or a warranty or endorsement thereof. Use of such information may require a license from a third party under the patents or other intellectual property of the third party, or a license from TI under the patents or other intellectual property of TI.

Reproduction of significant portions of TI information in TI data books or data sheets is permissible only if reproduction is without alteration and is accompanied by all associated warranties, conditions, limitations, and notices. TI is not responsible or liable for such altered documentation. Information of third parties may be subject to additional restrictions.

Resale of TI components or services with statements different from or beyond the parameters stated by TI for that component or service voids all express and any implied warranties for the associated TI component or service and is an unfair and deceptive business practice. TI is not responsible or liable for any such statements.

Buyer acknowledges and agrees that it is solely responsible for compliance with all legal, regulatory and safety-related requirements concerning its products, and any use of TI components in its applications, notwithstanding any applications-related information or support that may be provided by TI. Buyer represents and agrees that it has all the necessary expertise to create and implement safeguards which anticipate dangerous consequences of failures, monitor failures and their consequences, lessen the likelihood of failures that might cause harm and take appropriate remedial actions. Buyer will fully indemnify TI and its representatives against any damages arising out of the use of any TI components in safety-critical applications.

In some cases, TI components may be promoted specifically to facilitate safety-related applications. With such components, TI's goal is to help enable customers to design and create their own end-product solutions that meet applicable functional safety standards and requirements. Nonetheless, such components are subject to these terms.

No TI components are authorized for use in FDA Class III (or similar life-critical medical equipment) unless authorized officers of the parties have executed a special agreement specifically governing such use.

Only those TI components which TI has specifically designated as military grade or "enhanced plastic" are designed and intended for use in military/aerospace applications or environments. Buyer acknowledges and agrees that any military or aerospace use of TI components which have **not** been so designated is solely at the Buyer's risk, and that Buyer is solely responsible for compliance with all legal and regulatory requirements in connection with such use.

TI has specifically designated certain components as meeting ISO/TS16949 requirements, mainly for automotive use. In any case of use of non-designated products, TI will not be responsible for any failure to meet ISO/TS16949.

Products

Audio	www.ti.com/audio
Amplifiers	amplifier.ti.com
Data Converters	dataconverter.ti.com
DLP® Products	www.dlp.com
DSP	dsp.ti.com
Clocks and Timers	www.ti.com/clocks
Interface	interface.ti.com
Logic	logic.ti.com
Power Mgmt	power.ti.com
Microcontrollers	microcontroller.ti.com
RFID	www.ti-rfid.com
OMAP Applications Processors	www.ti.com/omap
Wireless Connectivity	www.ti.com/wirelessconnectivity

Applications

Automotive and Transportation	www.ti.com/automotive
Communications and Telecom	www.ti.com/communications
Computers and Peripherals	www.ti.com/computers
Consumer Electronics	www.ti.com/consumer-apps
Energy and Lighting	www.ti.com/energy
Industrial	www.ti.com/industrial
Medical	www.ti.com/medical
Security	www.ti.com/security
Space, Avionics and Defense	www.ti.com/space-avionics-defense
Video and Imaging	www.ti.com/video

TI E2E Community

e2e.ti.com