

50-MHz Low-Distortion High-CMRR Rail-to-Rail I/O, Single-Supply Operational Amplifier

Check for Samples: [OPA365-Q1](#), [OPA2365-Q1](#)

FEATURES

- Qualified for Automotive Applications
- AEC-Q100 Qualified With the Following Results:
 - Device Temperature Grade 1: -40°C to 125°C Ambient Operating Temperature Range
 - Device HBM ESD Classification Level H2
 - Device CDM ESD Classification Level C3B
- Gain Bandwidth: 50 MHz
- Zero-Crossover Distortion Topology
 - Excellent THD+N: 0.0004%
 - CMRR: 100 dB (Min)
 - Rail-to-Rail Input and Output
 - Input 100 mV Beyond Supply Rail
- Low Noise: $4.5\text{ nV}/\sqrt{\text{Hz}}$ at 100 kHz
- Slew Rate: 25 V/ μs
- Fast Settling: 0.3 μs to 0.01%
- Precision
 - Low Offset: 100 μV

- Low Input Bias Current: 0.2 pA
- 2.2-V to 5.5-V Operation

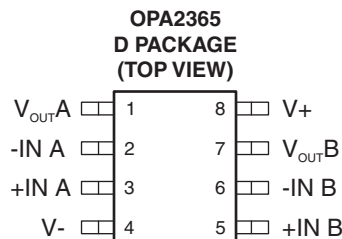
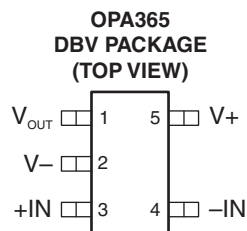

DESCRIPTION

The OPAx365 zero-crossover family, rail-to-rail, high-performance, CMOS operational amplifiers are optimized for very low voltage, single-supply applications. Rail-to-rail input/output, low-noise ($4.5\text{ nV}/\sqrt{\text{Hz}}$) and high-speed operation (50-MHz gain bandwidth) make these devices ideal for driving sampling analog-to-digital converters (ADCs). Applications include audio, signal conditioning, and sensor amplification. The OPA365 family of op amps are also well-suited for cell phone power amplifier control loops.

Special features include an excellent common-mode rejection ratio (CMRR), no input stage crossover distortion, high input impedance, and rail-to-rail input and output swing. The input common-mode range includes both the negative and positive supplies. The output voltage swing is within 10 mV of the rails.

The OPA365 (single version) is available in the SOT23-5 package. The OPA2365 (dual version) is available in the SO-8 package. All versions are specified for operation from -40°C to 125°C . Single and dual versions have identical specifications for maximum design flexibility.



Please be aware that an important notice concerning availability, standard warranty, and use in critical applications of Texas Instruments semiconductor products and disclaimers thereto appears at the end of this data sheet.

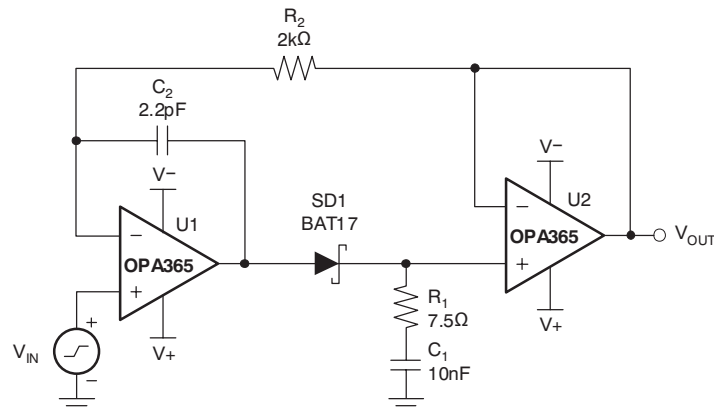

Figure 1. Fast-Settling Peak Detector



This integrated circuit can be damaged by ESD. Texas Instruments recommends that all integrated circuits be handled with appropriate precautions. Failure to observe proper handling and installation procedures can cause damage.

ESD damage can range from subtle performance degradation to complete device failure. Precision integrated circuits may be more susceptible to damage because very small parametric changes could cause the device not to meet its published specifications.

ORDERING INFORMATION⁽¹⁾

T _A	PACKAGE ⁽²⁾			ORDERABLE PART NUMBER	TOP-SIDE MARKING
-40°C to 125°C	Single	SOT23 – DBV	Reel of 2500	OPA365AQDBVRQ1	OTNQ
	Dual	SOIC – D	Reel of 2500	OPA2365AQDRQ1	O2365Q

- (1) For the most current package and ordering information, see the Package Option Addendum at the end of this document, or see the TI web site at www.ti.com.
- (2) Package drawings, thermal data, and symbolization are available at www.ti.com/packaging.

ABSOLUTE MAXIMUM RATINGS⁽¹⁾

V _{CC}	Supply voltage		+5.5 V
V _I	Signal input terminals, voltage ⁽²⁾		(V ₋) - 0.5V to (V ₊) + 0.5 V
I _I	Signal input terminals, current ⁽²⁾		±10 mA
t _{OSC}	Output short-circuit duration ⁽³⁾		Continuous
T _{OP}	Operating temperature		-40°C to 150°C
T _{stg}	Storage temperature		-65°C to 150°C
T _J	Junction temperature		150°C
ESD	Electrostatic discharge rating	Human Body Model (HBM) AEC-Q100 Classification Level H2	2 kV
		Charged Device Model (CDM) AEC-Q100 Classification Level C3B	750 V

- (1) Stresses beyond those listed under *absolute maximum ratings* may cause permanent damage to the device. These are stress ratings only, and functional operation of the device at these or any other conditions beyond those indicated under *recommended operating conditions* is not implied. Exposure to absolute-maximum-rated conditions for extended periods may affect device reliability.
- (2) Input terminals are diode-clamped to the power-supply rails. Input signals that can swing more than 0.5V beyond the supply rails should be current limited to 10mA or less.
- (3) Short-circuit to ground, one amplifier per package

ELECTRICAL CHARACTERISTICS

 $V_S = +2.2V$ to $+5.5V$, $R_L = 10k\Omega$ connected to $V_S/2$, $V_{CM} = V_S/2$, and $V_{OUT} = V_S/2$ (unless otherwise noted)

PARAMETER		TEST CONDITIONS	T_A ⁽¹⁾	MIN	TYP	MAX	UNIT
OFFSET VOLTAGE							
V_{OS}	Input offset voltage		25°C		100	200	μV
$V_{OS}^{(2)}$	Input offset voltage		25°C		100	230	μV
dV_{OS}/dT	Input offset voltage drift		Full range		1		$\mu V/^\circ C$
PSRR	Input offset voltage vs power supply	$V_S = +2.2V$ to $+5.5V$	Full range		10	100	$\mu V/V$
	Channel separation, dc		25°C		0.2		$\mu V/V$
INPUT BIAS CURRENT							
I_B	Input bias current		25°C		± 0.2	± 10	pA
			Full range	See Typical Characteristics			
I_{OS}	Input offset current		25°C		± 0.2	± 10	pA
NOISE							
e_n	Input voltage noise	$f = 0.1Hz$ to $10Hz$	25°C		5		μV_{PP}
e_n	Input voltage noise density	$f = 100kHz$	25°C		4.5		nV/\sqrt{Hz}
i_n	Input current noise density	$f = 10kHz$	25°C		4		fA/\sqrt{Hz}
INPUT VOLTAGE RANGE							
V_{CM}	Common-mode voltage range		25°C	$(V_-) - 0.1$		$(V_+) + 0.1$	V
CMRR	Common-mode rejection ratio	$(V_-) - 0.1V \leq V_{CM} \leq (V_+) + 0.1V$	Full range	100	120		dB
INPUT CAPACITANCE							
	Differential		25°C		6		pF
	Common-mode		25°C		2		pF
OPEN-LOOP GAIN							
A_{OL}	Open-loop voltage gain	$R_L = 10k\Omega$, $100mV < V_O < (V_+) - 100mV$	Full range	100	120		dB
		$R_L = 600\Omega$, $200mV < V_O < (V_+) - 200mV$	25°C	100	120		
		$R_L = 600\Omega$, $200mV < V_O < (V_+) - 200mV$	Full range	94			
FREQUENCY RESPONSE							
GBW	Gain-bandwidth product		25°C		50		MHz
SR	Slew rate	$V_S = 5V$, $G = +1$	25°C		25		V/ μs
t_s	Settling time	0.1%, $V_S = 5V$, 4V Step, $G = +1$	25°C		200		ns
		0.01%, $V_S = 5V$, 4V Step, $G = +1$	25°C		300		
	Overload recovery time	$V_S = 5V$, $V_{IN} \times Gain > V_S$	25°C		< 0.1		μs
THD+N	Total harmonic distortion + noise ⁽³⁾	$V_S = 5V$, $R_L = 600\Omega$, $V_O = 4V_{PP}$, $G = +1$, $f = 1kHz$	25°C		0.0004		%
OUTPUT							
	Voltage output swing from rail	$R_L = 10k\Omega$, $V_S = 5.5V$	Full range		10	20	mV
I_{SC}	Short-circuit current		25°C		± 65		mA
C_L	Capacitive load drive		25°C	See Typical Characteristics			
	Open-loop output impedance	$f = 1MHz$, $I_O = 0$	25°C		30		Ω
POWER SUPPLY							
V_S	Specified voltage range		25°C	2.2		5.5	V

 (1) Full range $T_A = -40^\circ C$ to $+125^\circ C$

(2) For OPA2365-Q1 only

(3) Third-order filter, bandwidth 80kHz at -3dB.

ELECTRICAL CHARACTERISTICS (continued)

$V_S = +2.2V$ to $+5.5V$, $R_L = 10k\Omega$ connected to $V_S/2$, $V_{CM} = V_S/2$, and $V_{OUT} = V_S/2$ (unless otherwise noted)

PARAMETER	TEST CONDITIONS	$T_A^{(1)}$	MIN	TYP	MAX	UNIT
I_Q Quiescent current per amplifier	$I_O = 0$	25°C		4.6	5	mA
		Full range			5.3	
TEMPERATURE RANGE						
Specified range		25°C	-40		125	°C
θ_{JA} Thermal resistance	SOT23-5	25°C				°C/W
	SO-8	25°C		200		

TYPICAL CHARACTERISTICS

$T_A = +25^\circ\text{C}$, $V_S = +5\text{V}$, $C_L = 0\text{pF}$ (unless otherwise noted)

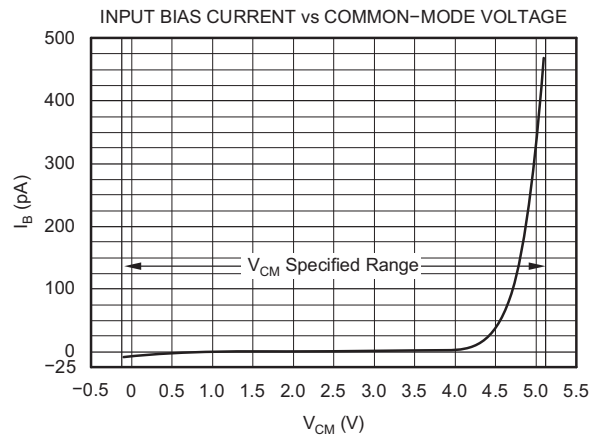
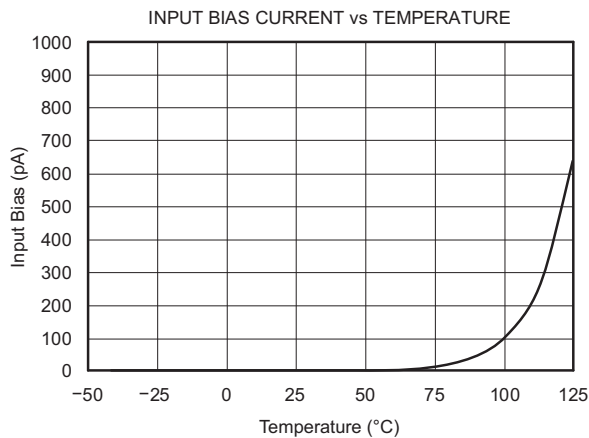
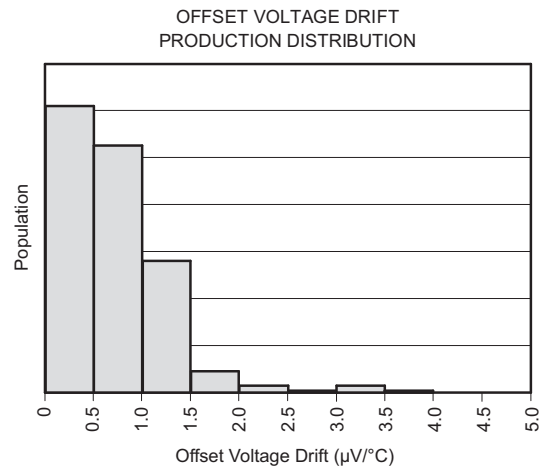
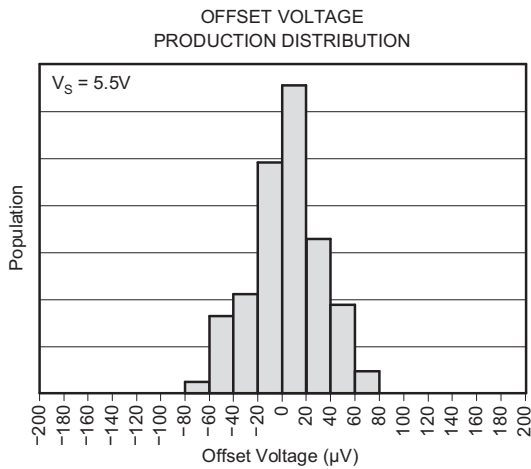
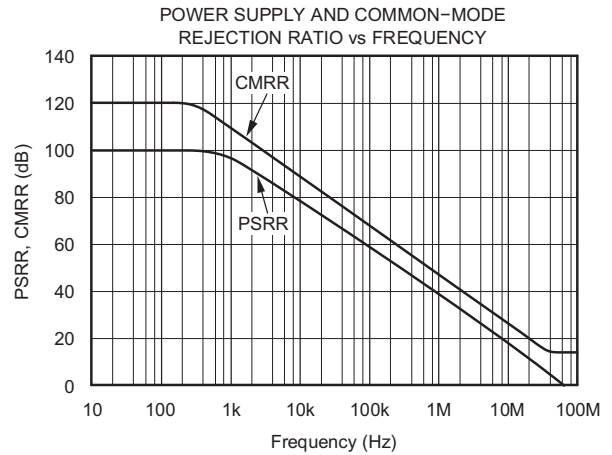
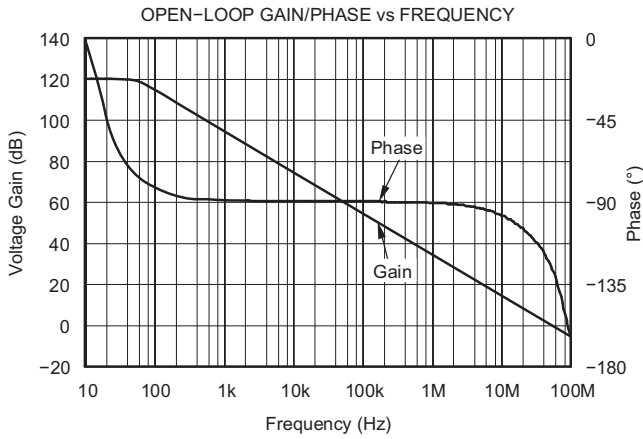

TYPICAL CHARACTERISTICS (continued)

$T_A = +25^\circ\text{C}$, $V_S = +5\text{V}$, $C_L = 0\text{pF}$ (unless otherwise noted)

OPA365 OUTPUT VOLTAGE
vs OUTPUT CURRENT

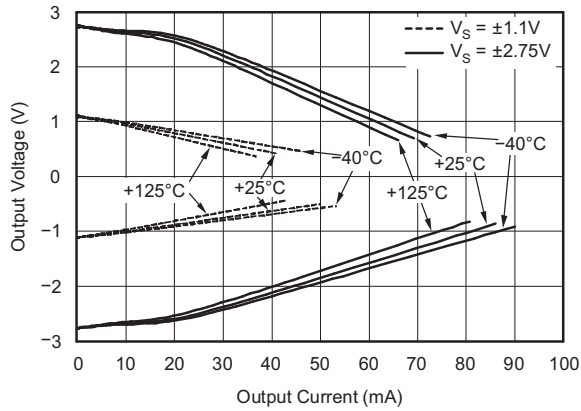

OPA2365 OUTPUT VOLTAGE SWING
vs OUTPUT CURRENT

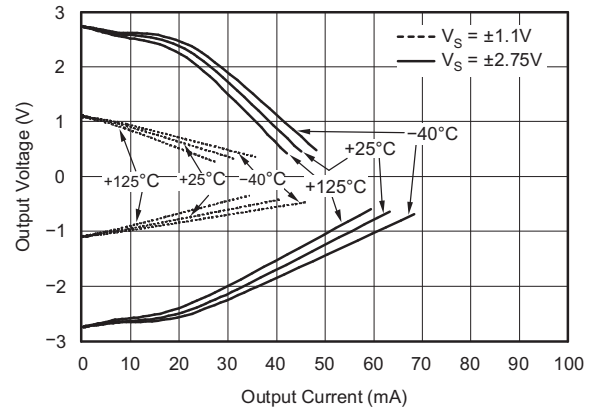

SHORT-CIRCUIT CURRENT vs TEMPERATURE

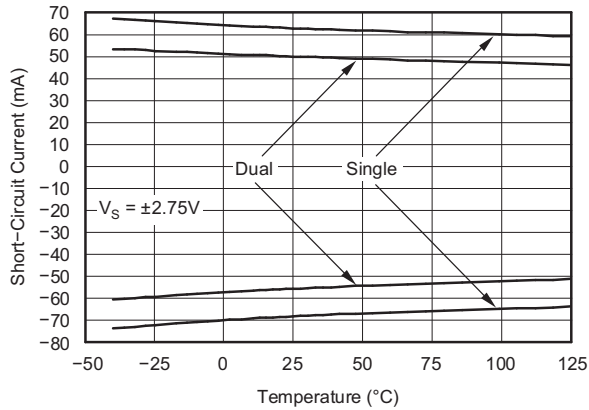

QUIESCENT CURRENT vs SUPPLY VOLTAGE

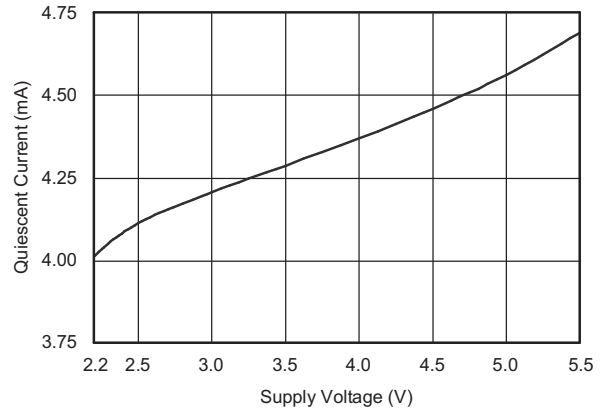

QUIESCENT CURRENT vs TEMPERATURE

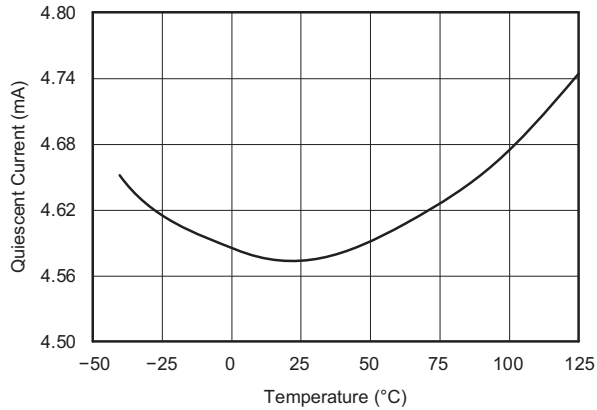

0.1Hz to 10Hz
INPUT VOLTAGE NOISE

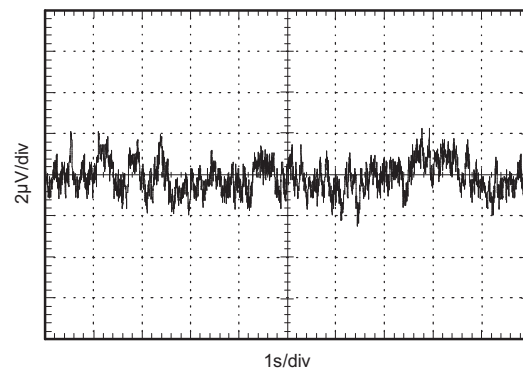

TYPICAL CHARACTERISTICS (continued)

$T_A = +25^\circ\text{C}$, $V_S = +5\text{V}$, $C_L = 0\text{pF}$ (unless otherwise noted)

TOTAL HARMONIC DISTORTION + NOISE vs FREQUENCY

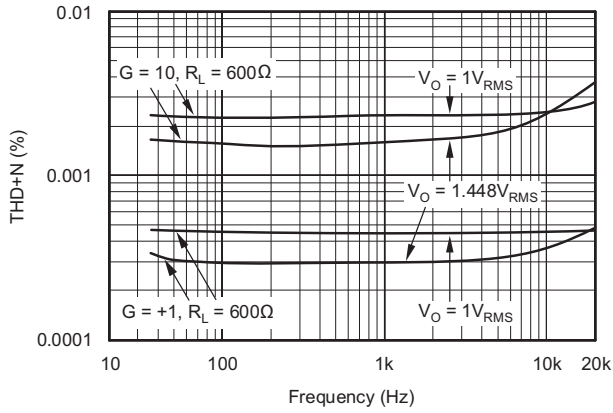

INPUT VOLTAGE NOISE SPECTRAL DENSITY

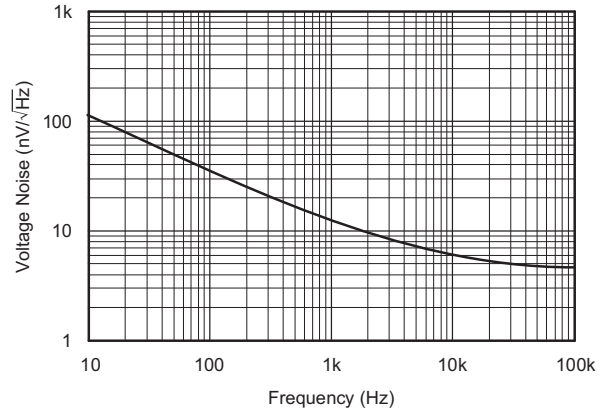

OVERSHOOT vs CAPACITIVE LOAD

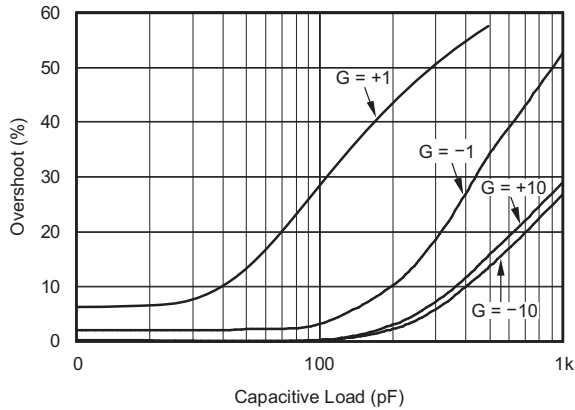

SMALL-SIGNAL STEP RESPONSE

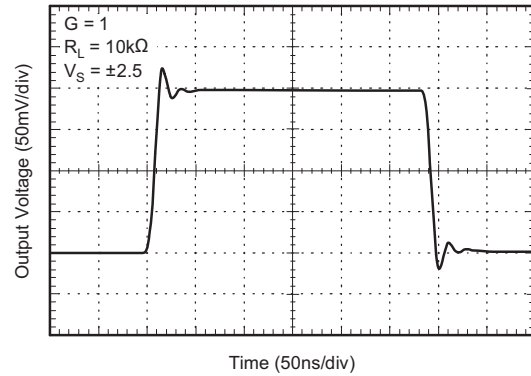

LARGE-SIGNAL STEP RESPONSE

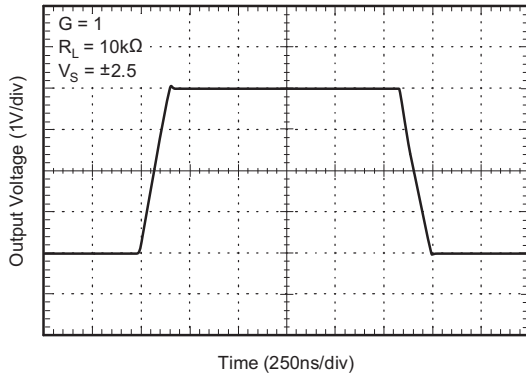

SMALL-SIGNAL STEP RESPONSE

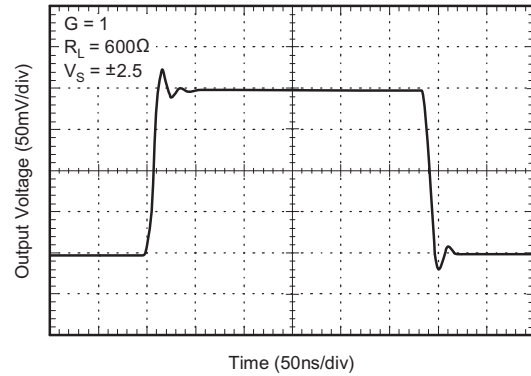

TYPICAL CHARACTERISTICS (continued)

$T_A = +25^\circ\text{C}$, $V_S = +5\text{V}$, $C_L = 0\text{pF}$ (unless otherwise noted)

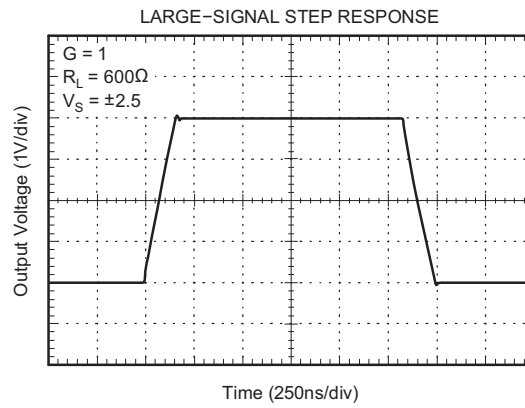

APPLICATION INFORMATION

Operating Characteristics

The OPA365 amplifier parameters are fully specified from +2.2V to +5.5V. Many of the specifications apply from -40°C to $+125^{\circ}\text{C}$. Parameters that can exhibit significant variance with regard to operating voltage or temperature are presented in *Typical Characteristics*.

General Layout Guidelines

The OPA365 is a wideband amplifier. To realize the full operational performance of the device, good high-frequency printed circuit board (PCB) layout practices are required. Low-loss $0.1\mu\text{F}$ bypass capacitors must be connected between each supply pin and ground as close to the device as possible. The bypass capacitor traces should be designed for minimum inductance.

Basic Amplifier Configurations

As with other single-supply op amps, the OPA365 may be operated with either a single supply or dual supplies (see Figure 2). A typical dual-supply connection is shown in Figure 2, which is accompanied by a single-supply connection. The OPA365 is configured as a basic inverting amplifier with a gain of -10V/V . The dual-supply connection has an output voltage centered on zero, while the single-supply connection has an output centered on the common-mode voltage V_{CM} . For the circuit shown, this voltage is 1.5V, but may be any value within the common-mode input voltage range. The OPA365 V_{CM} range extends 100mV beyond the power-supply rails.

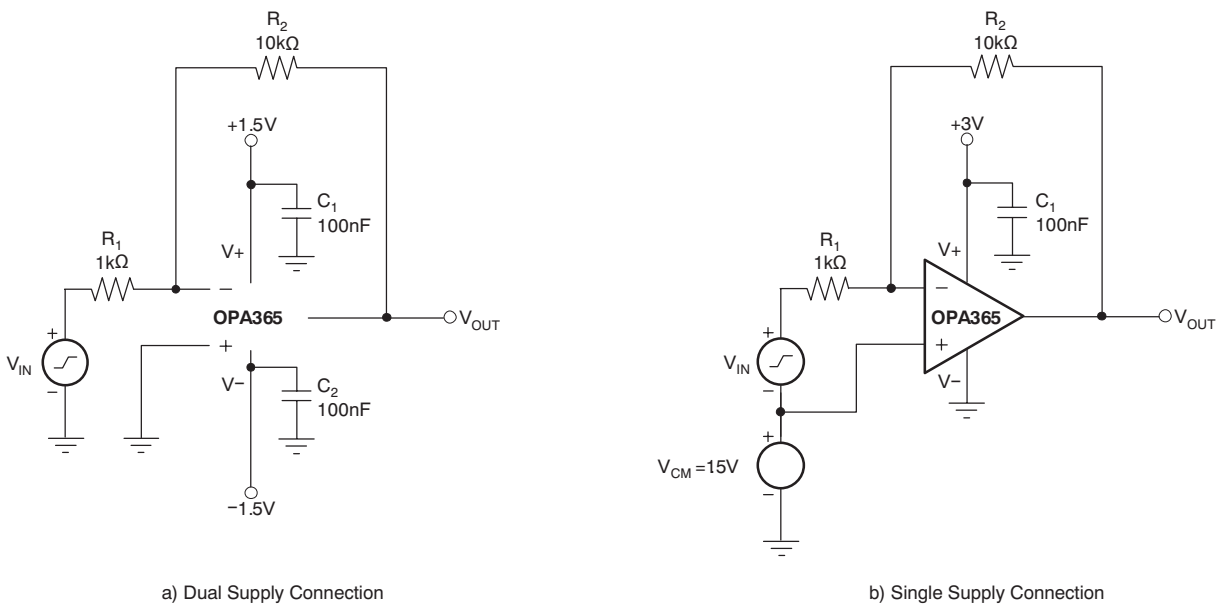

Figure 2. Basic Circuit Connections

Figure 3 shows a single-supply, electret microphone application where V_{CM} is provided by a resistive divider. The divider also provides the bias voltage for the electret element.

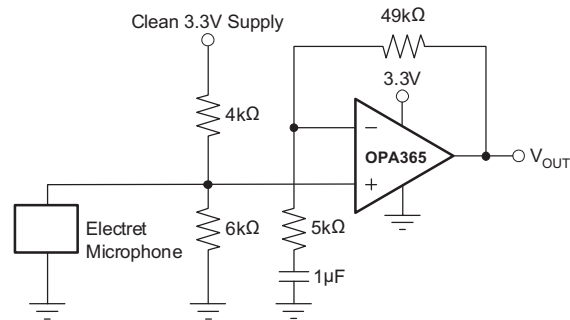

Figure 3. Microphone Preamplifier

Input and ESD Protection

The OPA365 incorporates internal electrostatic discharge (ESD) protection circuits on all pins. In the case of input and output pins, this protection primarily consists of current steering diodes connected between the input and power-supply pins. These ESD protection diodes also provide in-circuit, input overdrive protection, provided that the current is limited to 10mA as stated in the Absolute Maximum Ratings. Figure 4 shows how a series input resistor may be added to the driven input to limit the input current. The added resistor contributes thermal noise at the amplifier input and its value should be kept to the minimum in noise-sensitive applications.

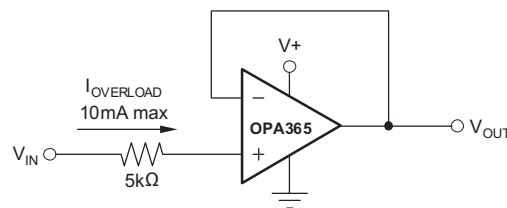

Figure 4. Input Current Protection

Rail-to-Rail Input

The OPA365 product family features true rail-to-rail input operation, with supply voltages as low as $\pm 1.1\text{V}$ (2.2V). A unique zero-crossover input topology eliminates the input offset transition region typical of many rail-to-rail, complementary stage operational amplifiers. This topology also allows the OPA365 to provide superior common-mode performance over the entire input range, which extends 100mV beyond both power-supply rails, as shown in Figure 5. When driving ADCs, the highly linear VCM range of the OPA365 assures that the op amp/ADC system linearity performance is not compromised.

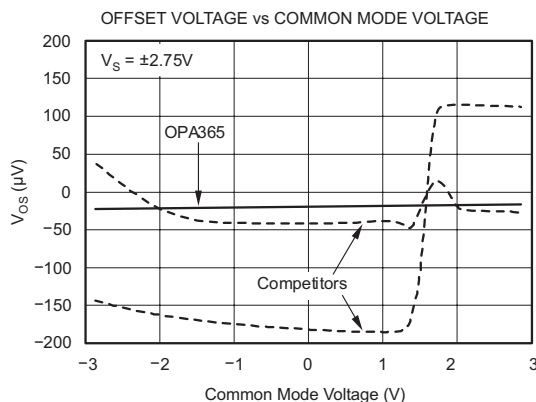

Figure 5. OPA365 has Linear Offset Over the Entire Common-Mode Range

A simplified schematic illustrating the rail-to-rail input circuitry is shown in Figure 6.

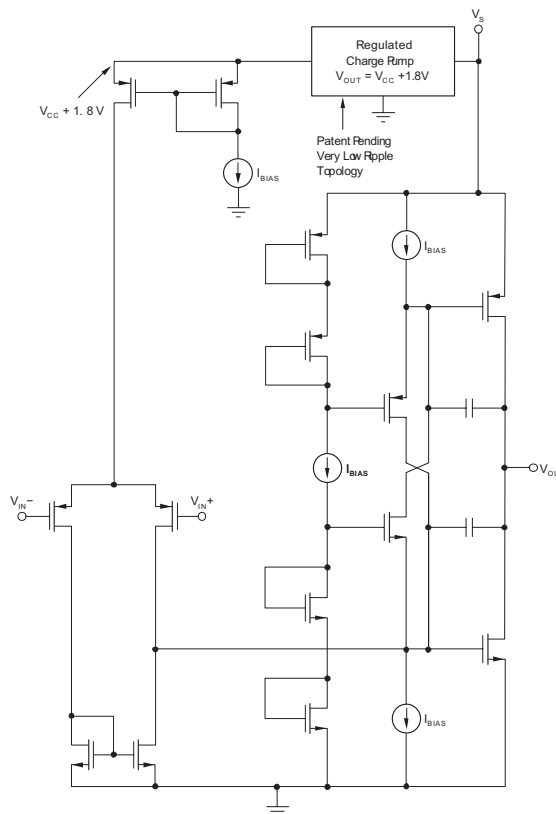

Figure 6. Simplified Schematic

Capacitive Loads

The OPA365 may be used in applications where driving a capacitive load is required. As with all op amps, there may be specific instances where the OPA365 can become unstable, leading to oscillation. The particular op amp circuit configuration, layout, gain and output loading are some of the factors to consider when establishing whether an amplifier will be stable in operation. An op amp in the unity-gain (+1V/V) buffer configuration and driving a capacitive load exhibits a greater tendency to be unstable than an amplifier operated at a higher noise gain. The capacitive load, in conjunction with the op amp output resistance, creates a pole within the feedback loop that degrades the phase margin. The degradation of the phase margin increases as the capacitive loading increases.

When operating in the unity-gain configuration, the OPA365 remains stable with a pure capacitive load up to approximately 1nF. The equivalent series resistance (ESR) of some very large capacitors ($C_L > 1\mu\text{F}$) is sufficient to alter the phase characteristics in the feedback loop such that the amplifier remains stable. Increasing the amplifier closed-loop gain allows the amplifier to drive increasingly larger capacitance. This increased capability is evident when observing the overshoot response of the amplifier at higher voltage gains. See the typical characteristic graph, Small-Signal Overshoot vs. Capacitive Load.

One technique for increasing the capacitive load drive capability of the amplifier operating in unity gain is to insert a small resistor, typically 10Ω to 20Ω , in series with the output; see [Figure 7](#). This resistor significantly reduces the overshoot and ringing associated with large capacitive loads. A possible problem with this technique is that a voltage divider is created with the added series resistor and any resistor connected in parallel with the capacitive load. The voltage divider introduces a gain error at the output that reduces the output swing. The error contributed by the voltage divider may be insignificant. For instance, with a load resistance, $R_L = 10\text{k}\Omega$, and $R_S = 20\Omega$, the gain error is only about 0.2%. However, when R_L is decreased to 600Ω , which the OPA365 is able to drive, the error increases to 7.5%.

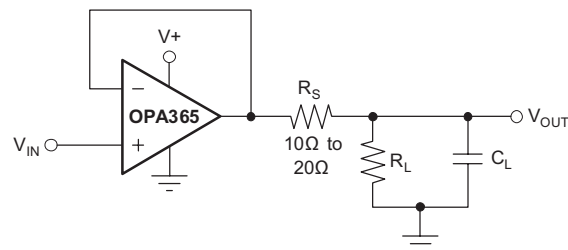

Figure 7. Improving Capacitive Load Drive

Achieving an Output Level of Zero Volts (0V)

Certain single-supply applications require the op amp output to swing from 0V to a positive full-scale voltage and have high accuracy. An example is an op amp employed to drive a single-supply ADC having an input range from 0V to +5V. Rail-to-rail output amplifiers with very light output loading may achieve an output level within millivolts of 0V (or +V_S at the high end), but not 0V. Furthermore, the deviation from 0V only becomes greater as the load current required increases. This increased deviation is a result of limitations of the CMOS output stage.

When a pulldown resistor is connected from the amplifier output to a negative voltage source, the OPA365 can achieve an output level of 0V, and even a few millivolts below 0V. Below this limit, nonlinearity and limiting conditions become evident. Figure 8 illustrates a circuit using this technique.

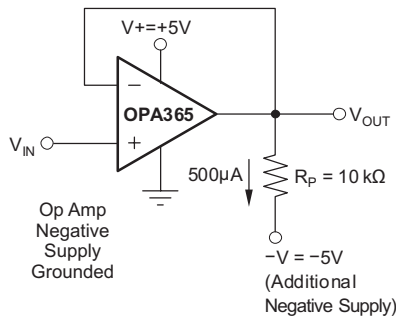

Figure 8. Swing-to-Ground

A pulldown current of approximately 500μA is required when OPA365 is connected as a unity-gain buffer. A practical termination voltage (V_{NEG}) is -5V, but other convenient negative voltages also may be used. The pulldown resistor R_L is calculated from $R_L = [(V_O - V_{NEG}) / (500\mu A)]$. Using a minimum output voltage (V_O) of 0V, $R_L = [0V - (-5V)] / (500\mu A) = 10k\Omega$. Keep in mind that lower termination voltages result in smaller pulldown resistors that load the output during positive output voltage excursions.

Note that this technique does not work with all op amps and should only be applied to op amps such as the OPA365 that have been specifically designed to operate in this manner. Also, operating the OPA365 output at 0V changes the output stage operating conditions, resulting in somewhat lower open-loop gain and bandwidth. Keep these precautions in mind when driving a capacitive load because these conditions can affect circuit transient response and stability.

Active Filtering

The OPA365 is well-suited for active filter applications requiring a wide bandwidth, fast slew rate, low-noise, single-supply operational amplifier. Figure 9 shows a 500kHz, 2nd-order, low-pass filter utilizing the multiple-feedback (MFB) topology. The components have been selected to provide a maximally-flat Butterworth response. Beyond the cutoff frequency, roll-off is -40dB/dec . The Butterworth response is ideal for applications requiring predictable gain characteristics such as the anti-aliasing filter used ahead of an ADC.

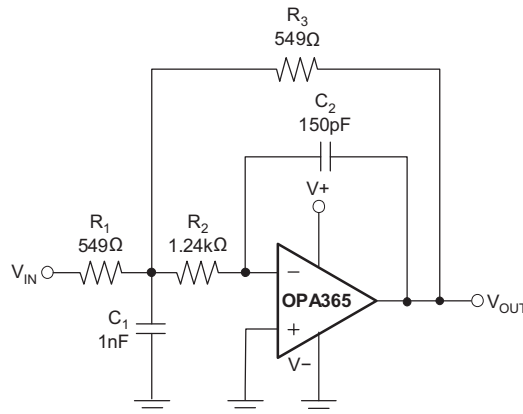

Figure 9. Second-Order Butterworth 500kHz Low-Pass Filter

One point to observe when considering the MFB filter is that the output is inverted, relative to the input. If this inversion is not required, or not desired, a noninverting output can be achieved through one of these options: 1) adding an inverting amplifier; 2) adding an additional 2nd-order MFB stage; or 3) using a noninverting filter topology such as the Sallen-Key (shown in Figure 10). MFB and Sallen-Key, low-pass and high-pass filter synthesis is quickly accomplished using TI's FilterPro program. This software is available as a free download at www.ti.com.

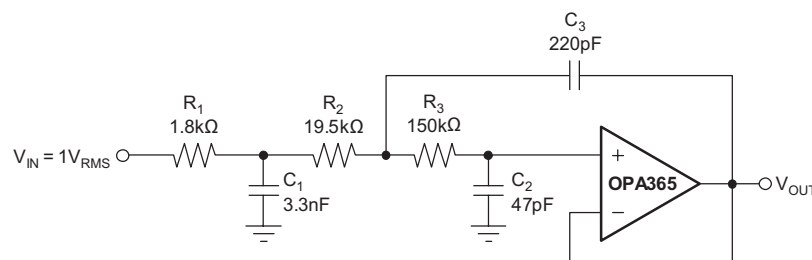

Figure 10. Configured as a 3-Pole, 20kHz, Sallen-Key Filter

Driving an Analog-to-Digital Converter

Very wide common-mode input range, rail-to-rail input and output voltage capability and high speed make the OPA365 an ideal driver for modern ADCs. Also, because it is free of the input offset transition characteristics inherent to some rail-to-rail CMOS op amps, the OPA365 provides low THD and excellent linearity throughout the input voltage swing range. Figure 11 shows the OPA365 driving an ADS8326, 16-bit, 250kSPS converter. The amplifier is connected as a unity-gain, noninverting buffer and has an output swing to 0V, making it directly compatible with the ADC minus full-scale input level. The 0V level is achieved by powering the OPA365 V^- pin with a small negative voltage established by the diode forward voltage drop. A small, signal-switching diode or Schottky diode provides a suitable negative supply voltage of -0.3 to -0.7V . The supply rail-to-rail is equal to $V+$, plus the small negative voltage.

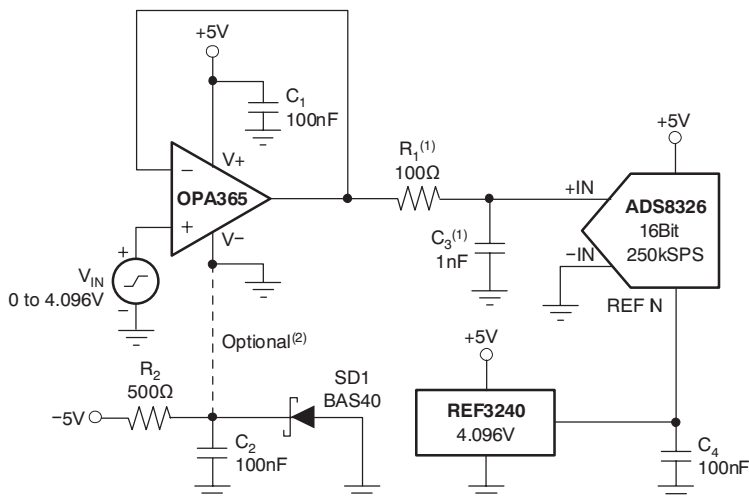

Figure 11. Driving the ADS8326

One method for driving an ADC that negates the need for an output swing down to 0V uses a slightly compressed ADC full-scale input range (FSR). For example, the 16-bit ADS8361 (shown in Figure 12) has a maximum FSR of 0V to 5V, when powered by a +5V supply and V_{REF} of 2.5V. The idea is to match the ADC input range with the op amp full linear output swing range; for example, an output range of +0.1 to +4.9V. The reference output from the ADS8361 ADC is divided down from 2.5V to 2.4V using a resistive divider. The ADC FSR then becomes $4.8V_{PP}$ centered on a common-mode voltage of +2.5V. Current from the ADS8361 reference pin is limited to about $\pm 10\mu A$. Here, $5\mu A$ was used to bias the divider. The resistors must be precise to maintain the ADC gain accuracy. An additional benefit of this method is the elimination of the negative supply voltage; it requires no additional power-supply current.

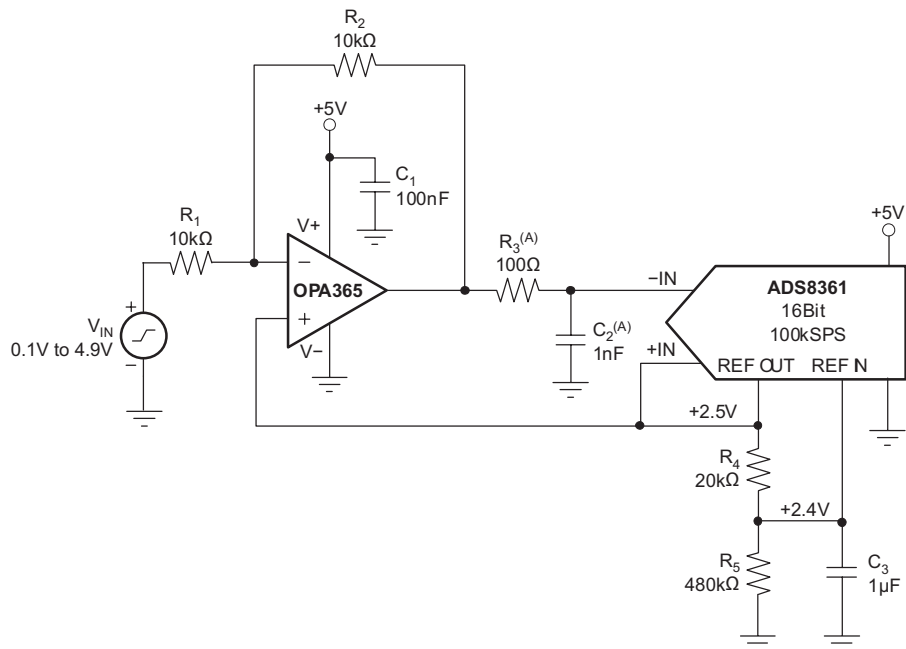

Figure 12. Driving the ADS8361

An RC network, consisting of R1 and C1, is included between the op amp and the ADS8361. It not only provides a high-frequency filter function, but more importantly serves as a charge reservoir used for charging the converter internal hold capacitance. This capability assures that the op amp output linearity is maintained as the ADC input characteristics change throughout the conversion cycle. Depending on the particular application and ADC, some optimization of the R1 and C1 values may be required for best transient performance.

Figure 13 illustrates the OPA2365 dual op amp providing signal conditioning within an ADS1258 bridge sensor circuit. It follows the ADS1258 16:1 multiplexer and is connected as a differential in/differential out amplifier. The voltage gain for this stage is approximately 10V/V. Driving the ADS1258 internal ADC in differential mode, rather than in a single-ended, exploits the full linearity performance capability of the converter. For best common-mode rejection the two R2 resistors should be closely matched.

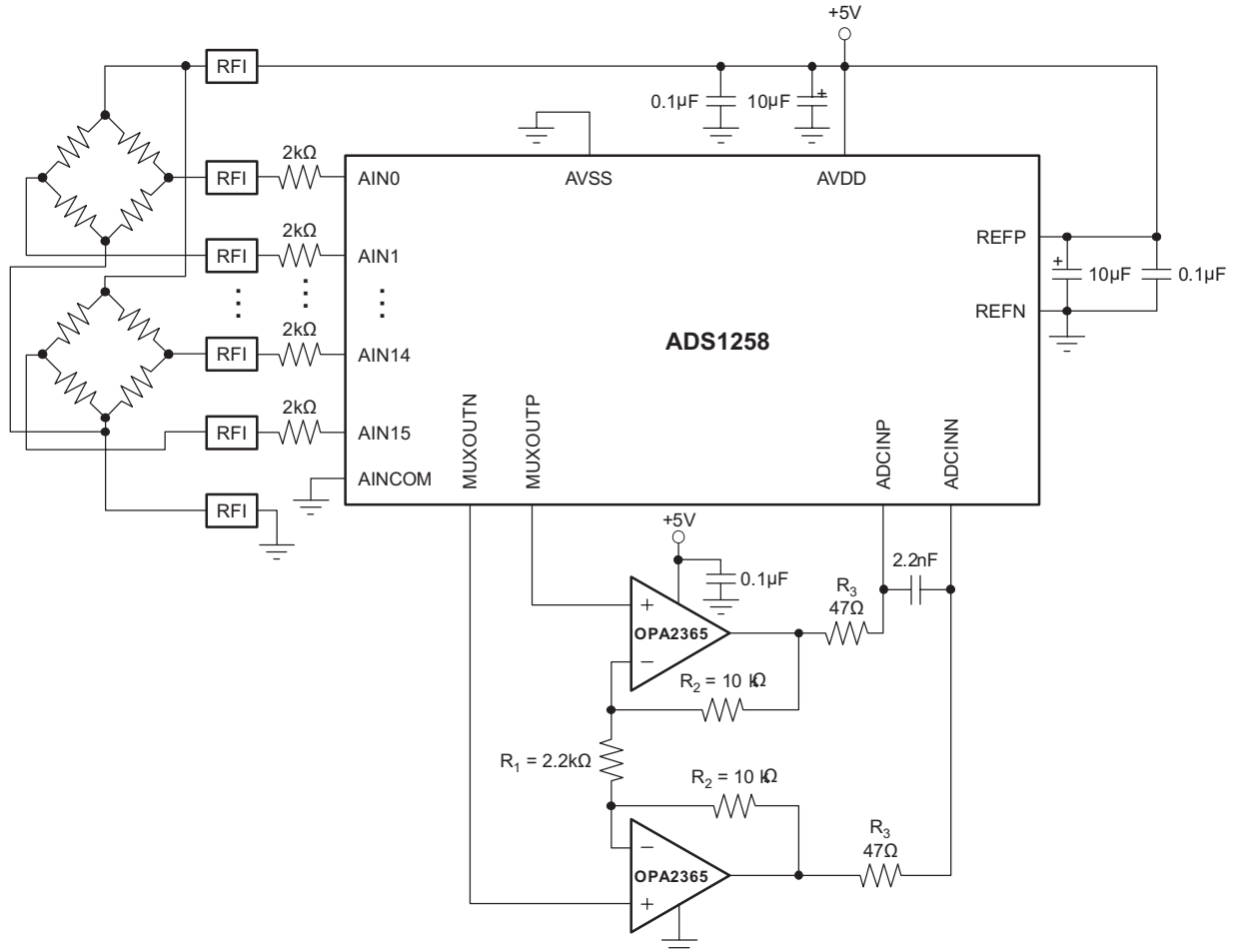

Figure 13. Conditioning Input Signals to the ADS1258 on a Single-Supply

Note that in Figure 13, the amplifiers, bridges, ADS1258, and internal reference are powered by the same single +5V supply. This ratiometric connection helps cancel excitation voltage drift effects and noise. For best performance, the +5V supply should be as free as possible of noise and transients.

When the ADS1258 data rate is set to maximum and the chop feature enabled, this circuit yields 12 bits of noise-free resolution with a 50mV full-scale input.

The chop feature is used to reduce the ADS1258 offset and offset drift to very low levels. A 2.2 nF capacitor is required across the ADC inputs to bypass the sampling currents. The 47Ω resistors provide isolation for the OPA2365 outputs from the relatively large, 2.2 nF capacitive load. For more information regarding the ADS1258, see the product data sheet available for download at www.ti.com.

REVISION HISTORY

Changes from Revision B (January 2012) to Revision C	Page
• Changed top-side marking to O2365Q	2
• Added another row with V_{OS} for OPA2365-Q1 only	3
• Changed I_Q upper limit to 5.3 from 5.5	4

PACKAGING INFORMATION

Orderable Device	Status (1)	Package Type	Package Drawing	Pins	Package Qty	Eco Plan (2)	Lead/Ball Finish	MSL Peak Temp (3)	Op Temp (°C)	Top-Side Markings (4)	Samples
OPA2365AQDRQ1	ACTIVE	SOIC	D	8	2500	Green (RoHS & no Sb/Br)	CU NIPDAU	Level-3-260C-168 HR	-40 to 125	O2365Q	Samples
OPA365AQDBVRQ1	ACTIVE	SOT-23	DBV	5	3000	Green (RoHS & no Sb/Br)	CU NIPDAU	Level-1-260C-UNLIM	-40 to 125	OTNQ	Samples

(1) The marketing status values are defined as follows:

ACTIVE: Product device recommended for new designs.

LIFEBUY: TI has announced that the device will be discontinued, and a lifetime-buy period is in effect.

NRND: Not recommended for new designs. Device is in production to support existing customers, but TI does not recommend using this part in a new design.

PREVIEW: Device has been announced but is not in production. Samples may or may not be available.

OBsolete: TI has discontinued the production of the device.

(2) Eco Plan - The planned eco-friendly classification: Pb-Free (RoHS), Pb-Free (RoHS Exempt), or Green (RoHS & no Sb/Br) - please check <http://www.ti.com/productcontent> for the latest availability information and additional product content details.

TBD: The Pb-Free/Green conversion plan has not been defined.

Pb-Free (RoHS): TI's terms "Lead-Free" or "Pb-Free" mean semiconductor products that are compatible with the current RoHS requirements for all 6 substances, including the requirement that lead not exceed 0.1% by weight in homogeneous materials. Where designed to be soldered at high temperatures, TI Pb-Free products are suitable for use in specified lead-free processes.

Pb-Free (RoHS Exempt): This component has a RoHS exemption for either 1) lead-based flip-chip solder bumps used between the die and package, or 2) lead-based die adhesive used between the die and leadframe. The component is otherwise considered Pb-Free (RoHS compatible) as defined above.

Green (RoHS & no Sb/Br): TI defines "Green" to mean Pb-Free (RoHS compatible), and free of Bromine (Br) and Antimony (Sb) based flame retardants (Br or Sb do not exceed 0.1% by weight in homogeneous material)

(3) MSL, Peak Temp. -- The Moisture Sensitivity Level rating according to the JEDEC industry standard classifications, and peak solder temperature.

(4) Multiple Top-Side Markings will be inside parentheses. Only one Top-Side Marking contained in parentheses and separated by a "~" will appear on a device. If a line is indented then it is a continuation of the previous line and the two combined represent the entire Top-Side Marking for that device.

Important Information and Disclaimer: The information provided on this page represents TI's knowledge and belief as of the date that it is provided. TI bases its knowledge and belief on information provided by third parties, and makes no representation or warranty as to the accuracy of such information. Efforts are underway to better integrate information from third parties. TI has taken and continues to take reasonable steps to provide representative and accurate information but may not have conducted destructive testing or chemical analysis on incoming materials and chemicals. TI and TI suppliers consider certain information to be proprietary, and thus CAS numbers and other limited information may not be available for release.

In no event shall TI's liability arising out of such information exceed the total purchase price of the TI part(s) at issue in this document sold by TI to Customer on an annual basis.

OTHER QUALIFIED VERSIONS OF OPA2365-Q1, OPA365-Q1 :

- Catalog: [OPA2365](#), [OPA365](#)
- Enhanced Product: [OPA365-EP](#)

NOTE: Qualified Version Definitions:

- Catalog - TI's standard catalog product
- Enhanced Product - Supports Defense, Aerospace and Medical Applications

TAPE AND REEL INFORMATION



QUADRANT ASSIGNMENTS FOR PIN 1 ORIENTATION IN TAPE



*All dimensions are nominal

Device	Package Type	Package Drawing	Pins	SPQ	Reel Diameter (mm)	Reel Width W1 (mm)	A0 (mm)	B0 (mm)	K0 (mm)	P1 (mm)	W (mm)	Pin1 Quadrant
OPA2365AQDRQ1	SOIC	D	8	2500	330.0	12.4	6.4	5.2	2.1	8.0	12.0	Q1
OPA365AQDBVRQ1	SOT-23	DBV	5	3000	179.0	8.4	3.2	3.2	1.4	4.0	8.0	Q3

TAPE AND REEL BOX DIMENSIONS

*All dimensions are nominal

Device	Package Type	Package Drawing	Pins	SPQ	Length (mm)	Width (mm)	Height (mm)
OPA2365AQDRQ1	SOIC	D	8	2500	367.0	367.0	35.0
OPA365AQDBVRQ1	SOT-23	DBV	5	3000	203.0	203.0	35.0

DBV (R-PDSO-G5)

PLASTIC SMALL-OUTLINE PACKAGE



- NOTES:
- A. All linear dimensions are in millimeters.
 - B. This drawing is subject to change without notice.
 - C. Body dimensions do not include mold flash or protrusion. Mold flash and protrusion shall not exceed 0.15 per side.
 - D. Falls within JEDEC MO-178 Variation AA.

DBV (R-PDSO-G5)

PLASTIC SMALL OUTLINE



- NOTES:
- A. All linear dimensions are in millimeters.
 - B. This drawing is subject to change without notice.
 - C. Customers should place a note on the circuit board fabrication drawing not to alter the center solder mask defined pad.
 - D. Publication IPC-7351 is recommended for alternate designs.
 - E. Laser cutting apertures with trapezoidal walls and also rounding corners will offer better paste release. Customers should contact their board assembly site for stencil design recommendations. Example stencil design based on a 50% volumetric metal load solder paste. Refer to IPC-7525 for other stencil recommendations.

D (R-PDSO-G8)

PLASTIC SMALL OUTLINE

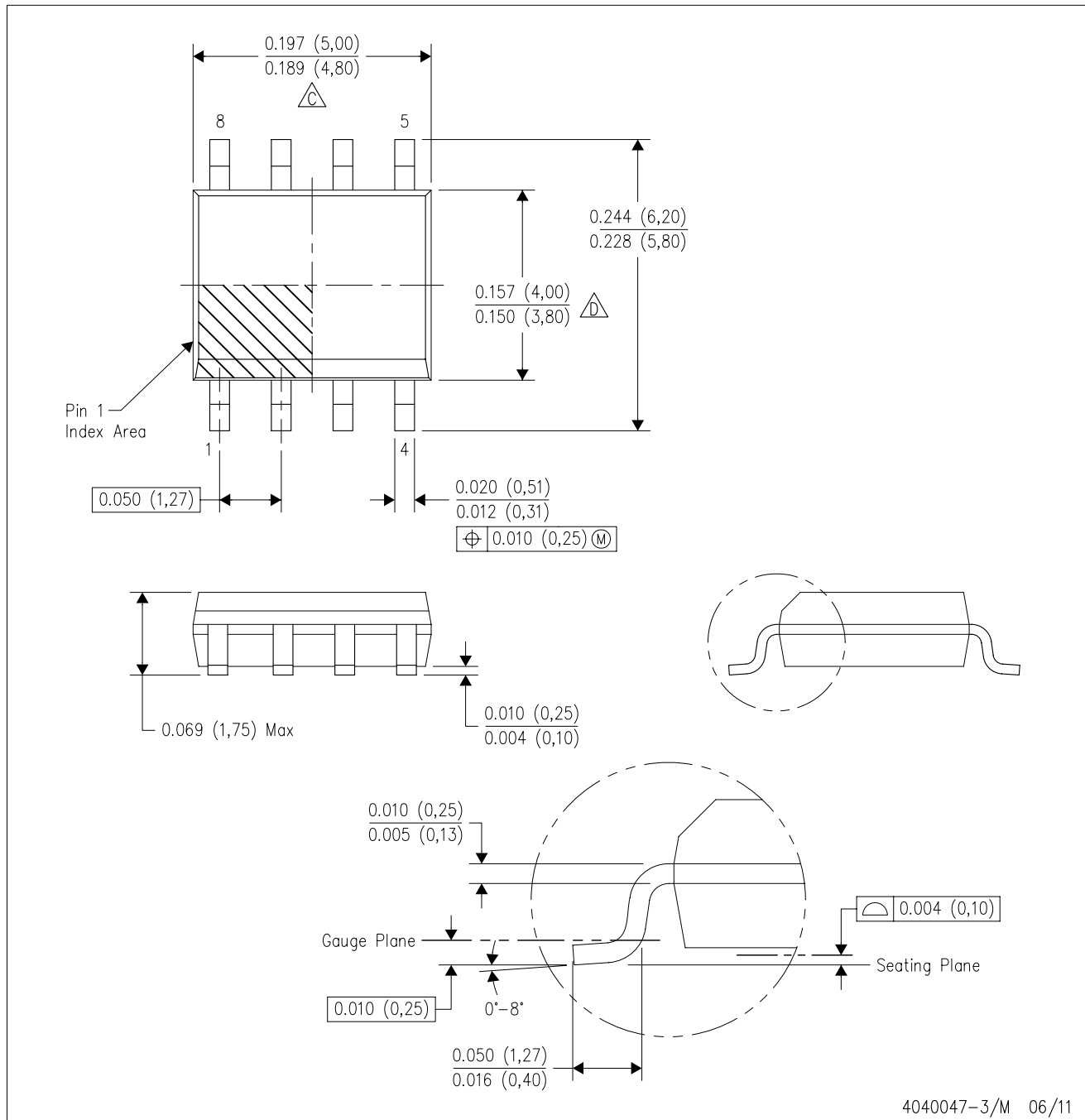

4040047-3/M 06/11

D (R-PDSO-G8)

PLASTIC SMALL OUTLINE

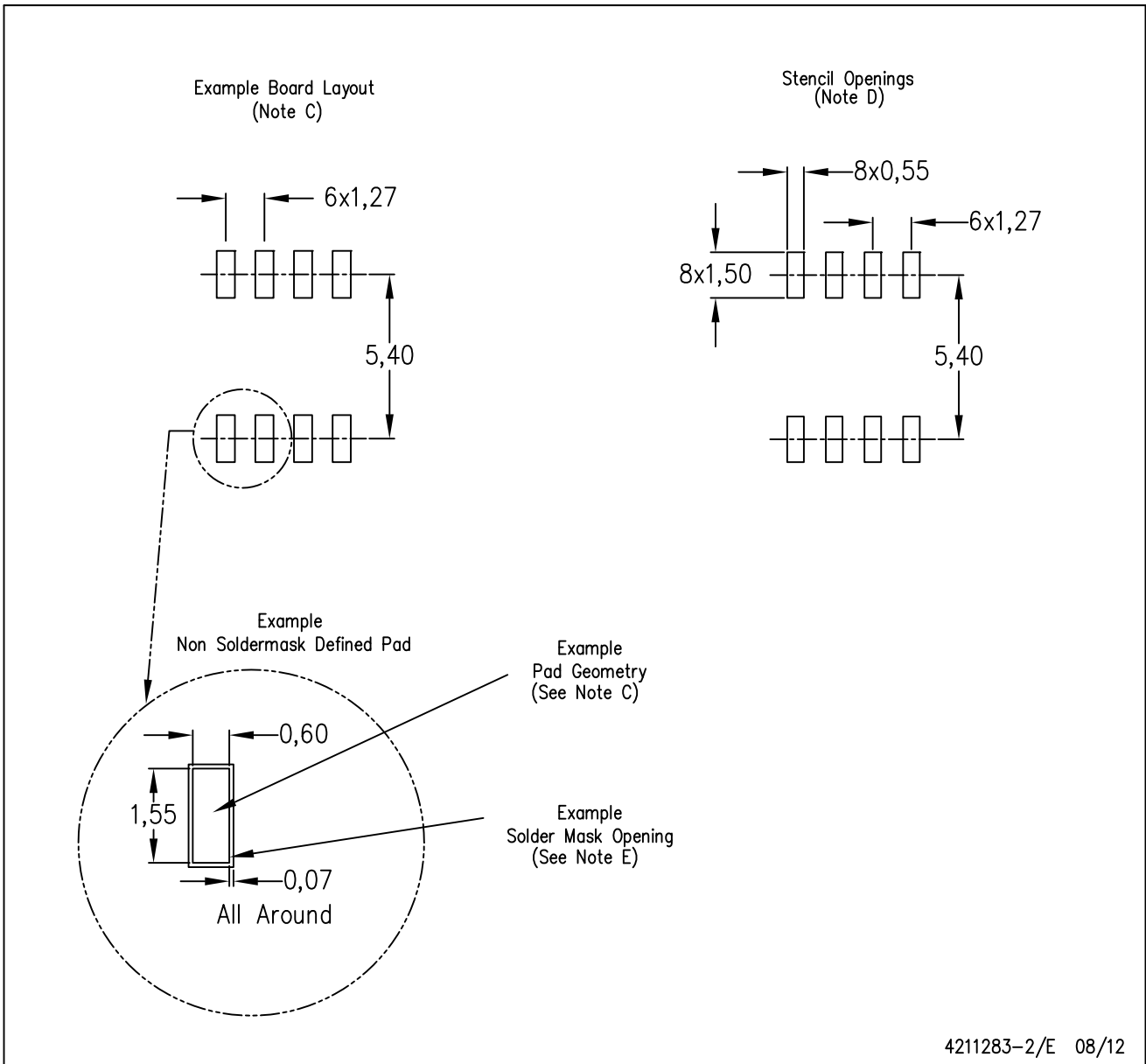

- NOTES:
- A. All linear dimensions are in millimeters.
 - B. This drawing is subject to change without notice.
 - C. Publication IPC-7351 is recommended for alternate designs.
 - D. Laser cutting apertures with trapezoidal walls and also rounding corners will offer better paste release. Customers should contact their board assembly site for stencil design recommendations. Refer to IPC-7525 for other stencil recommendations.
 - E. Customers should contact their board fabrication site for solder mask tolerances between and around signal pads.

IMPORTANT NOTICE

Texas Instruments Incorporated and its subsidiaries (TI) reserve the right to make corrections, enhancements, improvements and other changes to its semiconductor products and services per JESD46, latest issue, and to discontinue any product or service per JESD48, latest issue. Buyers should obtain the latest relevant information before placing orders and should verify that such information is current and complete. All semiconductor products (also referred to herein as "components") are sold subject to TI's terms and conditions of sale supplied at the time of order acknowledgment.

TI warrants performance of its components to the specifications applicable at the time of sale, in accordance with the warranty in TI's terms and conditions of sale of semiconductor products. Testing and other quality control techniques are used to the extent TI deems necessary to support this warranty. Except where mandated by applicable law, testing of all parameters of each component is not necessarily performed.

TI assumes no liability for applications assistance or the design of Buyers' products. Buyers are responsible for their products and applications using TI components. To minimize the risks associated with Buyers' products and applications, Buyers should provide adequate design and operating safeguards.

TI does not warrant or represent that any license, either express or implied, is granted under any patent right, copyright, mask work right, or other intellectual property right relating to any combination, machine, or process in which TI components or services are used. Information published by TI regarding third-party products or services does not constitute a license to use such products or services or a warranty or endorsement thereof. Use of such information may require a license from a third party under the patents or other intellectual property of the third party, or a license from TI under the patents or other intellectual property of TI.

Reproduction of significant portions of TI information in TI data books or data sheets is permissible only if reproduction is without alteration and is accompanied by all associated warranties, conditions, limitations, and notices. TI is not responsible or liable for such altered documentation. Information of third parties may be subject to additional restrictions.

Resale of TI components or services with statements different from or beyond the parameters stated by TI for that component or service voids all express and any implied warranties for the associated TI component or service and is an unfair and deceptive business practice. TI is not responsible or liable for any such statements.

Buyer acknowledges and agrees that it is solely responsible for compliance with all legal, regulatory and safety-related requirements concerning its products, and any use of TI components in its applications, notwithstanding any applications-related information or support that may be provided by TI. Buyer represents and agrees that it has all the necessary expertise to create and implement safeguards which anticipate dangerous consequences of failures, monitor failures and their consequences, lessen the likelihood of failures that might cause harm and take appropriate remedial actions. Buyer will fully indemnify TI and its representatives against any damages arising out of the use of any TI components in safety-critical applications.

In some cases, TI components may be promoted specifically to facilitate safety-related applications. With such components, TI's goal is to help enable customers to design and create their own end-product solutions that meet applicable functional safety standards and requirements. Nonetheless, such components are subject to these terms.

No TI components are authorized for use in FDA Class III (or similar life-critical medical equipment) unless authorized officers of the parties have executed a special agreement specifically governing such use.

Only those TI components which TI has specifically designated as military grade or "enhanced plastic" are designed and intended for use in military/aerospace applications or environments. Buyer acknowledges and agrees that any military or aerospace use of TI components which have **not** been so designated is solely at the Buyer's risk, and that Buyer is solely responsible for compliance with all legal and regulatory requirements in connection with such use.

TI has specifically designated certain components as meeting ISO/TS16949 requirements, mainly for automotive use. In any case of use of non-designated products, TI will not be responsible for any failure to meet ISO/TS16949.

Products

Audio	www.ti.com/audio
Amplifiers	amplifier.ti.com
Data Converters	dataconverter.ti.com
DLP® Products	www.dlp.com
DSP	dsp.ti.com
Clocks and Timers	www.ti.com/clocks
Interface	interface.ti.com
Logic	logic.ti.com
Power Mgmt	power.ti.com
Microcontrollers	microcontroller.ti.com
RFID	www.ti-rfid.com
OMAP Applications Processors	www.ti.com/omap
Wireless Connectivity	www.ti.com/wirelessconnectivity

Applications

Automotive and Transportation	www.ti.com/automotive
Communications and Telecom	www.ti.com/communications
Computers and Peripherals	www.ti.com/computers
Consumer Electronics	www.ti.com/consumer-apps
Energy and Lighting	www.ti.com/energy
Industrial	www.ti.com/industrial
Medical	www.ti.com/medical
Security	www.ti.com/security
Space, Avionics and Defense	www.ti.com/space-avionics-defense
Video and Imaging	www.ti.com/video

TI E2E Community

e2e.ti.com