



# 50MHz, Low-Distortion, High CMRR, RRI/O, Single-Supply OPERATIONAL AMPLIFIER

## FEATURES

- **GAIN BANDWIDTH: 50MHz**
- **ZERO-CROSSOVER DISTORTION TOPOLOGY:**
  - Excellent THD+N: 0.0004%
  - CMRR: 100dB (min)
  - Rail-to-Rail Input and Output
    - Input 100mV Beyond Supply Rail
- **LOW NOISE: 4.5nV/√Hz at 100kHz**
- **SLEW RATE: 25V/μs**
- **FAST SETTling: 0.3μs to 0.01%**
- **PRECISION:**
  - Low Offset: 100μV
  - Low Input Bias Current: 0.2pA
- **2.2V TO 5.5V OPERATION**

## APPLICATIONS

- SIGNAL CONDITIONING
- DATA ACQUISITION
- PROCESS CONTROL
- ACTIVE FILTERS
- TEST EQUIPMENT
- AUDIO
- WIDEBAND AMPLIFIERS

## DESCRIPTION

The OPAX365 zero-crossover series, rail-to-rail, high-performance, CMOS operational amplifiers are optimized for very low voltage, single-supply applications. Rail-to-rail input/output, low-noise (4.5nV/√Hz) and high-speed operation (50MHz Gain Bandwidth) make these devices ideal for driving sampling analog-to-digital converters (ADCs). Applications include audio, signal conditioning, and sensor amplification. The OPA365 family of op amps are also well-suited for cell phone power amplifier control loops.

Special features include an excellent common-mode rejection ratio (CMRR), no input stage crossover distortion, high input impedance, and rail-to-rail input and output swing. The input common-mode range includes both the negative and positive supplies. The output voltage swing is within 10mV of the rails.

The OPA365 (single version) is available in the *micro-SIZE* SOT23-5 and SO-8 packages. The OPA2365 (dual version) is offered in the SO-8 package. All versions are specified for operation from –40°C to +125°C. Single and dual versions have identical specifications for maximum design flexibility.

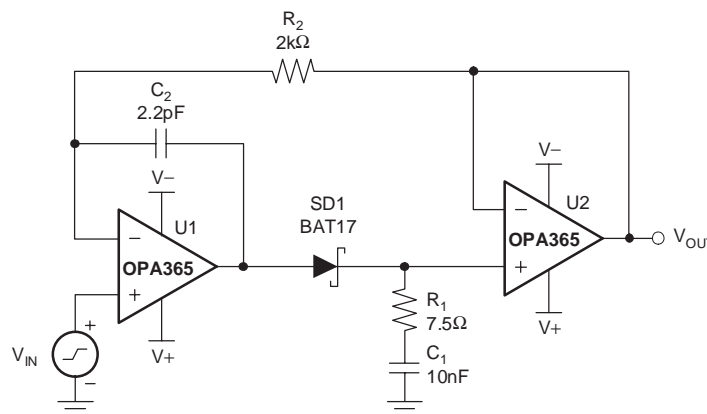

**Fast Settling Peak Detector**



Please be aware that an important notice concerning availability, standard warranty, and use in critical applications of Texas Instruments semiconductor products and disclaimers thereto appears at the end of this data sheet.

All trademarks are the property of their respective owners.

**ABSOLUTE MAXIMUM RATINGS(1)**

Supply Voltage	+5.5V
Signal Input Terminals, Voltage <sup>(2)</sup>	(V-) -0.5V to (V+) + 0.5V
Signal Input Terminals, Current <sup>(2)</sup>	±10mA
Output Short-Circuit <sup>(3)</sup>	Continuous
Operating Temperature	-40°C to +150°C
Storage Temperature	-65°C to +150°C
Junction Temperature	+150°C
<b>ESD Rating</b>	
Human Body Model	4000V
Charged Device Model	1000V
Machine Model	400V



This integrated circuit can be damaged by ESD. Texas Instruments recommends that all integrated circuits be handled with appropriate precautions. Failure to observe proper handling and installation procedures can cause damage.

ESD damage can range from subtle performance degradation to complete device failure. Precision integrated circuits may be more susceptible to damage because very small parametric changes could cause the device not to meet its published specifications.

- (1) Stresses above these ratings may cause permanent damage. Exposure to absolute maximum conditions for extended periods may degrade device reliability. These are stress ratings only, and functional operation of the device at these or any other conditions beyond those specified is not supported.
- (2) Input terminals are diode-clamped to the power-supply rails. Input signals that can swing more than 0.5V beyond the supply rails should be current limited to 10mA or less.
- (3) Short-circuit to ground, one amplifier per package.

**ORDERING INFORMATION(1)**

PRODUCT	PACKAGE-LEAD	PACKAGE DESIGNATOR	PACKAGE MARKING
OPA365	SOT23-5	DBV	OAVQ
	SO-8	D	O365A
OPA2365	SO-8	D	O2365A

(1) For the most current package and ordering information, see the Package Option Addendum at the end of this document, or see the TI web site at www.ti.com.

**PIN CONFIGURATIONS**

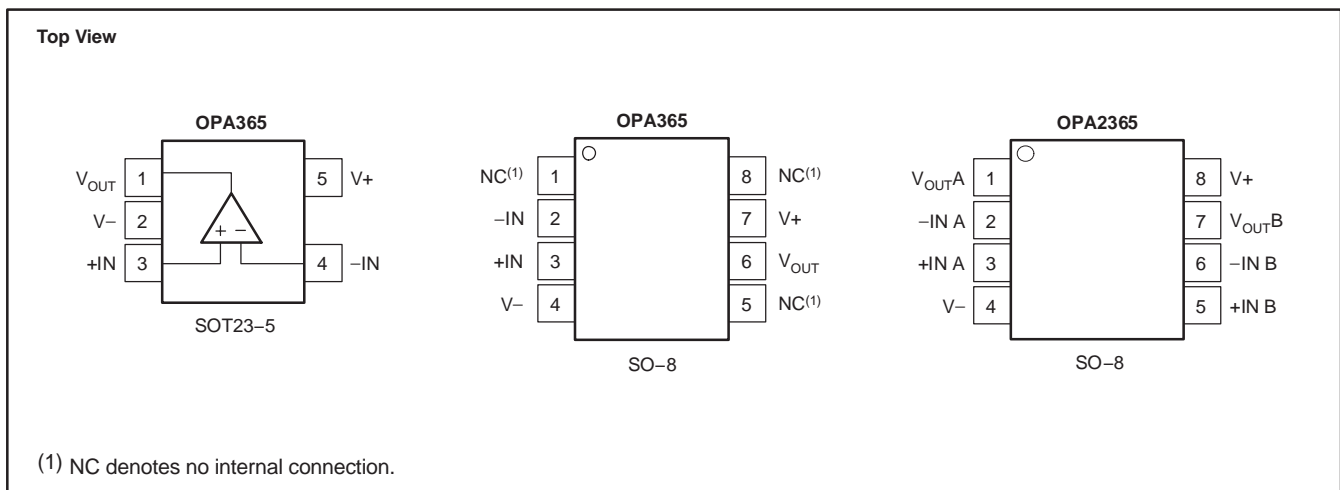

**ELECTRICAL CHARACTERISTICS:  $V_S = +2.2V$  to  $+5.5V$** 
**Boldface** limits apply over the specified temperature range,  $T_A = -40^\circ\text{C}$  to  $+125^\circ\text{C}$ .

 At  $T_A = +25^\circ\text{C}$ ,  $R_L = 10\text{k}\Omega$  connected to  $V_S/2$ ,  $V_{CM} = V_S/2$ , and  $V_{OUT} = V_S/2$ , unless otherwise noted.

PARAMETER	TEST CONDITIONS	OPAx365			UNIT
		MIN	TYP	MAX	
<b>OFFSET VOLTAGE</b>					
Input Offset Voltage	$V_{OS}$		100	200	$\mu\text{V}$
<b>Drift</b>	$dV_{OS}/dT$		<b>1</b>		$\mu\text{V}/^\circ\text{C}$
<b>vs Power Supply</b>	<b>PSRR</b>		<b>10</b>	<b>100</b>	$\mu\text{V}/\text{V}$
Channel Separation, dc	$V_S = +2.2V$ to $+5.5V$		0.2		$\mu\text{V}/\text{V}$
<b>INPUT BIAS CURRENT</b>					
Input Bias Current	$I_B$		$\pm 0.2$	$\pm 10$	$\text{pA}$
<b>over Temperature</b>			See Typical Characteristics		
Input Offset Current	$I_{OS}$		$\pm 0.2$	$\pm 10$	$\text{pA}$
<b>NOISE</b>					
Input Voltage Noise, $f = 0.1\text{Hz}$ to $10\text{Hz}$	$e_n$		5		$\mu\text{V}_{pp}$
Input Voltage Noise Density, $f = 100\text{kHz}$	$e_n$		4.5		$\text{nV}/\sqrt{\text{Hz}}$
Input Current Noise Density, $f = 10\text{kHz}$	$i_n$		4		$\text{fA}/\sqrt{\text{Hz}}$
<b>INPUT VOLTAGE RANGE</b>					
Common-Mode Voltage Range	$V_{CM}$		$(V-) - 0.1$	$(V+) + 0.1$	$\text{V}$
<b>Common-Mode Rejection Ratio</b>	<b>CMRR</b>	$(V-) - 0.1\text{V} \leq V_{CM} \leq (V+) + 0.1\text{V}$	<b>100</b>	<b>120</b>	<b>dB</b>
<b>INPUT CAPACITANCE</b>					
Differential			6		$\text{pF}$
Common-Mode			2		$\text{pF}$
<b>OPEN-LOOP GAIN</b>					
<b>Open-Loop Voltage Gain</b>	$A_{OL}$	$R_L = 10\text{k}\Omega$ , $100\text{mV} < V_O < (V+) - 100\text{mV}$	<b>100</b>	<b>120</b>	<b>dB</b>
		$R_L = 600\Omega$ , $200\text{mV} < V_O < (V+) - 200\text{mV}$	100	120	dB
		$R_L = 600\Omega$ , $200\text{mV} < V_O < (V+) - 200\text{mV}$	<b>94</b>		<b>dB</b>
<b>FREQUENCY RESPONSE</b>					
Gain-Bandwidth Product	GBW	$V_S = 5V$		50	MHz
Slew Rate	SR	$G = +1$		25	$\text{V}/\mu\text{s}$
Settling Time, 0.1%	$t_S$	4V Step, $G = +1$		200	ns
0.01%		4V Step, $G = +1$		300	ns
Overload Recovery Time		$V_{IN} \times \text{Gain} > V_S$		$< 0.1$	$\mu\text{s}$
Total Harmonic Distortion + Noise <sup>(1)</sup>	THD+N	$R_L = 600\Omega$ , $V_O = 4V_{pp}$ , $G = +1$ , $f = 1\text{kHz}$		0.0004	%
<b>OUTPUT</b>					
Voltage Output Swing from Rail		$R_L = 10\text{k}\Omega$ , $V_S = 5.5V$		<b>10</b>	<b>mV</b>
<b>over Temperature</b>				$\pm 65$	<b>mA</b>
Short-Circuit Current	$I_{SC}$			See Typical Characteristics	
Capacitive Load Drive	$C_L$	$f = 1\text{MHz}$ , $I_O = 0$		30	$\Omega$
Open-Loop Output Impedance					
<b>POWER SUPPLY</b>					
Specified Voltage Range	$V_S$		2.2	5.5	$\text{V}$
Quiescent Current Per Amplifier	$I_Q$	$I_O = 0$		4.6	$\text{mA}$
<b>over Temperature</b>				<b>5</b>	<b>mA</b>
<b>TEMPERATURE RANGE</b>					
Specified Range			-40	+125	$^\circ\text{C}$
Thermal Resistance	$\theta_{JA}$				$^\circ\text{C}/\text{W}$
SOT23-5				200	$^\circ\text{C}/\text{W}$
SO-8				150	$^\circ\text{C}/\text{W}$

(1) 3rd-order filter; bandwidth 80kHz at -3dB.

TYPICAL CHARACTERISTICS

At  $T_A = +25^\circ\text{C}$ ,  $V_S = +5\text{V}$ , and  $C_L = 0\text{pF}$ , unless otherwise noted.

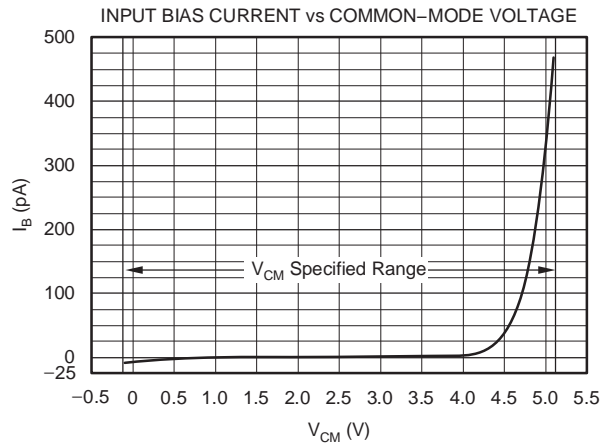
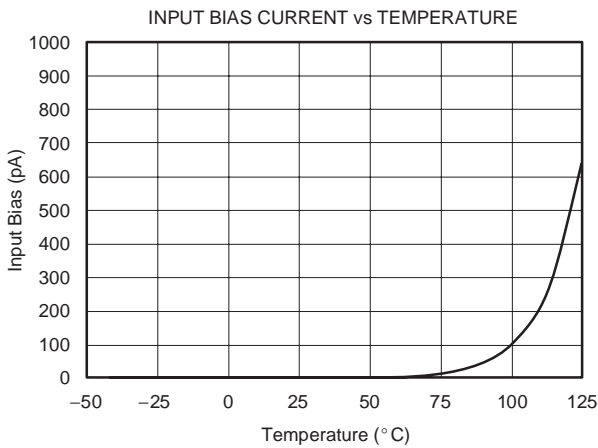
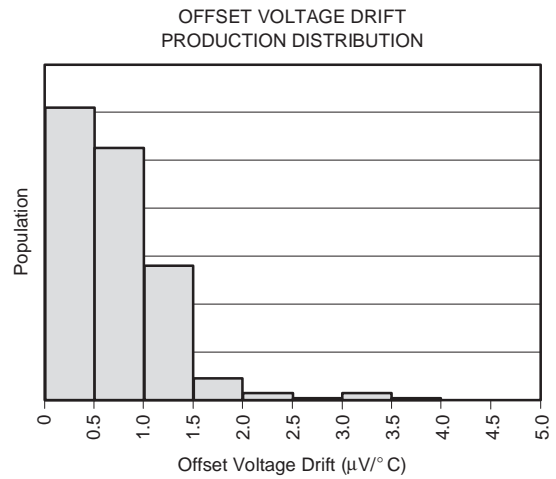
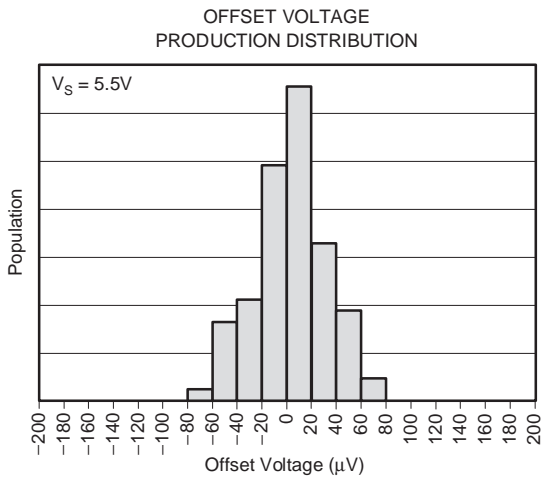
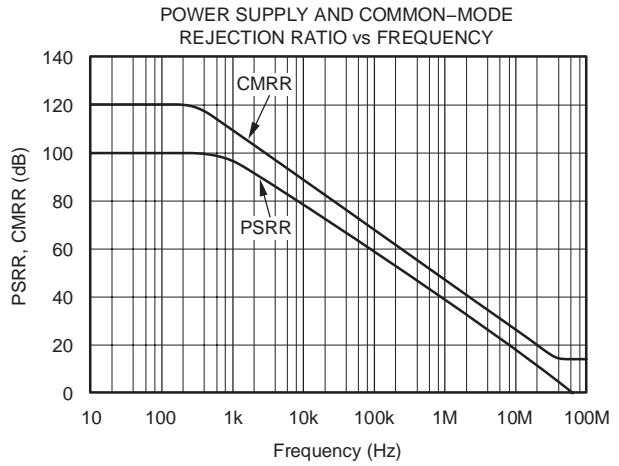
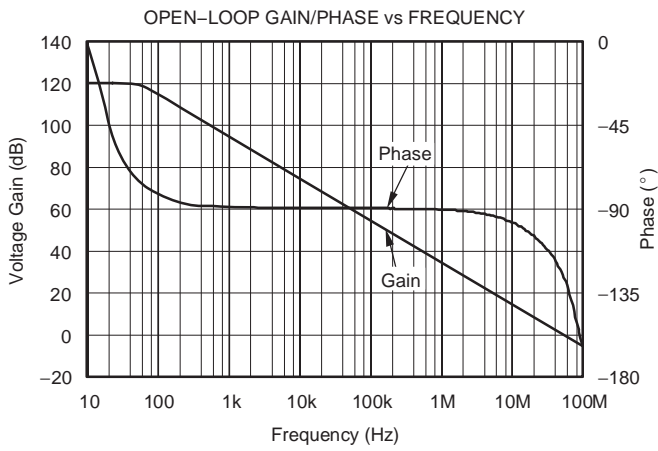

**TYPICAL CHARACTERISTICS (continued)**

At  $T_A = +25^\circ\text{C}$ ,  $V_S = +5\text{V}$ , and  $C_L = 0\text{pF}$ , unless otherwise noted.

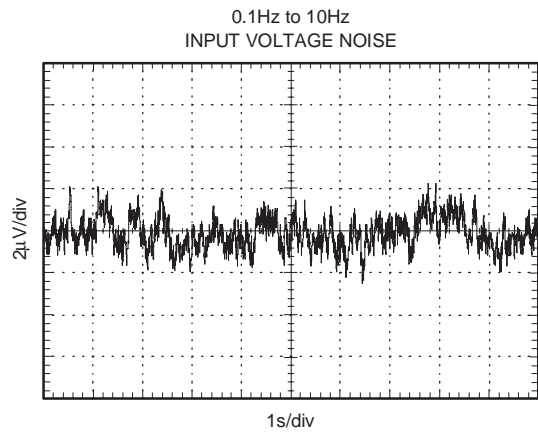
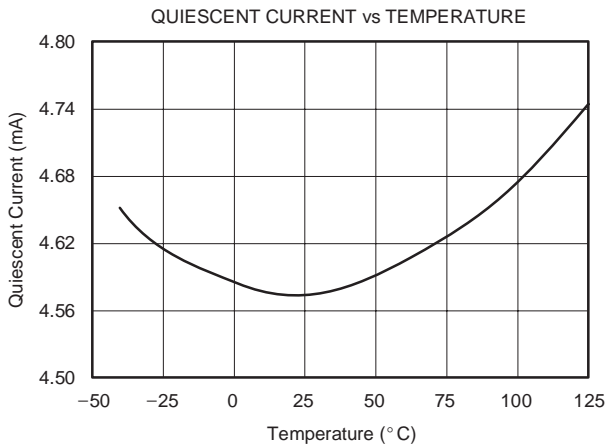
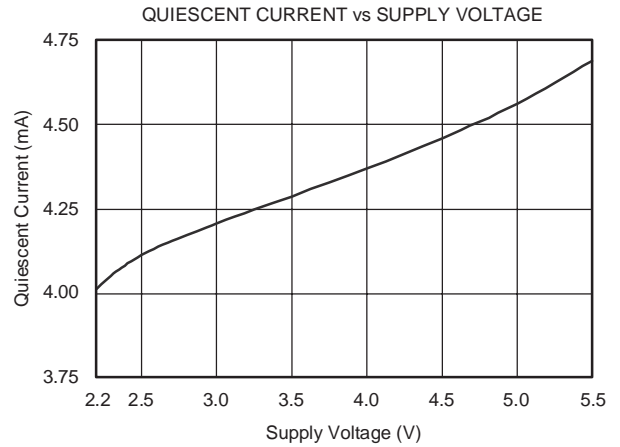
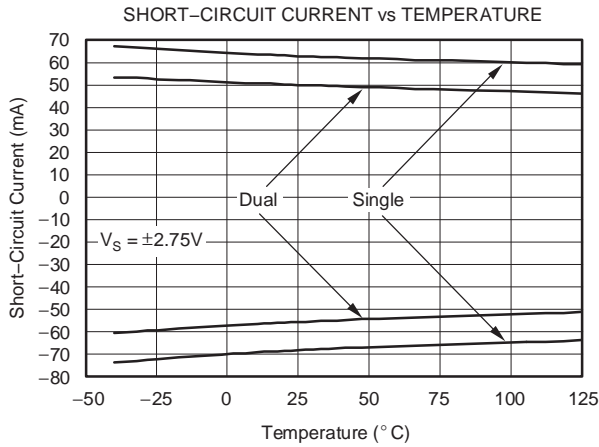
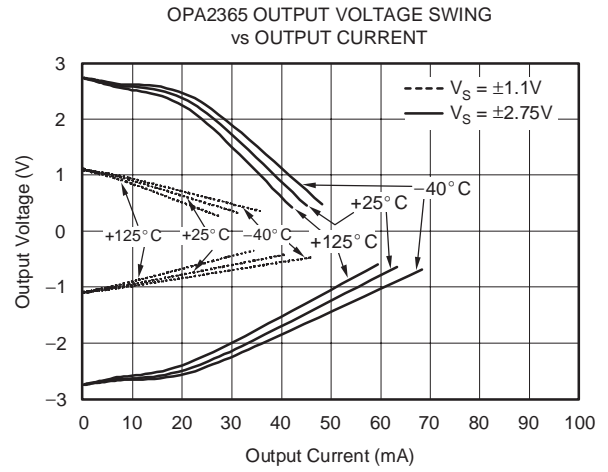
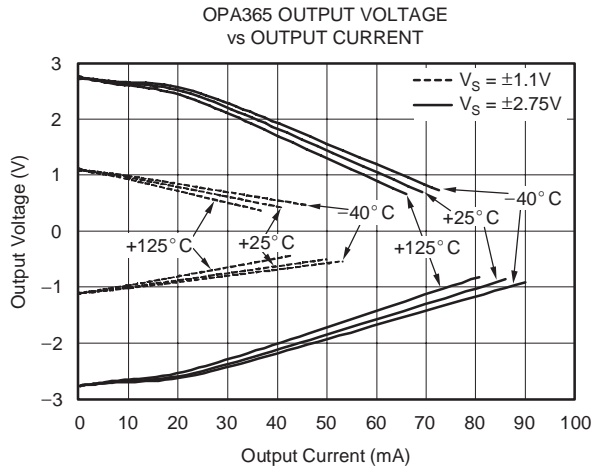

**TYPICAL CHARACTERISTICS (continued)**

At  $T_A = +25^\circ\text{C}$ ,  $V_S = +5\text{V}$ , and  $C_L = 0\text{pF}$ , unless otherwise noted.

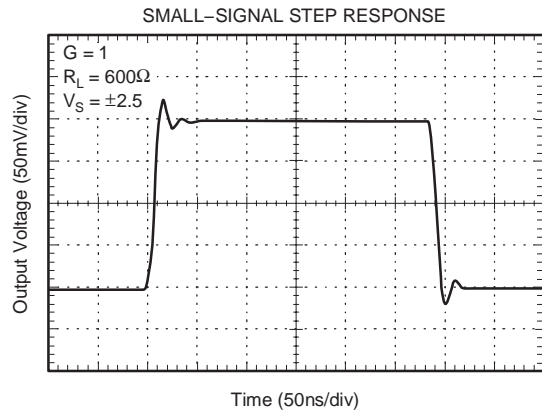
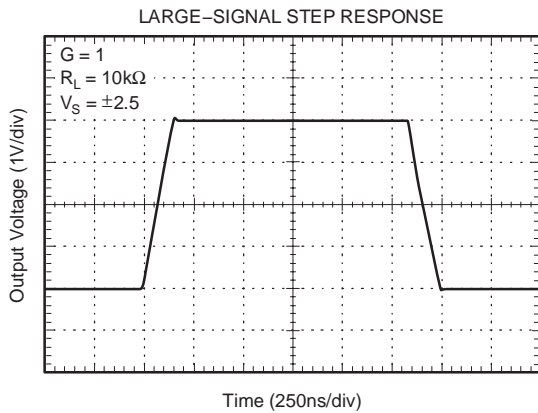
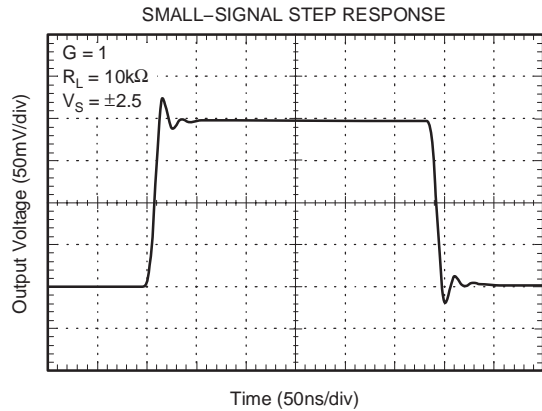
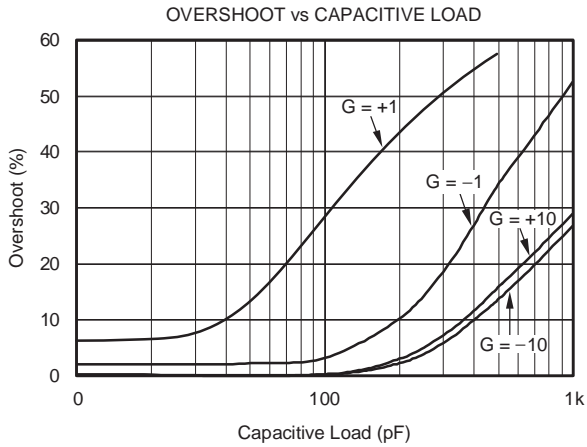
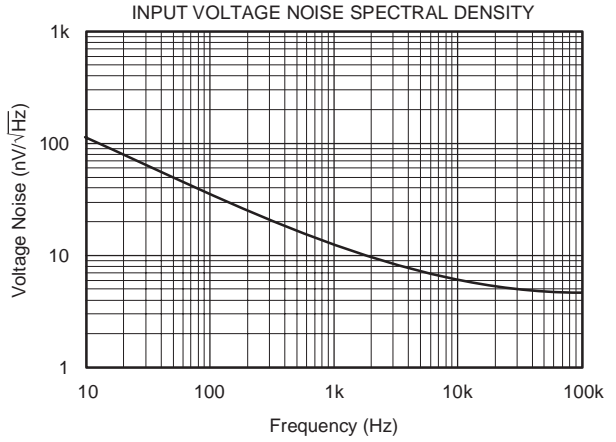
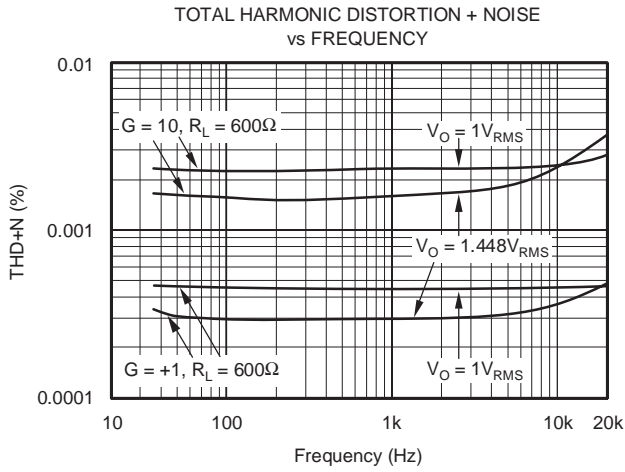

## TYPICAL CHARACTERISTICS (continued)

At  $T_A = +25^\circ\text{C}$ ,  $V_S = +5\text{V}$ , and  $C_L = 0\text{pF}$ , unless otherwise noted.

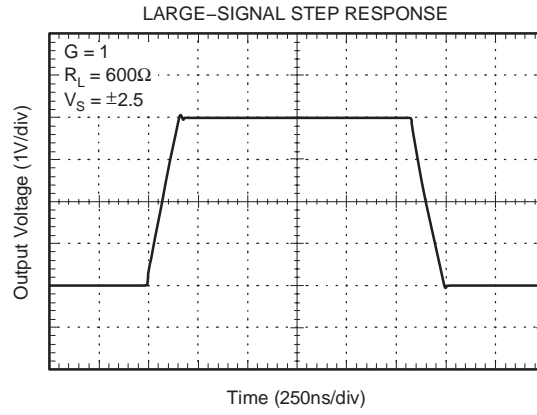

## APPLICATIONS INFORMATION

### OPERATING CHARACTERISTICS

The OPA365 amplifier parameters are fully specified from +2.2V to +5.5V. Many of the specifications apply from  $-40^{\circ}\text{C}$  to  $+125^{\circ}\text{C}$ . Parameters that can exhibit significant variance with regard to operating voltage or temperature are presented in the Typical Characteristics.

### GENERAL LAYOUT GUIDELINES

The OPA365 is a wideband amplifier. To realize the full operational performance of the device, good high-frequency printed circuit board (PCB) layout practices are required. Low-loss,  $0.1\mu\text{F}$  bypass capacitors must be connected between each supply pin and ground as close to the device as possible. The bypass capacitor traces should be designed for minimum inductance.

### BASIC AMPLIFIER CONFIGURATIONS

As with other single-supply op amps, the OPA365 may be operated with either a single supply or dual supplies. A typical dual-supply connection is shown in Figure 1, which is accompanied by a single-supply connection. The OPA365 is configured as a basic inverting amplifier with a gain of  $-10\text{V/V}$ . The dual-supply connection has an output voltage centered on zero, while the single-supply connection has an output centered on the common-mode voltage  $V_{\text{CM}}$ . For the circuit shown, this voltage is 1.5V, but may be any value within the common-mode input voltage range. The OPA365  $V_{\text{CM}}$  range extends 100mV beyond the power-supply rails.

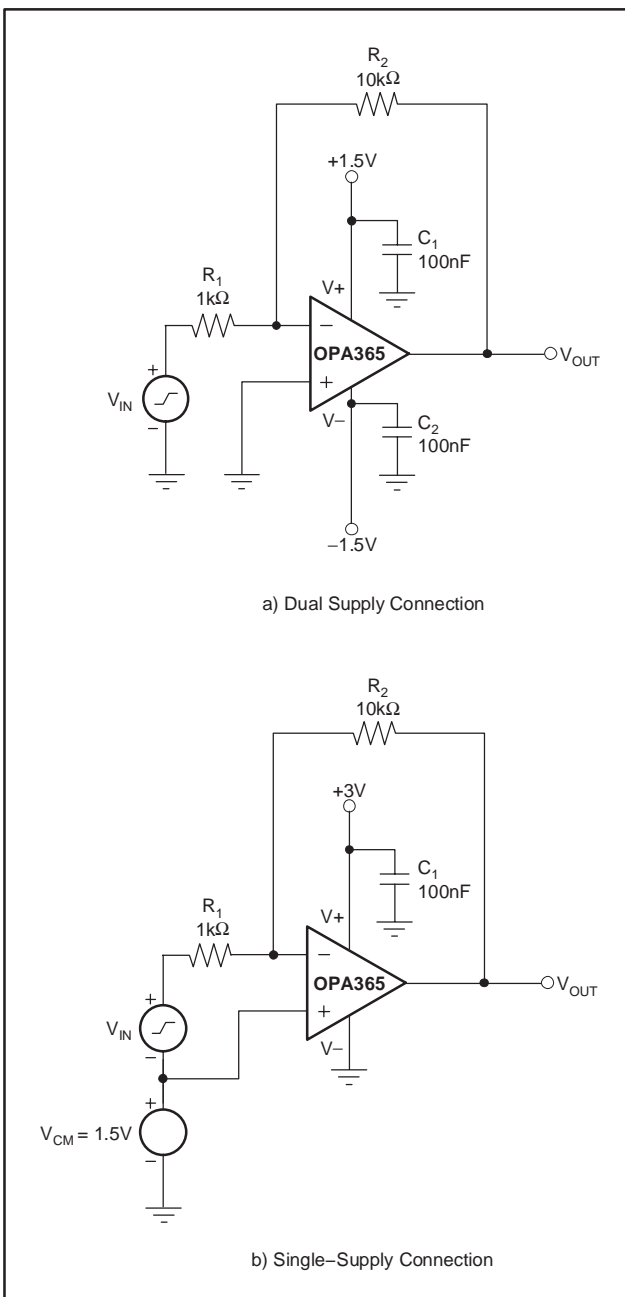

Figure 1. Basic Circuit Connections

Figure 2 shows a single-supply, electret microphone application where  $V_{CM}$  is provided by a resistive divider. The divider also provides the bias voltage for the electret element.

### INPUT AND ESD PROTECTION

The OPA365 incorporates internal electrostatic discharge (ESD) protection circuits on all pins. In the case of input and output pins, this protection primarily consists of current steering diodes connected between the input and power-supply pins. These ESD protection diodes also provide in-circuit, input overdrive protection, provided that the current is limited to 10mA as stated in the Absolute Maximum Ratings. Figure 3 shows how a series input resistor may be added to the driven input to limit the input current. The added resistor contributes thermal noise at the amplifier input and its value should be kept to the minimum in noise-sensitive applications.

### RAIL-TO-RAIL INPUT

The OPA365 product family features true rail-to-rail input operation, with supply voltages as low as  $\pm 1.1V$  (2.2V). A unique zero-crossover input topology eliminates the input offset transition region typical of many rail-to-rail, complementary stage operational amplifiers. This topology also allows the OPA365 to provide superior common-mode performance over the entire input range, which extends 100mV beyond both power-supply rails, as shown in Figure 4. When driving ADCs, the highly linear  $V_{CM}$  range of the OPA365 assures that the op amp/ADC system linearity performance is not compromised.

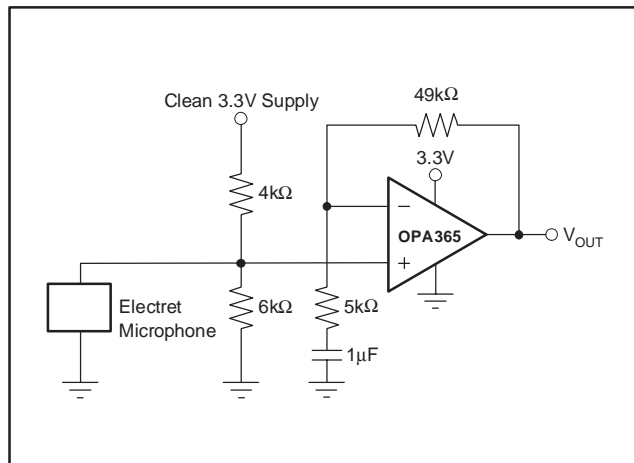

**Figure 2. Microphone Preamplifier**

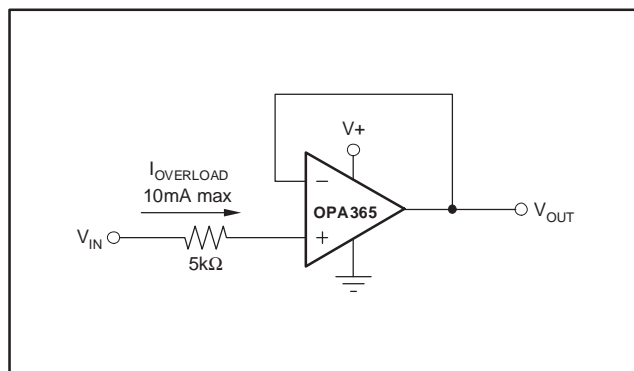

**Figure 3. Input Current Protection**

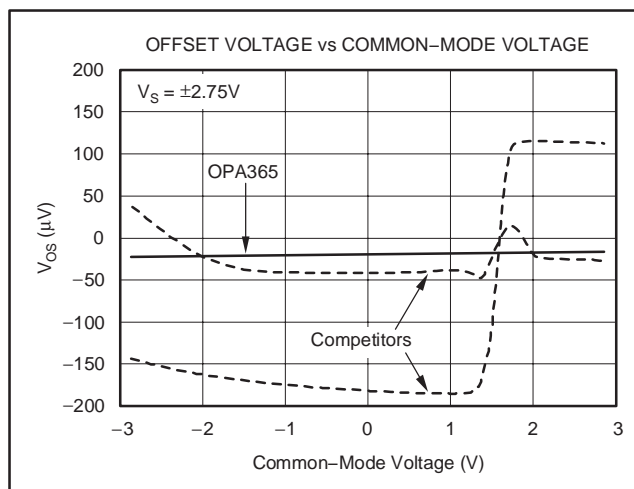

**Figure 4. OPA365 has Linear Offset Over the Entire Common-Mode Range**

A simplified schematic illustrating the rail-to-rail input circuitry is shown in Figure 5.

### CAPACITIVE LOADS

The OPA365 may be used in applications where driving a capacitive load is required. As with all op amps, there may be specific instances where the OPA365 can become unstable, leading to oscillation. The particular op amp circuit configuration, layout, gain and output loading are some of the factors to consider when establishing whether an amplifier will be stable in operation. An op amp in the unity-gain (+1V/V) buffer configuration and driving a capacitive load exhibits a greater tendency to be unstable than an amplifier operated at a higher noise gain. The capacitive load, in conjunction with the op amp output resistance, creates a pole within the feedback loop that degrades the phase margin. The degradation of the phase margin increases as the capacitive loading increases.

When operating in the unity-gain configuration, the OPA365 remains stable with a pure capacitive load up to approximately 1nF. The equivalent series resistance (ESR) of some very large capacitors ( $C_L > 1\mu\text{F}$ ) is sufficient to alter the phase characteristics in the feedback loop such that the amplifier remains stable. Increasing the amplifier closed-loop gain allows the amplifier to drive increasingly larger capacitance. This increased capability is evident when observing the overshoot response of the amplifier at higher voltage gains. See the typical characteristic graph, *Small-Signal Overshoot vs. Capacitive Load*.

One technique for increasing the capacitive load drive capability of the amplifier operating in unity gain is to insert a small resistor, typically  $10\Omega$  to  $20\Omega$ , in series with the output; see Figure 6. This resistor significantly reduces the overshoot and ringing associated with large capacitive loads. A possible problem with this technique is that a voltage divider is created with the added series resistor and any resistor connected in parallel with the capacitive load. The voltage divider introduces a gain error at the output that reduces the output swing. The error contributed by the voltage divider may be insignificant. For instance, with a load resistance,  $R_L = 10\text{k}\Omega$ , and  $R_S = 20\Omega$ , the gain error is only about 0.2%. However, when  $R_L$  is decreased to  $600\Omega$ , which the OPA365 is able to drive, the error increases to 7.5%.

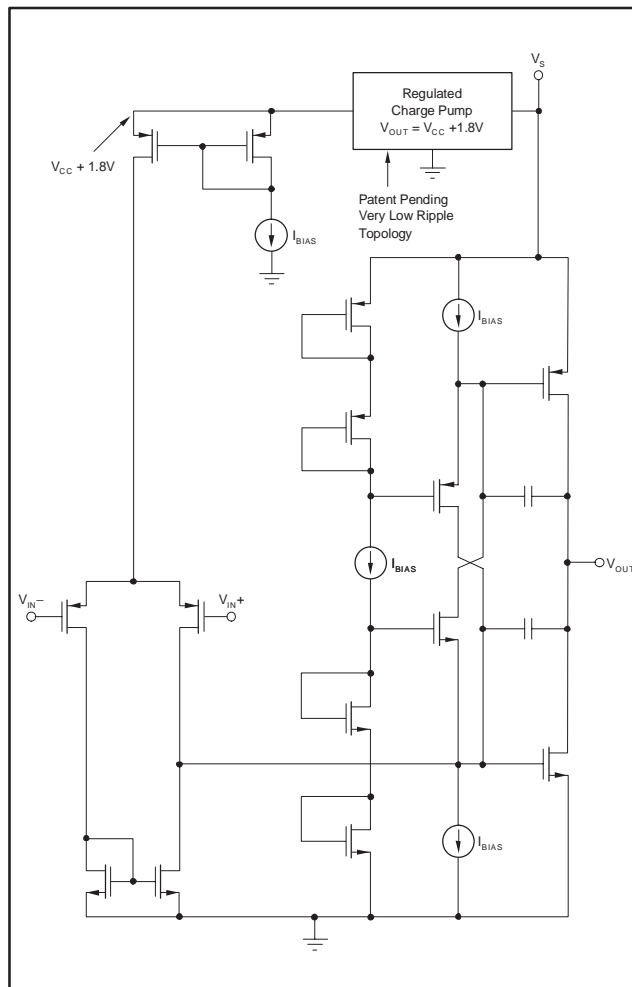

Figure 5. Simplified Schematic

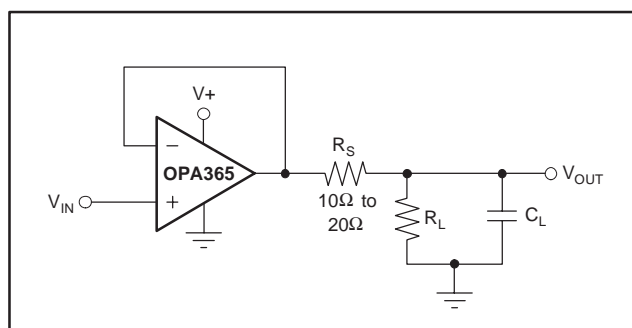

Figure 6. Improving Capacitive Load Drive

### ACHIEVING AN OUTPUT LEVEL OF ZERO VOLTS (0V)

Certain single-supply applications require the op amp output to swing from 0V to a positive full-scale voltage and have high accuracy. An example is an op amp employed to drive a single-supply ADC having an input range from 0V to +5V. Rail-to-rail output amplifiers with very light output loading may achieve an output level within millivolts of 0V (or +V<sub>S</sub> at the high end), but not 0V. Furthermore, the deviation from 0V only becomes greater as the load current required increases. This increased deviation is a result of limitations of the CMOS output stage.

When a pull-down resistor is connected from the amplifier output to a negative voltage source, the OPA365 can achieve an output level of 0V, and even a few millivolts below 0V. Below this limit, nonlinearity and limiting conditions become evident. Figure 7 illustrates a circuit using this technique.

A pull-down current of approximately 500μA is required when OPA365 is connected as a unity-gain buffer. A practical termination voltage (V<sub>NEG</sub>) is -5V, but other convenient negative voltages also may be used. The pull-down resistor R<sub>L</sub> is calculated from  $R_L = [(V_O - V_{NEG}) / (500\mu A)]$ . Using a minimum output voltage (V<sub>O</sub>) of 0V,  $R_L = [0V - (-5V)] / (500\mu A) = 10k\Omega$ . Keep in mind that lower termination voltages result in smaller pull-down resistors that load the output during positive output voltage excursions.

Note that this technique does not work with all op amps and should only be applied to op amps such as the OPA365 that have been specifically designed to operate in this manner. Also, operating the OPA365 output at 0V changes the output stage operating conditions, resulting in somewhat lower open-loop gain and bandwidth. Keep these precautions in mind when driving a capacitive load because these conditions can affect circuit transient response and stability.

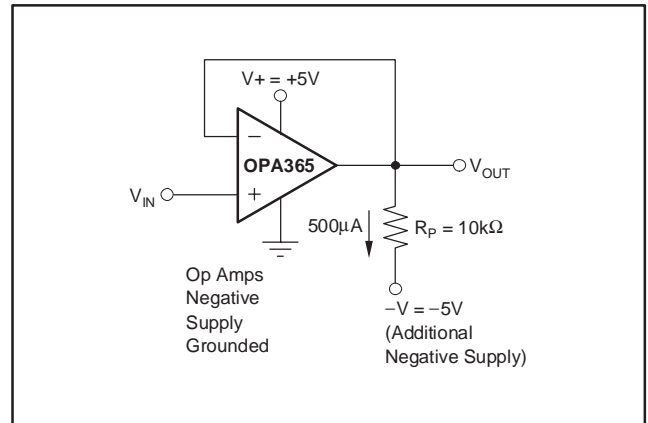

**Figure 7. Swing-to-Ground**

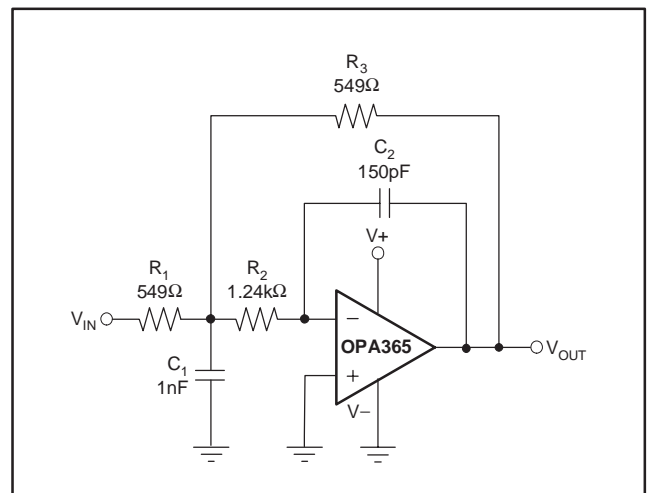

**Figure 8. Second-Order Butterworth 500kHz Low-Pass Filter**

### ACTIVE FILTERING

The OPA365 is well-suited for active filter applications requiring a wide bandwidth, fast slew rate, low-noise, single-supply operational amplifier. Figure 8 shows a 500kHz, 2nd-order, low-pass filter utilizing the multiple-feedback (MFB) topology. The components have been selected to provide a maximally-flat Butterworth response. Beyond the cutoff frequency, roll-off is -40dB/dec. The Butterworth response is ideal for applications requiring predictable gain characteristics such as the anti-aliasing filter used ahead of an ADC.

One point to observe when considering the MFB filter is that the output is inverted, relative to the input. If this inversion is not required, or not desired, a noninverting output can be achieved through one of these options: 1) adding an inverting amplifier; 2) adding an additional 2nd-order MFB stage; or 3) using a noninverting filter topology such as the Sallen-Key (shown in Figure 9).

MFB and Sallen-Key, low-pass and high-pass filter synthesis is quickly accomplished using TI's FilterPro program. This software is available as a free download at [www.ti.com](http://www.ti.com).

### DRIVING AN ANALOG-TO-DIGITAL CONVERTER

Very wide common-mode input range, rail-to-rail input and output voltage capability and high speed make the

OPA365 an ideal driver for modern ADCs. Also, because it is free of the input offset transition characteristics inherent to some rail-to-rail CMOS op amps, the OPA365 provides low THD and excellent linearity throughout the input voltage swing range.

Figure 10 shows the OPA365 driving an ADS8326, 16-bit, 250kSPS converter. The amplifier is connected as a unity-gain, noninverting buffer and has an output swing to 0V, making it directly compatible with the ADC minus full-scale input level. The 0V level is achieved by powering the OPA365 V- pin with a small negative voltage established by the diode forward voltage drop. A small, signal-switching diode or Schottky diode provides a suitable negative supply voltage of -0.3 to -0.7V. The supply rail-to-rail is equal to V+, plus the small negative voltage.

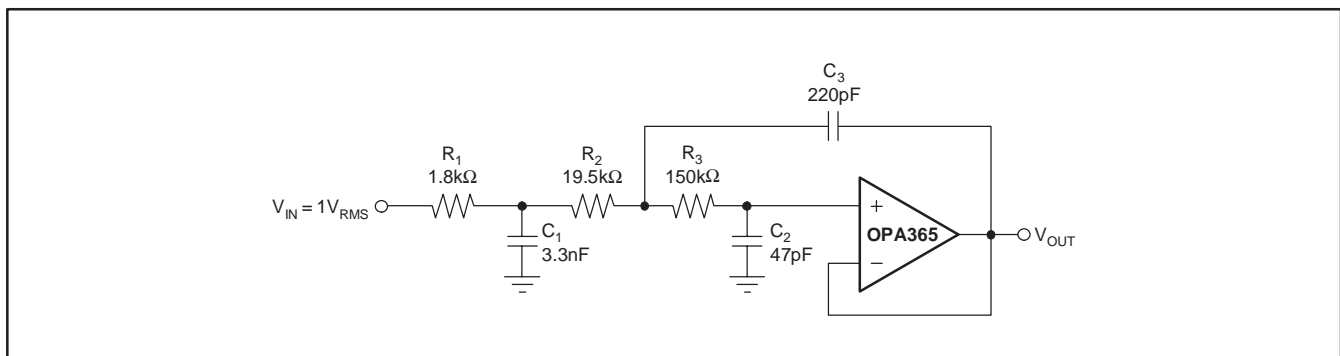

Figure 9. Configured as a 3-Pole, 20kHz, Sallen-Key Filter

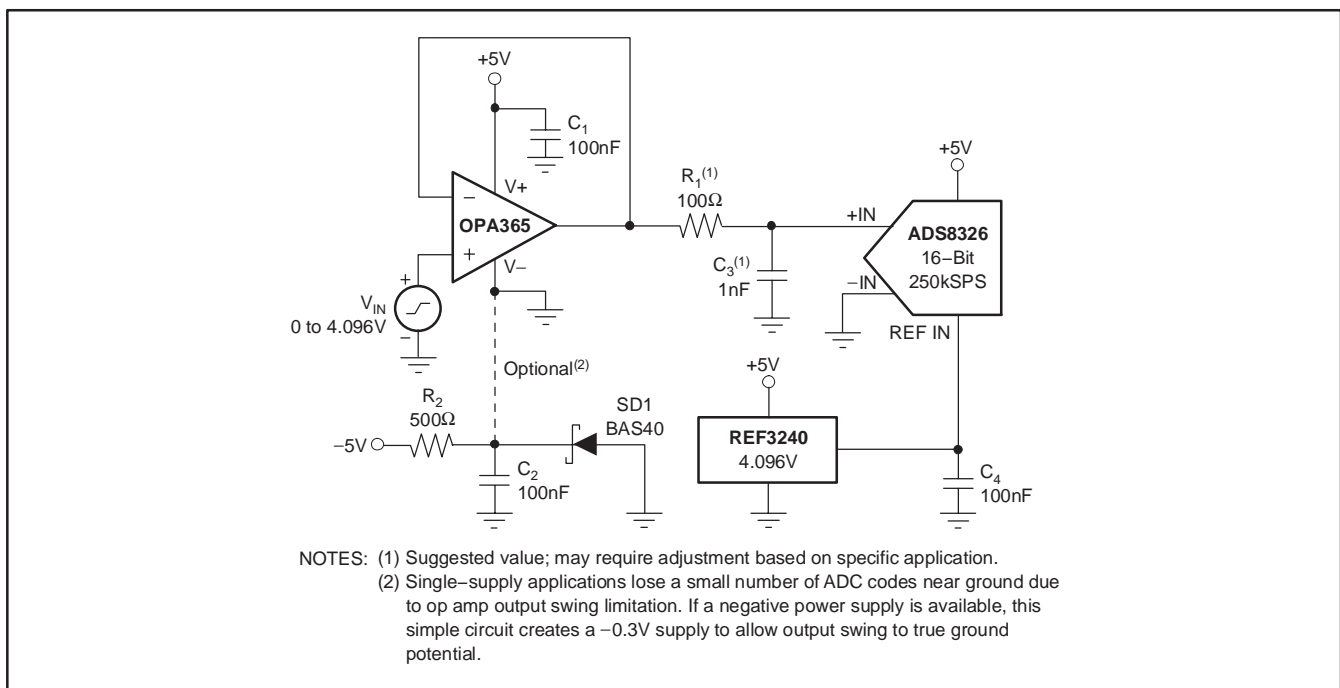

Figure 10. Driving the ADS8326

One method for driving an ADC that negates the need for an output swing down to 0V uses a slightly compressed ADC full-scale input range (FSR). For example, the 16-bit ADS8361 (shown in Figure 11) has a maximum FSR of 0V to 5V, when powered by a +5V supply and  $V_{REF}$  of 2.5V. The idea is to match the ADC input range with the op amp full linear output swing range; for example, an output range of +0.1 to +4.9V. The reference output from the ADS8361 ADC is divided down from 2.5V to 2.4V using a resistive divider. The ADC FSR then becomes  $4.8V_{PP}$  centered on a common-mode voltage of +2.5V. Current from the ADS8361 reference pin is limited to about  $\pm 10\mu A$ . Here,  $5\mu A$  was used to bias the divider. The resistors must be precise

to maintain the ADC gain accuracy. An additional benefit of this method is the elimination of the negative supply voltage; it requires no additional power-supply current.

An RC network, consisting of  $R_1$  and  $C_1$ , is included between the op amp and the ADS8361. It not only provides a high-frequency filter function, but more importantly serves as a charge reservoir used for charging the converter internal hold capacitance. This capability assures that the op amp output linearity is maintained as the ADC input characteristics change throughout the conversion cycle. Depending on the particular application and ADC, some optimization of the  $R_1$  and  $C_1$  values may be required for best transient performance.

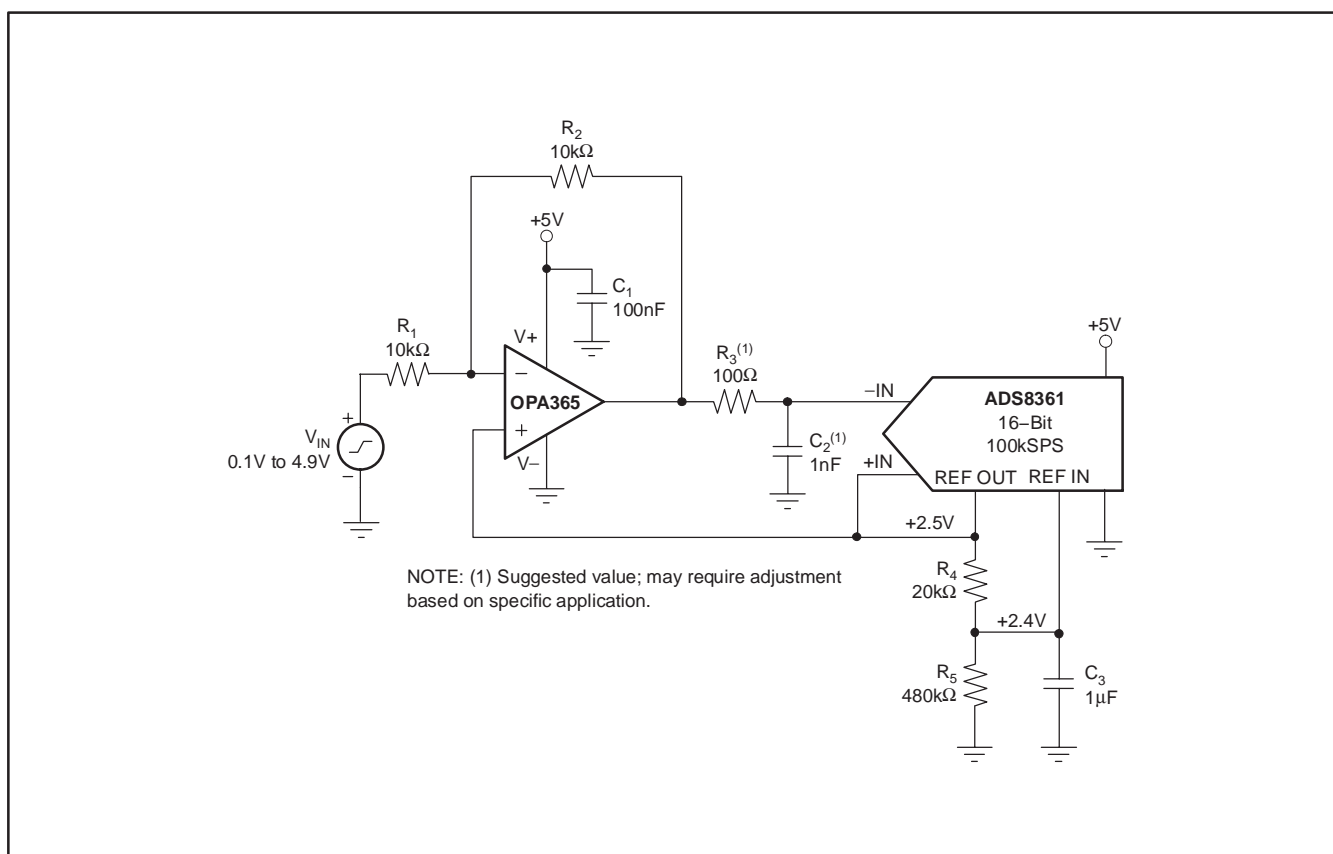

Figure 11. Driving the ADS8361

Figure 12 illustrates the OPA2365 dual op amp providing signal conditioning within an ADS1258 bridge sensor circuit. It follows the ADS1258 16:1 multiplexer and is connected as a differential in/differential out amplifier. The voltage gain for this stage is approximately 10V/V. Driving the ADS1258 internal ADC in differential mode, rather than in a single-ended, exploits the full linearity performance capability of the converter. For best common-mode rejection the two  $R_2$  resistors should be closely matched.

Note that in Figure 12, the amplifiers, bridges, ADS1258 and internal reference are powered by the same single +5V supply. This ratiometric connection helps cancel excitation voltage drift effects and noise.

For best performance, the +5V supply should be as free as possible of noise and transients.

When the ADS1258 data rate is set to maximum and the chop feature enabled, this circuit yields 12 bits of noise-free resolution with a 50mV full-scale input.

The chop feature is used to reduce the ADS1258 offset and offset drift to very low levels. A 2.2nF capacitor is required across the ADC inputs to bypass the sampling currents. The 47Ω resistors provide isolation for the OPA2365 outputs from the relatively large, 2.2nF capacitive load. For more information regarding the ADS1258, see the product data sheet available for download at [www.ti.com](http://www.ti.com).

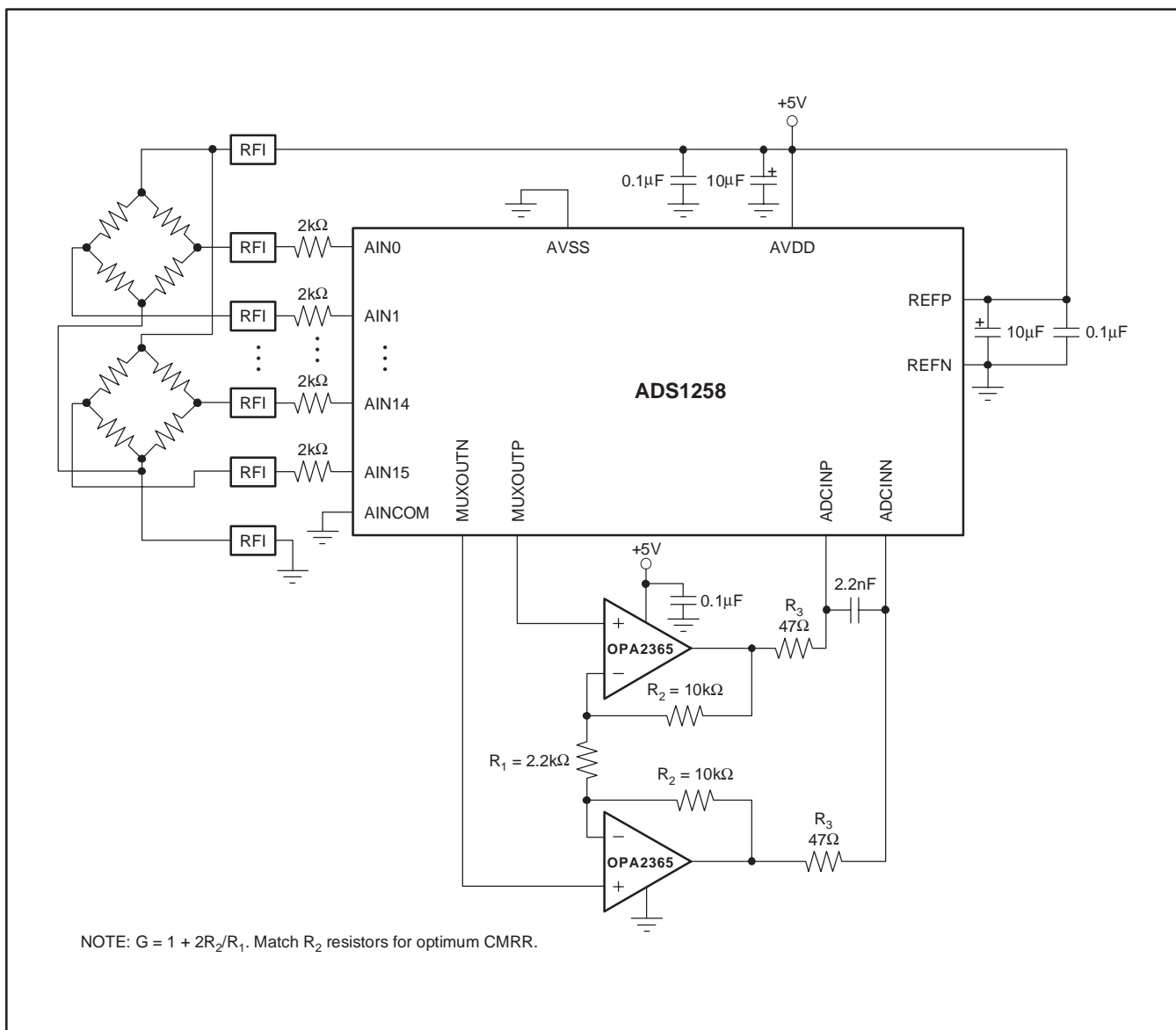

Figure 12. Conditioning Input Signals to the ADS1258 on a Single-Supply

---

## Revision History

DATE	REV	PAGE	SECTION	DESCRIPTION
6/09	D	1	Front Page	Changed title.
				Changed feature bullets.
				Changed drawing.
				Deleted table.

NOTE: Page numbers for previous revisions may differ from page numbers in the current version.

**PACKAGING INFORMATION**

Orderable Device	Status (1)	Package Type	Package Drawing	Pins	Package Qty	Eco Plan (2)	Lead/Ball Finish (6)	MSL Peak Temp (3)	Op Temp (°C)	Device Marking (4/5)	Samples
OPA2365AID	ACTIVE	SOIC	D	8	75	Green (RoHS & no Sb/Br)	CU NIPDAU	Level-1-260C-UNLIM	-40 to 125	O2365A	<a href="#">Samples</a>
OPA2365AIDG4	ACTIVE	SOIC	D	8	75	Green (RoHS & no Sb/Br)	CU NIPDAU	Level-1-260C-UNLIM	-40 to 125	O2365A	<a href="#">Samples</a>
OPA2365AIDR	ACTIVE	SOIC	D	8	2500	Green (RoHS & no Sb/Br)	CU NIPDAU	Level-1-260C-UNLIM	-40 to 125	O2365A	<a href="#">Samples</a>
OPA2365AIDRG4	ACTIVE	SOIC	D	8	2500	Green (RoHS & no Sb/Br)	CU NIPDAU	Level-1-260C-UNLIM	-40 to 125	O2365A	<a href="#">Samples</a>
OPA365AID	ACTIVE	SOIC	D	8	75	Green (RoHS & no Sb/Br)	CU NIPDAU	Level-1-260C-UNLIM	-40 to 125	O365A	<a href="#">Samples</a>
OPA365AIDBVR	ACTIVE	SOT-23	DBV	5	3000	Green (RoHS & no Sb/Br)	CU NIPDAU	Level-1-260C-UNLIM	-40 to 125	OAVQ	<a href="#">Samples</a>
OPA365AIDBVRG4	ACTIVE	SOT-23	DBV	5	3000	Green (RoHS & no Sb/Br)	CU NIPDAU	Level-1-260C-UNLIM	-40 to 125	OAVQ	<a href="#">Samples</a>
OPA365AIDBVT	ACTIVE	SOT-23	DBV	5	250	Green (RoHS & no Sb/Br)	CU NIPDAU	Level-1-260C-UNLIM	-40 to 125	OAVQ	<a href="#">Samples</a>
OPA365AIDBVTG4	ACTIVE	SOT-23	DBV	5	250	Green (RoHS & no Sb/Br)	CU NIPDAU	Level-1-260C-UNLIM	-40 to 125	OAVQ	<a href="#">Samples</a>
OPA365AIDG4	ACTIVE	SOIC	D	8	75	Green (RoHS & no Sb/Br)	CU NIPDAU	Level-1-260C-UNLIM	-40 to 125	O365A	<a href="#">Samples</a>
OPA365AIDR	ACTIVE	SOIC	D	8	2500	Green (RoHS & no Sb/Br)	CU NIPDAU	Level-1-260C-UNLIM	-40 to 125	O365A	<a href="#">Samples</a>
OPA365AIDRG4	ACTIVE	SOIC	D	8	2500	Green (RoHS & no Sb/Br)	CU NIPDAU	Level-1-260C-UNLIM	-40 to 125	O365A	<a href="#">Samples</a>

(1) The marketing status values are defined as follows:

**ACTIVE:** Product device recommended for new designs.

**LIFEBUY:** TI has announced that the device will be discontinued, and a lifetime-buy period is in effect.

**NRND:** Not recommended for new designs. Device is in production to support existing customers, but TI does not recommend using this part in a new design.

**PREVIEW:** Device has been announced but is not in production. Samples may or may not be available.

**OBSELETE:** TI has discontinued the production of the device.

(2) Eco Plan - The planned eco-friendly classification: Pb-Free (RoHS), Pb-Free (RoHS Exempt), or Green (RoHS & no Sb/Br) - please check <http://www.ti.com/productcontent> for the latest availability information and additional product content details.

**TBD:** The Pb-Free/Green conversion plan has not been defined.

**Pb-Free (RoHS):** TI's terms "Lead-Free" or "Pb-Free" mean semiconductor products that are compatible with the current RoHS requirements for all 6 substances, including the requirement that lead not exceed 0.1% by weight in homogeneous materials. Where designed to be soldered at high temperatures, TI Pb-Free products are suitable for use in specified lead-free processes.

**Pb-Free (RoHS Exempt):** This component has a RoHS exemption for either 1) lead-based flip-chip solder bumps used between the die and package, or 2) lead-based die adhesive used between the die and leadframe. The component is otherwise considered Pb-Free (RoHS compatible) as defined above.

**Green (RoHS & no Sb/Br):** TI defines "Green" to mean Pb-Free (RoHS compatible), and free of Bromine (Br) and Antimony (Sb) based flame retardants (Br or Sb do not exceed 0.1% by weight in homogeneous material)

<sup>(3)</sup> MSL, Peak Temp. - The Moisture Sensitivity Level rating according to the JEDEC industry standard classifications, and peak solder temperature.

<sup>(4)</sup> There may be additional marking, which relates to the logo, the lot trace code information, or the environmental category on the device.

<sup>(5)</sup> Multiple Device Markings will be inside parentheses. Only one Device Marking contained in parentheses and separated by a "~" will appear on a device. If a line is indented then it is a continuation of the previous line and the two combined represent the entire Device Marking for that device.

<sup>(6)</sup> Lead/Ball Finish - Orderable Devices may have multiple material finish options. Finish options are separated by a vertical ruled line. Lead/Ball Finish values may wrap to two lines if the finish value exceeds the maximum column width.

**Important Information and Disclaimer:** The information provided on this page represents TI's knowledge and belief as of the date that it is provided. TI bases its knowledge and belief on information provided by third parties, and makes no representation or warranty as to the accuracy of such information. Efforts are underway to better integrate information from third parties. TI has taken and continues to take reasonable steps to provide representative and accurate information but may not have conducted destructive testing or chemical analysis on incoming materials and chemicals. TI and TI suppliers consider certain information to be proprietary, and thus CAS numbers and other limited information may not be available for release.

In no event shall TI's liability arising out of such information exceed the total purchase price of the TI part(s) at issue in this document sold by TI to Customer on an annual basis.

**OTHER QUALIFIED VERSIONS OF OPA2365, OPA365 :**

● Automotive: [OPA2365-Q1](#), [OPA365-Q1](#)

● Enhanced Product: [OPA365-EP](#)

NOTE: Qualified Version Definitions:

- Automotive - Q100 devices qualified for high-reliability automotive applications targeting zero defects
- Enhanced Product - Supports Defense, Aerospace and Medical Applications

**TAPE AND REEL INFORMATION**

**QUADRANT ASSIGNMENTS FOR PIN 1 ORIENTATION IN TAPE**

\*All dimensions are nominal

Device	Package Type	Package Drawing	Pins	SPQ	Reel Diameter (mm)	Reel Width W1 (mm)	A0 (mm)	B0 (mm)	K0 (mm)	P1 (mm)	W (mm)	Pin1 Quadrant
OPA2365AIDR	SOIC	D	8	2500	330.0	12.4	6.4	5.2	2.1	8.0	12.0	Q1
OPA365AIDBVR	SOT-23	DBV	5	3000	178.0	9.0	3.3	3.2	1.4	4.0	8.0	Q3
OPA365AIDBVT	SOT-23	DBV	5	250	178.0	9.0	3.3	3.2	1.4	4.0	8.0	Q3
OPA365AIDR	SOIC	D	8	2500	330.0	12.4	6.4	5.2	2.1	8.0	12.0	Q1

**TAPE AND REEL BOX DIMENSIONS**

\*All dimensions are nominal

Device	Package Type	Package Drawing	Pins	SPQ	Length (mm)	Width (mm)	Height (mm)
OPA2365AIDR	SOIC	D	8	2500	367.0	367.0	35.0
OPA365AIDBVR	SOT-23	DBV	5	3000	180.0	180.0	18.0
OPA365AIDBVT	SOT-23	DBV	5	250	180.0	180.0	18.0
OPA365AIDR	SOIC	D	8	2500	367.0	367.0	35.0

DBV (R-PDSO-G5)

PLASTIC SMALL-OUTLINE PACKAGE

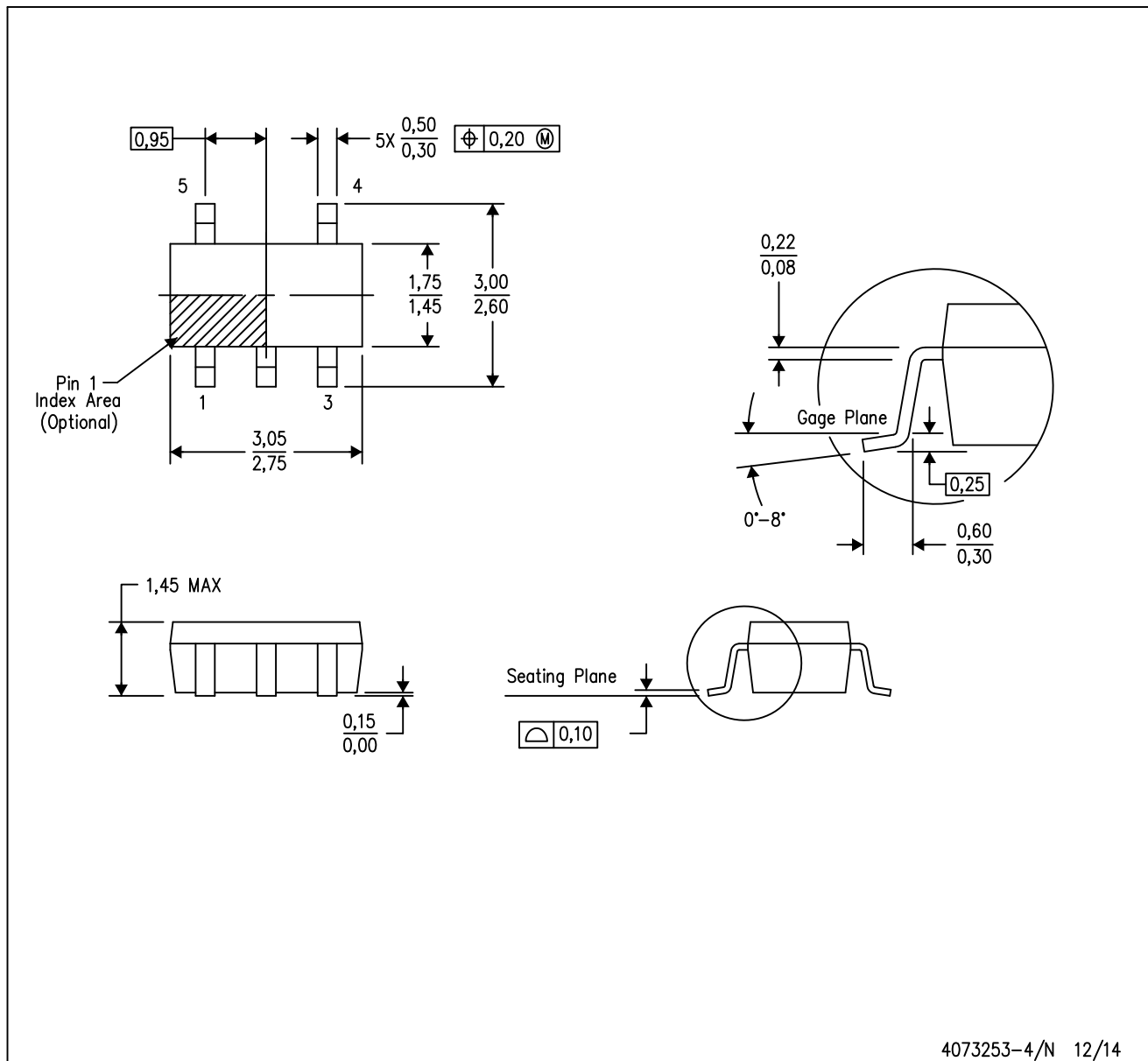

- NOTES:
- A. All linear dimensions are in millimeters.
  - B. This drawing is subject to change without notice.
  - C. Body dimensions do not include mold flash or protrusion. Mold flash and protrusion shall not exceed 0.15 per side.
  - D. Falls within JEDEC MO-178 Variation AA.

DBV (R-PDSO-G5)

PLASTIC SMALL OUTLINE



- NOTES:
- A. All linear dimensions are in millimeters.
  - B. This drawing is subject to change without notice.
  - C. Customers should place a note on the circuit board fabrication drawing not to alter the center solder mask defined pad.
  - D. Publication IPC-7351 is recommended for alternate designs.
  - E. Laser cutting apertures with trapezoidal walls and also rounding corners will offer better paste release. Customers should contact their board assembly site for stencil design recommendations. Example stencil design based on a 50% volumetric metal load solder paste. Refer to IPC-7525 for other stencil recommendations.

D (R-PDSO-G8)

PLASTIC SMALL OUTLINE

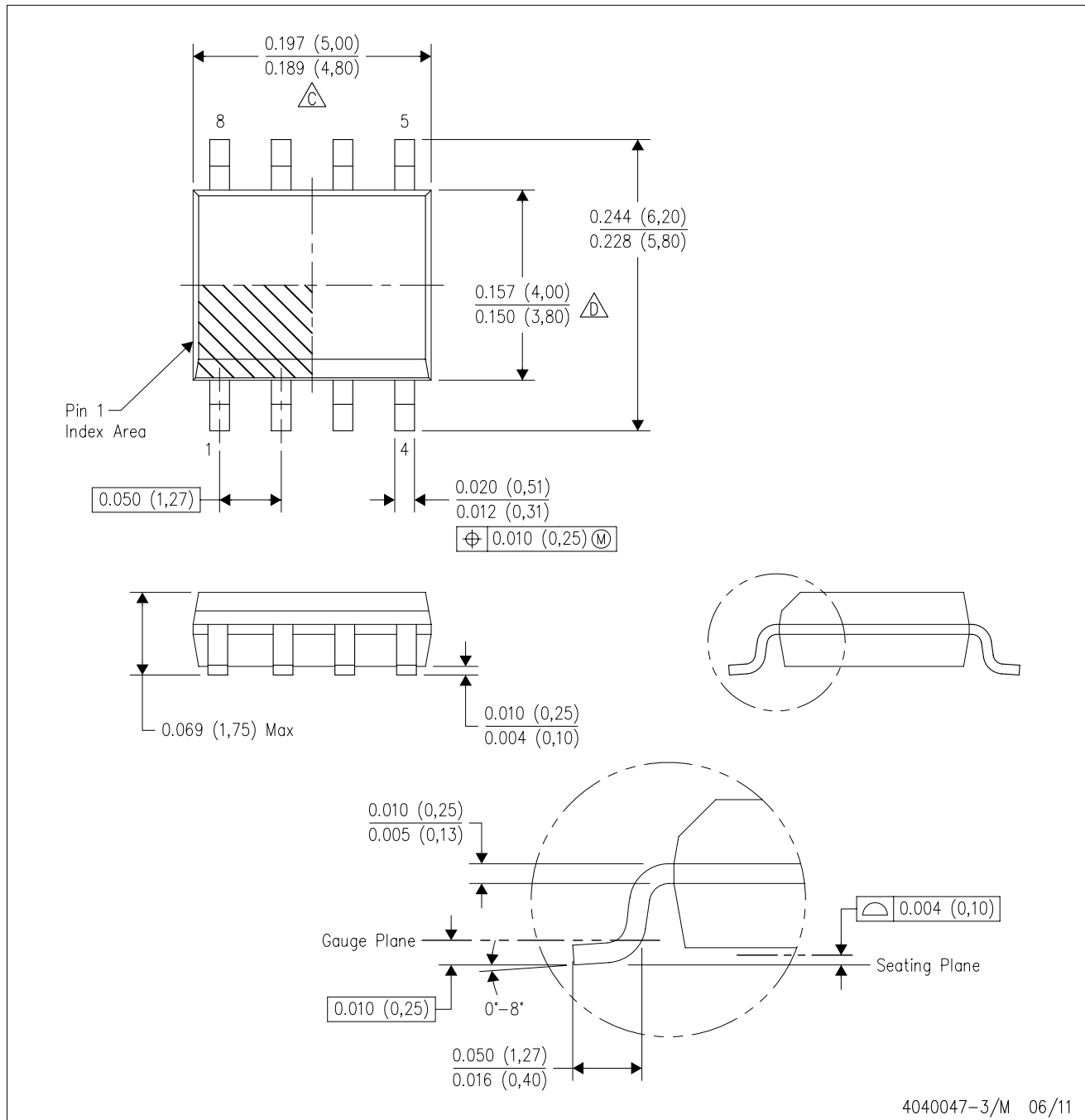

- NOTES:
- A. All linear dimensions are in inches (millimeters).
  - B. This drawing is subject to change without notice.
  - C. Body length does not include mold flash, protrusions, or gate burrs. Mold flash, protrusions, or gate burrs shall not exceed 0.006 (0,15) each side.
  - D. Body width does not include interlead flash. Interlead flash shall not exceed 0.017 (0,43) each side.
  - E. Reference JEDEC MS-012 variation AA.

D (R-PDSO-G8)

PLASTIC SMALL OUTLINE



- NOTES:
- A. All linear dimensions are in millimeters.
  - B. This drawing is subject to change without notice.
  - C. Publication IPC-7351 is recommended for alternate designs.
  - D. Laser cutting apertures with trapezoidal walls and also rounding corners will offer better paste release. Customers should contact their board assembly site for stencil design recommendations. Refer to IPC-7525 for other stencil recommendations.
  - E. Customers should contact their board fabrication site for solder mask tolerances between and around signal pads.

## IMPORTANT NOTICE

Texas Instruments Incorporated and its subsidiaries (TI) reserve the right to make corrections, enhancements, improvements and other changes to its semiconductor products and services per JESD46, latest issue, and to discontinue any product or service per JESD48, latest issue. Buyers should obtain the latest relevant information before placing orders and should verify that such information is current and complete. All semiconductor products (also referred to herein as "components") are sold subject to TI's terms and conditions of sale supplied at the time of order acknowledgment.

TI warrants performance of its components to the specifications applicable at the time of sale, in accordance with the warranty in TI's terms and conditions of sale of semiconductor products. Testing and other quality control techniques are used to the extent TI deems necessary to support this warranty. Except where mandated by applicable law, testing of all parameters of each component is not necessarily performed.

TI assumes no liability for applications assistance or the design of Buyers' products. Buyers are responsible for their products and applications using TI components. To minimize the risks associated with Buyers' products and applications, Buyers should provide adequate design and operating safeguards.

TI does not warrant or represent that any license, either express or implied, is granted under any patent right, copyright, mask work right, or other intellectual property right relating to any combination, machine, or process in which TI components or services are used. Information published by TI regarding third-party products or services does not constitute a license to use such products or services or a warranty or endorsement thereof. Use of such information may require a license from a third party under the patents or other intellectual property of the third party, or a license from TI under the patents or other intellectual property of TI.

Reproduction of significant portions of TI information in TI data books or data sheets is permissible only if reproduction is without alteration and is accompanied by all associated warranties, conditions, limitations, and notices. TI is not responsible or liable for such altered documentation. Information of third parties may be subject to additional restrictions.

Resale of TI components or services with statements different from or beyond the parameters stated by TI for that component or service voids all express and any implied warranties for the associated TI component or service and is an unfair and deceptive business practice. TI is not responsible or liable for any such statements.

Buyer acknowledges and agrees that it is solely responsible for compliance with all legal, regulatory and safety-related requirements concerning its products, and any use of TI components in its applications, notwithstanding any applications-related information or support that may be provided by TI. Buyer represents and agrees that it has all the necessary expertise to create and implement safeguards which anticipate dangerous consequences of failures, monitor failures and their consequences, lessen the likelihood of failures that might cause harm and take appropriate remedial actions. Buyer will fully indemnify TI and its representatives against any damages arising out of the use of any TI components in safety-critical applications.

In some cases, TI components may be promoted specifically to facilitate safety-related applications. With such components, TI's goal is to help enable customers to design and create their own end-product solutions that meet applicable functional safety standards and requirements. Nonetheless, such components are subject to these terms.

No TI components are authorized for use in FDA Class III (or similar life-critical medical equipment) unless authorized officers of the parties have executed a special agreement specifically governing such use.

Only those TI components which TI has specifically designated as military grade or "enhanced plastic" are designed and intended for use in military/aerospace applications or environments. Buyer acknowledges and agrees that any military or aerospace use of TI components which have **not** been so designated is solely at the Buyer's risk, and that Buyer is solely responsible for compliance with all legal and regulatory requirements in connection with such use.

TI has specifically designated certain components as meeting ISO/TS16949 requirements, mainly for automotive use. In any case of use of non-designated products, TI will not be responsible for any failure to meet ISO/TS16949.

### Products

Audio	<a href="http://www.ti.com/audio">www.ti.com/audio</a>
Amplifiers	<a href="http://amplifier.ti.com">amplifier.ti.com</a>
Data Converters	<a href="http://dataconverter.ti.com">dataconverter.ti.com</a>
DLP® Products	<a href="http://www.dlp.com">www.dlp.com</a>
DSP	<a href="http://dsp.ti.com">dsp.ti.com</a>
Clocks and Timers	<a href="http://www.ti.com/clocks">www.ti.com/clocks</a>
Interface	<a href="http://interface.ti.com">interface.ti.com</a>
Logic	<a href="http://logic.ti.com">logic.ti.com</a>
Power Mgmt	<a href="http://power.ti.com">power.ti.com</a>
Microcontrollers	<a href="http://microcontroller.ti.com">microcontroller.ti.com</a>
RFID	<a href="http://www.ti-rfid.com">www.ti-rfid.com</a>
OMAP Applications Processors	<a href="http://www.ti.com/omap">www.ti.com/omap</a>
Wireless Connectivity	<a href="http://www.ti.com/wirelessconnectivity">www.ti.com/wirelessconnectivity</a>

### Applications

Automotive and Transportation	<a href="http://www.ti.com/automotive">www.ti.com/automotive</a>
Communications and Telecom	<a href="http://www.ti.com/communications">www.ti.com/communications</a>
Computers and Peripherals	<a href="http://www.ti.com/computers">www.ti.com/computers</a>
Consumer Electronics	<a href="http://www.ti.com/consumer-apps">www.ti.com/consumer-apps</a>
Energy and Lighting	<a href="http://www.ti.com/energy">www.ti.com/energy</a>
Industrial	<a href="http://www.ti.com/industrial">www.ti.com/industrial</a>
Medical	<a href="http://www.ti.com/medical">www.ti.com/medical</a>
Security	<a href="http://www.ti.com/security">www.ti.com/security</a>
Space, Avionics and Defense	<a href="http://www.ti.com/space-avionics-defense">www.ti.com/space-avionics-defense</a>
Video and Imaging	<a href="http://www.ti.com/video">www.ti.com/video</a>

### TI E2E Community

[e2e.ti.com](http://e2e.ti.com)