

OPT101 Monolithic Photodiode and Single-Supply Transimpedance Amplifier

1 Features

- Single Supply: 2.7 to 36 V
- Photodiode Size: 0.090 inch × 0.090 inch (2.29 mm × 2.29 mm)
- Internal 1-M Ω Feedback Resistor
- High Responsivity: 0.45 A/W (650 nm)
- Bandwidth: 14 kHz at $R_F = 1\text{ M}\Omega$
- Low Quiescent Current: 120 μA
- Packages: Clear Plastic 8-pin PDIP and J-Lead SOP

2 Applications

- Medical Instrumentation
- Laboratory Instrumentation
- Position and Proximity Sensors
- Photographic Analyzers
- Barcode Scanners
- Smoke Detectors
- Currency Changers

3 Description

The OPT101 is a monolithic photodiode with on-chip transimpedance amplifier. The integrated combination of photodiode and transimpedance amplifier on a single chip eliminates the problems commonly encountered in discrete designs, such as leakage current errors, noise pick-up, and gain peaking as a result of stray capacitance. Output voltage increases linearly with light intensity. The amplifier is designed for single or dual power-supply operation.

The 0.09 inch × 0.09 inch (2.29 mm × 2.29 mm) photodiode operates in the photoconductive mode for excellent linearity and low dark current.

The OPT101 operates from 2.7 V to 36 V supplies and quiescent current is only 120 μA . This device is available in clear plastic 8-pin PDIP, and J-lead SOP for surface mounting. The temperature range is 0°C to 70°C.

Device Information⁽¹⁾

PART NUMBER	PACKAGE	BODY SIZE (NOM)
OPT101	PDIP (8)	9.53 mm × 6.52 mm
	SOP (8)	9.52 mm × 6.52 mm

(1) For all available packages, see the package option addendum at the end of the data sheet.

Block Diagram

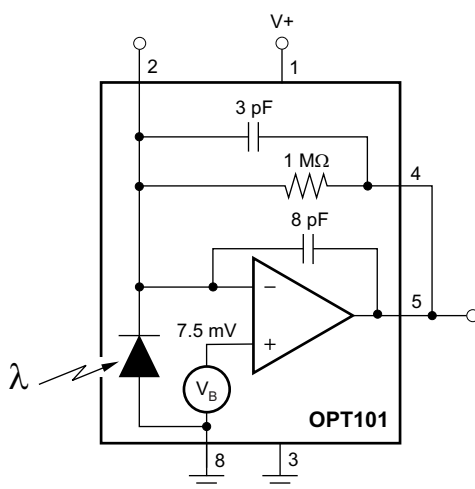

Spectral Responsivity

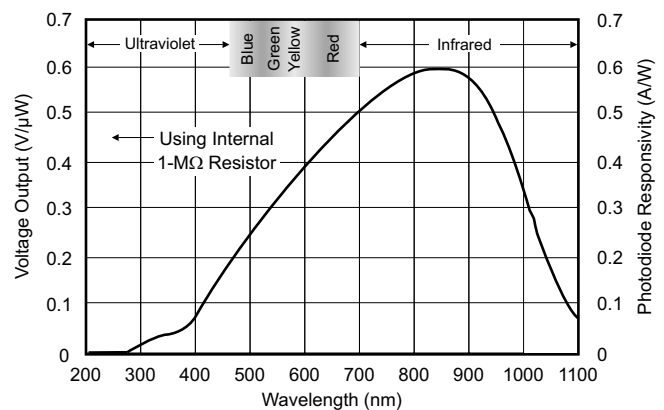

5 Pin Configuration and Functions

**DTL and NTC Packages
8-pin SOP and 8-pin PDIP
Top View**

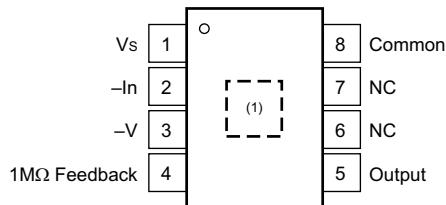

(1) Photodiode location.

Pin Functions

PIN		I/O	DESCRIPTION
NO.	NAME		
1	V _S	Power	Power supply of device. Apply 2.7 V to 36 V relative to –V pin.
2	–In	Input	Negative input of op amp and the cathode of the photodiode. Either do not connect, or apply additional op amp feedback.
3	–V	Power	Most negative power supply. Connect to ground or a negative voltage that meets the recommended operating conditions.
4	1MΩ Feedback	Input	Connection to internal feedback network. Typically connect to Output, pin 5.
5	Output	Output	Output of device.
6	NC	—	Do not connect
7	NC	—	Do not connect
8	Common	Input	Anode of the photodiode. Typically, connect to ground.

6 Specifications

6.1 Absolute Maximum Ratings

over operating free-air temperature range (unless otherwise noted) ⁽¹⁾

		MIN	MAX	UNIT
Supply voltage (V_S to Common pin or $-V$ pin)		0	36	V
Output short-circuit (to ground)		Continuous		
Temperature	Operating	-25	85	°C
	Junction		85	°C
	Storage, T_{stg}	-25	85	°C

(1) Stresses beyond those listed under *Absolute Maximum Ratings* may cause permanent damage to the device. These are stress ratings only, which do not imply functional operation of the device at these or any other conditions beyond those indicated under *Recommended Operating Conditions*. Exposure to absolute-maximum-rated conditions for extended periods may affect device reliability.

6.2 ESD Ratings

		VALUE	UNIT
$V_{(ESD)}$ Electrostatic discharge	Human-body model (HBM), per ANSI/ESDA/JEDEC JS-001 ⁽¹⁾	±2000	V
	Charged-device model (CDM), per JEDEC specification JESD22-C101 ⁽²⁾	±500	

(1) JEDEC document JEP155 states that 500-V HBM allows safe manufacturing with a standard ESD control process.

(2) JEDEC document JEP157 states that 250-V CDM allows safe manufacturing with a standard ESD control process.

6.3 Recommended Operating Conditions

over operating free-air temperature range (unless otherwise noted)

		MIN	NOM	MAX	UNIT
POWER SUPPLY					
Operating voltage		2.7		36	V
TEMPERATURE					
Specified		0		70	°C
Operating		0		70	°C

6.4 Thermal Information

THERMAL METRIC ⁽¹⁾		OPT101		UNIT
		DTL (SOP)	NTC (PDIP)	
		8 PINS	8 PINS	
$R_{\theta JA}$	Junction-to-ambient thermal resistance	138.6	128.2	°C/W
$R_{\theta JC(top)}$	Junction-to-case (top) thermal resistance	96.4	113.1	°C/W
$R_{\theta JB}$	Junction-to-board thermal resistance	126.6	107.0	°C/W
ψ_{JT}	Junction-to-top characterization parameter	17.8	24.2	°C/W
ψ_{JB}	Junction-to-board characterization parameter	118.8	105.9	°C/W

(1) For more information about traditional and new thermal metrics, see the *Semiconductor and IC Package Thermal Metrics* application report, [SPRA953](#).

6.5 Electrical Characteristics

At $T_A = 25^\circ\text{C}$, $V_S = 2.7\text{ V to }36\text{ V}$, $\lambda = 650\text{ nm}$, internal 1-M Ω feedback resistor, and $R_L = 10\text{ k}\Omega$ (unless otherwise noted)

PARAMETER	TEST CONDITIONS	MIN	TYP	MAX	UNIT
RESPONSIVITY					
Photodiode current			0.45		A/W
Voltage output			0.45		V/ μW
Voltage output vs temperature			100		ppm/ $^\circ\text{C}$
Unit-to-unit variation			$\pm 5\%$		
Nonlinearity ⁽¹⁾	Full-scale (FS) output = 24 V		± 0.01		% of FS
Photodiode area	0.090 in \times 0.090 in		0.008		in ²
	2.29 mm \times 2.29 mm		5.2		mm ²
DARK ERRORS, RTO⁽²⁾					
Offset voltage, output		5	7.5	10	mV
Offset voltage vs temperature			± 10		$\mu\text{V}/^\circ\text{C}$
Offset voltage vs power supply	$V_S = 2.7\text{ V to }36\text{ V}$		10	100	$\mu\text{V}/\text{V}$
Voltage noise, dark	$f_B = 0.1\text{ Hz to }20\text{ kHz}$, $V_S = 15\text{ V}$, $V_{PIN3} = -15\text{ V}$		300		μVrms
TRANSIMPEDANCE GAIN					
Resistor			1		M Ω
Tolerance			$\pm 0.5\%$	$\pm 2\%$	
Tolerance vs temperature			± 50		ppm/ $^\circ\text{C}$
FREQUENCY RESPONSE					
Bandwidth	$V_{OUT} = 10\text{ V}_{PP}$		14		kHz
Rise and fall time	10% to 90%, $V_{OUT} = 10\text{-V step}$		28		μs
Settling time	to 0.05%, $V_{OUT} = 10\text{-V step}$		160		μs
	to 0.1%, $V_{OUT} = 10\text{-V step}$		80		μs
	to 1%, $V_{OUT} = 10\text{-V step}$		70		μs
Overload recovery	100%, return to linear operation		50		μs
OUTPUT					
Voltage output, high		$(V_S) - 1.3$	$(V_S) - 1.15$		V
Capacitive load, stable operation			10		nF
Short-circuit current	$V_S = 36\text{ V}$		15		mA
POWER SUPPLY					
Quiescent current	Dark, $V_{PIN3} = 0\text{ V}$		120		μA
	$R_L = \infty$, $V_{OUT} = 10\text{ V}$		220		μA

(1) Deviation in percent of full scale from best-fit straight line.

(2) Referred to output. Includes all error sources.

6.6 Electrical Characteristics: Photodiode

 At $T_A = 25^\circ\text{C}$ and $V_S = 2.7\text{ V}$ to 36 V (unless otherwise noted)

PARAMETER	TEST CONDITIONS	MIN	TYP	MAX	UNIT
Photodiode area	0.090 in × 0.090 in		0.008		in ²
	2.29 mm × 2.29 mm		5.2		mm ²
Current responsivity	$\lambda = 650\text{ nm}$		0.45		A/W
			865		($\mu\text{A/W}$)/cm ²
Dark current	$V_{\text{DIODE}} = 7.5\text{ mV}$		2.5		pA
Dark current vs temperature	$V_{\text{DIODE}} = 7.5\text{ mV}$		Doubles every 7°C		—
Capacitance			1200		pF

6.7 Electrical Characteristics: Op Amp⁽¹⁾

 At $T_A = 25^\circ\text{C}$, $V_S = 2.7\text{ V}$ to 36 V , $\lambda = 650\text{ nm}$, internal 1-M Ω feedback resistor, and $R_L = 10\text{ k}\Omega$ (unless otherwise noted)

PARAMETER	TEST CONDITIONS	MIN	TYP	MAX	UNIT
INPUT					
Offset voltage			±0.5		mV
vs temperature			±2.5		$\mu\text{V}/^\circ\text{C}$
vs power supply			10		$\mu\text{V/V}$
Input bias current	(–) input		165		pA
vs temperature	(–) input		Doubles every 10°C		—
Input impedance	Differential		400 5		M Ω pF
	Common-mode		250 35		G Ω pF
Common-mode input voltage range	Linear operation		0 to ($V_S - 1$)		V
Common-mode rejection			90		dB
OPEN-LOOP GAIN					
Open-loop voltage gain			90		dB
FREQUENCY RESPONSE					
Gain bandwidth product ⁽²⁾			2		MHz
Slew rate			1		V/ μs
Settling time	0.05%		8.0		μs
	0.1%		7.7		μs
	1%		5.8		μs
OUTPUT					
Voltage output, high		$(V_S) - 1.3$ $(V_S) - 1.15$			V
Short-circuit current	$V_S = 36\text{ V}$		15		mA
POWER SUPPLY					
Quiescent current	Dark, $V_{\text{PIN3}} = 0\text{ V}$		120		μA
	$R_L = \infty$, $V_{\text{OUT}} = 10\text{ V}$		220		μA

(1) Op amp specifications provided for information and comparison only.

 (2) Stable gains $\geq 10\text{ V/V}$.

6.8 Typical Characteristics

At $T_A = 25^\circ\text{C}$, $V_S = 2.7\text{ V to }36\text{ V}$, $\lambda = 650\text{ nm}$, internal $1\text{-M}\Omega$ feedback resistor, and $R_L = 10\text{ k}\Omega$ (unless otherwise noted)

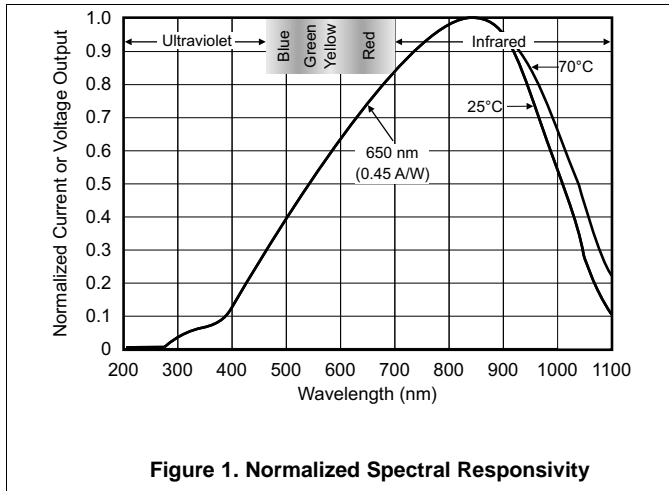

Figure 1. Normalized Spectral Responsivity

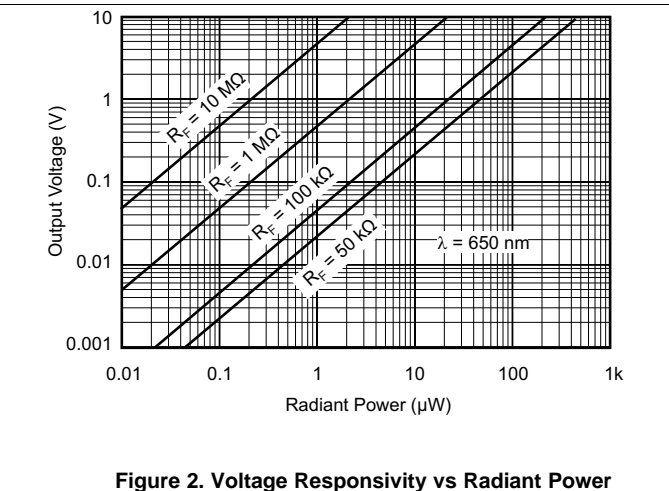

Figure 2. Voltage Responsivity vs Radiant Power

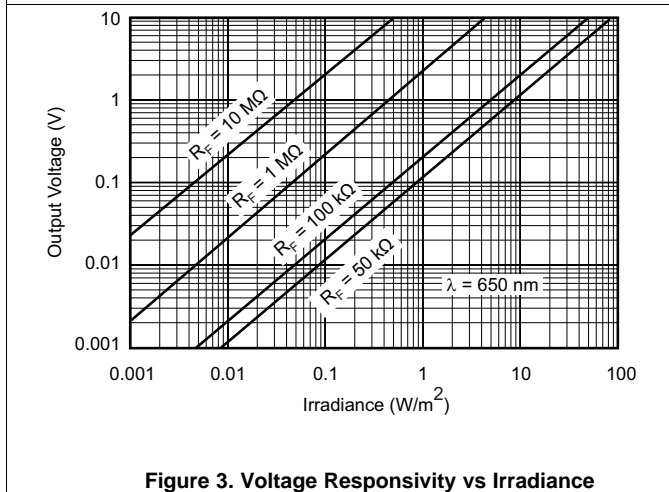

Figure 3. Voltage Responsivity vs Irradiance

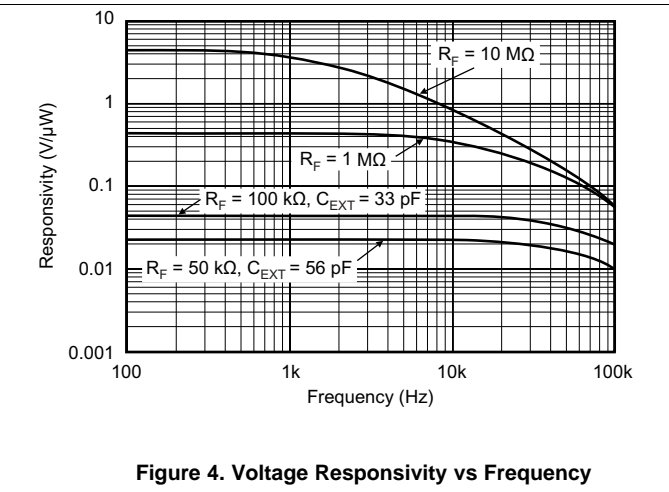

Figure 4. Voltage Responsivity vs Frequency

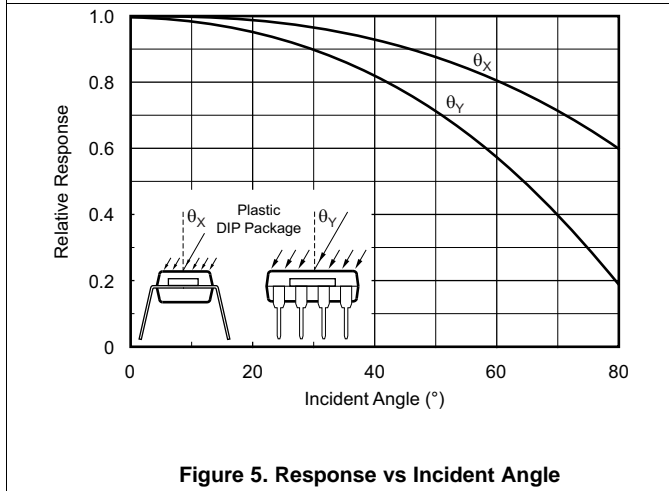

Figure 5. Response vs Incident Angle

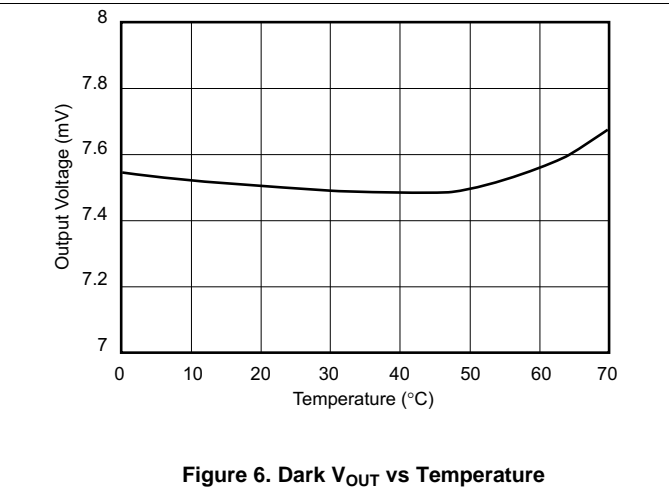

Figure 6. Dark V_{OUT} vs Temperature

Typical Characteristics (continued)

At $T_A = 25^\circ\text{C}$, $V_S = 2.7\text{ V}$ to 36 V , $\lambda = 650\text{ nm}$, internal $1\text{-M}\Omega$ feedback resistor, and $R_L = 10\text{ k}\Omega$ (unless otherwise noted)

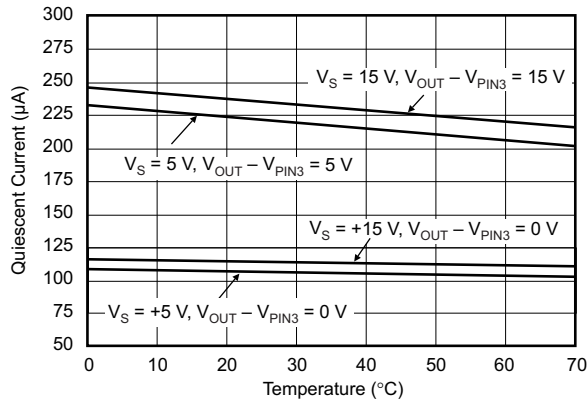

Figure 7. Quiescent Current vs Temperature

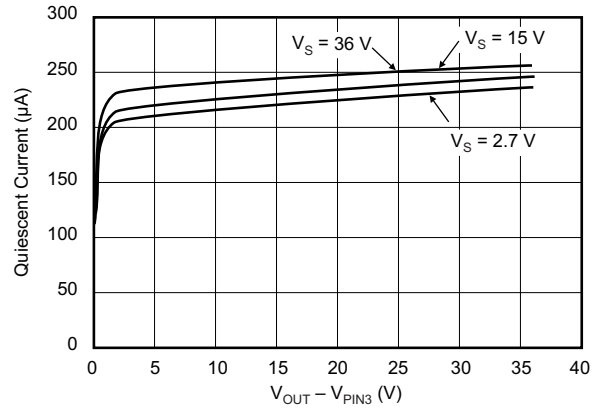

Figure 8. Quiescent Current vs ($V_{OUT} - V_{PIN3}$)

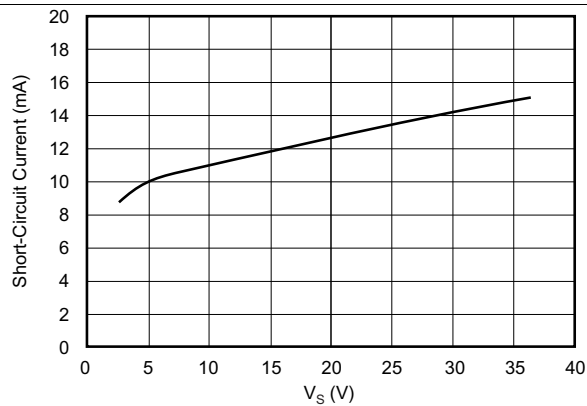

Figure 9. Short-Circuit Current vs V_S

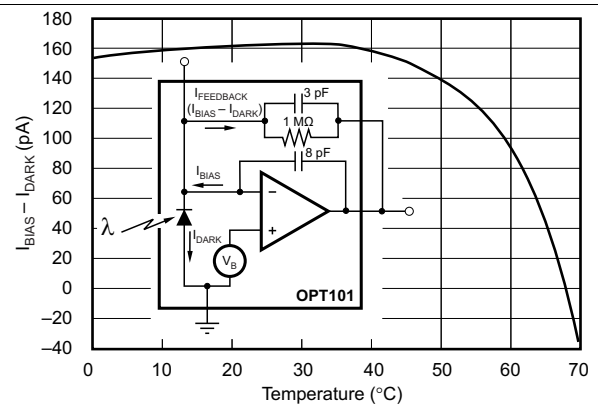

Figure 10. ($I_{BIAS} - I_{DARK}$) vs Temperature

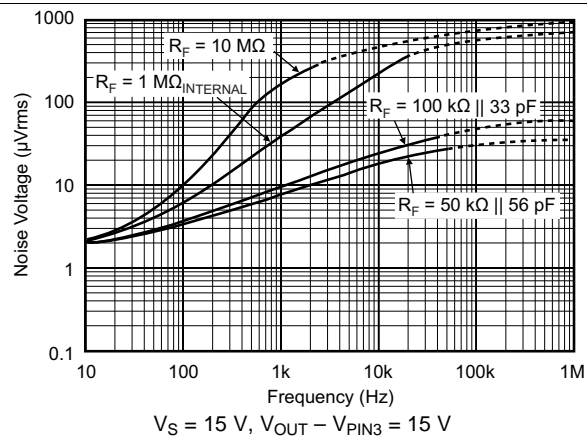

Figure 11. Output Noise Voltage vs Measurement Bandwidth

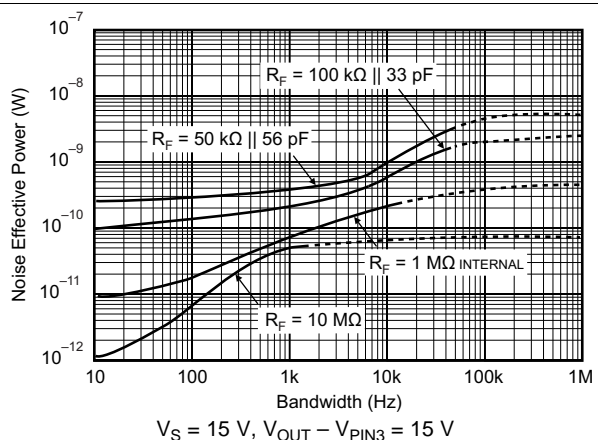

Figure 12. Noise Effective Power vs Measurement Bandwidth

Typical Characteristics (continued)

At $T_A = 25^\circ\text{C}$, $V_S = 2.7\text{ V to }36\text{ V}$, $\lambda = 650\text{ nm}$, internal $1\text{-M}\Omega$ feedback resistor, and $R_L = 10\text{ k}\Omega$ (unless otherwise noted)

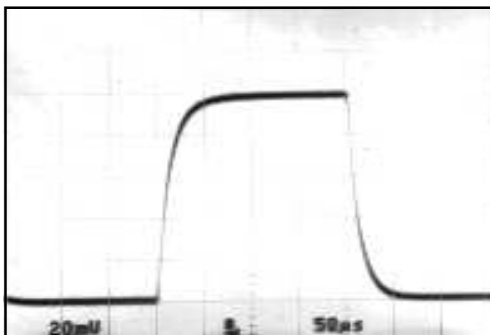
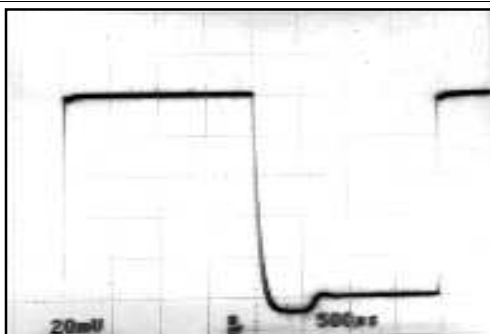

Figure 13. Small-Signal Response

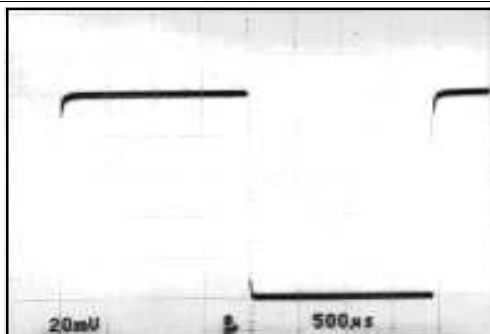

Figure 14. Large-Signal Response



$C_{LOAD} = 10,000\text{ pF}$, pin 3 = 0 V

Figure 15. Small-Signal Response



$C_{LOAD} = 10,000\text{ pF}$, Pin 3 = -15 V

Figure 16. Small-Signal Response

7 Parameter Measurement Information

7.1 Light Source Positioning and Uniformity

The OPT101 is tested with a light source that uniformly illuminates the full area of the integrated circuit, including the op amp. Although the silicon of integrated circuit (IC) amplifiers is light-sensitive to some degree, the OPT101 op amp circuitry is designed to minimize this effect. Sensitive junctions are shielded with metal, and the photodiode area is very large relative to the op amp input circuitry.

If the light source is focused to a small area, be sure that it is properly aimed to fall on the photodiode. A narrowly-focused beam falling only on the photodiode provides improved settling times compared to a source that uniformly illuminates the full area of the die. If a narrowly-focused light source misses the photodiode area and falls only on the op amp circuitry, the OPT101 does not perform properly. The large 0.09-in × 0.09-in (2.29 mm × 2.29 mm) photodiode area allows easy positioning of narrowly-focused light sources. The photodiode area is easily visible because the area appears very dark compared to the surrounding active circuitry.

The incident angle of the light source also effects the apparent sensitivity in uniform irradiance. For small incident angles, the loss in sensitivity is simply due to the smaller effective light gathering area of the photodiode (proportional to the cosine of the angle). At a greater incident angle, light is diffracted and scattered by the package. These effects are shown in [Figure 5](#).

8 Detailed Description

8.1 Overview

The OPT101 is a large-area photodiode integrated with an optimized operational amplifier that makes the OPT101 a small, easy-to-use, light-to-voltage device. The photodiode has a very large measurement area that collects a significant amount of light, and thus allows for high-sensitivity measurements. The photodiode has a wide spectral response with a maximum peak in the infrared spectrum, and a useable range from 300 nm to 1100 nm. The wide power-supply range of 2.7 V to 36 V makes this device useful in a variety of architectures; from all-analog circuits to data conversion base circuits. The on-chip voltage source keeps the amplifier in a good operating region, even at low light levels.

The OPT101 voltage output is the product of the photodiode current times the feedback resistor, ($I_D R_F$), plus a pedestal voltage, V_B , of approximately 7.5 mV introduced for single-supply operation. Output is 7.5 mV dc with no light, and increases with increasing illumination. Photodiode current, I_D , is proportional to the radiant power, or flux, (in watts) falling on the photodiode. At a wavelength of 650 nm (visible red) the photodiode responsivity, R_I , is approximately 0.45 A/W. Responsivity at other wavelengths is shown in [Figure 1](#). The internal feedback resistor is laser trimmed to 1 M Ω . Using this resistor, the output voltage responsivity, R_V , is approximately 0.45 V/ μ W at 650-nm wavelength.

See [Figure 2](#) for the response throughout a wide range of radiant power in microwatts. [Figure 3](#) shows the response throughout a wide range of irradiance in watts per square meter.

8.2 Functional Block Diagram

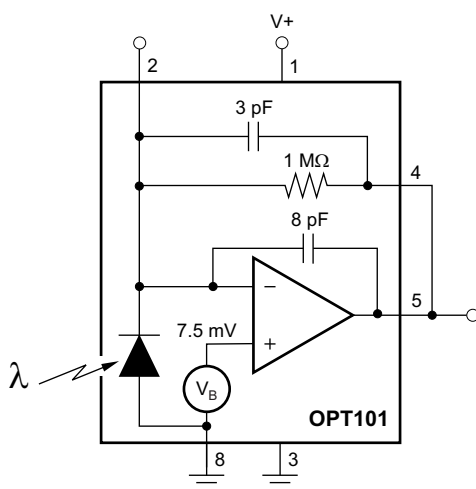

8.3 Feature Description

8.3.1 Dark Performance

The dark errors in the [Electrical Characteristics](#) table include all sources. The dominant source of dark output voltage is the pedestal voltage applied to the noninverting input of the op amp. This voltage is introduced to provide linear operation in the absence of light falling on the photodiode. Photodiode dark current is approximately 2.5 pA, and contributes virtually no offset error at room temperature. The bias current of the op amp summing junction (negative input) is approximately 165 pA. The dark current is subtracted from the amplifier bias current, and this residual current flows through the feedback resistor creating an offset. The effects of temperature on this difference current are seen in [Figure 10](#). The dark output voltage is trimmed to zero with the optional circuit shown in [Figure 17](#). Use a low-impedance offset driver (op amp) to drive pin 8 (Common) because this node has signal-dependent currents.

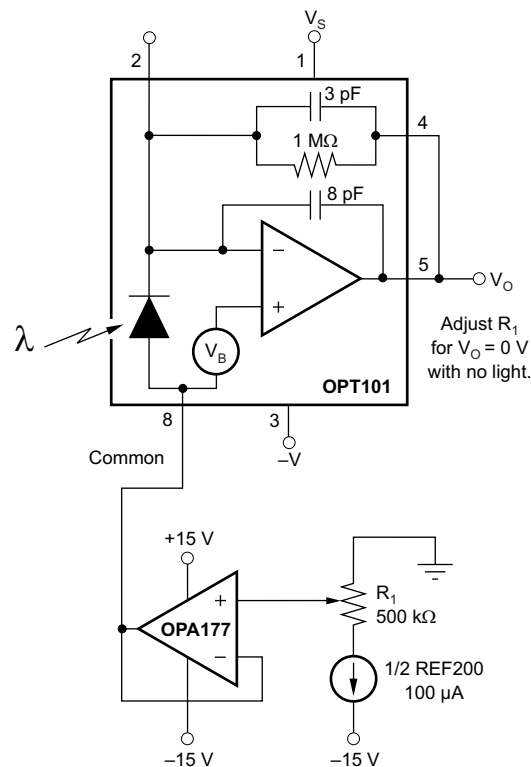

Figure 17. Dark Error (Offset) Adjustment Circuit

Feature Description (continued)

8.3.2 Feedback Network and Dynamic Response

The OPT101 features a feedback network for optimal dynamic response. The dynamic response of the OPT101 is dominated by the feedback network and op amp combination. Using the internal 1-M Ω resistor, the dynamic response of the photodiode and op amp combination can be modeled as a simple RC circuit with a –3-dB cutoff frequency of approximately 14 kHz. The R and C values are 1 M Ω and 11 pF, respectively. To improve the frequency response, use external resistors with less than 3-pF parasitic capacitance. An external 1-M Ω resistor used in the configuration shown in Figure 19 creates a 23-kHz bandwidth with the same 106 V/A dc transimpedance gain. This increased bandwidth yields a rise time of approximately 15 μ s (10% to 90%). Dynamic response is not limited by op amp slew rate, as demonstrated in Figure 13 and Figure 14, showing virtually identical large-signal and small-signal response.

Dynamic response varies with feedback network value, as shown in Figure 4. Rise time (10% to 90%) varies as a function of the –3-dB bandwidth produced by the feedback network value shown in Equation 1:

$$t_r = 0.35 / f_c$$

where

- t_r is the rise time (10% to 90%)
 - f_c is the –3dB bandwidth
- (1)

8.3.2.1 Changing Responsivity

To set a different voltage responsivity, connect an external resistor, R_{EXT}. To increase the responsivity, place this resistor in series with the internal 1-M Ω resistor (Figure 18), or replace the internal resistor with an external resistor by not connecting pin 4 (Figure 19). The second configuration also reduces the circuit gain below 106 V/A when using external resistors that are less than 1 M Ω .

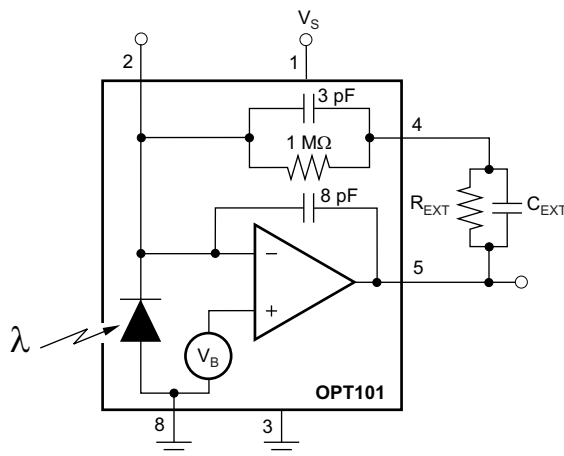

Figure 18. Changing Responsivity with External Resistor in Series with Internal Resistor

Table 1. Responsivity and Bandwidth for Figure 18

R _{EXT} (M Ω)	C _{EXT} (pF)	DC Gain ($\times 10^6$ V/A)	Bandwidth (kHz)
1	50	2	8
2	25	3	6
5	10	6	2.5
10	5	11	1.3
50	—	51	0.33

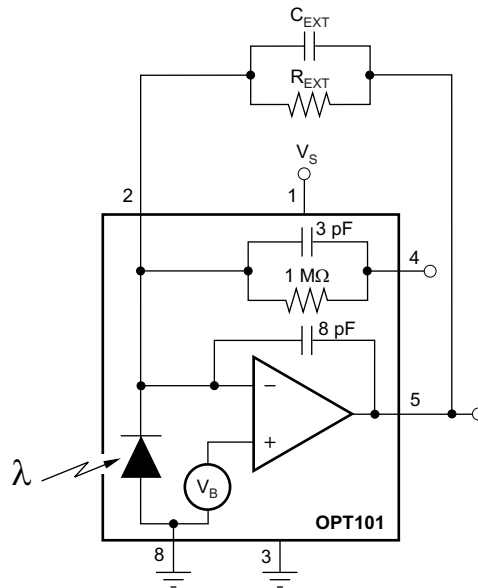

Figure 19. Changing Responsivity with External Resistor Only (Internal Resistor Disabled)

Table 2. Responsivity and Bandwidth for Figure 19

R_{EXT} (MΩ)	C_{EXT} (pF)	DC Gain ($\times 10^6$ V/A)	Bandwidth (kHz)
0.05 ⁽¹⁾	56	0.05	58
0.1 ⁽¹⁾	33	0.1	44
1	—	1	23
2	—	2	9.4
5	—	5	3.6
10	—	10	1.8
50	—	50	0.34

(1) May require 1 kΩ in series with pin 5 when driving large capacitances.

Applications using a feedback resistor significantly larger than the internal 1-MΩ resistor require special consideration. Input bias current of the op amp and dark current of the photodiode increase significantly at higher temperatures. This increase combined with the higher gain ($R_F > 1 \text{ M}\Omega$) can cause the op amp output to be driven to ground at high temperatures. If this problem occurs, use a positive bias voltage applied to pin 8 to make sure that the op amp output remains in the linear operating region when the photodiode is not exposed to light. Alternatively, use a dual power supply. The output may be negative when sensing dark conditions. Use the information discussed in the [Dark Performance](#) section and [Figure 10](#) to analyze the desired configuration.

8.3.3 Noise Performance

Noise performance of the OPT101 is determined by the op amp characteristics, feedback network, photodiode capacitance, and signal level. [Figure 11](#) shows how the noise varies with R_F and measured bandwidth (0.1 Hz to the indicated frequency), when the output voltage minus the voltage on pin 3 (–V) is greater than approximately 50 mV. Below this level, the output stage is powered down, and the effective bandwidth is decreased. This decreased bandwidth reduces the noise to approximately 1/3 the nominal noise value of 300 μV_{rms} , or 100 μV_{rms} . This decreased bandwidth enables a low-level signal to be resolved.

To reduce noise and improve the signal-to-noise ratio, filter the output with a cutoff frequency equal to the signal bandwidth. In addition, output noise increases in proportion to the square root of the feedback resistance, while responsivity increases linearly with feedback resistance. To improve the signal-to-noise ratio performance, use large feedback resistance, if decreased bandwidth is acceptable to the application.

The noise performance of the photodetector is sometimes characterized by noise effective power (NEP), the radiant power that produces an output signal equal to the noise level. NEP has the units of radiant power (watts), or $W/\sqrt{\text{Hz}}$ to convey spectral information about the noise. Figure 12 illustrates the NEP for the OPT101.

8.3.4 Linearity Performance

The photodiode is operated in the photoconductive mode so the current output of the photodiode is very linear with radiant power throughout a wide range. Nonlinearity remains less than approximately 0.05% for photodiode currents less than 100- μA . The photodiode is able to produce output currents of 1 mA or greater with high radiant power, but nonlinearity increases to several percent in this region.

This very linear performance at high radiant power assumes that the full photodiode area is uniformly illuminated. If the light source is focused to a small area of the photodiode, nonlinearity occurs at lower radiant power.

8.3.5 Capacitive Load Drive

The OPT101 is capable of driving load capacitances of 10 nF without instability. However, dynamic performance with capacitive loads may improve by applying a negative bias voltage to pin 3 (-V, shown in Figure 20). This negative power-supply voltage allows the output to go negative in response to the reactive effect of a capacitive load. An internal JFET connected between pin 5 (output) and pin 3 (-V) allows the output to sink current. This current sink capability is also useful when driving the capacitive inputs of some analog-to-digital converters that require the signal source to sink currents up to approximately 100 μA . The benefits of this current sink are shown in Figure 15 and Figure 16. These figures compare operation with pin 3 (-V) grounded and connected to -15 V.

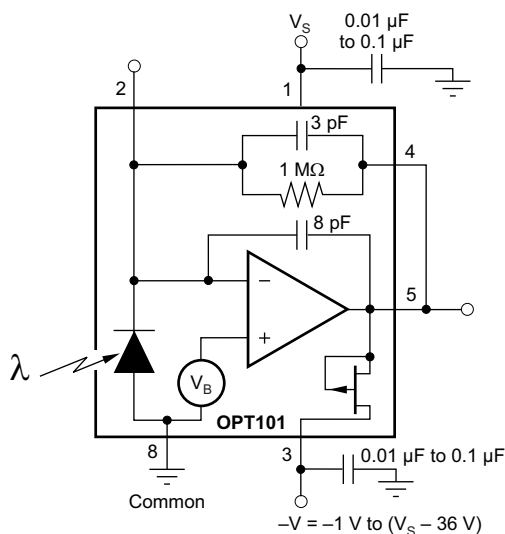

Figure 20. Bipolar Power-Supply Circuit Connections

Because of the architecture of this output stage current sink, there is a slight increase in operating current when there is a voltage between pin 3 (-V) and the output. Depending on the magnitude of this voltage, the quiescent current increases by approximately 100 μA , as shown in Figure 8.

8.4 Device Functional Modes

The OPT101 has a single functional mode and is operational when the power-supply voltage is greater than 2.7 V. The maximum power supply voltage for the OPT101 is 36 V.

9 Application and Implementation

NOTE

Information in the following applications sections is not part of the TI component specification, and TI does not warrant its accuracy or completeness. TI's customers are responsible for determining suitability of components for their purposes. Customers should validate and test their design implementation to confirm system functionality.

9.1 Application Information

Figure 21 shows the basic circuit connections for the OPT101 operating with a single power supply and using the internal 1-M Ω feedback resistor for a response of 0.45 V/ μ W at 650 nm. Pin 3 (–V) is connected to common in this configuration. Applications with high-impedance power supplies may require decoupling capacitors located close to the device pins as shown.

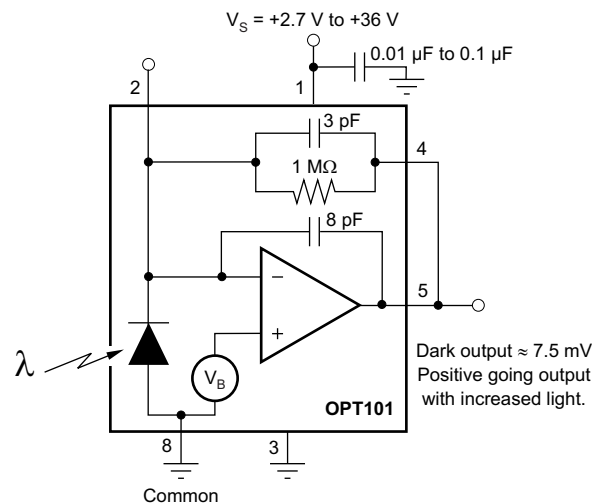

Figure 21. Basic Circuit Connections

9.2 Typical Applications

9.2.1 Color and Reflective Wavelength Tester

A common application for the OPT101 is testing physical materials. Information can be gained about a test material by determining the optical reflection, transmission, or absorption properties at particular wavelengths. These test materials can be solid objects, biological or chemical liquids, or any other type of material.

For an intuitive example, this application for OPT101 tests red, green, and blue reflective color properties of a variety of test materials. This application is not intended to match the color standards as defined by the Commission Internationale de l'Eclairage (CIE), but to illustrate a generic optical wavelength-specific test technique. Different applications can test for different wavelengths, including invisible ultraviolet or infrared wavelengths, that are appropriate for the objective of that application.

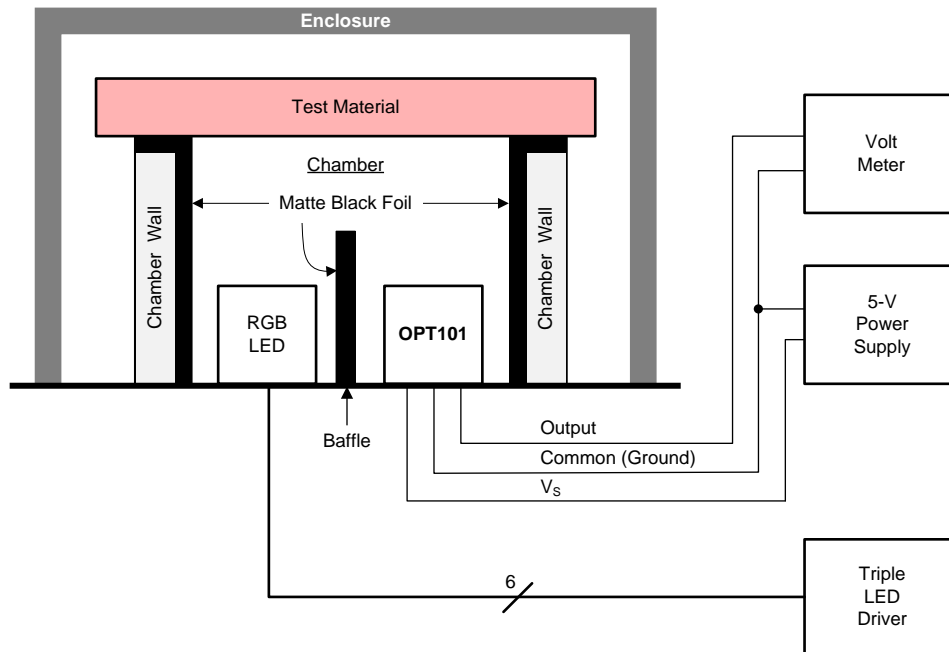

Figure 22. Fixture for Measurement of Optical Reflective Properties of a Test Material

9.2.1.1 Design Requirements

For this design example, use the parameters listed in Table 3 as the input design requirement parameters.

Table 3. Design Parameters

DESIGN PARAMETER	VALUE
Input power supply voltage	5 V
Room ambient light condition	< 2000 lux
Ratio of blue and green response to red response, for red target	< 60%
Ratio of red and green response to blue response, for blue target	< 60%
Ratio of red and blue response to green response, for green target	< 80%

9.2.1.2 Detailed Design Procedure

This design illuminates a test material with specific wavelengths, and measures the resulting reflection. Choose an RGB LED that sequentially creates individual red, green, and blue wavelengths. Red material has a strong reflection of red wavelengths, and a weaker reflection of green and blue wavelengths. Green and blue materials follow a similar pattern, reflecting the respective primary color wavelengths stronger than other color wavelengths.

Design a fixture with a chamber that allows the RGB LED to illuminate the test material and allows the OPT101 to receive the resulting reflection, as shown in [Figure 22](#). Design the chamber to keep out ambient light from the room. Line the chamber with a matte black foil so that the chamber walls absorb as much light as possible. The matte black foil helps the OPT101 sensor measure reflections primarily from the test material and only minimally from the chamber walls. Design a baffle structure between the RGB LED and the OPT101 sensor so that light does not transmit directly from the RGB LED to the OPT101 sensor without reflecting off of the test material. Place an additional enclosure over the chamber to enhance the isolation from any light in the room.

Drive the OPT101 power supply pin, V_S , with a 5-V power supply, and measure the output pin voltage with a voltmeter. This voltmeter can easily be replaced with an ADC.

Choose LED drive currents for each of the RGB LEDs. Throughout this procedure, either drive each LED with this specific chosen current, or do not drive the LED at all. Choose an LED drive current that equalizes the power dissipation (the drive current times the forward-biased voltage drop across each LED). This equal power dissipation minimizes thermal transient settling time when switching between the LEDs. This equal power dissipation is not a requirement if test speed and settling time are not an issue for the application.

Calibrate the fixture by measuring a standard white card as a test material. Drive the red LED, and record the resulting voltage from the OPT101. Repeat this procedure with the green and blue LEDs.

Next, measure a test material with the same procedure used for the white card. Normalize the results by dividing the test material result by the white card result for each LED. Determine the color of the object by selecting the largest of the three LED normalized measurements. Perform an additional normalization step for data clarity by dividing each of the three LED measurements by the largest of the three measurements.

9.2.1.3 Application Curves

The following figures show that the colors of the test materials sorted properly, as expected. The red test materials all showed a stronger reflection for red LED than the green and blue LEDs. The results are plotted in four groups: red (Figure 23, blue (Figure 24), green (Figure 25), and neutral color (Figure 26). The application clearly identifies the primary color of each test material. When the color is neutral, then the red, green, and blue test results are very similar to each other, as expected (within 10% of each other).

The red results had the most contrast. The green results had the least contrast. These results are likely different because the red LED has the least spectral overlap with the green and blue LEDs. The green LED has the widest spectral content. If more contrast is required, try LEDs (or other light sources) with more-narrow spectrums.

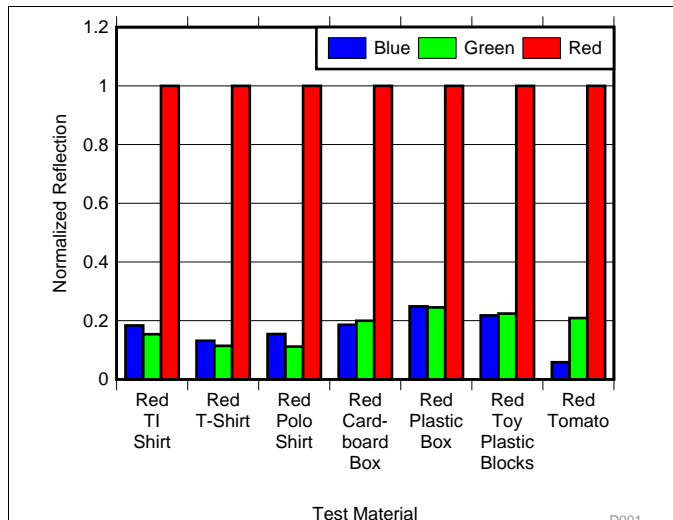

Figure 23. Normalized Reflections for Red Materials

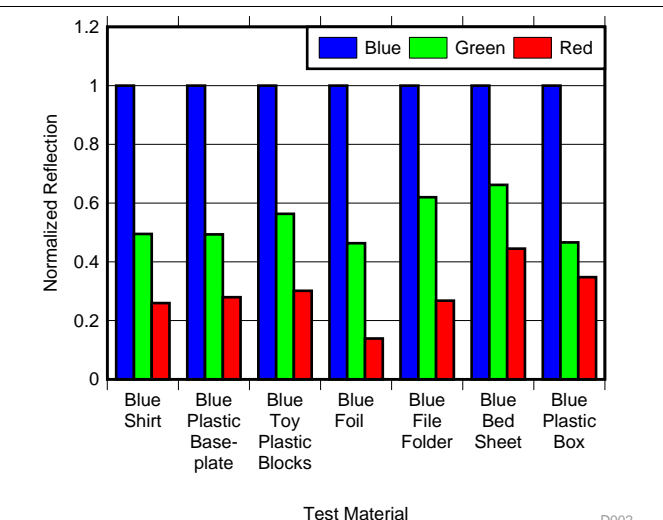

Figure 24. Normalized Reflections for Blue Materials

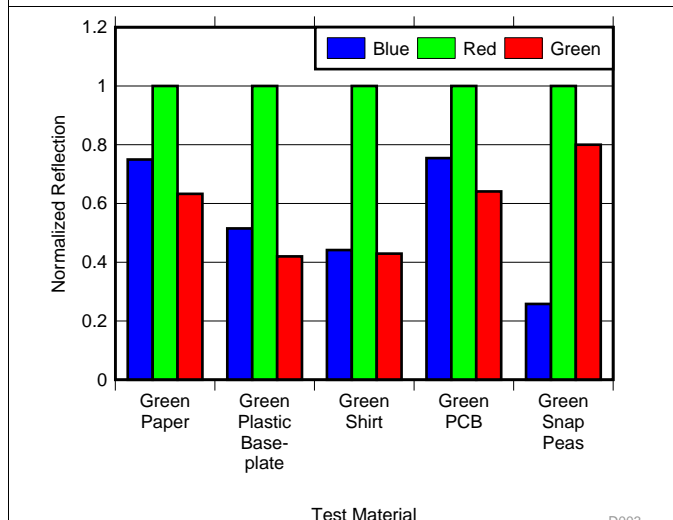

Figure 25. Normalized Reflections for Green Materials

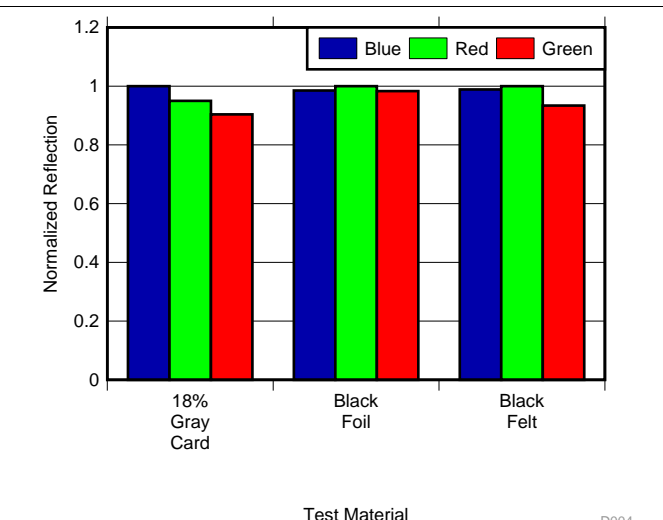

Figure 26. Normalized Reflections for Neutral Materials

9.2.2 Three-Wire Remote Light Measurement

Use the connections to the OPT101 shown on the right side of [Figure 27](#) to sense a remote location with a three-wire light measurement circuit.

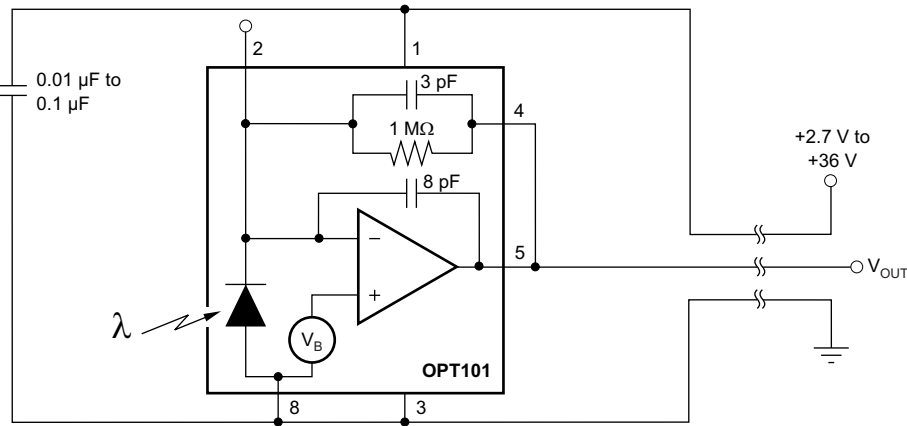

Figure 27. Three-Wire Remote Light Measurement

9.2.3 Differential Light Measurement

Use a configuration similar to [Figure 28](#) for applications that sense light gradients or differential light.

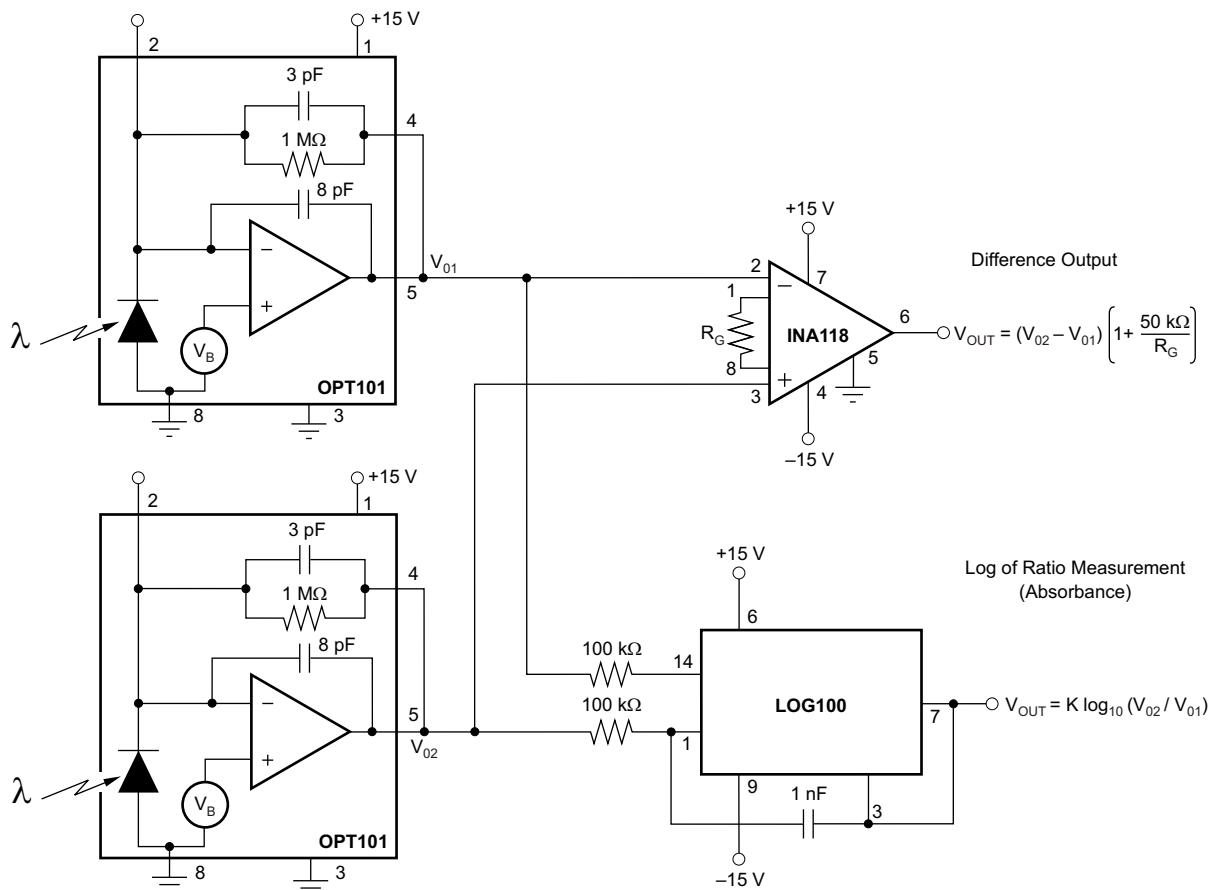

Figure 28. Differential Light Measurement

9.3 Dos and Don'ts

As with any optical product, special care must be taken into consideration when handling the OPT101. Although the OPT101 has low sensitivity to dust and scratches, proper optical device handling procedures are still recommended.

The optical surface of the device must be kept clean for optimal performance in both prototyping with the device and mass production manufacturing procedures. Tweezers with plastic or rubber contact surfaces are recommended to avoid scratches on the optical surface. Avoid manipulation with metal tools when possible. The optical surface must be kept clean of fingerprints, dust, and other optical-inhibiting contaminants.

If the device optical surface requires cleaning, use deionized water or isopropyl alcohol. A few gentile brushes with a soft swab are appropriate. Avoid potentially abrasive cleaning and manipulating tools and excessive force that can scratch the optical surface.

If the OPT101 performs less than optimally, inspect the optical surface for dirt, scratches, or other optical artifacts.

Any light falling on the op amp circuitry area must be uniform; see the [Parameter Measurement Information](#) section for more information about light uniformity.

10 Power-Supply Recommendations

The OPT101 is designed to operate from an input voltage supply range between 2.7 V and 36 V. Make sure the power-supply input is well regulated. Place a 0.01- μ F to 0.1- μ F bypass capacitor with low-impedance, short connections between V_S (pin 1) and $-V$ (pin 3). If $-V$ (pin 3) is not connected to Common (pin 8), place an additional bypass capacitor between V_S (pin 1) and Common (pin 8).

11 Layout

11.1 Layout Guidelines

Make all power connections with short, low impedance connections.

Depending on the application, the design might benefit from having the OPT101 mounted to the opposite side of the board as the other electrical components. Keeping the optical sensor side free from extra components allows for easier mounting of any required optical-mechanical structures around the OPT101.

11.2 Layout Example

The following example shows an external feedback network (R2 and C2) that bypasses the internal feedback network, similar to Figure 19. This example also shows an external feedback network (R1, C1) in series with the internal feedback network, similar to Figure 18. To use only the internal feedback network, load R1 or C1 with a short circuit. This example allows for three different configurations with the same layout. Do not load R1, C1, R2, and C2 simultaneously.

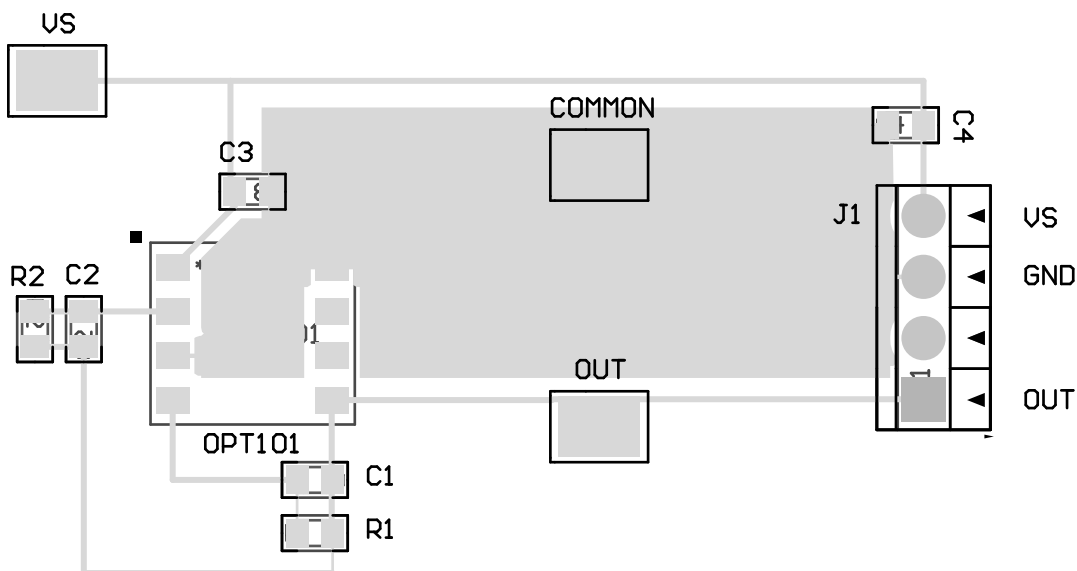

Figure 30. Layout Example

12 Device and Documentation Support

12.1 Community Resources

The following links connect to TI community resources. Linked contents are provided "AS IS" by the respective contributors. They do not constitute TI specifications and do not necessarily reflect TI's views; see TI's [Terms of Use](#).

TI E2E™ Online Community *TI's Engineer-to-Engineer (E2E) Community*. Created to foster collaboration among engineers. At e2e.ti.com, you can ask questions, share knowledge, explore ideas and help solve problems with fellow engineers.

Design Support *TI's Design Support* Quickly find helpful E2E forums along with design support tools and contact information for technical support.

12.2 Trademarks

E2E is a trademark of Texas Instruments.
All other trademarks are the property of their respective owners.

12.3 Electrostatic Discharge Caution



These devices have limited built-in ESD protection. The leads should be shorted together or the device placed in conductive foam during storage or handling to prevent electrostatic damage to the MOS gates.

12.4 Moisture Sensitivity and Soldering

Clear plastic does not contain the structural-enhancing fillers used in black plastic molding compound. As a result, clear plastic is more sensitive to environmental stress than black plastic. This can cause difficulties if devices have been stored in high humidity prior to soldering. The rapid heating during soldering can stress wire bonds and cause failures. Prior to soldering, it is recommended that plastic devices be baked-out at 85°C for 24 hours.

The fire-retardant fillers used in black plastic are not compatible with clear molding compound. The OPT101 plastic packages cannot meet flammability test, UL-94.

12.5 Glossary

[SLYZ022](#) — *TI Glossary*.

This glossary lists and explains terms, acronyms, and definitions.

13 Mechanical, Packaging, and Orderable Information

The following pages include mechanical, packaging, and orderable information. This information is the most current data available for the designated devices. This data is subject to change without notice and revision of this document. For browser-based versions of this data sheet, refer to the left-hand navigation.

PACKAGING INFORMATION

Orderable Device	Status (1)	Package Type	Package Drawing	Pins	Package Qty	Eco Plan (2)	Lead/Ball Finish (6)	MSL Peak Temp (3)	Op Temp (°C)	Device Marking (4/5)	Samples
OPT101P	ACTIVE	PDIP	NTC	8	50	Green (RoHS & no Sb/Br)	CU NIPDAU	N / A for Pkg Type		OPT101	Samples
OPT101P-J	ACTIVE	SOP	DTL	8	50	Green (RoHS & no Sb/Br)	CU NIPDAU	Level-4-250C-72 HR		OPT101	Samples
OPT101P-JG4	ACTIVE	SOP	DTL	8	50	Green (RoHS & no Sb/Br)	CU NIPDAU	Level-4-250C-72 HR		OPT101	Samples
OPT101PG4	ACTIVE	PDIP	NTC	8	50	Green (RoHS & no Sb/Br)	CU NIPDAU	N / A for Pkg Type		OPT101	Samples

(1) The marketing status values are defined as follows:

ACTIVE: Product device recommended for new designs.

LIFEBUY: TI has announced that the device will be discontinued, and a lifetime-buy period is in effect.

NRND: Not recommended for new designs. Device is in production to support existing customers, but TI does not recommend using this part in a new design.

PREVIEW: Device has been announced but is not in production. Samples may or may not be available.

OBSOLETE: TI has discontinued the production of the device.

(2) Eco Plan - The planned eco-friendly classification: Pb-Free (RoHS), Pb-Free (RoHS Exempt), or Green (RoHS & no Sb/Br) - please check <http://www.ti.com/productcontent> for the latest availability information and additional product content details.

TBD: The Pb-Free/Green conversion plan has not been defined.

Pb-Free (RoHS): TI's terms "Lead-Free" or "Pb-Free" mean semiconductor products that are compatible with the current RoHS requirements for all 6 substances, including the requirement that lead not exceed 0.1% by weight in homogeneous materials. Where designed to be soldered at high temperatures, TI Pb-Free products are suitable for use in specified lead-free processes.

Pb-Free (RoHS Exempt): This component has a RoHS exemption for either 1) lead-based flip-chip solder bumps used between the die and package, or 2) lead-based die adhesive used between the die and leadframe. The component is otherwise considered Pb-Free (RoHS compatible) as defined above.

Green (RoHS & no Sb/Br): TI defines "Green" to mean Pb-Free (RoHS compatible), and free of Bromine (Br) and Antimony (Sb) based flame retardants (Br or Sb do not exceed 0.1% by weight in homogeneous material)

(3) MSL, Peak Temp. - The Moisture Sensitivity Level rating according to the JEDEC industry standard classifications, and peak solder temperature.

(4) There may be additional marking, which relates to the logo, the lot trace code information, or the environmental category on the device.

(5) Multiple Device Markings will be inside parentheses. Only one Device Marking contained in parentheses and separated by a "~" will appear on a device. If a line is indented then it is a continuation of the previous line and the two combined represent the entire Device Marking for that device.

(6) Lead/Ball Finish - Orderable Devices may have multiple material finish options. Finish options are separated by a vertical ruled line. Lead/Ball Finish values may wrap to two lines if the finish value exceeds the maximum column width.

Important Information and Disclaimer: The information provided on this page represents TI's knowledge and belief as of the date that it is provided. TI bases its knowledge and belief on information provided by third parties, and makes no representation or warranty as to the accuracy of such information. Efforts are underway to better integrate information from third parties. TI has taken and continues to take reasonable steps to provide representative and accurate information but may not have conducted destructive testing or chemical analysis on incoming materials and chemicals. TI and TI suppliers consider certain information to be proprietary, and thus CAS numbers and other limited information may not be available for release.

In no event shall TI's liability arising out of such information exceed the total purchase price of the TI part(s) at issue in this document sold by TI to Customer on an annual basis.

NTC (R-PDIP-T8)

PLASTIC DUAL-IN-LINE

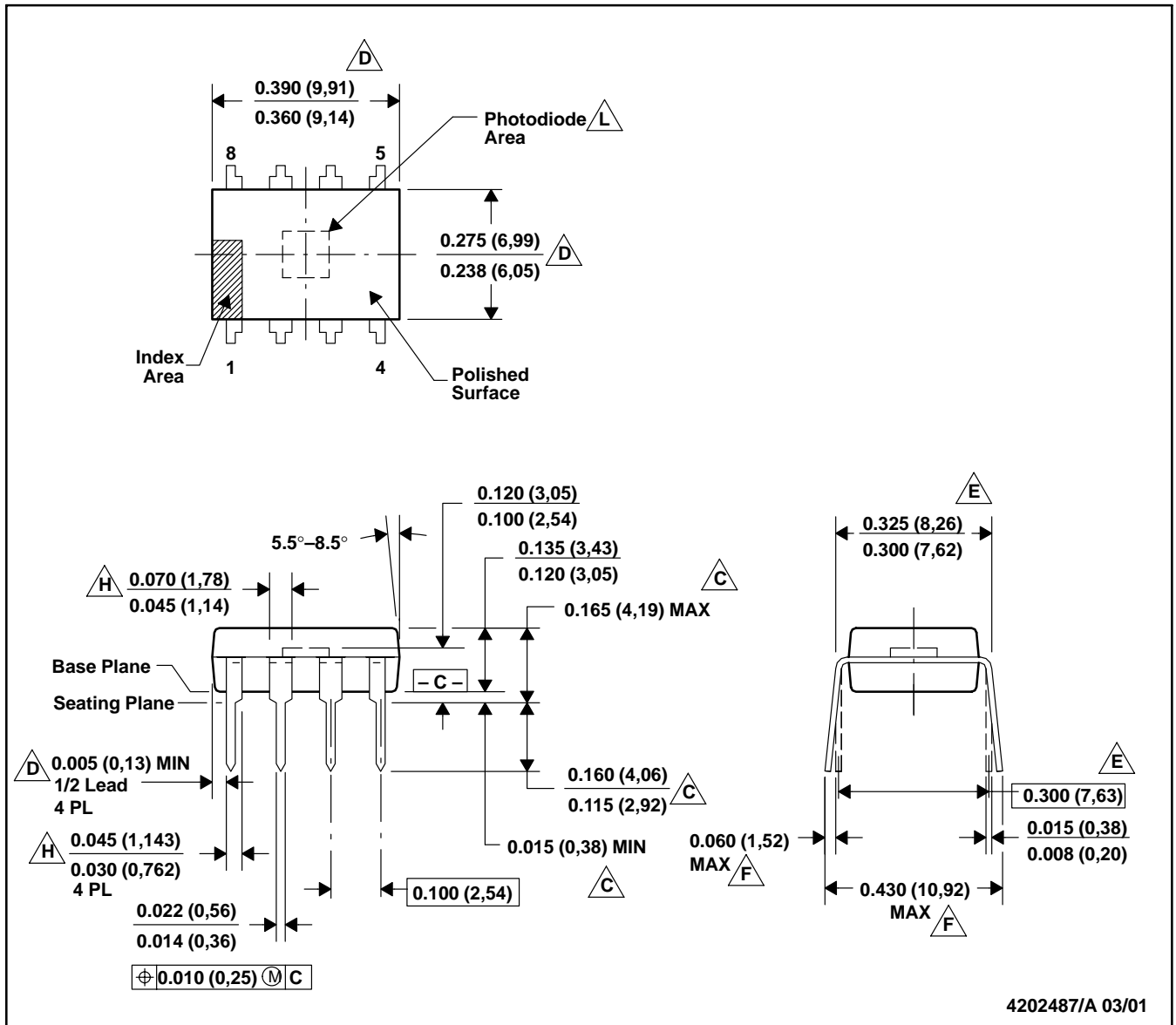

- NOTES: A. All linear dimensions are in inches (millimeters).
 B. This drawing is subject to change without notice.
 C. Dimensions are measured with the package seated in JEDEC seating plane gauge GS-3.
 D. Dimensions do not include mold flash or protrusions. Mold flash or protrusions shall not exceed 0.010 (0,25).
 E. Dimensions measured with the leads constrained to be perpendicular to Datum C.
 F. Dimensions are measured at the lead tips with the leads unconstrained.
 G. Pointed or rounded lead tips are preferred to ease insertion.
 H. Maximum dimensions do not include dambar protrusions. Dambar protrusions shall not exceed 0.010 (0,25).
 I. Distance between leads including dambar protrusions to be 0.005 (0,13) minimum.
 J. A visual index feature must be located within the cross-hatched area.
 K. For automatic insertion, any raised irregularity on the top surface (step, mesa, etc.) shall be symmetrical about the lateral and longitudinal package centerlines.
 L. Center of photodiode must be within 0.010 (0,25) of center of photodiode area

DTL0008A



PACKAGE OUTLINE

SOP - 4.95 mm max height

PLASTIC SMALL OUTLINE

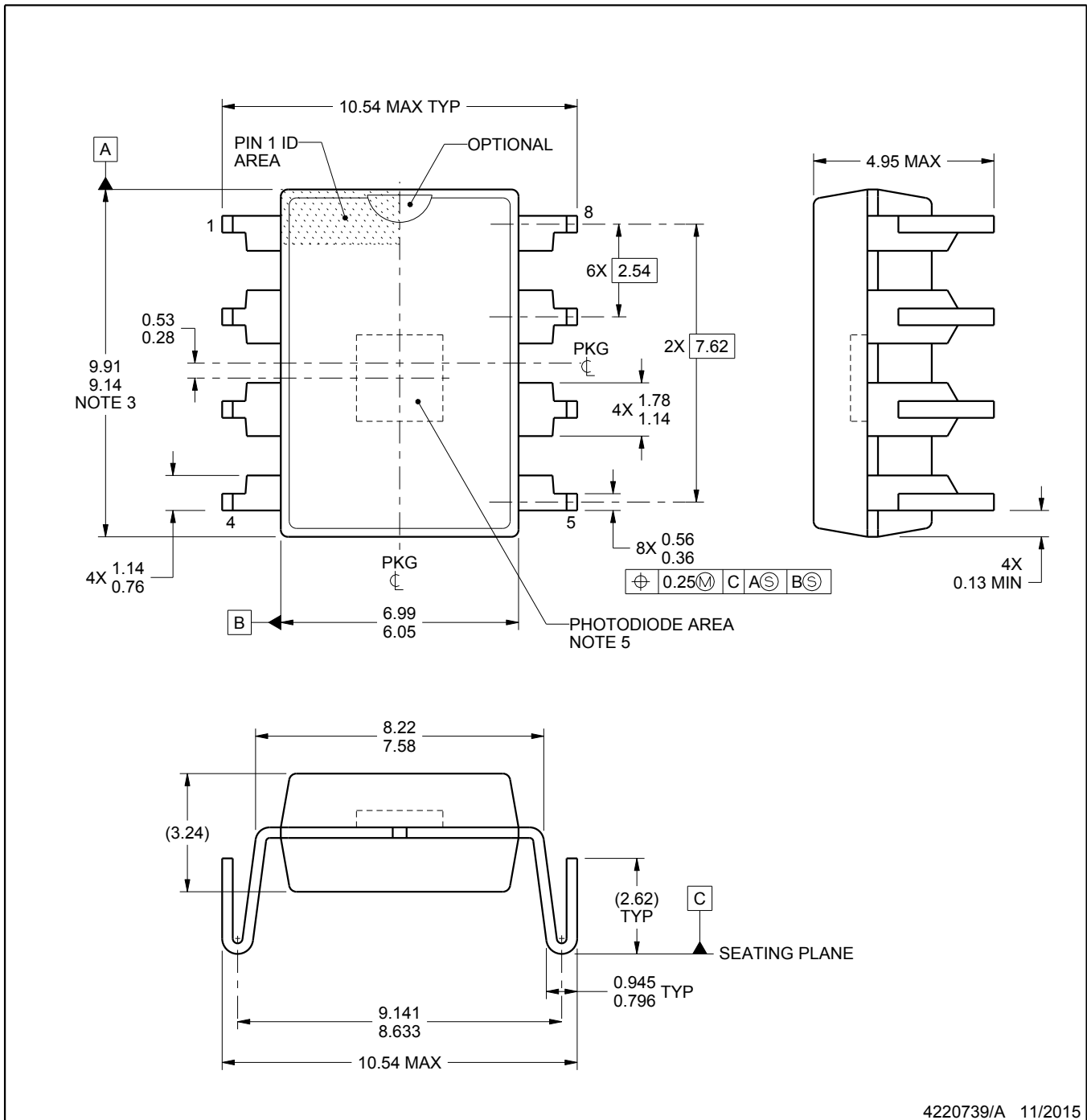

4220739/A 11/2015

NOTES:

1. All linear dimensions are in millimeters. Dimensions in parenthesis are for reference only. Dimensioning and tolerancing per ASME Y14.5M.
2. This drawing is subject to change without notice.
3. This dimension does not include mold flash, protrusions, or gate burrs. Mold flash, protrusions, or gate burrs shall not exceed 0.25 mm per side.
4. For automatic insertion, any raised irregularity on the top surface (step, mesa, etc.) shall be symmetrical about the lateral and longitudinal package centerlines.
5. Center of the photodiode must be within 0.25 of the center of the photodiode area.
6. The mold compound for this package is clear.

EXAMPLE BOARD LAYOUT

DTL0008A

SOP - 4.95 mm max height

PLASTIC SMALL OUTLINE

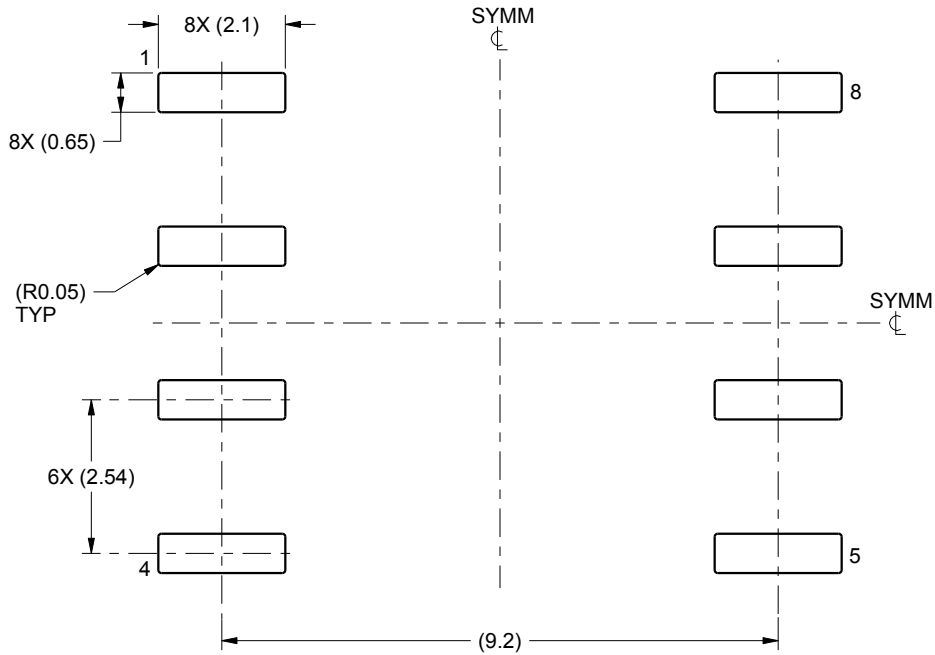

LAND PATTERN EXAMPLE
SCALE:8X

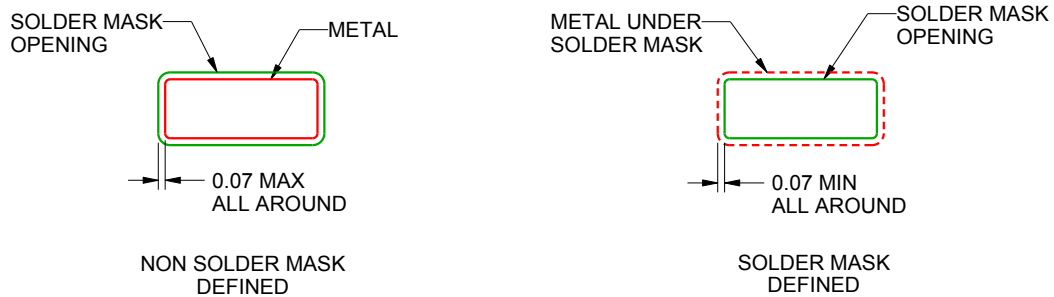

SOLDER MASK DETAILS

4220739/A 11/2015

NOTES: (continued)

- 7. Publication IPC-7351 may have alternate designs.
- 8. Solder mask tolerances between and around signal pads can vary based on board fabrication site.

EXAMPLE STENCIL DESIGN

DTL0008A

SOP - 4.95 mm max height

PLASTIC SMALL OUTLINE

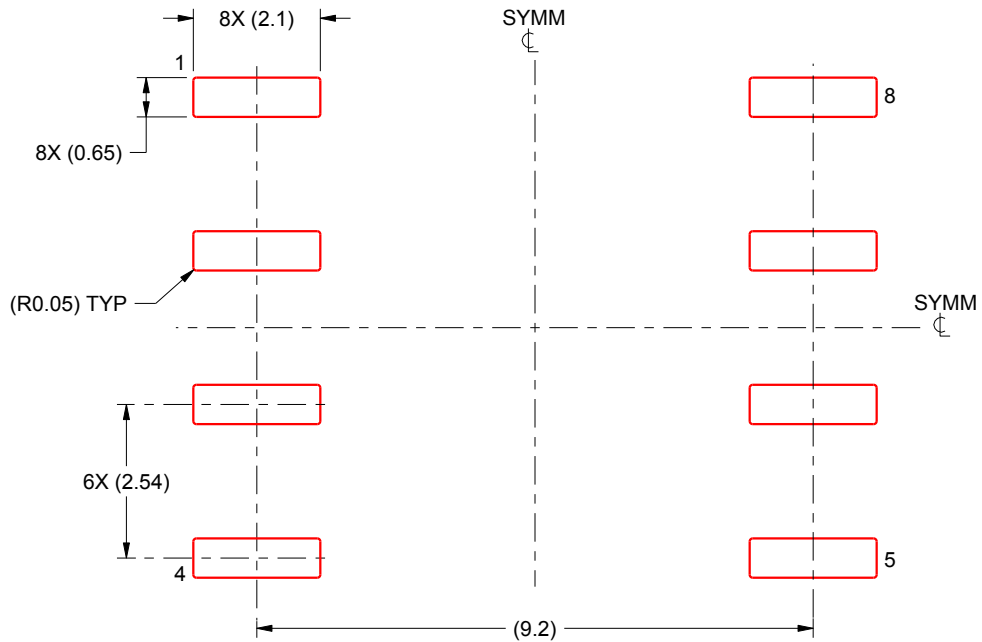

SOLDER PASTE EXAMPLE
BASED ON 0.125 mm THICK STENCIL
SCALE:8X

4220739/A 11/2015

NOTES: (continued)

9. Laser cutting apertures with trapezoidal walls and rounded corners may offer better paste release. IPC-7525 may have alternate design recommendations.
10. Board assembly site may have different recommendations for stencil design.

IMPORTANT NOTICE

Texas Instruments Incorporated and its subsidiaries (TI) reserve the right to make corrections, enhancements, improvements and other changes to its semiconductor products and services per JESD46, latest issue, and to discontinue any product or service per JESD48, latest issue. Buyers should obtain the latest relevant information before placing orders and should verify that such information is current and complete. All semiconductor products (also referred to herein as "components") are sold subject to TI's terms and conditions of sale supplied at the time of order acknowledgment.

TI warrants performance of its components to the specifications applicable at the time of sale, in accordance with the warranty in TI's terms and conditions of sale of semiconductor products. Testing and other quality control techniques are used to the extent TI deems necessary to support this warranty. Except where mandated by applicable law, testing of all parameters of each component is not necessarily performed.

TI assumes no liability for applications assistance or the design of Buyers' products. Buyers are responsible for their products and applications using TI components. To minimize the risks associated with Buyers' products and applications, Buyers should provide adequate design and operating safeguards.

TI does not warrant or represent that any license, either express or implied, is granted under any patent right, copyright, mask work right, or other intellectual property right relating to any combination, machine, or process in which TI components or services are used. Information published by TI regarding third-party products or services does not constitute a license to use such products or services or a warranty or endorsement thereof. Use of such information may require a license from a third party under the patents or other intellectual property of the third party, or a license from TI under the patents or other intellectual property of TI.

Reproduction of significant portions of TI information in TI data books or data sheets is permissible only if reproduction is without alteration and is accompanied by all associated warranties, conditions, limitations, and notices. TI is not responsible or liable for such altered documentation. Information of third parties may be subject to additional restrictions.

Resale of TI components or services with statements different from or beyond the parameters stated by TI for that component or service voids all express and any implied warranties for the associated TI component or service and is an unfair and deceptive business practice. TI is not responsible or liable for any such statements.

Buyer acknowledges and agrees that it is solely responsible for compliance with all legal, regulatory and safety-related requirements concerning its products, and any use of TI components in its applications, notwithstanding any applications-related information or support that may be provided by TI. Buyer represents and agrees that it has all the necessary expertise to create and implement safeguards which anticipate dangerous consequences of failures, monitor failures and their consequences, lessen the likelihood of failures that might cause harm and take appropriate remedial actions. Buyer will fully indemnify TI and its representatives against any damages arising out of the use of any TI components in safety-critical applications.

In some cases, TI components may be promoted specifically to facilitate safety-related applications. With such components, TI's goal is to help enable customers to design and create their own end-product solutions that meet applicable functional safety standards and requirements. Nonetheless, such components are subject to these terms.

No TI components are authorized for use in FDA Class III (or similar life-critical medical equipment) unless authorized officers of the parties have executed a special agreement specifically governing such use.

Only those TI components which TI has specifically designated as military grade or "enhanced plastic" are designed and intended for use in military/aerospace applications or environments. Buyer acknowledges and agrees that any military or aerospace use of TI components which have **not** been so designated is solely at the Buyer's risk, and that Buyer is solely responsible for compliance with all legal and regulatory requirements in connection with such use.

TI has specifically designated certain components as meeting ISO/TS16949 requirements, mainly for automotive use. In any case of use of non-designated products, TI will not be responsible for any failure to meet ISO/TS16949.

Products

Audio	www.ti.com/audio
Amplifiers	amplifier.ti.com
Data Converters	dataconverter.ti.com
DLP® Products	www.dlp.com
DSP	dsp.ti.com
Clocks and Timers	www.ti.com/clocks
Interface	interface.ti.com
Logic	logic.ti.com
Power Mgmt	power.ti.com
Microcontrollers	microcontroller.ti.com
RFID	www.ti-rfid.com
OMAP Applications Processors	www.ti.com/omap
Wireless Connectivity	www.ti.com/wirelessconnectivity

Applications

Automotive and Transportation	www.ti.com/automotive
Communications and Telecom	www.ti.com/communications
Computers and Peripherals	www.ti.com/computers
Consumer Electronics	www.ti.com/consumer-apps
Energy and Lighting	www.ti.com/energy
Industrial	www.ti.com/industrial
Medical	www.ti.com/medical
Security	www.ti.com/security
Space, Avionics and Defense	www.ti.com/space-avionics-defense
Video and Imaging	www.ti.com/video

TI E2E Community

e2e.ti.com