

DUAL BIDIRECTIONAL I²C BUS AND SMBus VOLTAGE-LEVEL TRANSLATOR

Check for Samples: [PCA9306-Q1](#)

FEATURES

- Qualified for Automotive Applications
- AEC-Q100 Qualified With the Following Results:
 - Device Temperature Grade 2: –40°C to 105°C
 - Device HBM ESD Classification Level H2
 - Device CDM ESD Classification Level C4B
- 2-Bit Bidirectional Translator for SDA and SCL Lines in Mixed-Mode I²C Applications
- I²C and SMBus Compatible
- Less Than 1.5-ns Maximum Propagation Delay to Accommodate Standard-Mode and Fast-Mode I²C Devices and Multiple Masters
- Allows Voltage-Level Translation Between
 - 1.2-V V_{REF1} and 1.8-V, 2.5-V, 3.3-V, or 5-V V_{REF2}
 - 1.8-V V_{REF1} and 2.5-V, 3.3-V or 5-V V_{REF2}
 - 2.5-V V_{REF1} and 3.3-V or 5-V V_{REF2}
 - 3.3-V V_{REF1} and 5-V V_{REF2}
- Provides Bidirectional Voltage Translation With No Direction Pin
- Low 3.5-Ω ON-State Connection Between Input and Output Ports Provides Less Signal Distortion
- Open-Drain I²C I/O Ports (SCL1, SDA1, SCL2, and SDA2)
- 5-V Tolerant I²C I/O Ports to Support Mixed-Mode Signal Operation
- High-Impedance SCL1, SDA1, SCL2, and SDA2 Pins for EN = Low
- Lock-Up-Free Operation for Isolation When EN = Low
- Flow-Through Pinout for Ease of Printed Circuit Board Trace Routing
- Latch-Up Performance Exceeds 100 mA Per JESD 78, Class II
- ESD Protection Exceeds JESD 22
 - 2000-V Human-Body Model (A114-A)
 - 200-V Machine Model (A115-A)
 - 1000-V Charged-Device Model (C101)

DCU PACKAGE
(TOP VIEW)

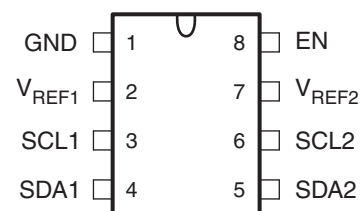

PIN	SYMBOL	FUNCTION
1	GND	Ground, 0 V
2	V_{REF1}	Low-voltage-side reference supply voltage for SCL1 and SDA1
3	SCL1	Serial clock, low-voltage side. Connect to V_{REF1} through a pullup resistor.
4	SDA1	Serial data, low-voltage side. Connect to V_{REF1} through a pullup resistor.
5	SDA2	Serial data, high-voltage side. Connect to V_{REF2} through a pullup resistor.
6	SCL2	Serial clock, high-voltage side. Connect to V_{REF2} through a pullup resistor.
7	V_{REF2}	High-voltage-side reference supply voltage for SCL2 and SDA2
8	EN	Switch enable input. Connected to V_{REF2} and pulled up through a high resistor.



Please be aware that an important notice concerning availability, standard warranty, and use in critical applications of Texas Instruments semiconductor products and disclaimers thereto appears at the end of this data sheet.

DESCRIPTION

This dual bidirectional I²C and SMBus voltage-level translator, with an enable (EN) input, is operational from 1.2-V to 3.3-V V_{REF1} and 1.8-V to 5.5-V V_{REF2} .

The PCA9306 allows bidirectional voltage translations between 1.2 V and 5 V, without the use of a direction pin. The low ON-state resistance (r_{on}) of the switch allows connections to be made with minimal propagation delay. When EN is high, the translator switch is ON, and the SCL1 and SDA1 I/O are connected to the SCL2 and SDA2 I/O, respectively, allowing bidirectional data flow between ports. When EN is low, the translator switch is off, and a high-impedance state exists between ports.

In I²C applications, the bus capacitance limit of 400 pF restricts the number of devices and bus length. Using the PCA9306 enables the system designer to isolate two halves of a bus; thus, more I²C devices or longer trace length can be accommodated.

The PCA9306 also can be used to run two buses, one at 400-kHz operating frequency and the other at 100-kHz operating frequency. If the two buses are operating at different frequencies, the 100-kHz bus must be isolated when the 400-kHz operation of the other bus is required. If the master is running at 400 kHz, the maximum system operating frequency may be less than 400 kHz because of the delays added by the repeater.

As with the standard I²C system, pullup resistors are required to provide the logic high levels on the translator's bus. The PCA9306 has a standard open-collector configuration of the I²C bus. The size of these pullup resistors depends on the system, but each side of the repeater must have a pullup resistor. The device is designed to work with standard-mode and fast-mode I²C devices, in addition to SMBus devices. Standard-mode I²C devices only specify 3 mA in a generic I²C system where standard-mode devices and multiple masters are possible. Under certain conditions, high termination currents can be used.

When the SDA1 or SDA2 port is low, the clamp is in the ON state, and a low resistance connection exists between the SDA1 and SDA2 ports. Assuming the higher voltage is on the SDA2 port when the SDA2 port is high, the voltage on the SDA1 port is limited to the voltage set by V_{REF1} . When the SDA1 port is high, the SDA2 port is pulled to the drain pullup supply voltage (V_{DPU}) by the pullup resistors. This functionality allows a seamless translation between higher and lower voltages selected by the user, without the need for directional control. The SCL1/SCL2 channel also functions as the SDA1/SDA2 channel.

All channels have the same electrical characteristics, and there is minimal deviation from one output to another in voltage or propagation delay. This is a benefit over discrete transistor voltage translation solutions, since the fabrication of the switch is symmetrical. The translator provides excellent ESD protection to lower-voltage devices and at the same time protects less ESD-resistant devices.



This integrated circuit can be damaged by ESD. Texas Instruments recommends that all integrated circuits be handled with appropriate precautions. Failure to observe proper handling and installation procedures can cause damage.

ESD damage can range from subtle performance degradation to complete device failure. Precision integrated circuits may be more susceptible to damage because very small parametric changes could cause the device not to meet its published specifications.

FUNCTION TABLE

INPUT EN ⁽¹⁾	TRANSLATOR FUNCTION
H	SCL1 = SCL2, SDA1 = SDA2
L	Disconnect

(1) EN is controlled by the V_{REF2} logic levels and should be at least 1 V higher than V_{REF1} for best translator operation.

Figure 1. LOGIC DIAGRAM (POSITIVE LOGIC)

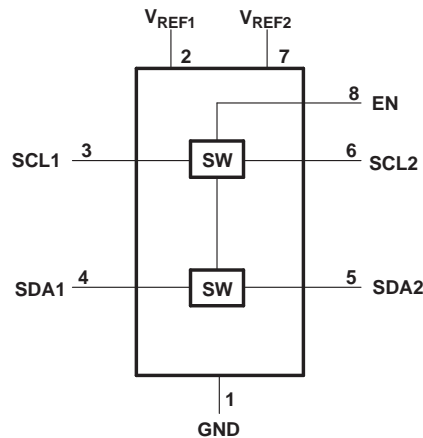

Absolute Maximum Ratings⁽¹⁾

over operating free-air temperature range (unless otherwise noted)

	MIN	MAX	UNIT
V_{REF1} DC reference voltage range	-0.5	7	V
V_{REF2} DC reference bias voltage range	-0.5	7	V
V_I Input voltage range ⁽²⁾	-0.5	7	V
$V_{I/O}$ Input/output voltage range ⁽²⁾	-0.5	7	V
Continuous channel current		128	mA
I_{IK} Input clamp current	$V_I < 0$		-50 mA
θ_{JA} Package thermal impedance ⁽³⁾		227	°C/W
T_{stg} Storage temperature range	-65	150	°C
ESD Electrostatic discharge rating	Human-body model H2		2 kV
	Charged-device model C4B		750 V

(1) Stresses beyond those listed under "absolute maximum ratings" may cause permanent damage to the device. These are stress ratings only, and functional operation of the device at these or any other conditions beyond those indicated under "recommended operating conditions" is not implied. Exposure to absolute-maximum-rated conditions for extended periods may affect device reliability.

(2) The input and input/output negative voltage ratings may be exceeded if the input and output current ratings are observed.

(3) The package thermal impedance is calculated in accordance with JEDEC 51-7.

Recommended Operating Conditions

	MIN	MAX	UNIT
$V_{I/O}$ Input/output voltage	SCL1, SDA1, SCL2, SDA2		0 5 V
V_{REF1} Reference voltage	0	5	V

Recommended Operating Conditions (continued)

		MIN	MAX	UNIT
V _{REF2}	Reference voltage	0	5	V
EN	Enable input voltage	0	5	V
I _{PASS}	Pass switch current		64	mA
T _A	Operating free-air temperature	-40	105	°C

Electrical Characteristics

over recommended operating free-air temperature range (unless otherwise noted)

PARAMETER		TEST CONDITIONS		MIN	TYP ⁽¹⁾	MAX	UNIT		
V _{IK}	Input clamp voltage	I _I = -18 mA,	EN = 0 V			-1.2	V		
I _{IH}	Input leakage current	V _I = 5 V,	EN = 0 V			5	μA		
C _i (EN)	Input capacitance	V _I = 3 V or 0			11		pF		
C _{io(off)}	Off capacitance	SCLn, SDAn	V _O = 3 V or 0, EN = 0 V		4	6	pF		
C _{io(on)}	On capacitance	SCLn, SDAn	V _O = 3 V or 0, EN = 3 V		10.5	12.5	pF		
r _{on} ⁽²⁾	ON-state resistance	SCLn, SDAn	V _I = 0,	I _O = 64 mA	EN = 4.5 V	3.5	5.5	Ω	
					EN = 3 V	4.7	7		
					EN = 2.3 V	6.3	9.5		
					EN = 1.5 V	25.5	32		
			V _I = 2.4 V,	I _O = 15 mA	EN = 4.5 V	1	6		15
					EN = 3 V	20	60		140
V _I = 1.7 V,	I _O = 15 mA	EN = 2.3 V	20	60	140				

(1) All typical values are at T_A = 25°C.

(2) Measured by the voltage drop between the SCL1 and SCL2, or SDA1 and SDA2 terminals, at the indicated current through the switch. On-state resistance is determined by the lowest voltage of the two terminals.

AC PERFORMANCE (TRANSLATING DOWN)

Switching Characteristics

over recommended operating free-air temperature range, EN = 3.3 V, V_{IH} = 3.3 V, V_{IL} = 0, and V_M = 1.15 V (unless otherwise noted) (see [Figure 2](#))

PARAMETER	FROM (INPUT)	TO (OUTPUT)	C _L = 50 pF		C _L = 30 pF		C _L = 15 pF		UNIT
			MIN	MAX	MIN	MAX	MIN	MAX	
t _{PLH}	SCL2 or SDA2	SCL1 or SDA1	0.8		0.6		0.3		ns
t _{PHL}			1.2		1		0.5		

Switching Characteristics

over recommended operating free-air temperature range, EN = 2.5 V, V_{IH} = 2.5 V, V_{IL} = 0, and V_M = 0.75 V (unless otherwise noted) (see [Figure 2](#))

PARAMETER	FROM (INPUT)	TO (OUTPUT)	C _L = 50 pF		C _L = 30 pF		C _L = 15 pF		UNIT
			MIN	MAX	MIN	MAX	MIN	MAX	
t _{PLH}	SCL2 or SDA2	SCL1 or SDA1	1		0.7		0.4		ns
t _{PHL}			1.3		1		0.6		

AC PERFORMANCE (TRANSLATING UP)

Switching Characteristics

over recommended operating free-air temperature range, $V_{EN} = 3.3\text{ V}$, $V_{IH} = 2.3\text{ V}$, $V_{IL} = 0$, $V_T = 3.3\text{ V}$, $V_M = 1.15\text{ V}$, and $R_L = 300\ \Omega$ (unless otherwise noted) (see Figure 2)

PARAMETER	FROM (INPUT)	TO (OUTPUT)	$C_L = 50\text{ pF}$		$C_L = 30\text{ pF}$		$C_L = 15\text{ pF}$		UNIT
			MIN	MAX	MIN	MAX	MIN	MAX	
t_{PLH}	SCL1 or SDA1	SCL2 or SDA2	0.9		0.6		0.4		ns
t_{PHL}			1.4		1.1		0.7		

Switching Characteristics

over recommended operating free-air temperature range, $V_{EN} = 2.5\text{ V}$, $V_{IH} = 1.5\text{ V}$, $V_{IL} = 0$, $V_T = 2.5\text{ V}$, $V_M = 0.75\text{ V}$, and $R_L = 300\ \Omega$ (unless otherwise noted) (see Figure 2)

PARAMETER	FROM (INPUT)	TO (OUTPUT)	$C_L = 50\text{ pF}$		$C_L = 30\text{ pF}$		$C_L = 15\text{ pF}$		UNIT
			MIN	MAX	MIN	MAX	MIN	MAX	
t_{PLH}	SCL1 or SDA1	SCL2 or SDA2	1		0.6		0.4		ns
t_{PHL}			1.3		1.3		0.8		

PARAMETER MEASUREMENT INFORMATION

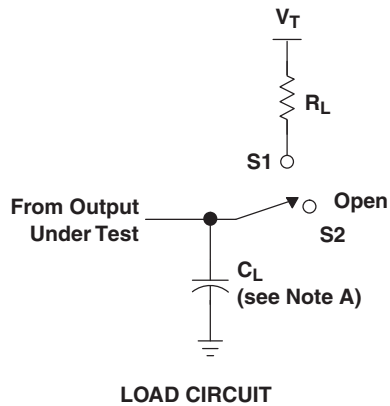

USAGE	SWITCH
Translating up	S1
Translating down	S2

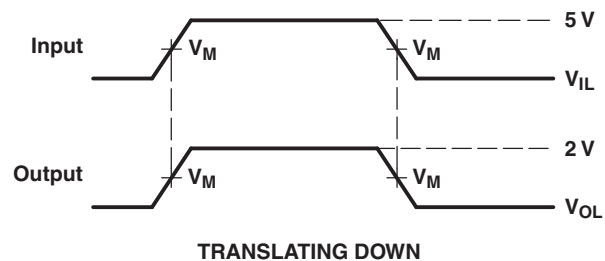
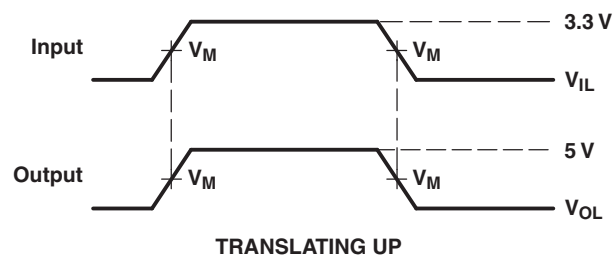

- NOTES: A. C_L includes probe and jig capacitance.
 B. All input pulses are supplied by generators having the following characteristics: $PRR \leq 10\text{ MHz}$, $Z_O = 50\ \Omega$, $t_r \leq 2\text{ ns}$, $t_f \leq 2\text{ ns}$.
 C. The outputs are measured one at a time, with one transition per measurement.

Figure 2. Load Circuit for Outputs

APPLICATION INFORMATION

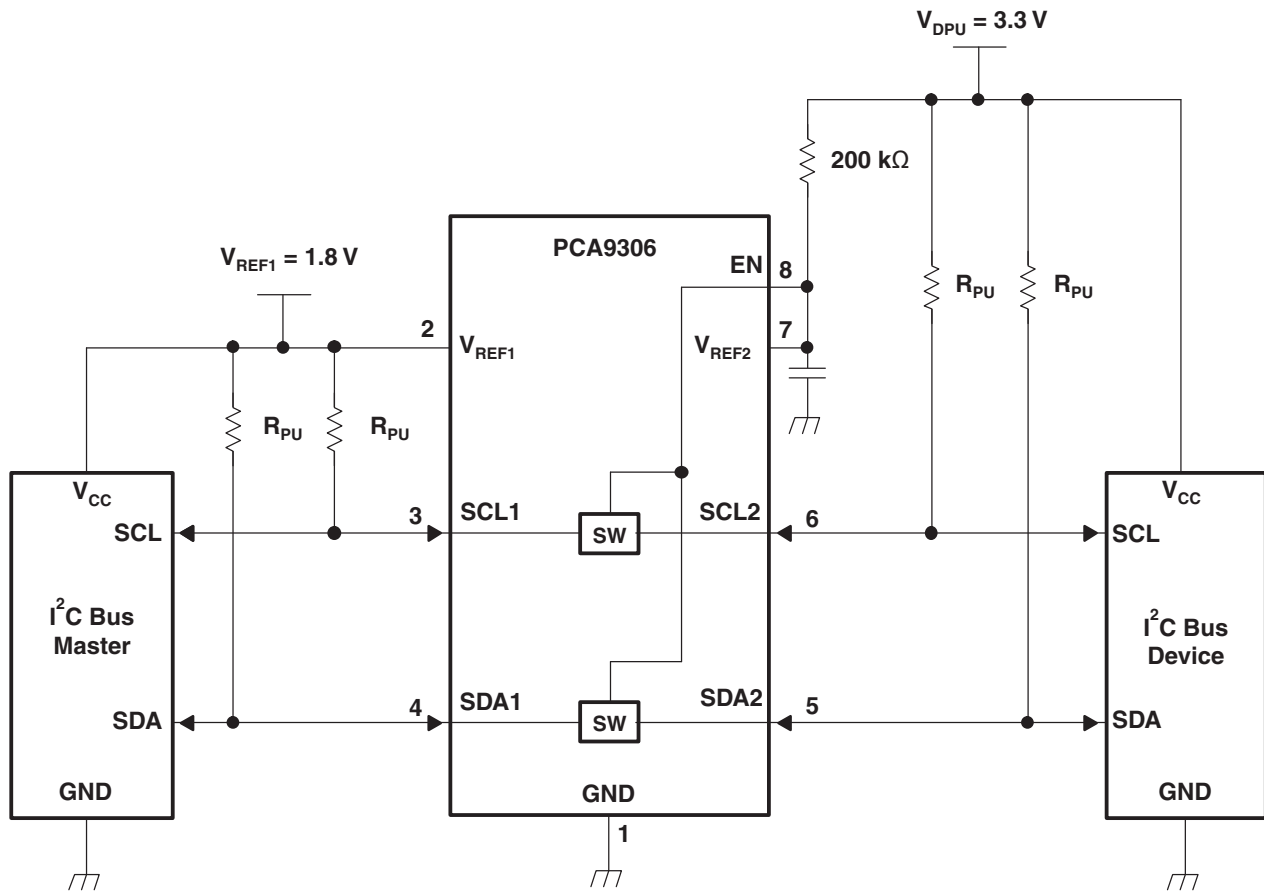

Figure 3. Typical Application Circuit (Switch Always Enabled)

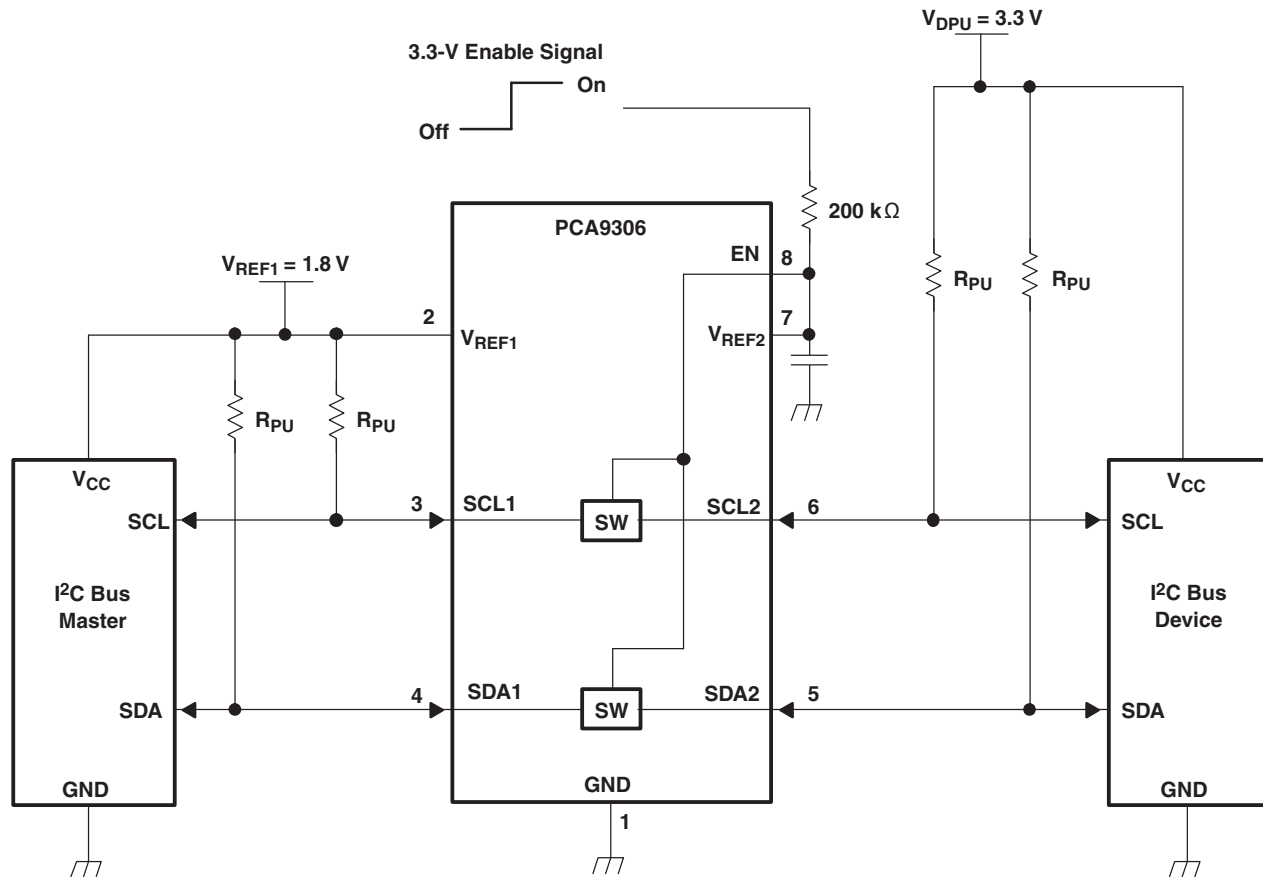

Figure 4. Typical Application Circuit (Switch Enable Control)

Bidirectional Translation

For the bidirectional clamping configuration (higher voltage to lower voltage or lower voltage to higher voltage), the EN input must be connected to V_{REF2} and both pins pulled to high-side V_{DPU} through a pullup resistor (typically 200 k Ω). This allows V_{REF2} to regulate the EN input. A filter capacitor on V_{REF2} is recommended. The I²C bus master output can be totem pole or open drain (pullup resistors may be required) and the I²C bus device output can be totem pole or open drain (pullup resistors are required to pull the SCL2 and SDA2 outputs to V_{DPU}). However, if either output is totem pole, data must be unidirectional or the outputs must be 3-stateable and be controlled by some direction-control mechanism to prevent high-to-low contentions in either direction. If both outputs are open drain, no direction control is needed.

The reference supply voltage (V_{REF1}) is connected to the processor core power-supply voltage.

Application Operating Conditions

see [Figure 3](#)

		MIN	TYP ⁽¹⁾	MAX	UNIT
V _{REF2}	Reference voltage	V _{REF1} + 0.6	2.1	5	V
EN	Enable input voltage	V _{REF1} + 0.6	2.1	5	V
V _{REF1}	Reference voltage	0	1.5	4.4	V
I _{PASS}	Pass switch current		14		mA
I _{REF}	Reference-transistor current		5		μA
T _A	Operating free-air temperature	–40		105	°C

(1) All typical values are at T_A = 25°C.

Sizing Pullup Resistor

The pullup resistor value needs to limit the current through the pass transistor, when it is in the on state, to about 15 mA. This ensures a pass voltage of 260 mV to 350 mV. If the current through the pass transistor is higher than 15 mA, the pass voltage also is higher in the on state. To set the current through each pass transistor at 15 mA, the pullup resistor value is calculated as:

$$R_{PU} = \frac{V_{DPU} - 0.35 \text{ V}}{0.015 \text{ A}}$$

The following table summarizes resistor values, reference voltages, and currents at 15 mA, 10 mA, and 3 mA. The resistor value shown in the +10% column (or a larger value) should be used to ensure that the pass voltage of the transistor is 350 mV or less. The external driver must be able to sink the total current from the resistors on both sides of the PCA9306 device at 0.175 V, although the 15 mA applies only to current flowing through the PCA9306 device.

PULLUP RESISTOR VALUES ^{(1) (2)}

PULLUP RESISTOR VALUE (Ω)						
V _{DPU}	15 mA		10 mA		3 mA	
	NOMINAL	+10% ⁽³⁾	NOMINAL	+10% ⁽³⁾	NOMINAL	+10% ⁽³⁾
5 V	310	341	465	512	1550	1705
3.3 V	197	217	295	325	983	1082
2.5 V	143	158	215	237	717	788
1.8 V	97	106	145	160	483	532
1.5 V	77	85	115	127	383	422
1.2 V	57	63	85	94	283	312

(1) Calculated for V_{OL} = 0.35 V

(2) Assumes output driver V_{OL} = 0.175 V at stated current

(3) +10% to compensate for V_{DD} range and resistor tolerance

PACKAGING INFORMATION

Orderable Device	Status (1)	Package Type	Package Drawing	Pins	Package Qty	Eco Plan (2)	Lead/Ball Finish (6)	MSL Peak Temp (3)	Op Temp (°C)	Device Marking (4/5)	Samples
PCA9306IDCURQ1	ACTIVE	VSSOP	DCU	8	3000	Green (RoHS & no Sb/Br)	CU NIPDAU	Level-1-260C-UNLIM	-40 to 85	CCUS	Samples
PCA9306TDCURQ1	ACTIVE	VSSOP	DCU	8	3000	Green (RoHS & no Sb/Br)	CU NIPDAU	Level-1-260C-UNLIM	-40 to 105	YAAS	Samples

(1) The marketing status values are defined as follows:

ACTIVE: Product device recommended for new designs.

LIFEBUY: TI has announced that the device will be discontinued, and a lifetime-buy period is in effect.

NRND: Not recommended for new designs. Device is in production to support existing customers, but TI does not recommend using this part in a new design.

PREVIEW: Device has been announced but is not in production. Samples may or may not be available.

OBSOLETE: TI has discontinued the production of the device.

(2) Eco Plan - The planned eco-friendly classification: Pb-Free (RoHS), Pb-Free (RoHS Exempt), or Green (RoHS & no Sb/Br) - please check <http://www.ti.com/productcontent> for the latest availability information and additional product content details.

TBD: The Pb-Free/Green conversion plan has not been defined.

Pb-Free (RoHS): TI's terms "Lead-Free" or "Pb-Free" mean semiconductor products that are compatible with the current RoHS requirements for all 6 substances, including the requirement that lead not exceed 0.1% by weight in homogeneous materials. Where designed to be soldered at high temperatures, TI Pb-Free products are suitable for use in specified lead-free processes.

Pb-Free (RoHS Exempt): This component has a RoHS exemption for either 1) lead-based flip-chip solder bumps used between the die and package, or 2) lead-based die adhesive used between the die and leadframe. The component is otherwise considered Pb-Free (RoHS compatible) as defined above.

Green (RoHS & no Sb/Br): TI defines "Green" to mean Pb-Free (RoHS compatible), and free of Bromine (Br) and Antimony (Sb) based flame retardants (Br or Sb do not exceed 0.1% by weight in homogeneous material)

(3) MSL, Peak Temp. - The Moisture Sensitivity Level rating according to the JEDEC industry standard classifications, and peak solder temperature.

(4) There may be additional marking, which relates to the logo, the lot trace code information, or the environmental category on the device.

(5) Multiple Device Markings will be inside parentheses. Only one Device Marking contained in parentheses and separated by a "~" will appear on a device. If a line is indented then it is a continuation of the previous line and the two combined represent the entire Device Marking for that device.

(6) Lead/Ball Finish - Orderable Devices may have multiple material finish options. Finish options are separated by a vertical ruled line. Lead/Ball Finish values may wrap to two lines if the finish value exceeds the maximum column width.

Important Information and Disclaimer: The information provided on this page represents TI's knowledge and belief as of the date that it is provided. TI bases its knowledge and belief on information provided by third parties, and makes no representation or warranty as to the accuracy of such information. Efforts are underway to better integrate information from third parties. TI has taken and continues to take reasonable steps to provide representative and accurate information but may not have conducted destructive testing or chemical analysis on incoming materials and chemicals. TI and TI suppliers consider certain information to be proprietary, and thus CAS numbers and other limited information may not be available for release.

In no event shall TI's liability arising out of such information exceed the total purchase price of the TI part(s) at issue in this document sold by TI to Customer on an annual basis.

OTHER QUALIFIED VERSIONS OF PCA9306-Q1 :

- Catalog: [PCA9306](#)

NOTE: Qualified Version Definitions:

- Catalog - TI's standard catalog product

TAPE AND REEL INFORMATION

QUADRANT ASSIGNMENTS FOR PIN 1 ORIENTATION IN TAPE

*All dimensions are nominal

Device	Package Type	Package Drawing	Pins	SPQ	Reel Diameter (mm)	Reel Width W1 (mm)	A0 (mm)	B0 (mm)	K0 (mm)	P1 (mm)	W (mm)	Pin1 Quadrant
PCA9306IDCURQ1	VSSOP	DCU	8	3000	180.0	8.4	2.25	3.35	1.05	4.0	8.0	Q3
PCA9306TDCURQ1	VSSOP	DCU	8	3000	180.0	8.4	2.25	3.35	1.05	4.0	8.0	Q3

TAPE AND REEL BOX DIMENSIONS

*All dimensions are nominal

Device	Package Type	Package Drawing	Pins	SPQ	Length (mm)	Width (mm)	Height (mm)
PCA9306IDCURQ1	VSSOP	DCU	8	3000	202.0	201.0	28.0
PCA9306TDCURQ1	VSSOP	DCU	8	3000	202.0	201.0	28.0

DCU (S-PDSO-G8)

PLASTIC SMALL OUTLINE PACKAGE (DIE DOWN)

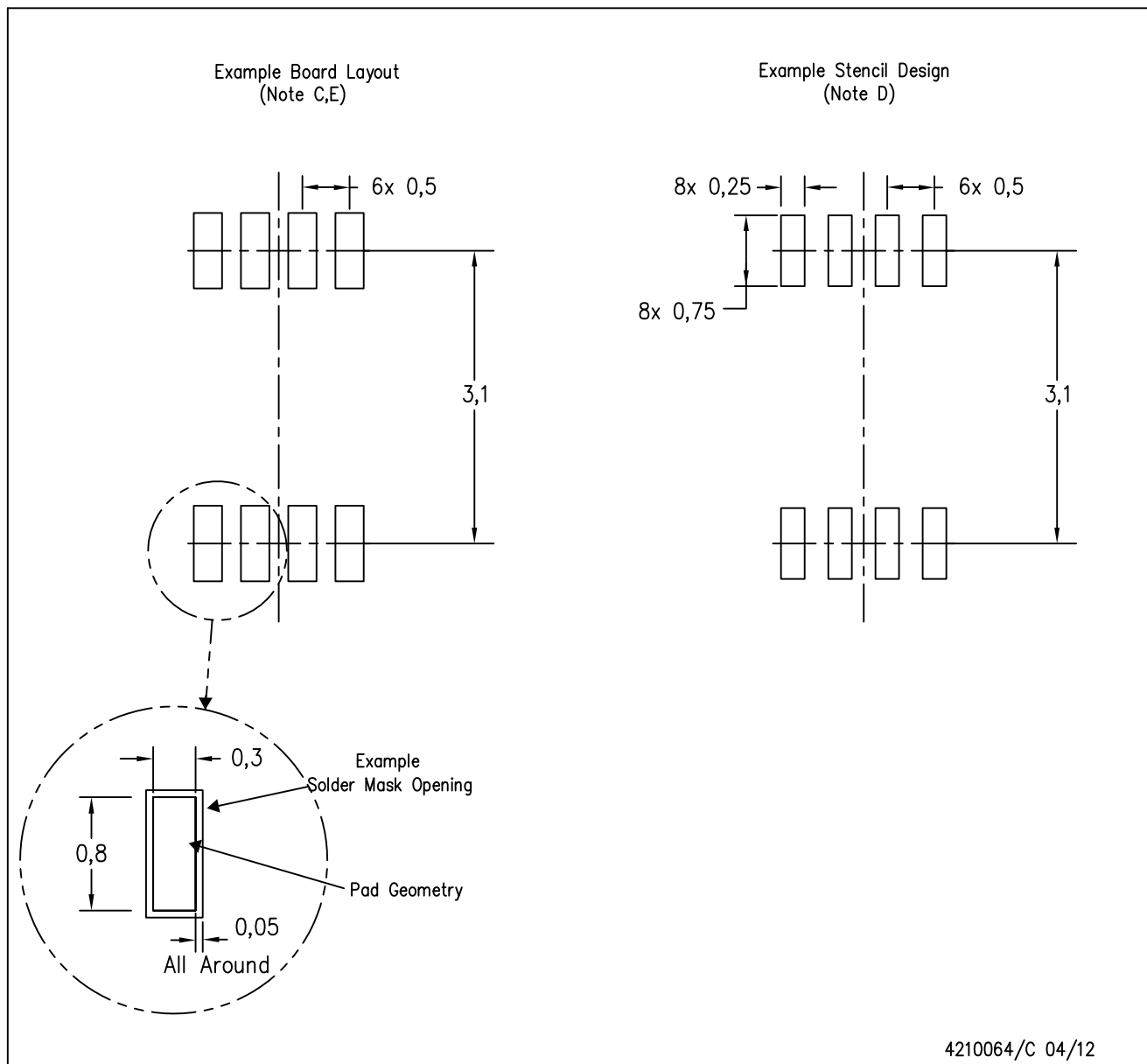

4210064/C 04/12

- NOTES:
- A. All linear dimensions are in millimeters.
 - B. This drawing is subject to change without notice.
 - C. Publication IPC-7351 is recommended for alternate designs.
 - D. Laser cutting apertures with trapezoidal walls and also rounding corners will offer better paste release. Customers should contact their board assembly site for stencil design recommendations. Refer to IPC-7525 for other stencil recommendations.
 - E. Customers should contact their board fabrication site for solder mask tolerances between and around signal pads.

IMPORTANT NOTICE

Texas Instruments Incorporated and its subsidiaries (TI) reserve the right to make corrections, enhancements, improvements and other changes to its semiconductor products and services per JESD46, latest issue, and to discontinue any product or service per JESD48, latest issue. Buyers should obtain the latest relevant information before placing orders and should verify that such information is current and complete. All semiconductor products (also referred to herein as "components") are sold subject to TI's terms and conditions of sale supplied at the time of order acknowledgment.

TI warrants performance of its components to the specifications applicable at the time of sale, in accordance with the warranty in TI's terms and conditions of sale of semiconductor products. Testing and other quality control techniques are used to the extent TI deems necessary to support this warranty. Except where mandated by applicable law, testing of all parameters of each component is not necessarily performed.

TI assumes no liability for applications assistance or the design of Buyers' products. Buyers are responsible for their products and applications using TI components. To minimize the risks associated with Buyers' products and applications, Buyers should provide adequate design and operating safeguards.

TI does not warrant or represent that any license, either express or implied, is granted under any patent right, copyright, mask work right, or other intellectual property right relating to any combination, machine, or process in which TI components or services are used. Information published by TI regarding third-party products or services does not constitute a license to use such products or services or a warranty or endorsement thereof. Use of such information may require a license from a third party under the patents or other intellectual property of the third party, or a license from TI under the patents or other intellectual property of TI.

Reproduction of significant portions of TI information in TI data books or data sheets is permissible only if reproduction is without alteration and is accompanied by all associated warranties, conditions, limitations, and notices. TI is not responsible or liable for such altered documentation. Information of third parties may be subject to additional restrictions.

Resale of TI components or services with statements different from or beyond the parameters stated by TI for that component or service voids all express and any implied warranties for the associated TI component or service and is an unfair and deceptive business practice. TI is not responsible or liable for any such statements.

Buyer acknowledges and agrees that it is solely responsible for compliance with all legal, regulatory and safety-related requirements concerning its products, and any use of TI components in its applications, notwithstanding any applications-related information or support that may be provided by TI. Buyer represents and agrees that it has all the necessary expertise to create and implement safeguards which anticipate dangerous consequences of failures, monitor failures and their consequences, lessen the likelihood of failures that might cause harm and take appropriate remedial actions. Buyer will fully indemnify TI and its representatives against any damages arising out of the use of any TI components in safety-critical applications.

In some cases, TI components may be promoted specifically to facilitate safety-related applications. With such components, TI's goal is to help enable customers to design and create their own end-product solutions that meet applicable functional safety standards and requirements. Nonetheless, such components are subject to these terms.

No TI components are authorized for use in FDA Class III (or similar life-critical medical equipment) unless authorized officers of the parties have executed a special agreement specifically governing such use.

Only those TI components which TI has specifically designated as military grade or "enhanced plastic" are designed and intended for use in military/aerospace applications or environments. Buyer acknowledges and agrees that any military or aerospace use of TI components which have **not** been so designated is solely at the Buyer's risk, and that Buyer is solely responsible for compliance with all legal and regulatory requirements in connection with such use.

TI has specifically designated certain components as meeting ISO/TS16949 requirements, mainly for automotive use. In any case of use of non-designated products, TI will not be responsible for any failure to meet ISO/TS16949.

Products

Audio	www.ti.com/audio
Amplifiers	amplifier.ti.com
Data Converters	dataconverter.ti.com
DLP® Products	www.dlp.com
DSP	dsp.ti.com
Clocks and Timers	www.ti.com/clocks
Interface	interface.ti.com
Logic	logic.ti.com
Power Mgmt	power.ti.com
Microcontrollers	microcontroller.ti.com
RFID	www.ti-rfid.com
OMAP Applications Processors	www.ti.com/omap
Wireless Connectivity	www.ti.com/wirelessconnectivity

Applications

Automotive and Transportation	www.ti.com/automotive
Communications and Telecom	www.ti.com/communications
Computers and Peripherals	www.ti.com/computers
Consumer Electronics	www.ti.com/consumer-apps
Energy and Lighting	www.ti.com/energy
Industrial	www.ti.com/industrial
Medical	www.ti.com/medical
Security	www.ti.com/security
Space, Avionics and Defense	www.ti.com/space-avionics-defense
Video and Imaging	www.ti.com/video

TI E2E Community

e2e.ti.com