

USB 2.0 High-Speed and Audio Switches with Negative Signal Capability

Features

- Single +2.7V to +4.4V Supply Voltage
- Low 50µA Supply Current
- -3dB Bandwidth: 1500MHz (typ)
- Low 2.5Ω(typ)On-Resistance
- THD+N: 0.02%
- Shorting D+/R and D-/L to Vbus will not cause leakage when $V_{DD} = 0$
- Internal Shunt Resistors for Click-and-Pop Reduction
- VBUS Detection for Automatic Switch Path Selection
- Packaging (Pb-free & Green available):
= 10-pin contact UQFN, 1.4 x 1.8, (ZM10)

Description

The PI3USB223 combines AC coupled audio signals and USB2.0 HS (480Mbps) on the same pins. This enables users to use a single connector to drive either a USB end point or an audio end point.

PI3USB223 incorporates gate pump technology required to maintain low Ron for ideal audio THD while reducing the capacitance affect of high speed USB signals. The device also incorporates a substrate pump technology which allows -2V signals to pass through the switch without causing any leakage.

The PI3USB223 features protection on D+/R and D-/L to ensure no damage will happen to the IC if these pins are shorted accidentally to Vbus as well as ensuring there is no leakage when V_{DD} is on or off. Also, it includes VBUS detection (VB) to automatically switch to the USB signal path upon detection of a valid VBUS signal. It also features internal shunt resistors on the audio path to reduce clicks and pops heard during output. The device is available in a space-saving 10-pin, 1.4mm x 1.8mm UQFN package, and operate over the -40°C to +85°C temperature range.

Block Diagram

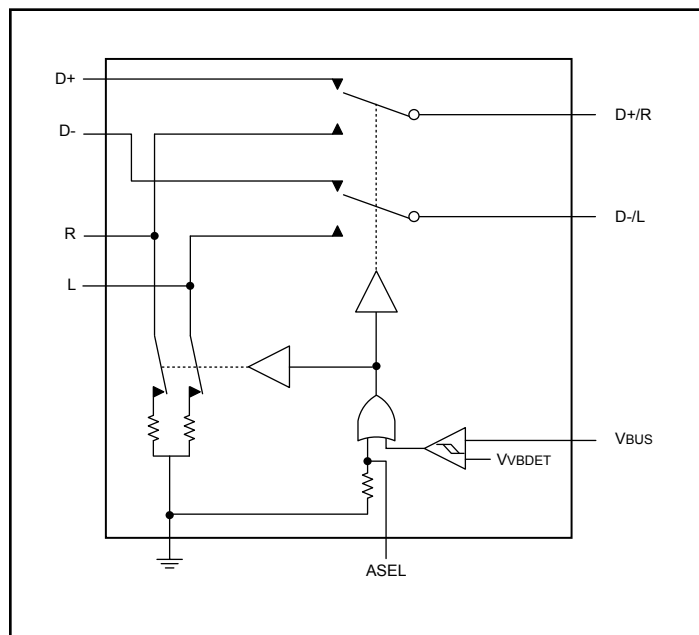

Pin Configuration

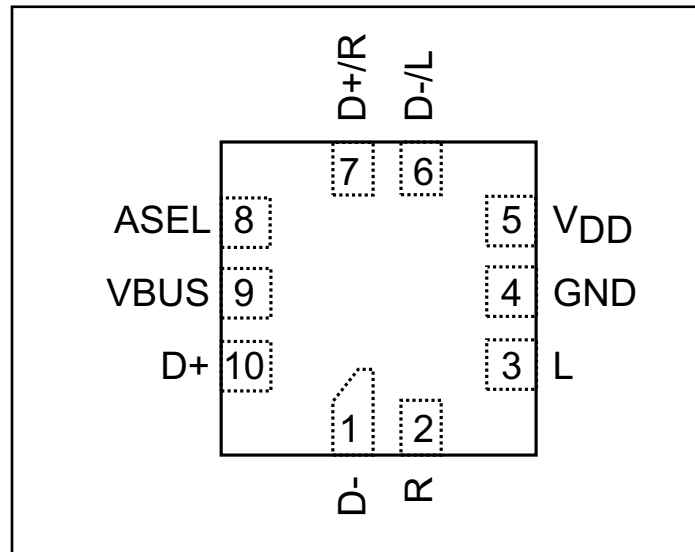

Truth Table

ASEL	V _{DD}	VBUS	L/R	D+/D-	L/R Shunt
X	L	L	OFF	OFF	OFF
X	H	L	OFF	OFF	ON
X	L	H	OFF	OFF	OFF
L	H	H	OFF	ON	ON
H	H	H	ON	OFF	OFF

Maximum Ratings

(Above which useful life may be impaired. For user guidelines, not tested.)

(Voltages referenced to GND.)	
V _{DD} , ASEL, VBUS.....	-0.3V to +5.0
V _(R/D+) and V _(L/D-) ⁽¹⁾	- 2.0V to +5.0
V _(R/D+) and V _(L/D-) ⁽²⁾	-0.3V to +5.0
V _R and V _L	-2.0V to (V _{DD} + 0.3V)
V _{D+} and V _{D-}	-0.3V to (V _{DD} + 0.3V)
Continuous Current into Any Terminal.....	±100mA
Continuous Power Dissipation (T _A = +70°C)10-Pin UQFN (derate 6.9mW/°C above +70°C).....	559mW
Junction-to-Case Thermal Resistance (θ _{JC}) ⁽²⁾	
10-Pin UQFN.....	20.1°C/W
Junction-to-Ambient Thermal Resistance (θ _{JA}) ⁽²⁾	
10-Pin UQFN.....	143.1°C/W
Operating Temperature Range.....	-40°C to +85°C
Junction Temperature Range.....	-40°C to +150°C
Storage Temperature Range.....	-65°C to +150°C
Lead Temperature (soldering, 10s).....	+300°C

Notes:

1. If Audio path is enabled
2. If USB path is enabled

Stresses greater than those listed under MAXIMUM RATINGS may cause permanent damage to the device. This is a stress rating only and functional operation of the device at these or any other conditions above those indicated in the operational sections of this specification is not implied. Exposure to absolute maximum rating conditions for extended periods may affect reliability.

Pin Description

Pin No.	Name	Function
1	D-	USB D- from system side
2	R	Audio Input (Right)
3	L	Audio Input (Left)
4	GND	Ground
5	V _{DD}	Positive Supply Voltage Input. Bypass V _{DD} to GND with a 0.1μF capacitor as close to the device as possible.
6	D-/L	Common Terminal for D- or Left Audio
7	D+/R	Common Terminal for D+ or Right Audio
8	ASEL	Switch SEL to override VBUS detection when VBUS and V _{DD} are both high. If ASEL is HIGH, then audio path will be on If ASEL is LOW then USB path will be on ASEL has an internal 3M-ohm pull-down
9	VBUS	If ASEL is tied LOW, then VBUS detection can be used for auto switching. If ASEL is LOW VBUS = HIGH means USB path is active
10	D+	USB D+ from system side

DC Electrical Characteristics

($V_{DD} = 2.7V$ to $4.4V$, $T_A = -40^{\circ}C$ to $+85^{\circ}C$, unless otherwise noted. Typical values are at $V_{DD} = 3.0V$ to $3.6V$, $T_A = 25^{\circ}C$)

Parameter	Symbol	Test Conditions		Min.	Typ.	Max.	Units
Operating Power-supply range	V_{DD}			2.7	-	4.4	V
Supply Current	I_{CC}	$V_{DD} = 3.3V$	$ASEL = V_{BUS} = 0V$	-	-	50	μA
Power-supply Rejection Ratio	PSRR		$f = 10kHz$, $V_{DD} = 3.0 \pm 0.3V$, $R_{D+/R} = 50\Omega$	-	60	-	dB
Analog Signal Range	$V_{D+/-}$			0		V_{DD}	V
	$V_{R/L}$			-2		V_{DD}	
R/L On-Resistance	$R_{ON(R/L)}$		$V_{DD} = 3.0V$, $V_{R/L} = -1.5V$, $+1.5V$, $I_{D+/R}$ and $D-/L = 10mA$		2	5	Ω
D+/D- On-Resistance	$R_{ON(D+/-)}$		$V_{DD} = 3.0V$, $V_{D+/-} = -0.4V$ to $0.6V$, $I_{D+/R}$ and $D-/L = 10mA$		3.5	6	
			$V_{DD} = 3.0V$, $V_{D+/R}$ and $D-/L = 0V$ to $3.0V$, $I_{D+/R}$ and $D-/L = 10mA$			12	
R/L On-Resistance Match between Channels	$\Delta R_{ON(R/L)}$		$V_{DD} = 3.0V$, $V_{R/L} = 0V$, $I_{D+/R}$ and $D-/L = 10mA$			0.2	
D+/- On-Resistance Match between Channels	$\Delta R_{ON(D+/D-)}$		$V_{DD} = 3.0V$, $V_{D+/-} = 0V$, $I_{D+/R}$ and $D-/L = 10mA$			0.2	
R/L On-Resistance Flatness	$R_{FLAT(R/L)}$		$V_{DD} = 3.0V$, $I_{D+/R}$ and $D-/L = 10mA$, $V_{R/L} = -1.5V$ to $+1.5V$		0.3	0.5	
D+/D- On-Resistance Flatness	$R_{FLAT(D+/-)}$		$V_{DD} = 3.0V$, $I_{D+/R}$ and $D-/L = 10mA$, $V_{D+/-} = -0.4V$ to $0.6V$		0.25	0.5	
Shunt Switch Resistance	R_{SH}		Voltage on R or L = V_{DD}		25		k Ω
D+/- Off-Leakage Current	$I_{D+/-}(OFF)$		$V_{DD} = 3.0V$, $V_{D+/-} = 5V$, $V_{D+/R}$ and $D-/L = -1.5V$, $+2.5V$	-1		1	μA
R/L Off-Leakage Current	$I_{R/L}(OFF)$		$V_{DD} = 3.0V$, $V_{R/L} = 0V$, $V_{D+/R}$ and $D-/L = 0V$, $+2.5V$	-1		1	
D+/R and D-/L Off-Leakage Current	$I_{D+/R}$ and $D-/L(OFF)$		$V_{DD} = 3.0V$, $V_{D+/R}$ and $D-/L = 3.6V$, $V_{D+/-} = V_{R/L} = 0V$			5	μA
			$V_{DD} = 3.3V$, $V_{D+/R}$ and $D-/L = 0V$, $V_{D+/-} = V_{R/L} = 0V$			5	
			$V_{DD} = 0V$, $V_{D+/R}$ or $D-/L = 5.0V$, $V_{D+/-} = V_{R/L} = 0V$			5	

continued

Parameter	Symbol	Test Conditions		Min.	Typ.	Max.	Units
D+/R and D-/L On-Leakage Current	I _{D+/R and D-/L(ON)}	USB Mode	V _{DD} = 3.0V, V _{R/L} = 0V, 2.5V, unconnected, V _{D+/R and D-/L} = 0V, 2.5V	-200		200	nA
		Audio Mode	V _{DD} = 3.0V, V _{D+/-} = 0V, 2.5V, unconnected, V _{D+/R and D-/L} = -1.5V, +2.5V	-200		200	
Turn-On Time	t _{ON}	R/L to D-/L or D+/R, V _{DD} = 3.0V, Fig. 2	V _{R/L} = 1.5V, Z _L = 50-ohm//35pF, ASEL = V _{DD} , V _{BUS} = 5.0V to 0V		12	60	
		D+/- to D-/L or D+/R, V _{DD} = 3.0V, Fig. 2	V _{R/L} = 1.5V, Z _L = 50-ohm//35pF, V _{BUS} = 5.0V, ASEL = 0V to V _{DD}		12	60	
Turn-Off Time	t _{OFF}	R/L to D-/L or D+/R, V _{DD} = 3.0V, Fig. 2	V _{R/L} = 1.5V, Z _L = 50-ohm//35pF, ASEL = V _{DD} , V _{BUS} = 5.0V to 0V		1.4	5	μs
		D+/- to D-/L or D+/R, V _{DD} = 3.0V, Fig. 2	V _{R/L} = 1.5V, Z _L = 50-ohm//35pF, V _{BUS} = 5.0V, ASEL = 0V to V _{DD}		0.7	5	
Break-Before-Make Time Delay	t _D	Z _L = 50Ω // 35pF			13.5		
Output Skew Same Switch	t _{SK(P)}	Figure 3			10		ps
Output Skew Between Switches	t _{SK(O)}	Figure 3			10		
R/L Off-Capacitance	C _{R/L(OFF)}	V _{D+/R and D-/L} = 0.5V _{PP} , DC Bias = 0V, f = 1MHz,			3		pF
D+/- Off-Capacitance	C _{D+/(OFF)}	V _{D+/R and D-/L} = 1.5V _{PP} , DC Bias = 0V, f = 240MHz,			2.5		
On-Capacitance	C _{D+/R and D-/L(ON)}	USB Path, F = 240MHz, DC bias = 0V			9		
		Audio path, f = 100kHz, DC bias = 0V			8		
AC PERFORMANCE							
R/L -3dB Bandwidth	BW _{R/L}	R _S = R _L = 50Ω, V _{R/L} = 0dBm, Figure 4			1100		MHz
D+/- -3dB Bandwidth	BW _{D+/-}	R _S = R _L = 50Ω, V _{D+/-} = 0dBm, Figure 4			1500		

continued

Parameter	Symbol	Test Conditions	Min.	Typ.	Max.	Units
Insertion Loss	$I_{N((USB\ Path)}$	Frequency = 240MHz		-0.5		dB
Off Isolation	I_{SO}	Figure 4, f = 240MHz		-35		
Crosstalk	X_{TALK}	f = 100kHz, $V_{COM} = 1V_{RMS}$, $R_S = R_L = 50\Omega$, Figure 4		-80		
Total Harmonic Distortion + Noise	THD + N (for audio path)	R/L to D+/R and D-/L, f = 20Hz to 20kHz, $V_{D+/R}$ and $D-/L = 0.5V_{PP}$, DC Bias = 0V, $R_L = 600\Omega$		0.02		%
LOGIC INPUT						
Input Logic High	V_{IH} for ASEL		1.6			V
Input Logic Low	V_{IL} for ASEL				0.4	
	V_{IH} for Vbus		3.5			
	V_{IL} for Vbus				0.4	
Input Leakage Current	I_{IN}	VASEL and VVbus = 0V or V_{DD}	-10		10	μA
ESD PROTECTION						
All Pins		Human Body Model		± 2		kV
D+/R, D-/L, and VBUS		Human Body Model		± 12		
D+/R, D-/L, and VBUS		Contact, IEC61000-4-2		± 8		

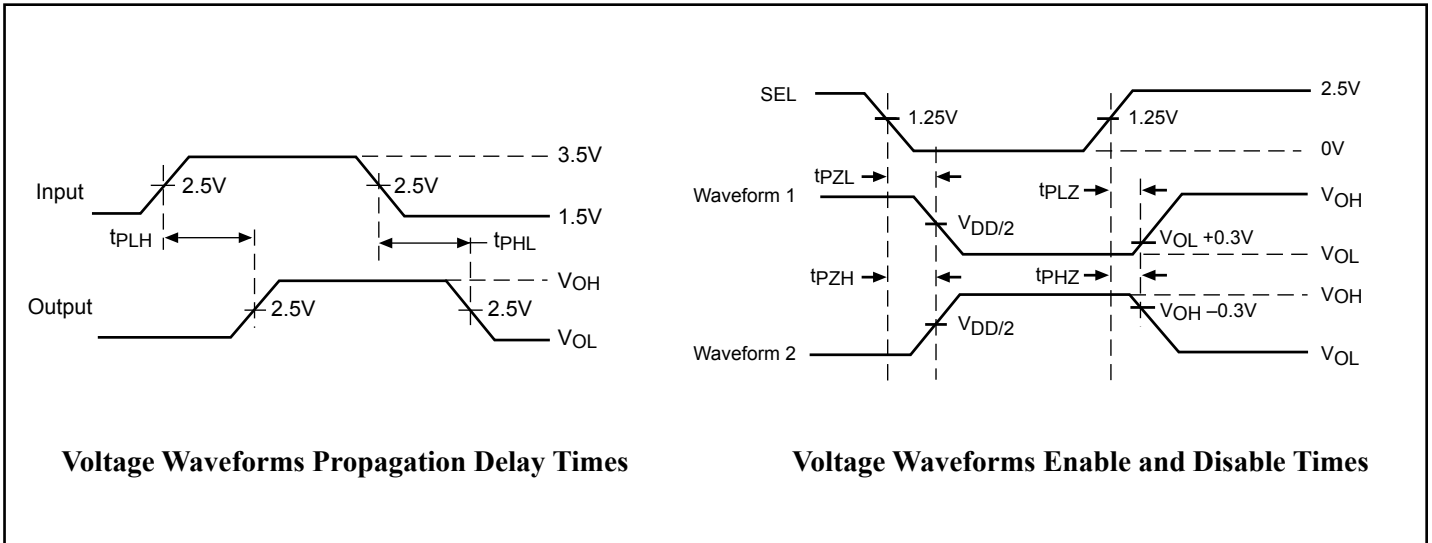
Switching Waveforms

Test Circuits and Timing Diagrams

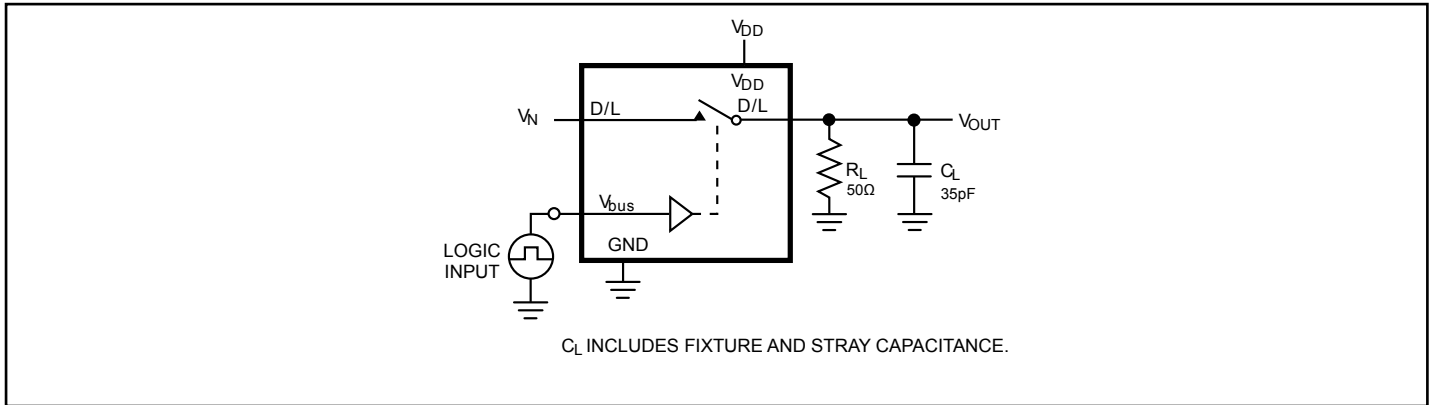

Note:

1. Unused input (NC or NO) must be grounded.

Figure 1. AC Test Circuit

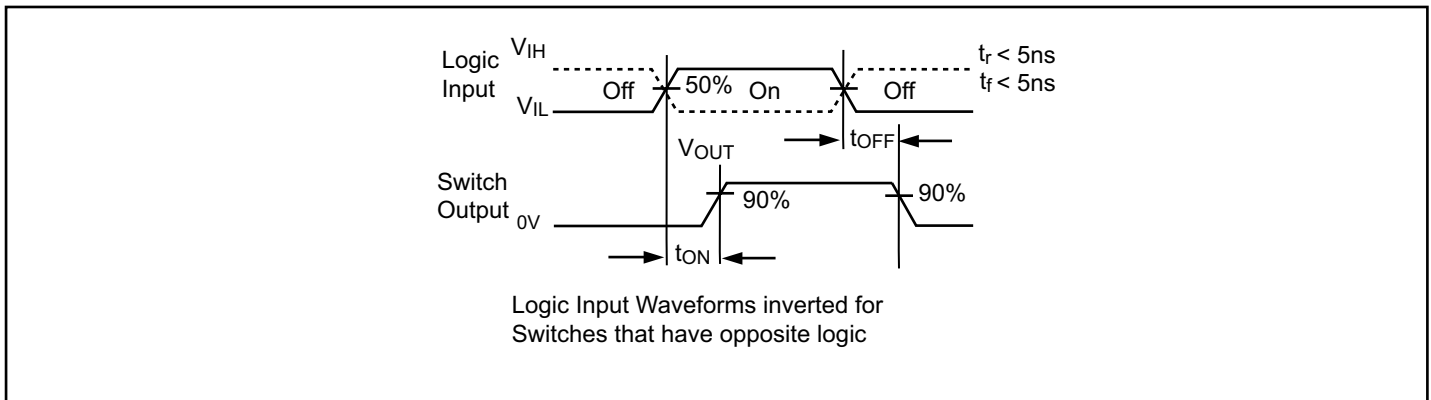

Figure 2. AC Waveforms

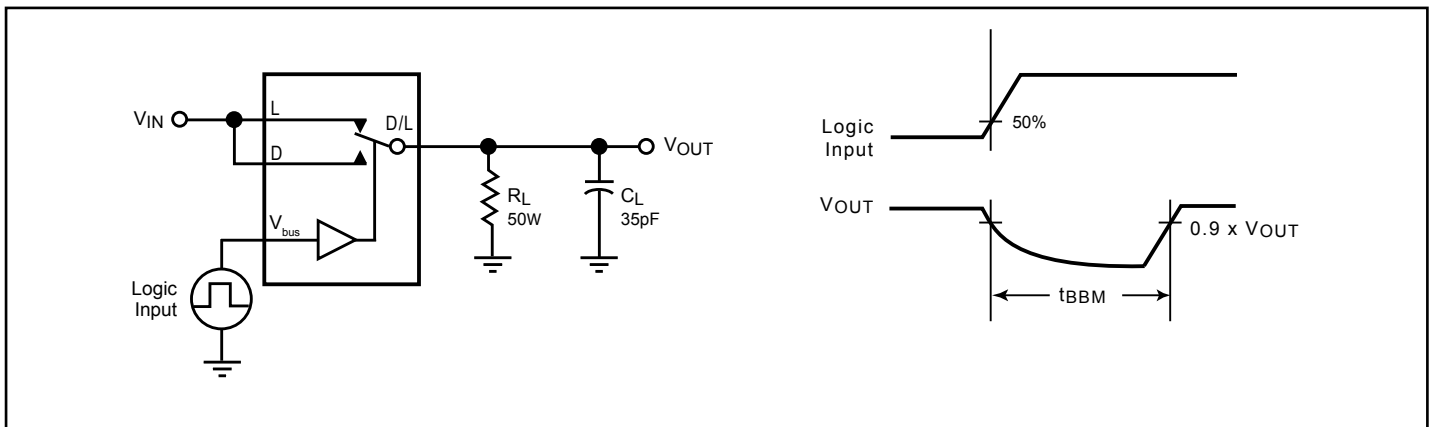

Figure 3. Break Before Make Interval Timing

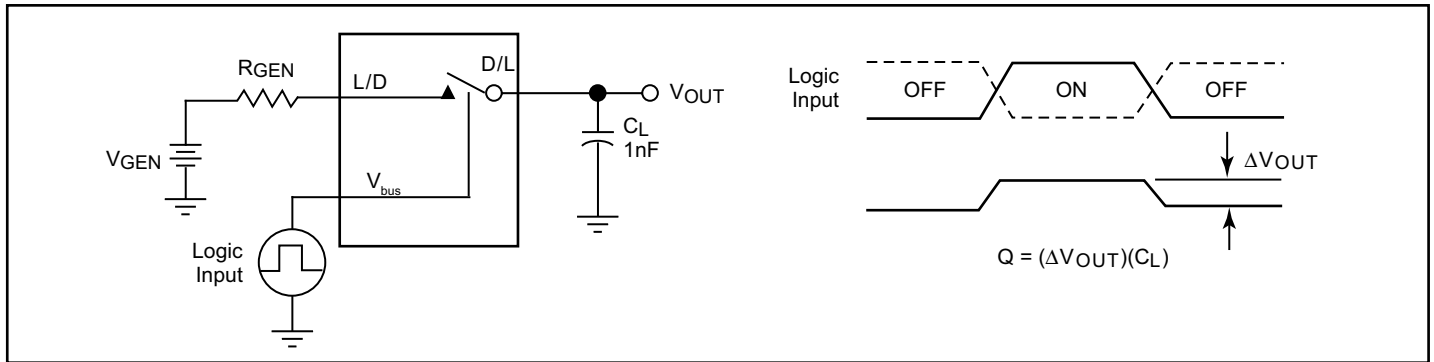

Figure 4. Charge Injection Test

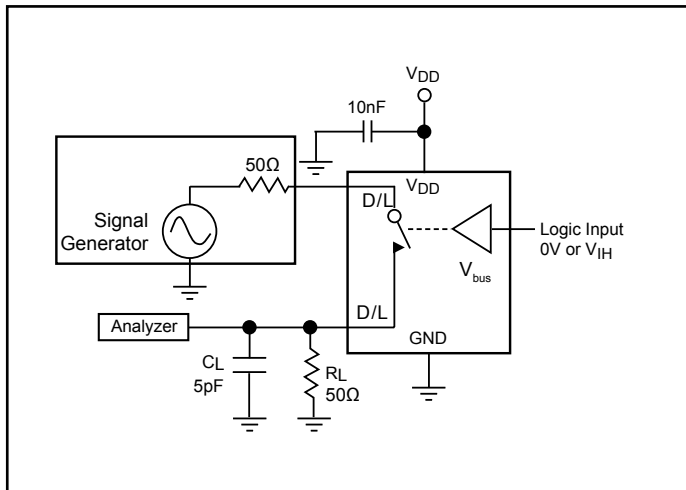

Figure 5. Off Isolation

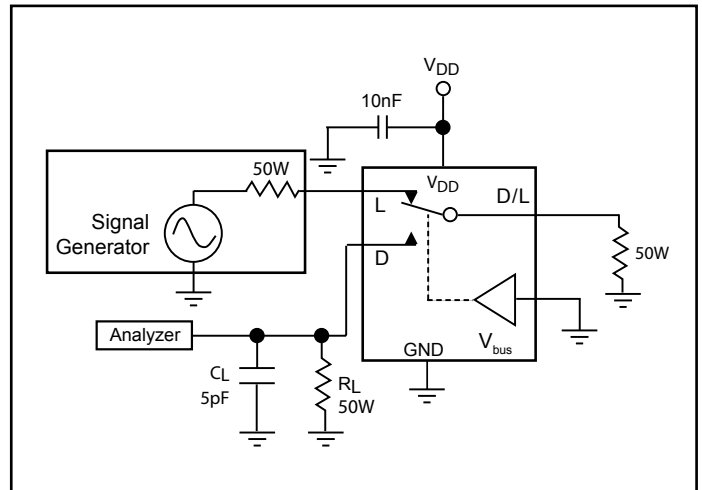

Figure 6. Crosstalk

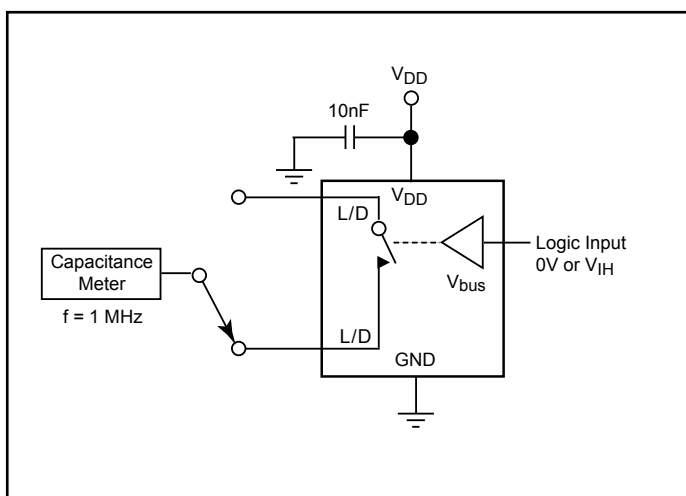

Figure 7. Channel Off Capacitance

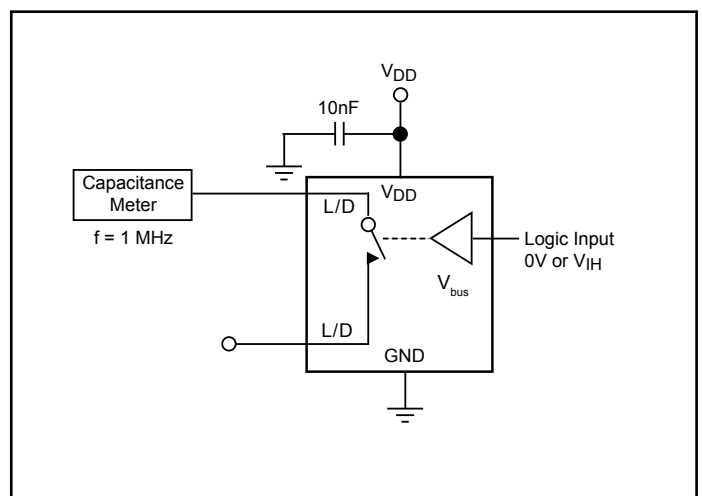

Figure 8. Channel On Capacitance

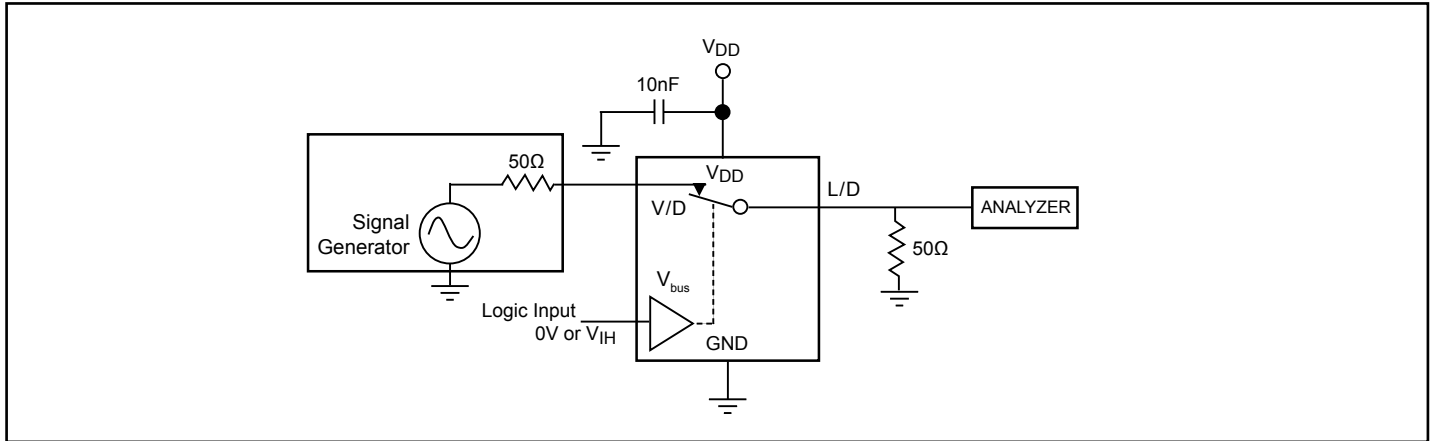
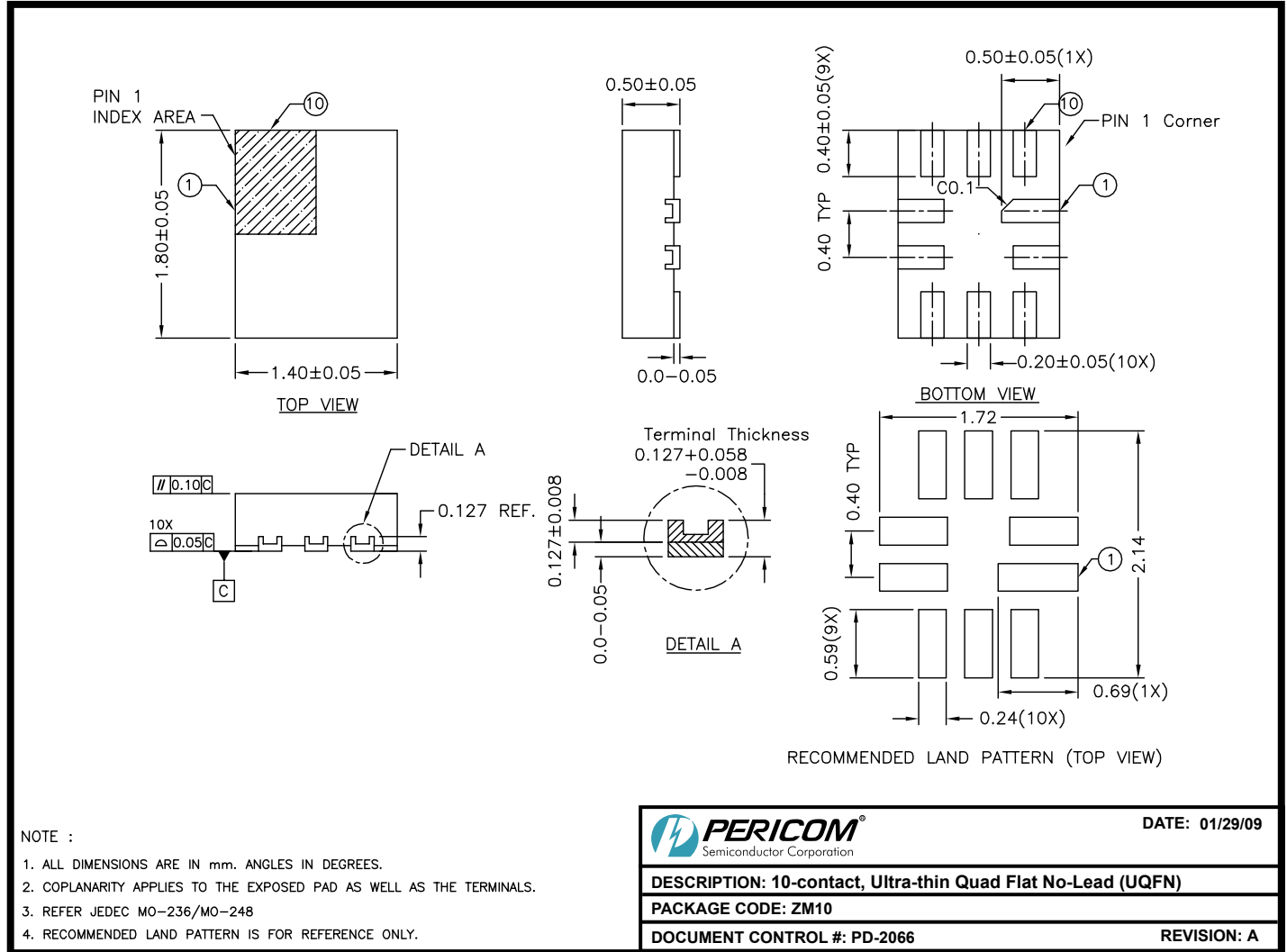

Figure 9. Bandwidth

Packaging Mechanical: 10-Contact UQFN (ZM)



09-0072

Note:

- For latest package info, please check: <http://www.pericom.com/products/packaging/mechanicals.php>

Ordering Information

Ordering Code	Package Code	Package Description	Top Mark
PI3USB223ZME	ZM	Pb-free & Green, 10-contact UQFN	RP

Notes:

- Thermal characteristics can be found on the company web site at www.pericom.com/packaging/
- E = Pb-free and Green
- X suffix = Tape/Reel