

## PIC18F66K80 Family Silicon Errata and Data Sheet Clarification

The PIC18F66K80 family devices that you have received conform functionally to the current Device Data Sheet (DS39977F), except for the anomalies described in this document.

The silicon issues discussed in the following pages are for silicon revisions with the Device and Revision IDs listed in [Table 1](#). The silicon issues are summarized in [Table 2](#).

The errata described in this document will be addressed in future revisions of the PIC18F66K80 silicon.

**Note:** This document summarizes all silicon errata issues from all revisions of silicon, previous as well as current. Only the issues indicated in the last column of [Table 2](#) apply to the current silicon revision (A6).

Data Sheet clarifications and corrections start on [page 9](#), following the discussion of silicon issues.

The silicon revision level can be identified using the current version of MPLAB® IDE and Microchip's programmers, debuggers and emulation tools, which are available at the Microchip corporate web site ([www.microchip.com](http://www.microchip.com)).

For example, to identify the silicon revision level using MPLAB IDE in conjunction with a hardware debugger:

1. Using the appropriate interface, connect the device to the hardware debugger.
2. Open an MPLAB IDE project.
3. Configure the MPLAB IDE project for the appropriate device and hardware debugger.
4. Based on the version of MPLAB IDE you are using, do one of the following:
  - a) For MPLAB IDE 8, select *Programmer > Reconnect*.
  - b) For MPLAB X IDE, select *Window > Dashboard* and click the Refresh Debug Tool Status icon (  ).
5. Depending on the development tool used, the part number and Device Revision ID value appear in the Output window.

**Note:** If you are unable to extract the silicon revision level, please contact your local Microchip sales office for assistance.

The DEVREV values for the various PIC18F66K80 silicon revisions are shown in [Table 1](#).

**TABLE 1: SILICON DEVREV VALUES**

Part Number	Device ID <sup>(1)</sup>	Revision ID for Silicon Revision <sup>(2)</sup>			
		A2	A3	A4	A6
PIC18F66K80	60E0	2h	3h	4h	6h
PIC18F65K80	6140				
PIC18F46K80	6100				
PIC18F45K80	6160				
PIC18F26K80	6120				
PIC18F25K80	6180				
PIC18LF66K80	61C0				
PIC18LF65K80	6220				
PIC18LF46K80	61E0				
PIC18LF45K80	6240				
PIC18LF26K80	6200				
PIC18LF25K80	6260				

**Note 1:** The Device IDs (DEVID and DEVREV) are located at the last two implemented addresses of Configuration memory space. They are shown in hexadecimal in the format, "DEVID DEVREV".

**2:** Refer to the "PIC18FXXK80 Family Flash Microcontroller Programming Specification" (DS39972) for detailed information on Device and Revision IDs for your specific device.

# PIC18F66K80

**TABLE 2: SILICON ISSUE SUMMARY**

Module	Feature	Item Number	Issue Summary	Affected Revisions <sup>(1)</sup>			
				A2	A3	A4	A6
Analog-to-Digital Converter (A/D)	A/D Performance	1.	The 12-bit A/D performance is outside the data sheet's A/D Converter specifications.	X	X	X	X
EUSART	Synchronous Transmit	2.	When using the Synchronous Transmit mode, transmitted data may become corrupted if using the TXxIF bit to determine when to load the TXREGx register.	X			
ECCP	Auto-Shutdown	3.	The tri-state setting of the auto-shutdown feature in the enhanced PWM will not successfully drive the pin to tri-state.	X	X	X	X
ECAN	CAN Clock Source Selection	4.	The CLKSEL bit in the CIOCON register is modifiable while the ECAN module is active.	X			
Ultra Low-Power Sleep	Sleep Entry	5.	Entering Ultra Low-Power Sleep mode by setting RETEN = 0 and SRETEN = 1, will cause the part to not be programmable through ICSP™.	X			
IPD and IDD	Maximum Limit	6.	Maximum current limits may be higher than specified in Table 31-2 of the data sheet.	X			
Reset (BOR)	Enable/Disable	7.	An unexpected Reset may occur if the Brown-out Reset module (BOR) is disabled and then re-enabled, when the High/Low-Voltage Detection module (HLVD) is not enabled (HLVDCON<4> = 0).	X	X	X	X
ECAN	EWIN	8.	The enhanced window address feature, EWIN<4:0>, in the ECANCON register, will not move the BnCON 0≤n≤5 registers into the access window of RAM.	X			
MCLRE	Master Clear Enable	9.	The Master Clear pin will not be readable when MCLRE is set to off for all 28-pin part variants (PIC18F2XK80).	X	X	X	X
Timer1/Timer3	Gated Enable	10.	Timer1 and Timer3 gate control will not function up to the speed of FOSC when the TxCON is set to the system clock (TxCON<7:6> = 01).	X	X		
Timer1/Timer3	Interrupt	11.	When the timer is operated in Asynchronous External Input mode, unexpected interrupt flag generation may occur.	X	X	X	X
Primary Oscillator	XT Mode	12.	XT Primary Oscillator mode does not reliably function when the driving crystals are above 3 MHz.	X	X	X	

**Note 1:** Only those issues indicated in the last column apply to the current silicon revision.

## Silicon Errata Issues

**Note:** This document summarizes all silicon errata issues from all revisions of silicon, previous as well as current. Only the issues indicated by the shaded column in the following tables apply to the current silicon revision (A6).

The 12-bit A/D issues will be fixed in future revisions of this part. Reduced bit resolution specifications can be derived by dividing, as appropriate. For instance, 10-bit guidance is obtained by dividing the parameters in Table 3 by four.

### A/D Offset

The A/D may have high offset error, up to a maximum of  $\pm 25$  LSBs; it can be used if the A/D is calibrated for the offset.

### Work around

Calibrate for offset in Single-Ended mode by connecting A/D +ve input to ground and taking the A/D reading. This will be the offset of the device and can be used to compensate for the subsequent A/D readings on the actual inputs.

### 1. Module: Analog-to-Digital Converter (A/D)

The 12-bit A/D performance is outside the data sheet's A/D Converter specifications. When used as a 12-bit A/D, the possible issues are: high offset error, up to a maximum of  $\pm 25$  LSBs at 25°C,  $\pm 30$  LSBs at 85°C, 125°C and -40°C; high DNL error, up to a maximum of +6.0/-4.0 LSBs; and multiple missing codes, up to a maximum of twenty. Users should evaluate the 12-bit A/D performance in their application using the suggested work around below. See Table 3 for guidance specifications.

**TABLE 3: A/D CONVERTER CHARACTERISTICS**

Param No.	Sym.	Characteristic	Min.	Typ.	Max.	Units	Conditions
A01	NR	Resolution	—	—	12	bit	$\Delta V_{REF} \geq 5.0V$
A03	EIL	Integral Linearity Error	—	—	$\pm 10.0$	LSb	$\Delta V_{REF} \geq 5.0V$
A04	EDL	Differential Linearity Error	—	—	+6.0/-4.0	LSb	$\Delta V_{REF} \geq 5.0V$
A06	E <sub>OFF</sub>	Offset Error	—	—	$\pm 25$ $\pm 30$	LSb	$\Delta V_{REF} \geq 5.0V$ , TEMP = 25°C TEMP $\geq 85^\circ C$ , -40°C
A07	E <sub>GN</sub>	Gain Error	—	—	$\pm 15$	LSb	$\Delta V_{REF} \geq 5.0V$
A10	—	Monotonicity <sup>(1)</sup>	—				$V_{SS} \leq V_{AIN} \leq V_{REF}$
A20	$\Delta V_{REF}$	Reference Voltage Range (V <sub>REFH</sub> – V <sub>REFL</sub> )	3	—	$AV_{DD} - AV_{SS}$	V	
A21	V <sub>REFH</sub>	Reference Voltage High	$AV_{SS} + 3.0V$	—	$AV_{DD} + 0.3V$	V	
A22	V <sub>REFL</sub>	Reference Voltage Low	$AV_{SS} - 0.3V$	—	$AV_{DD} - 3.0V$	V	
A25	V <sub>AIN</sub>	Analog Input Voltage	V <sub>REFL</sub>	—	V <sub>REFH</sub>	V	

**Note 1:** The A/D conversion result never decreases with an increase in the input voltage.

### Affected Silicon Revisions

A2	A3	A4	A6				
X	X	X	X				

# PIC18F66K80

## 2. Module: EUSART

In Synchronous Transmit mode, data may be corrupted if using the TXxIF bit to determine when to load the TXREGx register. One or more of the intended transmit messages may be incorrect.

### Work around

A fixed delay added before loading TXREGx may not be a reliable work around. When loading the TXREGx, check that the TRMT bit inside of the TXSTAx register is set instead of checking the TXxIF bit. The following code can be used:

```
while(!TXSTAxbits.TRMT);  
// wait to load TXREGx until TRMT is set
```

### Affected Silicon Revisions

A2	A3	A4	A6				
X							

## 3. Module: ECCP

The tri-state setting of the auto-shutdown feature, in the enhanced PWM will not successfully drive the pin to tri-state. The pin will remain an output and should not be driven externally. All tri-state settings will be affected.

### Work around

Use one of the other two auto-shutdown states available, as outlined in the data sheet.

### Affected Silicon Revisions

A2	A3	A4	A6				
X	X	X	X				

## 4. Module: ECAN

The CLKSEL bit in the CIOCON register remains modifiable while the ECAN module is not in Configuration mode. Accidental state changes of this bit will result in immediate bit clock changes that will affect all nodes on the bus.

### Work around

While the ECAN module is in Run mode, do not modify the state of the CLKSEL bit in the CIOCON register unless the CAN module is first changed into Configuration mode.

### Affected Silicon Revisions

A2	A3	A4	A6				
X							

## 5. Module: Ultra Low-Power Sleep

Entering Ultra Low-Power Sleep mode by setting RETEN = 0 and SRETEN = 1 will cause the part to not be programmable through ICSP™. This issue occurs when the RETEN fuse bit in CONFIG1L<0> is cleared to '0', the SRETEN bit in the WDTCON register is set to '1' and a SLEEP instruction is executed within the first 350 μs of code execution. This happens after a Reset event, causing the part to enter Ultra Low-Power Sleep mode.

### Work around

Use Normal Sleep and Low-Power Sleep modes only, or on any Reset, ensure that at least 350 μs pass before executing a SLEEP instruction when ULP is enabled. To ensure the Ultra Low-Power Sleep mode is not enabled, the RETEN fuse bit in CONFIG1L<0> should be set to a '1' and the SRETEN bit in the WDTCON register should be cleared to a '0'. The following code can be used:

```
//This will ensure the RETEN fuse is set to 1  
#pragma config RETEN = OFF  
//This will ensure the SRETEN bit is 0  
WDTCONbits.SRETEN = 0;
```

If the Ultra Low-Power Sleep mode is needed, then the user must ensure that the minimum time, before the first SLEEP instruction is executed, is greater than 350 μs.

### Affected Silicon Revisions

A2	A3	A4	A6				
X							

## 6. Module: IPD and IDD

The IPD and IDD limits do not match the data sheet. The IPD values, shown in **bold** in [Section 31.2 “DC Characteristics: Power-Down and Supply Current PIC18F66K80 Family \(Industrial/Extended\)”](#) (below), reflect the updated silicon maximum limits.

All IDD maximum limits will equal 2.8 times the value listed in the data sheet.

### Affected Silicon Revisions

A2	A3	A4	A6				
X							

## 31.2 DC Characteristics: Power-Down and Supply Current PIC18F66K80 Family (Industrial/Extended)

PIC18F66K80 (Industrial/Extended)		Standard Operating Conditions (unless otherwise stated) Operating temperature -40°C ≤ TA ≤ +85°C for industrial -40°C ≤ TA ≤ +125°C for extended				
Param No.	Device	Typ.	Max.	Units	Conditions	
Power-Down Current (IPD) <sup>(1)</sup>						
PIC18LFXXK80		0.008	<b>7</b>	μA	-40°C	VDD = 1.8V <sup>(4)</sup> (Sleep mode) Regulator Disabled
		0.013	<b>7</b>	μA	+25°C	
		0.035	<b>9</b>	μA	+60°C	
		0.218	<b>10</b>	μA	+85°C	
		3	<b>12</b>	μA	±125°C	
PIC18LFXXK80		0.014	<b>8</b>	μA	-40°C	VDD = 3.3V <sup>(4)</sup> (Sleep mode) Regulator Disabled
		0.034	<b>8</b>	μA	+25°C	
		0.092	<b>9</b>	μA	+60°C	
		0.312	<b>10</b>	μA	+85°C	
		4	<b>16</b>	μA	±125°C	
PIC18FXXXK80		0.2	<b>9</b>	μA	-40°C	VDD = 3.3V (Sleep mode) Regulator Enabled
		0.23	<b>9</b>	μA	+25°C	
		0.32	<b>10</b>	μA	+60°C	
		0.51	<b>11</b>	μA	+85°C	
		5	<b>18</b>	μA	±125°C	
PIC18FXXXK80		0.22	<b>10</b>	μA	-40°C	VDD = 5V <sup>(5)</sup> (Sleep mode) Regulator Enabled
		0.24	<b>10</b>	μA	+25°C	
		0.34	<b>11</b>	μA	+60°C	
		0.54	<b>12</b>	μA	+85°C	
		5	<b>20</b>	μA	±125°C	

Legend: Shading of rows is to assist in readability of the table.

- Note 1: The power-down current in Sleep mode does not depend on the oscillator type. Power-down current is measured with the part in Sleep mode, with all I/O pins in high-impedance state and tied to VDD or VSS, and all features that add delta current disabled (such as WDT, SOSC oscillator, BOR, etc.).
- 2: The supply current is mainly a function of operating voltage, frequency and mode. Other factors, such as I/O pin loading and switching rate, oscillator type and circuit, internal code execution pattern and temperature, also have an impact on the current consumption.  
The test conditions for all IDD measurements in active operation mode are:  
OSC1 = external square wave, from rail-to-rail; all I/O pins tri-stated, pulled to VDD;  
MCLR = VDD; WDT enabled/disabled as specified.
- 3: Standard, low-cost 32 kHz crystals have an operating temperature range of -10°C to +70°C. Extended temperature crystals are available at a much higher cost.
- 4: For LF devices, RETEN (CONFIG1L<0>) = 1.
- 5: For F devices, SRETEN (WDTCON<4>) = 1 and RETEN (CONFIG1L<0>) = 0.

# PIC18F66K80

## 7. Module: Reset (BOR)

An unexpected Reset may occur if the Brown-out Reset module (BOR) is disabled, and then re-enabled, when the High/Low-Voltage Detection module (HLVD) is not enabled (HLVDCON<4> = 0). This issue affects BOR modes: BOREN<1:0> = 10 and BOREN<1:0> = 01. In both of these modes, if the BOR module is re-enabled while the device is active, unexpected Resets may be generated.

### Work around

If BOR is required and power consumption is not an issue, use BOREN<1:0> = 11. For BOREN<1:0> = 10 mode, either switch to BOREN<1:0> = 11 mode or enable the HLVD (HLVDCON<4> = 1) prior to entering Sleep. If power consumption is an issue and low power is desired, do not use BOREN<1:0> = 10 mode. Instead, use BOREN<1:0> = 01 and follow the steps below when entering and exiting Sleep.

1. Disable BOR by clearing SBOREN (RCON<6> = 0).  

```
WDTCONbits.SBOREN = 0;
```
2. Enter Sleep mode (if desired).  

```
Sleep();
```
3. After exiting Sleep mode (if entered), enable the HLVD bit (HLVDCON<4> = 1).  

```
HLVDCONbits.HLV DEN = 1;
```
4. Wait for the internal reference voltage (TIRVST) to stabilize (typically 25 μs).  

```
while(!HLVDCONbits.IRVST);
```
5. Re-enable BOR by setting SBOREN (RCON<6> = 1).  

```
WDTCONbits.SBOREN = 1;
```
6. Disable the HLVD by clearing HLVDEN (HLVDCON<4> = 0).  

```
HLVDCONbits.HLV DEN = 0;
```

### Affected Silicon Revisions

A2	A3	A4	A6				
X	X	X	X				

## 8. Module: ECAN

The enhanced window address feature, EWIN<4:0>, in the ECANCON register, will not move the BnCON 0≤n≤5 registers into the access window of RAM. The rest of the registers in B0 through B5 will be transferred into the access bank successfully. This feature is only available in Mode 1 and Mode 2; Mode 0 applications will not be affected.

### Work around

1. Set the ECANCON register EWIN bits to the desired buffer.  

```
ECANCONbits.EWIN = Buffer_Selection;
```
2. Decode the desired buffer to each individual Buffer Control register, BnCON 0≤n≤5.

```
switch (Buffer_Selection)
{
//EWIN code for Buffer B0
case 18:
    break;

//EWIN code for Buffer B5
case 23:
    break;
default:
    break;
}
```

3. Process information in the selected buffer control register. Note that the BnCON 0≤n≤5 Control registers can be set up for either transmit or receive operations.  

```
case 18:
    //Save B0CON and clear flags
    being processed
    temp = B0CON;
    //clear any flags
    break;
```
4. Continue processing the rest of the buffer in the windowed location.

### Affected Silicon Revisions

A2	A3	A4	A6				
X							

## 9. Module: MCLRE

The Master Clear pin will not be readable when MCLRE is set to off for all 28-pin part variants (PIC18F2XK80). When the MCLRE bit, CONFIG3H<7>, is cleared on the 28-pin devices, the MCLR pin will be disabled but input data will not be available on RE3.

### Work around

None.

### Affected Silicon Revisions

A2	A3	A4	A6				
X	X	X	X				

## 10. Module: Timer1/Timer3

Timer1 and Timer3 gate control will not function up to the speed of FOSC when the TxCON is set to the system clock (TxCON<7:6> = 01). Results will always be at the resolution of FOSC/4, although the internal FOSC has been selected as the clock source.

### Work around

Use the external clock input pin setting, TxCON<7:6> = 10 and TxCON<3> = 0.

### Affected Silicon Revisions

A2	A3	A4	A6				
X	X						

## 11. Module: Timer1/Timer3

When Timer1 or Timer3 is operated in Asynchronous External Input mode, unexpected interrupt flag generation may occur if an external clock edge arrives too soon following a firmware write to the TMRxH:TMRxL registers. An unexpected interrupt flag event may also occur when enabling the module or switching from Synchronous to Asynchronous mode.

### Work around

This issue only applies when operating the timer in Asynchronous mode. Whenever possible, operate the Timer module in Synchronous mode to avoid spurious timer interrupts.

If Asynchronous mode must be used in the application, potential strategies to mitigate the issue may include any of the following:

- Design the firmware so it does not rely on the TMRxIF flag or keep the respective interrupt disabled. The timer still counts normally and does not reset to 0x0000 when the spurious interrupt flag event is generated.
- Design the firmware so that it does not write to the TMRxH:TMRxL registers or does not periodically disable/enable the timer, or switch modes. Reading from the timer does not trigger the spurious interrupt flag events.
- If the firmware must use the timer interrupts and must write to the timer (or disable/enable, or mode switch the timer), implement code to suppress the spurious interrupt event, should it occur. This can be achieved by following the process shown in [Example 1](#).

# PIC18F66K80

## EXAMPLE 1: ASYNCHRONOUS TIMER MODE WORK AROUND TO AVOID SPURIOUS INTERRUPT

```
//Timer1 update procedure in asynchronous mode
//The code below uses Timer1 as example

T1CONbits.TMR1ON = 0;           //Stop timer from incrementing
PIE1bits.TMR1IE = 0;           //Temporarily disable Timer1 interrupt vectoring
TMR1H = 0x00;                   //Update timer value
TMR1L = 0x00;
T1CONbits.TMR1ON = 1;           //Turn on timer

//Now wait at least two full T1CKI periods + 2TCY before re-enabling Timer1 interrupts.
//Depending upon clock edge timing relative to TMR1H/TMR1L firmware write operation,
//a spurious TMR1IF flag event may sometimes assert. If this happens, to suppress
//the actual interrupt vectoring, the TMR1IE bit should be kept clear until
//after the "window of opportunity" (for the spurious interrupt flag event has passed).
//After the window is passed, no further spurious interrupts occur, at least
//until the next timer write (or mode switch/enable event).

while(TMR1L < 0x02);           //Wait for 2 timer increments more than the Updated Timer
//value (indicating more than 2 full T1CKI clock periods elapsed)
NOP();                           //Wait two more instruction cycles
NOP();
PIR1bits.TMR1IF = 0;           //Clear TMR1IF flag, in case it was spuriously set
PIE1bits.TMR1IE = 1;           //Now re-enable interrupt vectoring for timer 1
```

### Affected Silicon Revisions

A2	A3	A4	A6				
X	X	X	X				

## 12. Module: Primary Oscillator (XT Mode)

On some parts, using the XT oscillator at the top end of its specified frequency range (3.0-4.0 MHz) may cause the part to cease driving the oscillator.

### Work around

Use the XT mode only for frequencies lower than 3.0 MHz.

Use the HS mode if frequencies greater than 4.0 MHz on a crystal oscillator are required.

### Affected Silicon Revisions

A2	A3	A4	A6				
X	X	X					

## Data Sheet Clarifications

The following typographic corrections and clarifications are to be noted for the latest version of the device data sheet (DS39977F):

**Note:** Corrections are shown in **bold**. Where possible, the original bold text formatting has been removed for clarity.

### 1. Module: A/D Converter Characteristics

The values in [Table 31-25](#) reflect the updated A/D Converter Characteristics. The new information is shown in **bold** text.

**TABLE 31-25: A/D CONVERTER CHARACTERISTICS: PIC18F66K80 FAMILY (INDUSTRIAL/EXTENDED)**

Param No.	Sym.	Characteristic	Min.	Typ.	Max.	Units	Conditions
A01	NR	Resolution	—	—	12	bit	$\Delta V_{REF} \geq 5.0V$
A03	EIL	Integral Linearity Error	—	$<\pm 1$	$\pm 6.0$	LSB	$\Delta V_{REF} \geq 5.0V$
A04	EDL	Differential Linearity Error	—	$<\pm 1$	+3.0/-1.0	LSB	$\Delta V_{REF} \geq 5.0V$
A06	E <sub>OFF</sub>	Offset Error	—	$<\pm 1$	$\pm 9.0$	LSB	$\Delta V_{REF} \geq 5.0V$
A07	E <sub>GN</sub>	Gain Error	—	$<\pm 1$	$\pm 8.0$	LSB	$\Delta V_{REF} \geq 5.0V$
A10	—	Monotonicity <sup>(1)</sup>	—			—	$V_{SS} \leq V_{AIN} \leq V_{REF}$
A20	$\Delta V_{REF}$	Reference Voltage Range (V <sub>REFH</sub> – V <sub>REFL</sub> )	3	—	V <sub>DD</sub> – V <sub>SS</sub>	V	For 12-bit resolution
A21	V <sub>REFH</sub>	Reference Voltage High	V <sub>SS</sub> + 3.0V	—	V <sub>DD</sub> + 0.3V	V	For 12-bit resolution
A22	V <sub>REFL</sub>	Reference Voltage Low	V <sub>SS</sub> – 0.3V	—	V <sub>DD</sub> – 3.0V	V	For 12-bit resolution
A25	V <sub>AIN</sub>	Analog Input Voltage	V <sub>REFL</sub>	—	V <sub>REFH</sub>	V	
A28	V <sub>DD</sub>	Analog Supply Voltage	V <sub>DD</sub> – 0.3	—	V <sub>DD</sub> + 0.3	V	
A29	V <sub>SS</sub>	Analog Supply Voltage	V <sub>SS</sub> – 0.3	—	V <sub>SS</sub> + 0.3	V	
A30	Z <sub>AIN</sub>	Recommended Impedance of Analog Voltage Source	—	—	2.5	k $\Omega$	
A50	I <sub>REF</sub>	V <sub>REF</sub> Input Current <sup>(2)</sup>	—	—	5	$\mu A$	During V <sub>AIN</sub> acquisition.
			—	—	150	$\mu A$	During A/D conversion cycle.

**Note 1:** The A/D conversion result never decreases with an increase in the input voltage.

**Note 2:** V<sub>REFH</sub> current is from the RA3/AN3/V<sub>REF+</sub> pin or V<sub>DD</sub>, whichever is selected as the V<sub>REFH</sub> source. V<sub>REFL</sub> current is from the RA2/AN2/V<sub>REF-</sub>/CV<sub>REF</sub> pin or V<sub>SS</sub>, whichever is selected as the V<sub>REFL</sub> source.

### 2. Module: Electrical Characteristics

Parameter **D041** in **Section 31.3 “DC Characteristics: PIC18F66K80 Family (Industrial)”** on page 555 of the data sheet lists its minimum value as 0.8. This should be 0.8 V<sub>DD</sub>.

### 3. Module: A/D Converter

Bits 5-4 of Register 23-2: AD<sub>CON1</sub> (VCFG<1:0>) should have the following note attached:

**Note 1:** When CHS<4:0> = 11111, a VCFG<1:0> value of 10 or 11 is not allowed.

# PIC18F66K80

---

## 4. Module: I/O Ports

### 4.1 Open-Drain Outputs Description

Page 173 **Section 11.1.3 'Open-Drain Outputs'** will be revised to:

The output pins for several peripherals are also equipped with a configurable, open-drain output option. **This allows the peripherals to communicate with external pull-up voltage.**

The open-drain option is implemented on port pins specifically associated with the data and clock outputs of the USARTs, the MSSP module (in SPI mode) and the CCP modules. This option is selectively enabled by setting the open-drain control bits in the ODCON register.

**When the open-drain option is required, the output pin must also be tied through an external pull-up resistor provided by the user.**

### 4.2 Open-Drain Outputs Diagram

[Figure 11-2: Using the Open-Drain Output \(Usart Shown as Example\)](#) on page 173 should be as follows:

**FIGURE 11-2: USING THE OPEN-DRAIN OUTPUT (USARTx SHOWN AS EXAMPLE)**

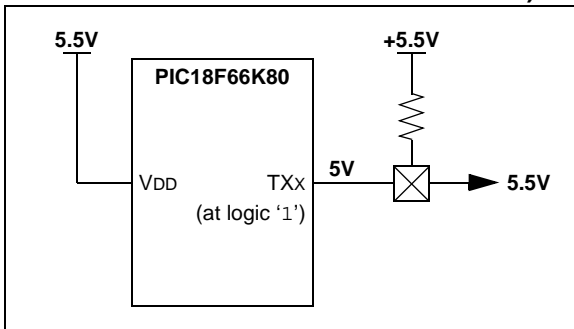

## 5. Module: A/D Converter

Bits 2-0 of [Register 23-2](#) ADCON1  
(CHSN<2:0>) should be as follows:

### REGISTER 23-2: ADCON1: A/D CONTROL REGISTER 1

R/W-0	R/W-0	R/W-0	R/W-0	R/W-x	R/W-x	R/W-x	R/W-x
TRIGSEL1	TRIGSEL0	VCFG1	VCFG0	VNCFG	CHSN2	CHSN1	CHSN0
bit 7							bit 0

#### Legend:

R = Readable bit	W = Writable bit	U = Unimplemented bit, read as '0'
-n = Value at POR	'1' = Bit is set	'0' = Bit is cleared
		x = Bit is unknown

- bit 7-6      **TRIGSEL<1:0>**: Special Trigger Select bits  
 11 = Selects the special trigger from the CCP2  
 10 = Selects the special trigger from the Timer1  
 01 = Selects the special trigger from the CTMU  
 00 = Selects the special trigger from the ECCP1
- bit 5-4      **VCFG<1:0>**: A/D VREF+ Configuration bits  
 11 = Internal VREF+ (4.1V)  
 10 = Internal VREF+ (2.0V)  
 01 = External VREF+  
 00 = AVDD
- bit 3        **VNCFG**: A/D VREF- Configuration bit  
 1 = External VREF  
 0 = AVSS
- bit 2-0      **CHSN<2:0>**: Analog Negative Channel Select bits  
 111 = **Reserved**  
 110 = Channel 06 (AN5)  
 101 = Channel 05 (AN4)  
 100 = Channel 04 (AN3)  
 011 = Channel 03 (AN2)  
 010 = Channel 02 (AN1)  
 001 = Channel 01 (AN0)  
 000 = Channel 00 (AVSS)

# PIC18F66K80

## 6. Module: A/D Converter

The AD $SGN<3:0>$  bits in [Register 23-5](#) and the AD $SGN<7:4>$  bits in [Register 23-6](#) are improperly labeled as Unimplemented. The correct registers are below:

### REGISTER 23-5: ADRESL: A/D RESULT LOW BYTE REGISTER, LEFT JUSTIFIED (ADFM = 0)

R/W-x	R/W-x	R/W-x	R/W-x	R/W-x	R/W-x	R/W-x	R/W-x
ADRES3	ADRES2	ADRES1	ADRES0	ADSGN3	ADSGN2	ADSGN1	ADSGN0
bit 7							

#### Legend:

R = Readable bit                      W = Writable bit                      U = Unimplemented bit, read as '0'  
-n = Value at POR                      '1' = Bit is set                      '0' = Bit is cleared                      x = Bit is unknown

bit 7-4                      **ADRES<3:0>**: A/D Result Low Byte bits

bit 3-0                      **ADSGN<3:0>**: A/D Result Sign bits

1 = A/D result is negative

0 = A/D result is positive

### REGISTER 23-6: ADRESH: A/D RESULT HIGH BYTE REGISTER, RIGHT JUSTIFIED (ADFM = 1)

R/W-x	R/W-x	R/W-x	R/W-x	R/W-x	R/W-x	R/W-x	R/W-x
ADSGN7	ADSGN6	ADSGN5	ADSGN4	ADRES11	ADRES10	ADRES9	ADRES8
bit 7							

#### Legend:

R = Readable bit                      W = Writable bit                      U = Unimplemented bit, read as '0'  
-n = Value at POR                      '1' = Bit is set                      '0' = Bit is cleared                      x = Bit is unknown

bit 7-4                      **ADSGN<7:4>**: A/D Result Sign bits

1 = A/D result is negative

0 = A/D result is positive

bit 3-0                      **ADRES<11:8>**: A/D Result High Byte bits

## 7. Module: ECCP Compare Mode

The following text should be added to the Compare Mode section of the data sheet.

### 19.3.5 COMPARE MODE INTERRUPT TIMING

For all Compare modes, an interrupt may be triggered when the selected TIMER register pair matches the value in the CCPRx register pair. This interrupt will be triggered upon the timer transitioning from the value of the CCPRx register pair to the next value.

## 8. Module: Product Identification System

The Product Identification System is missing a few package type codes. The correct list is as follows:

<u>PART NO.</u>	<u>X</u>	<u>/XX</u>	<u>XXX</u>
Device	Temperature Range	Package	Pattern
Device <sup>(1,2)</sup>	PIC18F65K80, PIC18F46K80, PIC18F45K80, PIC18F26K80, PIC18F25K80, PIC18LF66K80 VDD range 1.8V to 5V		
	PIC18LF25K80, PIC18LF26K80, PIC18LF45K80, PIC18LF46K80, PIC18F25K80, PIC18LF66K80 VDD range 1.8V to 3.6V		
Temperature Range	I = -40°C to +85°C (Industrial) E = -40°C to +125°C (Extended)		
Package	P = PDIP Plastic Dual In-Line MR = 64-Pin QFN Plastic Quad Flat, No Lead Package ML = 44-Pin QFN Plastic Quad Flat, No Lead Package MM = 28-Pin QFN Plastic Quad Flat, No Lead Package SO = SOIC Plastic Small Outline SP = SPDIP Skinny Plastic Dual In-Line SS = SSOP Plastic Shrink Small Outline PT = TQFP Plastic Thin Quad Flatpack		
Pattern	a) QTP, SQTP, Code or Special Requirements (blank otherwise)		

### Examples:

- PIC18LF66K80-I/MR 301 = Industrial temp., QFN package, Extended VDD limits, QTP pattern #301.
- PIC18LF66K80-I/PT = Industrial temp., TQFP package, Extended VDD limits.

- Note 1:** F = Standard Voltage Range  
LF = Low Voltage Range
- 2:** T = in tape and reel, TQFP packages only.

# PIC18F66K80

---

## APPENDIX A: DOCUMENT REVISION HISTORY

### Rev A Document (2/2011)

Initial release of this document; issued for revision, A2. Includes silicon issues 1 (Analog-to-Digital Converter), 2 (EUSART), 3 (ECCP), 4 (ECAN), 5 (Ultra Low-Power Sleep) and 6 (IPD and IDD).

### Rev B Document (4/2011)

Added silicon issues 7 (Reset – BOR) and 8 (ECAN). Added data sheet clarifications 1, 2 (RXFCON Registers) and 3 (Listen Only Mode).

### Rev C Document (9/2011)

Added [Table 3](#), 10-Bit A/D Converter Characteristics to silicon issue 1 (Analog-to-Digital Converter). Added silicon issues 9 (MCLRE) and 10 (Timer1/Timer3). Added data sheet clarifications 4 (A/D Converter Characteristics) and 5 (HLVD).

### Rev D Document (12/2011)

Added silicon revision A4; includes issues 1 (Analog-to-Digital Converter – A/D), 3 (ECCP), 7 (Reset – BOR) issues 9 (MCLRE). Added data sheet clarification 6 (Power-up Timer Period).

Updated data sheet revision level to “D”. All previous clarifications carried into this revision.

### Rev E Document (12/2013)

Added MPLAB X IDE; Updated silicon issue 1 (Analog-to-Digital Converter); Added silicon issue 11 (Primary Oscillator); Other minor corrections;

Data Sheet Clarifications: Added Module 7 (Electrical Characteristics) and Module 8 (A/D Converter).

### Rev F Document (2/2014)

Added Silicon Revision A6; Data Sheet Clarification: Added Module 9 and 10; Other minor corrections.

### Rev G Document (4/2014)

Data Sheet Clarifications: Added Module 11; Other minor corrections.

### Rev H Document (7/2014)

Added Module 11, Timer1/Timer3 to Silicon errata Issues section.

### Rev J Document (7/2015)

Data Sheet Clarifications:

Removed the following modules, data sheet has been updated: Module 1: RXFCON Registers; Module 2: RXFCON Registers; Module 3: Listen Only Mode; Module 5: HLVD; Module 6: Power-up Timer Period. Renumbered remaining modules.

Added Module 7; Added Module 8; Other minor corrections.

---

**Note the following details of the code protection feature on Microchip devices:**

- Microchip products meet the specification contained in their particular Microchip Data Sheet.
- Microchip believes that its family of products is one of the most secure families of its kind on the market today, when used in the intended manner and under normal conditions.
- There are dishonest and possibly illegal methods used to breach the code protection feature. All of these methods, to our knowledge, require using the Microchip products in a manner outside the operating specifications contained in Microchip's Data Sheets. Most likely, the person doing so is engaged in theft of intellectual property.
- Microchip is willing to work with the customer who is concerned about the integrity of their code.
- Neither Microchip nor any other semiconductor manufacturer can guarantee the security of their code. Code protection does not mean that we are guaranteeing the product as “unbreakable.”

Code protection is constantly evolving. We at Microchip are committed to continuously improving the code protection features of our products. Attempts to break Microchip's code protection feature may be a violation of the Digital Millennium Copyright Act. If such acts allow unauthorized access to your software or other copyrighted work, you may have a right to sue for relief under that Act.

---

Information contained in this publication regarding device applications and the like is provided only for your convenience and may be superseded by updates. It is your responsibility to ensure that your application meets with your specifications. MICROCHIP MAKES NO REPRESENTATIONS OR WARRANTIES OF ANY KIND WHETHER EXPRESS OR IMPLIED, WRITTEN OR ORAL, STATUTORY OR OTHERWISE, RELATED TO THE INFORMATION, INCLUDING BUT NOT LIMITED TO ITS CONDITION, QUALITY, PERFORMANCE, MERCHANTABILITY OR FITNESS FOR PURPOSE. Microchip disclaims all liability arising from this information and its use. Use of Microchip devices in life support and/or safety applications is entirely at the buyer's risk, and the buyer agrees to defend, indemnify and hold harmless Microchip from any and all damages, claims, suits, or expenses resulting from such use. No licenses are conveyed, implicitly or otherwise, under any Microchip intellectual property rights unless otherwise stated.

#### **Trademarks**

The Microchip name and logo, the Microchip logo, dsPIC, FlashFlex, flexPWR, JukeBlox, KEELOQ, KEELOQ logo, Klear, LANCheck, MediaLB, MOST, MOST logo, MPLAB, OptoLyzer, PIC, PICSTART, PIC<sup>32</sup> logo, RightTouch, SpyNIC, SST, SST Logo, SuperFlash and UNI/O are registered trademarks of Microchip Technology Incorporated in the U.S.A. and other countries.

The Embedded Control Solutions Company and mTouch are registered trademarks of Microchip Technology Incorporated in the U.S.A.

Analog-for-the-Digital Age, BodyCom, chipKIT, chipKIT logo, CodeGuard, dsPICDEM, dsPICDEM.net, ECAN, In-Circuit Serial Programming, ICSP, Inter-Chip Connectivity, KlearNet, KlearNet logo, MiWi, MPASM, MPF, MPLAB Certified logo, MPLIB, MPLINK, MultiTRAK, NetDetach, Omniscient Code Generation, PICDEM, PICDEM.net, PICkit, PICtail, RightTouch logo, REAL ICE, SQI, Serial Quad I/O, Total Endurance, TSHARC, USBCheck, VariSense, ViewSpan, WiperLock, Wireless DNA, and ZENA are trademarks of Microchip Technology Incorporated in the U.S.A. and other countries.

SQTP is a service mark of Microchip Technology Incorporated in the U.S.A.

Silicon Storage Technology is a registered trademark of Microchip Technology Inc. in other countries.

GestIC is a registered trademark of Microchip Technology Germany II GmbH & Co. KG, a subsidiary of Microchip Technology Inc., in other countries.

All other trademarks mentioned herein are property of their respective companies.

© 2011-2015, Microchip Technology Incorporated, Printed in the U.S.A., All Rights Reserved.

ISBN: 978-1-63277-595-5

**QUALITY MANAGEMENT SYSTEM**  
**CERTIFIED BY DNV**  
**== ISO/TS 16949 ==**

*Microchip received ISO/TS-16949:2009 certification for its worldwide headquarters, design and wafer fabrication facilities in Chandler and Tempe, Arizona; Gresham, Oregon and design centers in California and India. The Company's quality system processes and procedures are for its PIC® MCUs and dsPIC® DSCs, KEELOQ® code hopping devices, Serial EEPROMs, microperipherals, nonvolatile memory and analog products. In addition, Microchip's quality system for the design and manufacture of development systems is ISO 9001:2000 certified.*



# MICROCHIP

## Worldwide Sales and Service

### AMERICAS

#### Corporate Office

2355 West Chandler Blvd.  
Chandler, AZ 85224-6199  
Tel: 480-792-7200  
Fax: 480-792-7277  
Technical Support:  
[http://www.microchip.com/  
support](http://www.microchip.com/support)

Web Address:  
[www.microchip.com](http://www.microchip.com)

#### Atlanta

Duluth, GA  
Tel: 678-957-9614  
Fax: 678-957-1455

#### Austin, TX

Tel: 512-257-3370

#### Boston

Westborough, MA  
Tel: 774-760-0087  
Fax: 774-760-0088

#### Chicago

Itasca, IL  
Tel: 630-285-0071  
Fax: 630-285-0075

#### Cleveland

Independence, OH  
Tel: 216-447-0464  
Fax: 216-447-0643

#### Dallas

Addison, TX  
Tel: 972-818-7423  
Fax: 972-818-2924

#### Detroit

Novi, MI  
Tel: 248-848-4000

#### Houston, TX

Tel: 281-894-5983

#### Indianapolis

Noblesville, IN  
Tel: 317-773-8323  
Fax: 317-773-5453

#### Los Angeles

Mission Viejo, CA  
Tel: 949-462-9523  
Fax: 949-462-9608

#### New York, NY

Tel: 631-435-6000

#### San Jose, CA

Tel: 408-735-9110

#### Canada - Toronto

Tel: 905-673-0699  
Fax: 905-673-6509

### ASIA/PACIFIC

#### Asia Pacific Office

Suites 3707-14, 37th Floor  
Tower 6, The Gateway  
Harbour City, Kowloon

#### Hong Kong

Tel: 852-2943-5100  
Fax: 852-2401-3431

#### Australia - Sydney

Tel: 61-2-9868-6733  
Fax: 61-2-9868-6755

#### China - Beijing

Tel: 86-10-8569-7000  
Fax: 86-10-8528-2104

#### China - Chengdu

Tel: 86-28-8665-5511  
Fax: 86-28-8665-7889

#### China - Chongqing

Tel: 86-23-8980-9588  
Fax: 86-23-8980-9500

#### China - Dongguan

Tel: 86-769-8702-9880

#### China - Hangzhou

Tel: 86-571-8792-8115  
Fax: 86-571-8792-8116

#### China - Hong Kong SAR

Tel: 852-2943-5100  
Fax: 852-2401-3431

#### China - Nanjing

Tel: 86-25-8473-2460  
Fax: 86-25-8473-2470

#### China - Qingdao

Tel: 86-532-8502-7355  
Fax: 86-532-8502-7205

#### China - Shanghai

Tel: 86-21-5407-5533  
Fax: 86-21-5407-5066

#### China - Shenyang

Tel: 86-24-2334-2829  
Fax: 86-24-2334-2393

#### China - Shenzhen

Tel: 86-755-8864-2200  
Fax: 86-755-8203-1760

#### China - Wuhan

Tel: 86-27-5980-5300  
Fax: 86-27-5980-5118

#### China - Xian

Tel: 86-29-8833-7252  
Fax: 86-29-8833-7256

### ASIA/PACIFIC

#### China - Xiamen

Tel: 86-592-2388138  
Fax: 86-592-2388130

#### China - Zhuhai

Tel: 86-756-3210040  
Fax: 86-756-3210049

#### India - Bangalore

Tel: 91-80-3090-4444  
Fax: 91-80-3090-4123

#### India - New Delhi

Tel: 91-11-4160-8631  
Fax: 91-11-4160-8632

#### India - Pune

Tel: 91-20-3019-1500

#### Japan - Osaka

Tel: 81-6-6152-7160  
Fax: 81-6-6152-9310

#### Japan - Tokyo

Tel: 81-3-6880-3770  
Fax: 81-3-6880-3771

#### Korea - Daegu

Tel: 82-53-744-4301  
Fax: 82-53-744-4302

#### Korea - Seoul

Tel: 82-2-554-7200  
Fax: 82-2-558-5932 or  
82-2-558-5934

#### Malaysia - Kuala Lumpur

Tel: 60-3-6201-9857  
Fax: 60-3-6201-9859

#### Malaysia - Penang

Tel: 60-4-227-8870  
Fax: 60-4-227-4068

#### Philippines - Manila

Tel: 63-2-634-9065  
Fax: 63-2-634-9069

#### Singapore

Tel: 65-6334-8870  
Fax: 65-6334-8850

#### Taiwan - Hsin Chu

Tel: 886-3-5778-366  
Fax: 886-3-5770-955

#### Taiwan - Kaohsiung

Tel: 886-7-213-7828

#### Taiwan - Taipei

Tel: 886-2-2508-8600  
Fax: 886-2-2508-0102

#### Thailand - Bangkok

Tel: 66-2-694-1351  
Fax: 66-2-694-1350

### EUROPE

#### Austria - Wels

Tel: 43-7242-2244-39  
Fax: 43-7242-2244-393

#### Denmark - Copenhagen

Tel: 45-4450-2828  
Fax: 45-4485-2829

#### France - Paris

Tel: 33-1-69-53-63-20  
Fax: 33-1-69-30-90-79

#### Germany - Dusseldorf

Tel: 49-2129-3766400

#### Germany - Karlsruhe

Tel: 49-721-625370

#### Germany - Munich

Tel: 49-89-627-144-0  
Fax: 49-89-627-144-44

#### Italy - Milan

Tel: 39-0331-742611  
Fax: 39-0331-466781

#### Italy - Venice

Tel: 39-049-7625286

#### Netherlands - Drunen

Tel: 31-416-690399  
Fax: 31-416-690340

#### Poland - Warsaw

Tel: 48-22-3325737

#### Spain - Madrid

Tel: 34-91-708-08-90  
Fax: 34-91-708-08-91

#### Sweden - Stockholm

Tel: 46-8-5090-4654

#### UK - Wokingham

Tel: 44-118-921-5800  
Fax: 44-118-921-5820

07/14/15