



**MODEL:** PJ-009B | **DESCRIPTION:** DC POWER JACK

**FEATURES**

- 2.5 mm center pin
- 2.5 A rating
- vertical orientation
- through hole



**SPECIFICATIONS**

| parameter                       | conditions/description   | min | typ   | max      | units    |
|---------------------------------|--|-----|-------|----------|----------|
| rated input voltage             |  |     | 16    |          | Vdc      |
| rated input current             |  |     |       | 2.5      | A        |
| contact resistance <sup>1</sup> | between terminal and mating plug<br>between terminal in a closed circuit |     |       | 50<br>30 | mΩ<br>mΩ |
| insulation resistance           | at 500 Vdc   | 100 |       |          | MΩ       |
| voltage withstand               | at 50/60Hz for 1 minute  |     |       | 500      | Vac      |
| insertion/withdrawal force      |  | 0.3 |       | 3        | kg       |
| terminal strength               | any direction for 10 seconds   |     |       | 500      | g        |
| operating temperature           |  | -25 |       | 85       | °C       |
| life                            |  |     | 5,000 |          | cycles   |
| flammability rating             | UL94V-0  |     |       |          |          |
| RoHS                            | 2011/65/EU   |     |       |          |          |

Note: 1. When measured at a current of less than 100 mA/1 kHz

**SOLDERABILITY**

| parameter      | conditions/description                  | min | typ | max | units |
|----------------|---|-----|-----|-----|-------|
| wave soldering | dipped in solder pot for 5 ±0.5 seconds | 255 | 260 | 265 | °C    |

## MECHANICAL DRAWING

units: mm[inches]  
 tolerance:  
 X.X ±0.2mm  
 X.XX ±0.1mm  
 X.XXX ±0.05mm

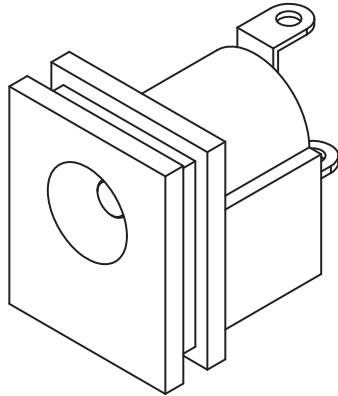

|            | MATERIAL     | PLATING |
|------------|--------------|---------|
| center pin | copper       | nickel  |
| terminal 1 | brass        | tin     |
| terminal 2 | copper alloy | tin     |
| terminal 3 | brass        | tin     |
| plastic    | PBT          |         |

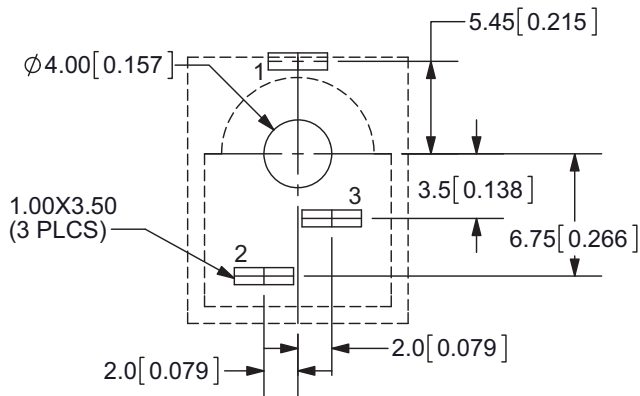
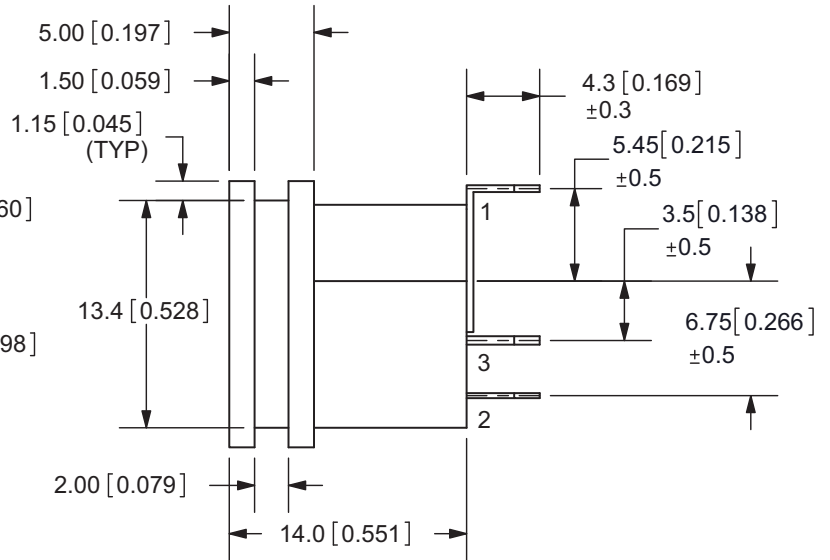
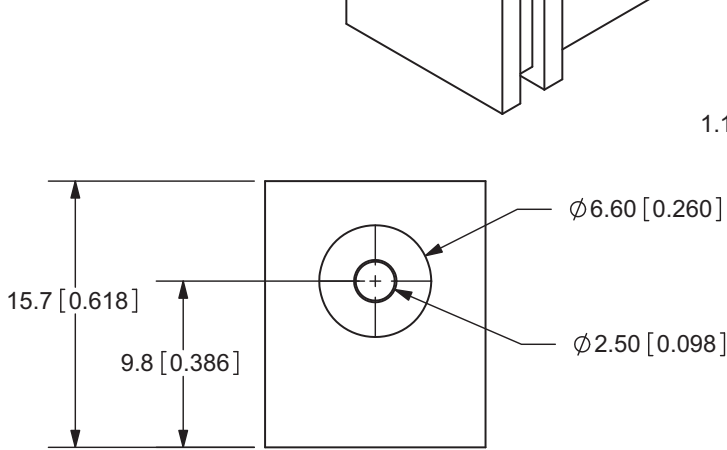

PCB LAYOUT  
FRONT VIEW

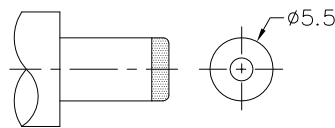
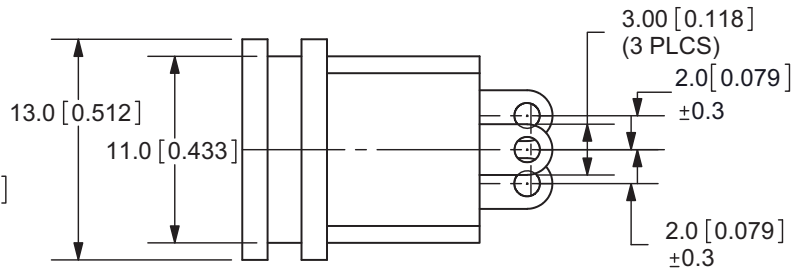

MATING PLUG  
Jack Insertion Depth: 9.5 mm

|            |         |
|------------|---------|
| SCHEMATIC  |         |
| Model      | PJ-009B |
| Center Pin | Ø2.5 mm |

Note: 1. All specifications measured at 10~35°C, humidity at 45~85%, under standard atmospheric pressure, unless otherwise noted.

## REVISION HISTORY

---

| <b>rev.</b> | <b>description</b>                        | <b>date</b> |
|-------------|---|-------------|
| 1.0         | initial release                           | 11/08/2005  |
| 1.01        | updated center pin and terminal locations | 08/11/2011  |
| 1.02        | applied new spec template                 | 11/04/2013  |

The revision history provided is for informational purposes only and is believed to be accurate.



**Headquarters**  
20050 SW 112th Ave.  
Tualatin, OR 97062  
**800.275.4899**

Fax 503.612.2383  
**cui.com**  
techsupport@cui.com

CUI offers a one (1) year limited warranty. Complete warranty information is listed on our website.

CUI reserves the right to make changes to the product at any time without notice. Information provided by CUI is believed to be accurate and reliable. However, no responsibility is assumed by CUI for its use, nor for any infringements of patents or other rights of third parties which may result from its use.

CUI products are not authorized or warranted for use as critical components in equipment that requires an extremely high level of reliability. A critical component is any component of a life support device or system whose failure to perform can be reasonably expected to cause the failure of the life support device or system, or to affect its safety or effectiveness.