

PTC Thermistors, Mini Radial Leaded for Over-Temperature Protection



Non preferred type
(replaced by PTCSL03)

FEATURES

- Well-defined protection temperature levels
- Fast reaction time (< 15 s in still air)
- Accurate resistance for ease of circuit design
- Excellent long term behavior (< 1 °C or 5 % after 1000 h at $T_n + 15$ °C)
- Wide range of protection temperatures (70 °C to 150 °C)
- Small size and rugged
- Material categorization: for definitions of compliance please see www.vishay.com/doc?99912



RoHS
COMPLIANT

APPLICATIONS

Over-temperature protection and control in:

- Industrial electronics
- Power supplies
- Motor protection

DESCRIPTION

These PTC sensing thermistors consist of a medium resistivity doped BaTiO₃ ceramic chip lead (Pb)-free soldered with nickel wires and coated with a high temperature silicone lacquer and color coding band.

PACKAGING

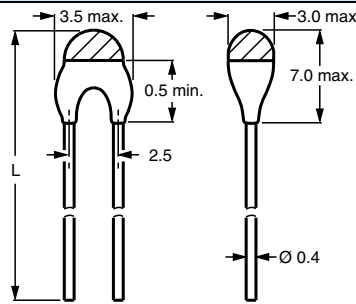
PTC thermistors are available in 500 pieces bulk packed.

QUICK REFERENCE DATA		
PARAMETER	VALUE	UNIT
Resistance at 25 °C (R_{25})	20 to 100	Ω
Nominal working temperature (T_n)	70 to 150	°C
Tolerance on T_n	± 5	°C
Maximum voltage (AC or DC)	30	V
Operating temperature range ⁽¹⁾	-20 to 165	°C
Dissipation factor	5	mW/K
Storage temperature	-25 to +155	°C

Note

⁽¹⁾ Max operating temperature range is $T_n + 15$ °C, indicated value is for $T_n = 150$ °C.

COMPONENT OUTLINES DIMENSIONS in millimeters



PTCSL20T..., L = 20 \pm 2
PTCSL40T..., L = 40 min.

NOMINAL WORKING TEMPERATURES AND ORDERING INFORMATION

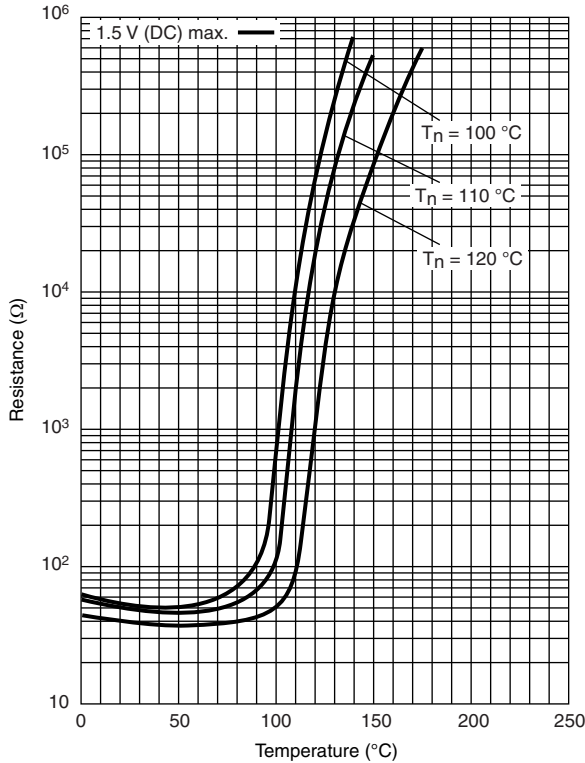
NOMINAL WORKING TEMP. T_n (°C)	RESISTANCE from -20 °C to $T_n - 20$ °C (Ω)	RESISTANCE at $T_n - 5$ °C (Ω)	RESISTANCE at $T_n + 5$ °C (k Ω)	MIN. RESISTANCE at $T_n + 15$ °C (k Ω)	COLOR CODE	ORDERING PART NUMBERS ⁽²⁾
70	20 to 250	50 to 570	0.570 to 50	4	Black	PTCSL20T071DBE
80	20 to 250	50 to 550	1.33 to 50	4	Brown	PTCSL20T081DBE
90	20 to 250	50 to 550	1.33 to 50	4	Red	PTCSL20T091DBE
100	20 to 250	50 to 550	1.33 to 50	4	Orange	PTCSL20T101DBE
110	20 to 250	50 to 550	1.33 to 50	4	Yellow	PTCSL20T111DBE
120	20 to 250	50 to 550	1.33 to 50	4	Green	PTCSL20T121DBE
130	20 to 250	50 to 550	1.33 to 50	4	Blue	PTCSL20T131DBE
140	20 to 250	50 to 550	1.33 to 50	4	Violet	PTCSL20T141DBE
150	20 to 250	50 to 550	1.33 to 50	4	Grey	PTCSL20T151DBE

Note

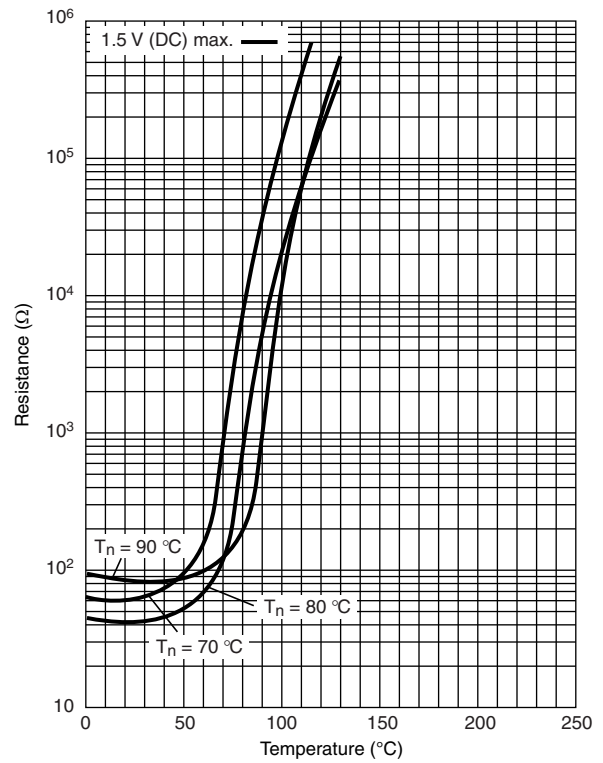
⁽²⁾ Parts with total length of 40 mm available as PTCSL40T...DBE catalog numbers.



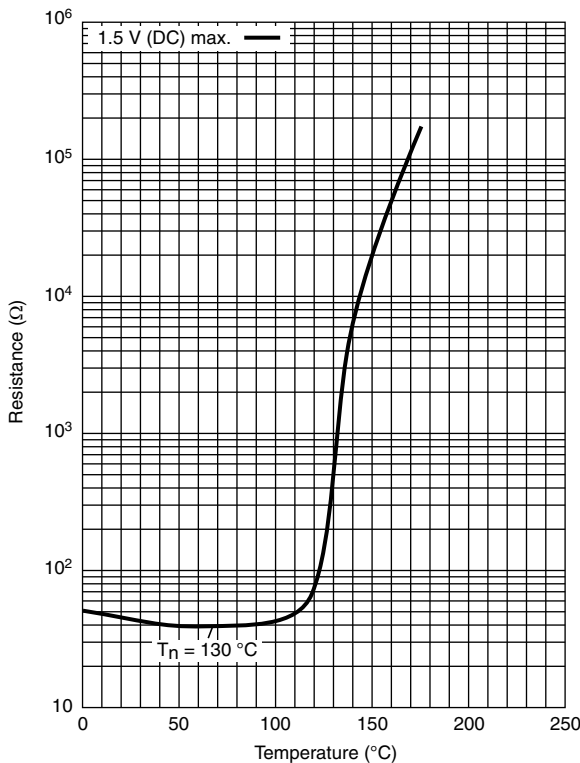
TYPICAL RESISTANCE/TEMPERATURE CHARACTERISTIC for T_n 100 °C to 120 °C



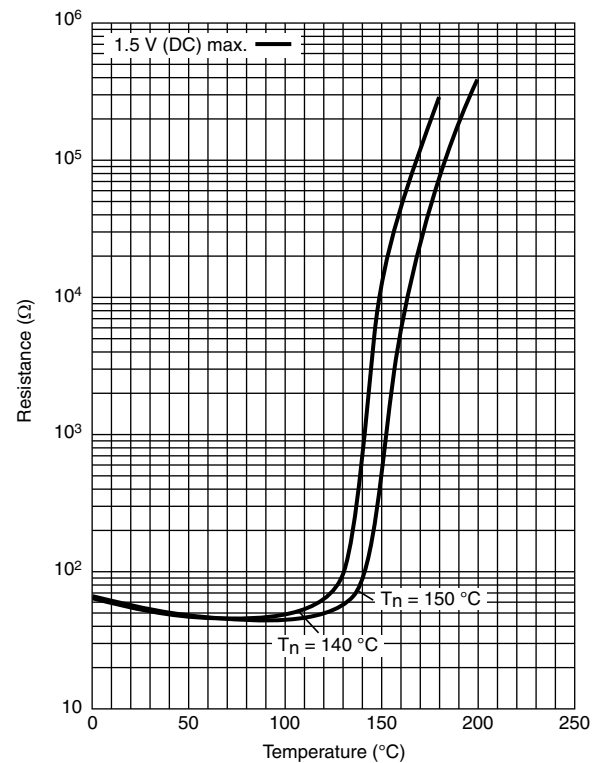
TYPICAL RESISTANCE/TEMPERATURE CHARACTERISTIC for T_n 70 °C to 90 °C



TYPICAL RESISTANCE/TEMPERATURE CHARACTERISTIC for T_n 130 °C



TYPICAL RESISTANCE/TEMPERATURE CHARACTERISTIC for T_n 140 °C and 150 °C



APPLICATION SPECIFIC DATA

Negative Temperature Coefficient (NTC) thermistors are well known for temperature sensing. What is not well known, however, is that Positive Temperature Coefficient (PTC) thermistors can be used for thermal protection. Although their operating principles are similar, the applications are very different; whereas NTC thermistors sense and measure temperature over a defined range, PTC thermistors switch at one particular temperature.

Just like thermostats they protect such equipment and components as motors, transformers, power transistors and thyristors against over temperature. A PTC thermistor is less expensive than a thermostat, and its switch temperature can be more accurately specified. It is also smaller and easier to design-in to electronic circuitry.

So how does it work? The PTC thermistor is mounted in thermal contact with the equipment to be protected, and connected into the bridge arm of a comparator circuit, such as shown in Fig. 1. At normal temperature, the PTC thermistor resistance (R_p) is lower than R_s (see Fig. 2), so the comparator's output voltage V_O will be low. If an equipment over temperature occurs, the PTC thermistor will quickly heat up to its trigger or nominal reference temperature T_n , whereupon its resistance will increase to a value much higher than R_s , causing V_O to switch to a high level sufficient to activate an alarm, relay or power shutdown circuit.

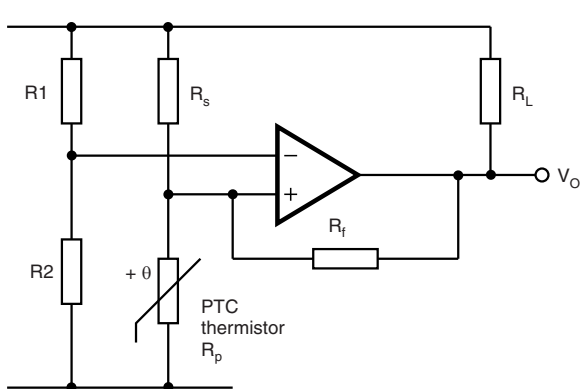
APPLICATION EXAMPLES


Fig. 1 - Typical Comparator Circuit

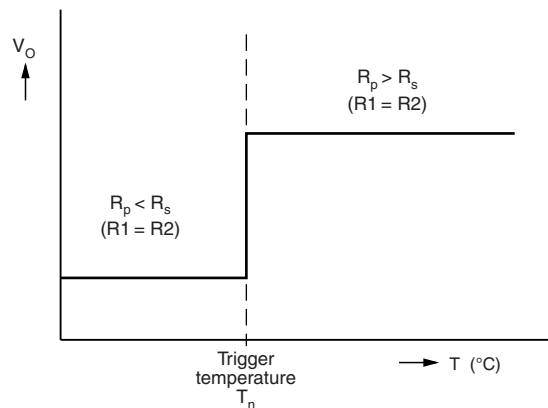
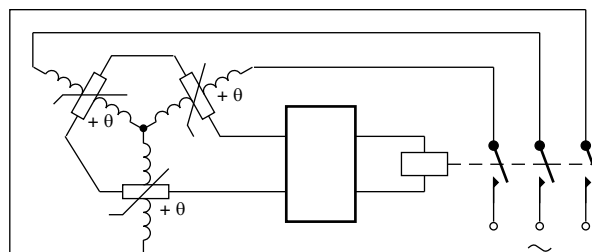


Fig. 2 - Typical Switch Characteristic



As soon as one or more of the windings becomes too hot, the motor is switched off.

Fig. 3 - Temperature Protection of 3-phase electric motor



Disclaimer

ALL PRODUCT, PRODUCT SPECIFICATIONS AND DATA ARE SUBJECT TO CHANGE WITHOUT NOTICE TO IMPROVE RELIABILITY, FUNCTION OR DESIGN OR OTHERWISE.

Vishay Intertechnology, Inc., its affiliates, agents, and employees, and all persons acting on its or their behalf (collectively, "Vishay"), disclaim any and all liability for any errors, inaccuracies or incompleteness contained in any datasheet or in any other disclosure relating to any product.

Vishay makes no warranty, representation or guarantee regarding the suitability of the products for any particular purpose or the continuing production of any product. To the maximum extent permitted by applicable law, Vishay disclaims (i) any and all liability arising out of the application or use of any product, (ii) any and all liability, including without limitation special, consequential or incidental damages, and (iii) any and all implied warranties, including warranties of fitness for particular purpose, non-infringement and merchantability.

Statements regarding the suitability of products for certain types of applications are based on Vishay's knowledge of typical requirements that are often placed on Vishay products in generic applications. Such statements are not binding statements about the suitability of products for a particular application. It is the customer's responsibility to validate that a particular product with the properties described in the product specification is suitable for use in a particular application. Parameters provided in datasheets and/or specifications may vary in different applications and performance may vary over time. All operating parameters, including typical parameters, must be validated for each customer application by the customer's technical experts. Product specifications do not expand or otherwise modify Vishay's terms and conditions of purchase, including but not limited to the warranty expressed therein.

Except as expressly indicated in writing, Vishay products are not designed for use in medical, life-saving, or life-sustaining applications or for any other application in which the failure of the Vishay product could result in personal injury or death. Customers using or selling Vishay products not expressly indicated for use in such applications do so at their own risk. Please contact authorized Vishay personnel to obtain written terms and conditions regarding products designed for such applications.

No license, express or implied, by estoppel or otherwise, to any intellectual property rights is granted by this document or by any conduct of Vishay. Product names and markings noted herein may be trademarks of their respective owners.

Material Category Policy

Vishay Intertechnology, Inc. hereby certifies that all its products that are identified as RoHS-Compliant fulfill the definitions and restrictions defined under Directive 2011/65/EU of The European Parliament and of the Council of June 8, 2011 on the restriction of the use of certain hazardous substances in electrical and electronic equipment (EEE) - recast, unless otherwise specified as non-compliant.

Please note that some Vishay documentation may still make reference to RoHS Directive 2002/95/EC. We confirm that all the products identified as being compliant to Directive 2002/95/EC conform to Directive 2011/65/EU.

Vishay Intertechnology, Inc. hereby certifies that all its products that are identified as Halogen-Free follow Halogen-Free requirements as per JEDEC JS709A standards. Please note that some Vishay documentation may still make reference to the IEC 61249-2-21 definition. We confirm that all the products identified as being compliant to IEC 61249-2-21 conform to JEDEC JS709A standards.