



15ppm/°C Max, 100µA, SOT23-3 SERIES VOLTAGE REFERENCE

FEATURES

- **MicroSIZE PACKAGE:** SOT23-3
- **LOW DROPOUT:** 5mV
- **HIGH OUTPUT CURRENT:** ±10mA
- **HIGH ACCURACY:** 0.2% max
- **LOW I_Q:** 115µA max
- **EXCELLENT SPECIFIED DRIFT PERFORMANCE:**
 - 15ppm/°C (max) from 0°C to +70°C
 - 20ppm/°C (max) from -40°C to +125°C

APPLICATIONS

- PORTABLE, BATTERY-POWERED EQUIPMENT
- DATA ACQUISITION SYSTEMS
- MEDICAL EQUIPMENT
- HAND-HELD TEST EQUIPMENT

DESCRIPTION

The REF31xx is a family of precision, low power, low dropout, series voltage references available in the tiny SOT23-3 package.

The REF31xx's small size and low power consumption (100µA typ) make it ideal for portable and battery-powered applications. The REF31xx does not require a load capacitor, but is stable with any capacitive load and can sink/source up to 10mA of output current.

Unloaded, the REF31xx can be operated on supplies down to 5mV above the output voltage. All models are specified for the wide temperature range of -40°C to +125°C.

PRODUCT	VOLTAGE (V)
REF3112	1.25
REF3120	2.048
REF3125	2.5
REF3130	3.0
REF3133	3.3
REF3140	4.096

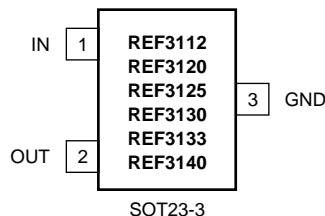

Please be aware that an important notice concerning availability, standard warranty, and use in critical applications of Texas Instruments semiconductor products and disclaimers thereto appears at the end of this data sheet.

All trademarks are the property of their respective owners.

ABSOLUTE MAXIMUM RATINGS⁽¹⁾

Supply Voltage, V+ to V-	7.0V
Output Short-Circuit	Continuous
Operating Temperature	-55°C to +135°C
Storage Temperature	-65°C to +150°C
Junction Temperature	+150°C

NOTES: (1) Stresses above these ratings may cause permanent damage. Exposure to absolute maximum conditions for extended periods may degrade device reliability. These are stress ratings only, and functional operation of the device at these, or any other conditions beyond those specified, is not implied.



ELECTROSTATIC DISCHARGE SENSITIVITY

This integrated circuit can be damaged by ESD. Texas Instruments recommends that all integrated circuits be handled with appropriate precautions. Failure to observe proper handling and installation procedures can cause damage.

ESD damage can range from subtle performance degradation to complete device failure. Precision integrated circuits may be more susceptible to damage because very small parametric changes could cause the device not to meet its published specifications.

PACKAGE/ORDERING INFORMATION⁽¹⁾

PRODUCT	PACKAGE-LEAD	PACKAGE DESIGNATOR	SPECIFIED TEMPERATURE RANGE	PACKAGE MARKING	ORDERING NUMBER	TRANSPORT MEDIA, QUANTITY
REF3112	SOT23-3	DBZ	-40°C to +125°C	R31A	REF3112AIDBZT	Tape and Reel, 250
"	"	"	"	"	REF3112AIDBZR	Tape and Reel, 3000
REF3120	SOT23-3	DBZ	-40°C to +125°C	R31B	REF3120AIDBZT	Tape and Reel, 250
"	"	"	"	"	REF3120AIDBZR	Tape and Reel, 3000
REF3125	SOT23-3	DBZ	-40°C to +125°C	R31C	REF3125AIDBZT	Tape and Reel, 250
"	"	"	"	"	REF3125AIDBZR	Tape and Reel, 3000
REF3130	SOT23-3	DBZ	-40°C to +125°C	R31E	REF3130AIDBZT	Tape and Reel, 250
"	"	"	"	"	REF3130AIDBZR	Tape and Reel, 3000
REF3133	SOT23-3	DBZ	-40°C to +125°C	R31F	REF3133AIDBZT	Tape and Reel, 250
"	"	"	"	"	REF3133AIDBZR	Tape and Reel, 3000
REF3140	SOT23-3	DBZ	-40°C to +125°C	R31D	REF3140AIDBZT	Tape and Reel, 250
"	"	"	"	"	REF3140AIDBZR	Tape and Reel, 3000

NOTE: (1) (1) For the most current package and ordering information, see the Package Option Addendum at the end of this document, or see the TI website at www.ti.com.

ELECTRICAL CHARACTERISTICS

Boldface limits apply over the specified temperature range, $T_A = -40^\circ\text{C}$ to $+125^\circ\text{C}$.

At $T_A = +25^\circ\text{C}$, $I_{\text{LOAD}} = 0\text{mA}$, $V_{\text{IN}} = 5\text{V}$, unless otherwise noted.

PARAMETER	CONDITIONS	REF31xx			UNITS
		MIN	TYP	MAX	
REF3112⁽¹⁾ - 1.25V					
OUTPUT VOLTAGE Initial Accuracy	V_{OUT}	1.2475 -0.2	1.25	1.2525 0.2	V %
NOISE Output Voltage Noise Voltage Noise	$f = 0.1\text{Hz}$ to 10Hz $f = 10\text{Hz}$ to 10kHz		17 24		μV_{PP} μV_{rms}
REF3120 - 2.048					
OUTPUT VOLTAGE Initial Accuracy	V_{OUT}	2.0439 -0.2	2.048	2.0521 0.2	V %
NOISE Output Voltage Noise Voltage Noise	$f = 0.1\text{Hz}$ to 10Hz $f = 10\text{Hz}$ to 10kHz		27 39		μV_{PP} μV_{rms}
REF3125 - 2.5V					
OUTPUT VOLTAGE Initial Accuracy	V_{OUT}	2.4950 -0.2	2.50	2.5050 0.2	V %
NOISE Output Voltage Noise Voltage Noise	$f = 0.1\text{Hz}$ to 10Hz $f = 10\text{Hz}$ to 10kHz		33 48		μV_{PP} μV_{rms}

ELECTRICAL CHARACTERISTICS

Boldface limits apply over the specified temperature range, $T_A = -40^{\circ}\text{C}$ to $+125^{\circ}\text{C}$.

At $T_A = +25^{\circ}\text{C}$, $I_{\text{LOAD}} = 0\text{mA}$, $V_{\text{IN}} = +5\text{V}$, unless otherwise noted.

PARAMETER	CONDITIONS	REF31xx			UNITS
		MIN	TYP	MAX	
REF3130 – 3.0V					
OUTPUT VOLTAGE Initial Accuracy	V_{OUT}	2.9940 -0.2	3.0	3.0060 0.2	V %
NOISE Output Voltage Noise Voltage Noise	$f = 0.1\text{Hz to }10\text{Hz}$ $f = 10\text{Hz to }10\text{kHz}$		39 57		μV_{PP} μV_{RMS}
REF3133 – 3.3V					
OUTPUT VOLTAGE Initial Accuracy	V_{OUT}	3.2934 -0.2	3.30	3.3066 0.2	V %
NOISE Output Voltage Noise Voltage Noise	$f = 0.1\text{Hz to }10\text{Hz}$ $f = 10\text{Hz to }10\text{kHz}$		43 63		μV_{PP} μV_{RMS}
REF3140 – 4.096V					
OUTPUT VOLTAGE Initial Accuracy	V_{OUT}	4.0878 -0.2	4.096	4.1042 0.2	V %
NOISE Output Voltage Noise Voltage Noise	$f = 0.1\text{Hz to }10\text{Hz}$ $f = 10\text{Hz to }10\text{kHz}$		53 78		μV_{PP} μV_{RMS}
REF3112, REF3120, REF3125, REF3130, REF3133, REF3140					
OUTPUT VOLTAGE TEMP DRIFT ⁽²⁾	dV_{OUT}/dT	$0^{\circ}\text{C} \leq T_A \leq +70^{\circ}\text{C}$ $-40^{\circ}\text{C} \leq T_A \leq +125^{\circ}\text{C}$	5 10	15 20	ppm/°C ppm/°C
LONG-TERM STABILITY		0-1000h	70		ppm
LINE REGULATION		$V_{\text{REF}} + 0.05^{(1)} \leq V_{\text{IN}} \leq 5.5\text{V}$	20	65	ppm/V
LOAD REGULATION ⁽³⁾	$dV_{\text{OUT}}/dI_{\text{LOAD}}$	$0\text{mA} < I_{\text{LOAD}} < 10\text{mA}$, $V_{\text{IN}} = V_{\text{REF}} + 250\text{mV}^{(1)}$ Sourcing $-10\text{mA} < I_{\text{LOAD}} < 0\text{mA}$, $V_{\text{IN}} = V_{\text{REF}} + 100\text{mV}^{(1)}$ Sinking	10 20	30 50	$\mu\text{V}/\text{mA}$ $\mu\text{V}/\text{mA}$
THERMAL HYSTERESIS ⁽⁴⁾		dT		100 25	ppm ppm
DROPOUT VOLTAGE ⁽¹⁾	$V_{\text{IN}} - V_{\text{OUT}}$		5	50	mV
OUTPUT CURRENT	I_{LOAD}		-10	10	mA
SHORT-CIRCUIT CURRENT	I_{SC}			50 40	mA mA
TURN-ON SETTLING TIME		to 0.1% at $V_{\text{IN}} = +5\text{V}$ with $C_L = 0$	400		μs
POWER SUPPLY		$I_L = 0$			
Voltage	V_S		$V_{\text{REF}} + 0.05^{(1)}$	5.5	V
Quiescent Current	I_Q		100	115	μA
Over Temperature			115	135	μA
TEMPERATURE RANGE					
Specified Range			-40	+125	°C
Operating Range			-55	+135	°C
Storage Range			-65	+150	°C
Thermal Resistance SOT23-3 Surface-Mount	θ_{JA}		336		°C/W

NOTES: (1) Minimum supply voltage for REF3112 is 1.8V.

(2) Box Method used to determine temperature drift.

(3) Typical value of load regulation reflects measurements using force and sense contacts; see the *Load Regulation* section.

(4) Thermal hysteresis is explained in more detail in the *Applications Information* section of this data sheet.

(5) For $I_L > 0$, see the Typical Characteristic curves.

TYPICAL CHARACTERISTICS

At $T_A = +25^\circ\text{C}$, $V_{IN} = +5\text{V}$ power supply, REF3125 is used for typical characteristics, unless otherwise noted.

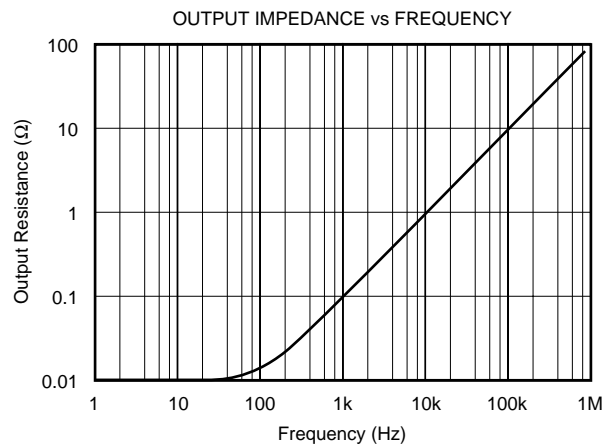
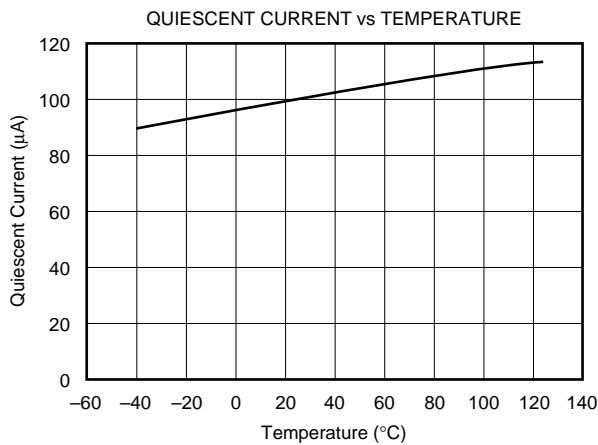
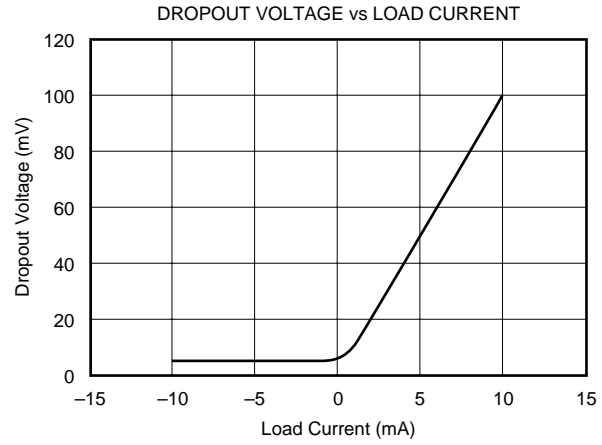
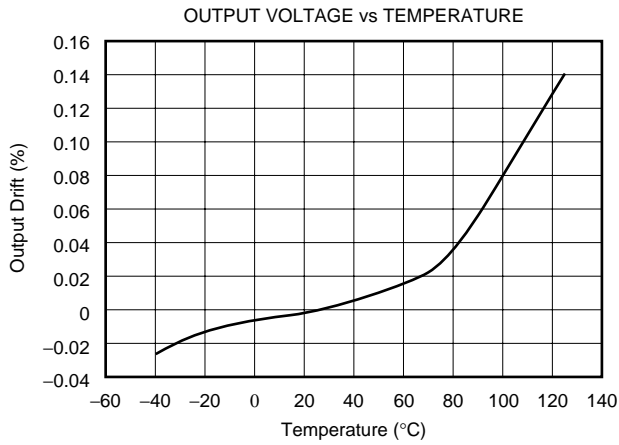
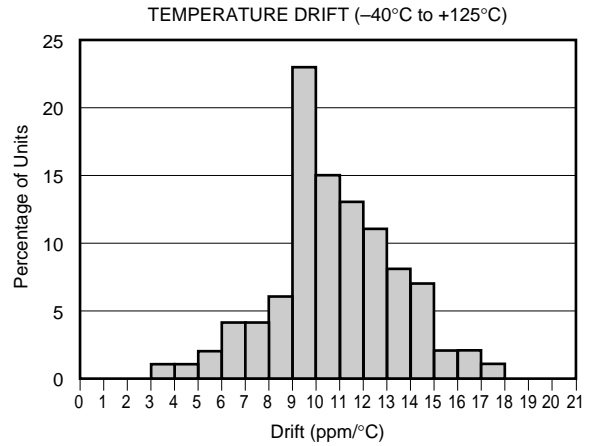
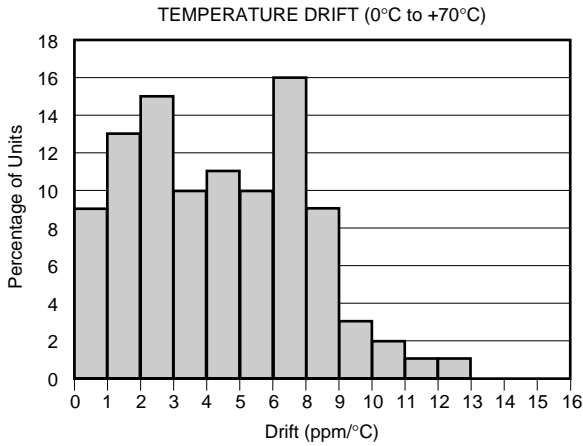

TYPICAL CHARACTERISTICS (Cont.)

At $T_A = +25^\circ\text{C}$, $V_{IN} = +5\text{V}$ power supply, REF3125 is used for typical characteristics, unless otherwise noted.

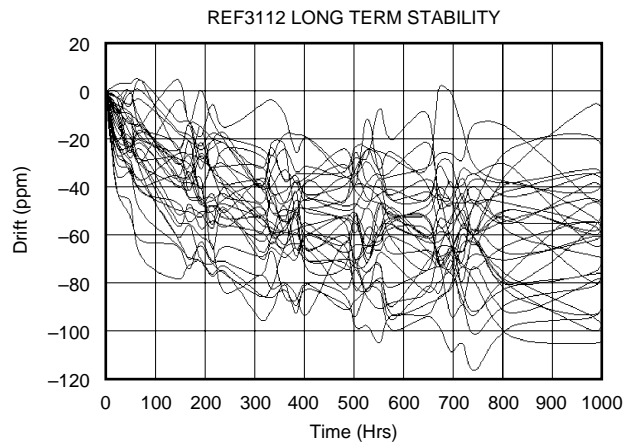
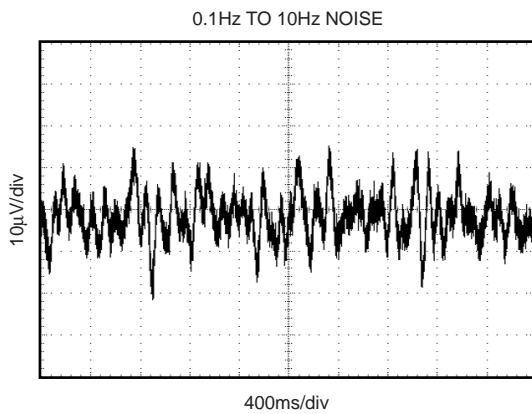
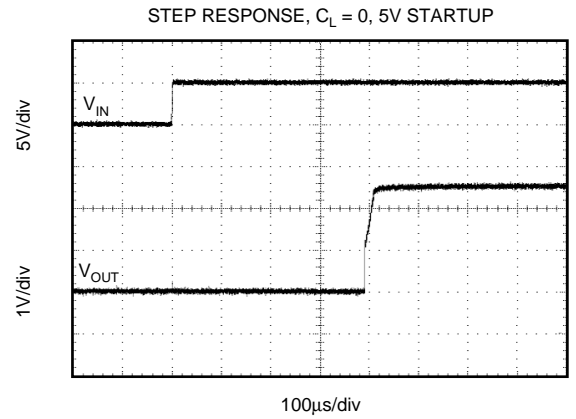
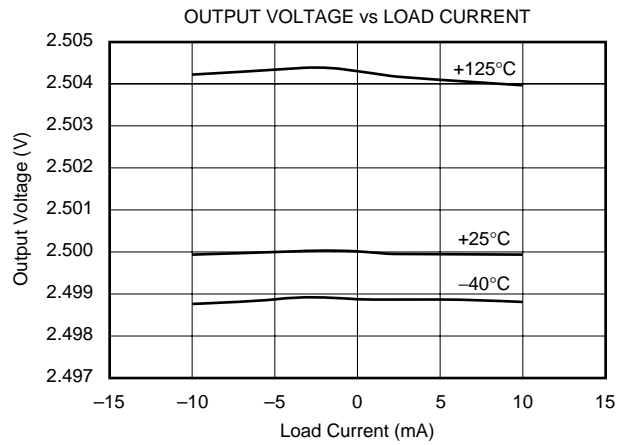
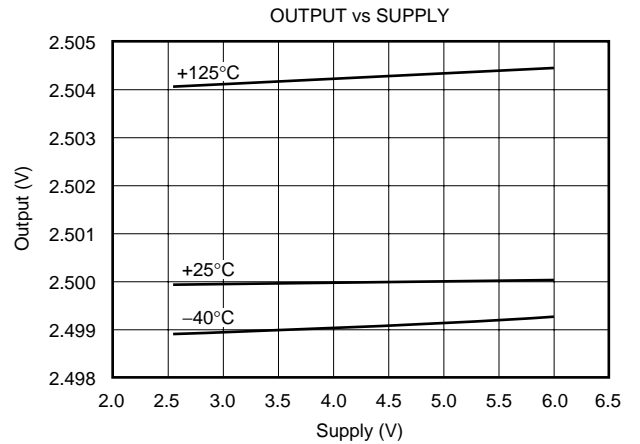
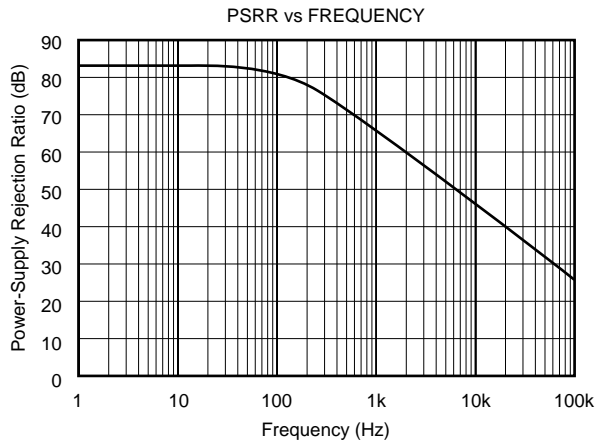

TYPICAL CHARACTERISTICS (Cont.)

At $T_A = +25^\circ\text{C}$, $V_{IN} = +5\text{V}$ power supply, REF3125 is used for typical characteristics, unless otherwise noted.

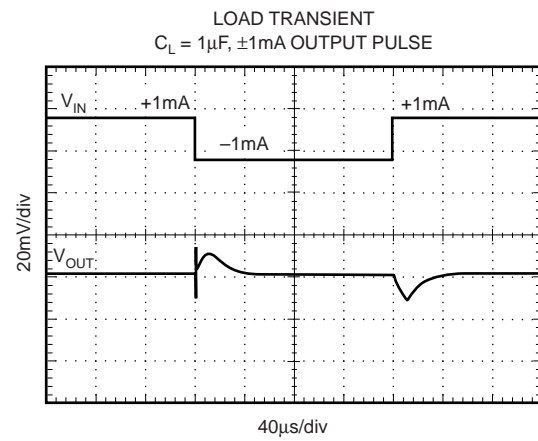
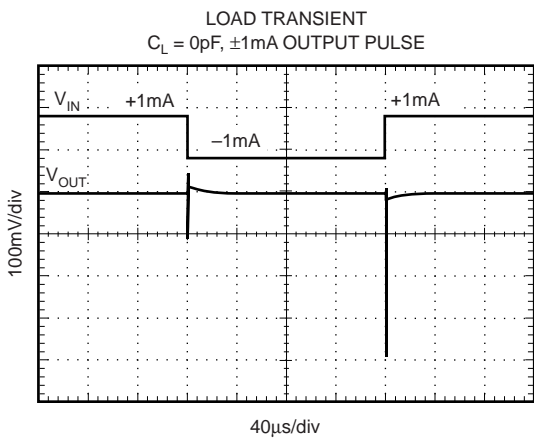
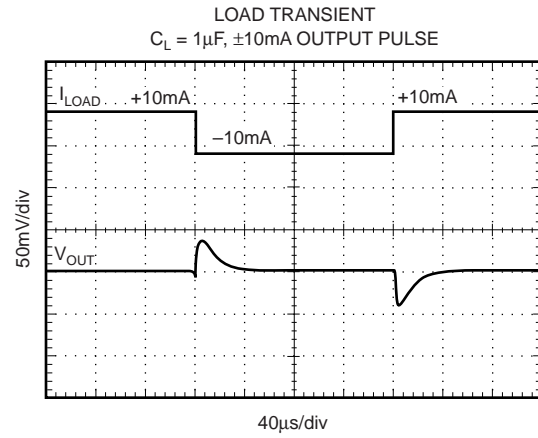
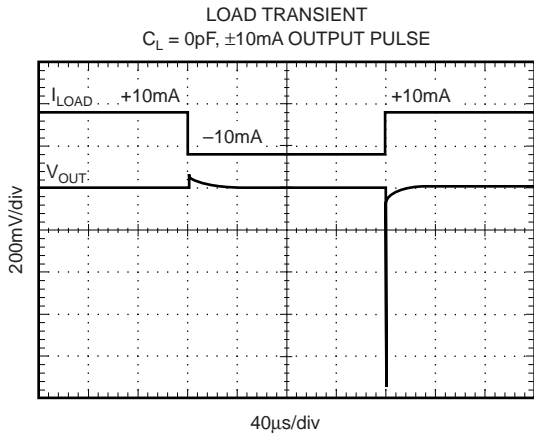
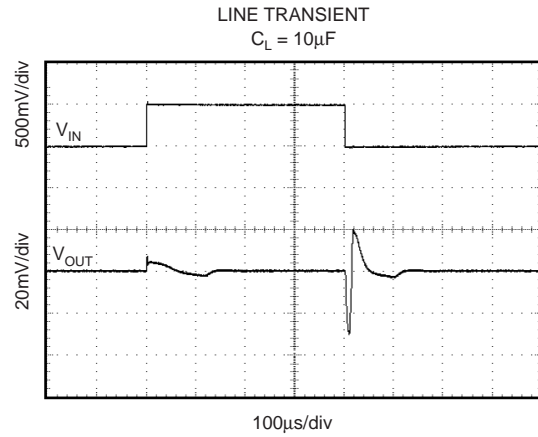
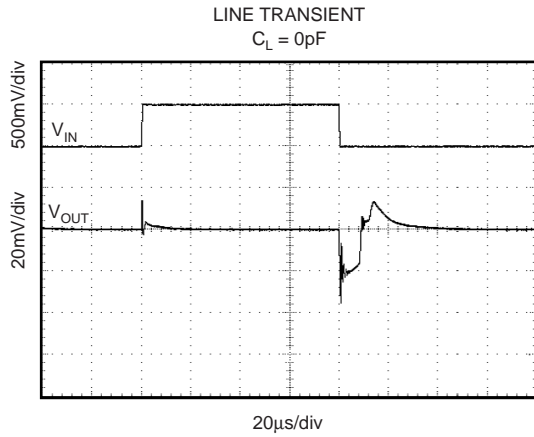

THEORY OF OPERATION

The REF31xx is a family of series, CMOS, precision bandgap voltage references. The basic bandgap topology is shown in Figure 1. Transistors Q_1 and Q_2 are biased such that the current density of Q_1 is greater than that of Q_2 . The difference of the two base-emitter voltages, $V_{be1} - V_{be2}$, has a positive temperature coefficient and is forced across resistor R_1 . This voltage is gained up and added to the base-emitter voltage of Q_2 , which has a negative temperature coefficient. The resulting output voltage is virtually independent of temperature.

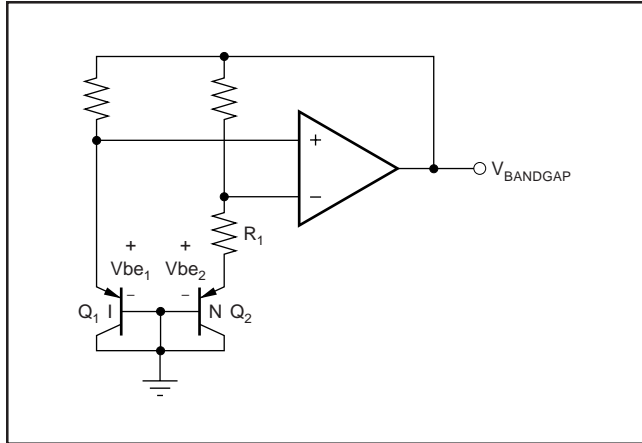

FIGURE 1. Simplified Schematic of Bandgap Reference.

APPLICATION INFORMATION

The REF31xx does not require a load capacitor and is stable with any capacitive load. Figure 2 shows typical connections required for operation of the REF31xx. A supply bypass capacitor of $0.47\mu\text{F}$ is recommended.

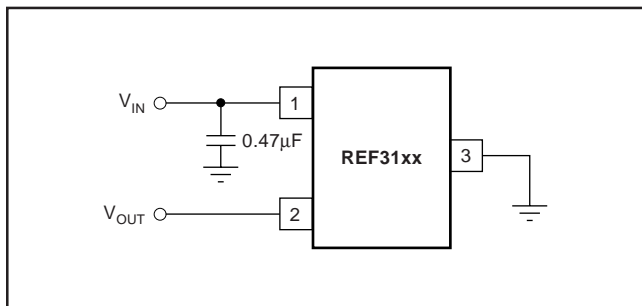

FIGURE 2. Typical Connections for Operating REF31xx.

SUPPLY VOLTAGE

The REF31xx family of references features an extremely low dropout voltage. With the exception of the REF3112, which has a minimum supply requirement of 1.8V, these references can be operated with a supply of only 5mV above the output voltage in an unloaded condition. For loaded conditions, a typical dropout voltage versus load is shown in the typical curves.

The REF31xx features a low quiescent current, which is extremely stable over changes in both temperature and supply. The typical room temperature quiescent current is

$100\mu\text{A}$, and the maximum quiescent current over temperature is just $135\mu\text{A}$. The quiescent current typically changes less than $2\mu\text{A}$ over the entire supply range, as shown in Figure 3.

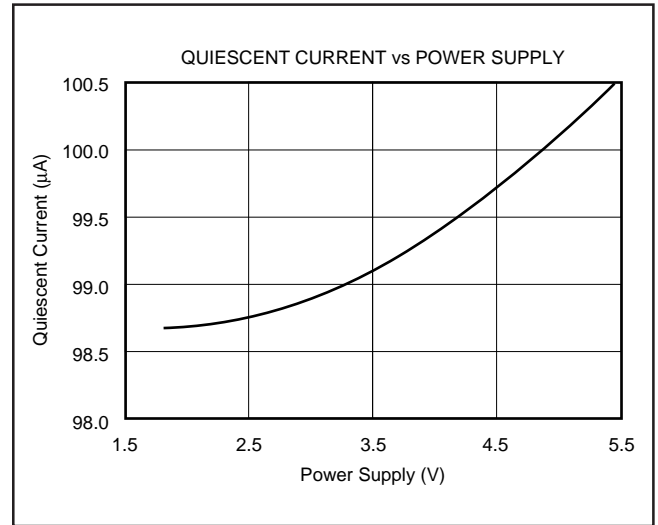

FIGURE 3. Supply Current vs Supply Voltage.

Supply voltages below the specified levels can cause the REF31xx to momentarily draw currents greater than the typical quiescent current. This can be prevented by using a power supply with a fast rising edge and low output impedance.

THERMAL HYSTERESIS

Thermal hysteresis for the REF31xx is defined as the change in output voltage after operating the device at 25°C , cycling the device through the specified temperature range, and returning to 25°C . It can be expressed as:

$$V_{\text{HYST}} = \left(\frac{\text{abs}|V_{\text{PRE}} - V_{\text{POST}}|}{V_{\text{NOM}}} \right) \cdot 10^6 (\text{ppm})$$

Where: V_{HYST} = Thermal hysteresis

V_{PRE} = Output voltage measured at 25°C pre-temperature cycling

V_{POST} = Output voltage measured after the device has been cycled through the specified temperature range of -40°C to $+125^\circ\text{C}$ and returned to 25°C .

TEMPERATURE DRIFT

The REF31xx is designed to exhibit minimal drift error, defined as the change in output voltage over varying temperature. The drift is calculated using the "box" method which is described by the following equation:

$$\left(\frac{V_{\text{OUTMAX}} - V_{\text{OUTMIN}}}{V_{\text{OUT}} \cdot \text{TemperatureRange}} \right) \cdot 10^6 \text{ppm}$$

The REF31xx features a typical drift coefficient of 5ppm from 0°C to 70°C —the primary temperature range for many applications. For the industrial temperature range of -40°C to 125°C , the REF31xx family drift increases to a typical value of 10ppm.

NOISE PERFORMANCE

Typical 0.1Hz to 10Hz voltage noise can be seen in the Typical Characteristic Curve, *0.1 to 10Hz Voltage Noise*. The noise voltage of the REF31xx increases with output voltage and operating temperature. Additional filtering may be used to improve output noise levels, although care should be taken to ensure the output impedance does not degrade the AC performance.

LONG-TERM STABILITY

Long-term stability refers to the change of the output voltage of a reference over a period of months or years. This effect lessens as time progresses, as is shown by the long-term stability curves. The typical drift value for the REF31xx is 70ppm from 0-1000 hours. This parameter is characterized by measuring 30 units at regular intervals for a period of 1000 hours.

LOAD REGULATION

Load regulation is defined as the change in output voltage due to changes in load current. The load regulation of the REF31xx is measured using force and sense contacts as pictured in Figure 4. The force and sense lines reduce the impact of contact and trace resistance, resulting in accurate measurement of the load regulation contributed solely by the REF31xx. For applications requiring improved load regulation, force and sense lines should be used.

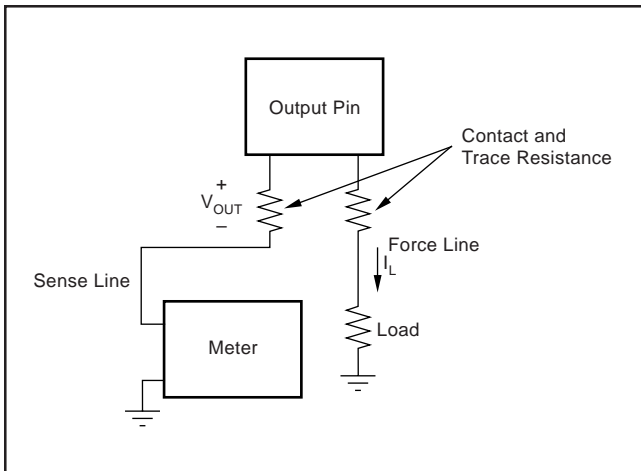

FIGURE 4. Accurate Load Regulation of REF31xx.

APPLICATION CIRCUITS

Negative Reference Voltage

For applications requiring a negative and positive reference voltage, the REF31xx and OPA703 can be used to provide a dual supply reference from a $\pm 5V$ supply. Figure 5 shows the REF3125 used to provide a $\pm 2.5V$ supply reference voltage. The low drift performance of the REF31xx complement the low offset voltage and low drift of the OPA703 to provide an accurate solution for split-supply applications.

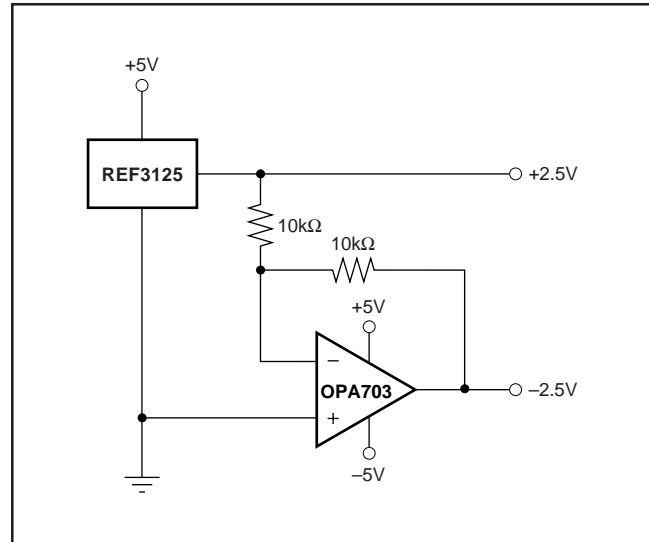

FIGURE 5. REF3125 Combined with OPA703 to Create Positive and Negative Reference Voltages.

DATA ACQUISITION

Data acquisition systems often require stable voltage references to maintain accuracy. The REF31xx family features stability and a wide range of voltages suitable for most micro-controllers and data converters. Figure 6, Figure 7, and Figure 8 show basic data acquisition systems.

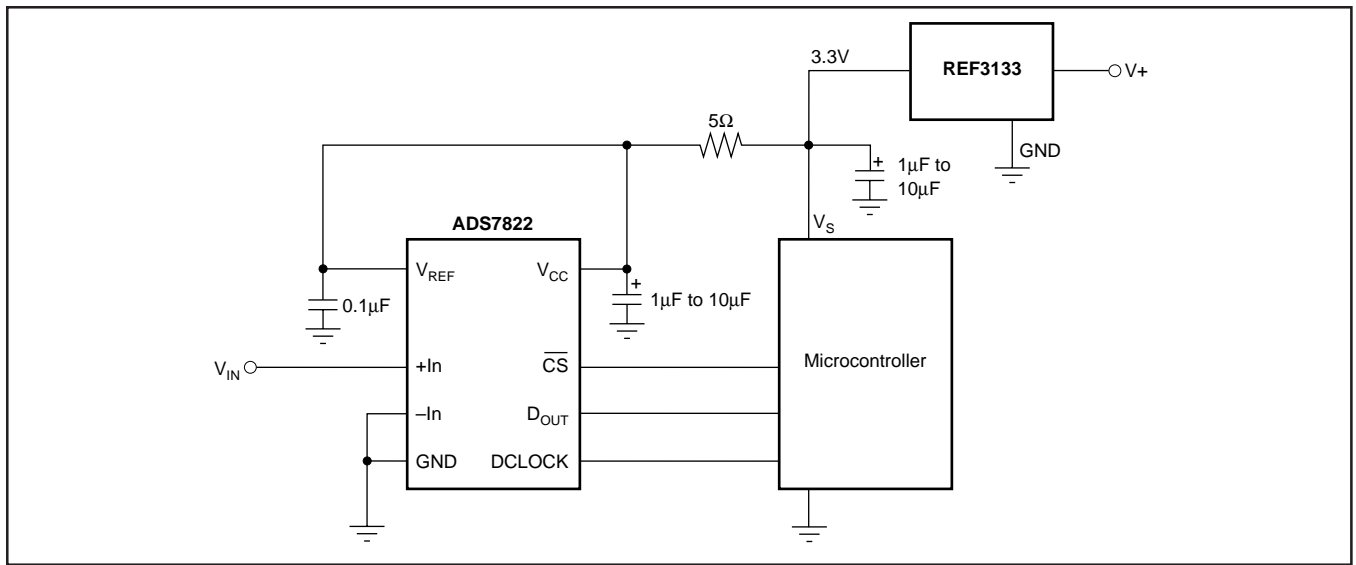

FIGURE 6. Basic Data Acquisition System 1.

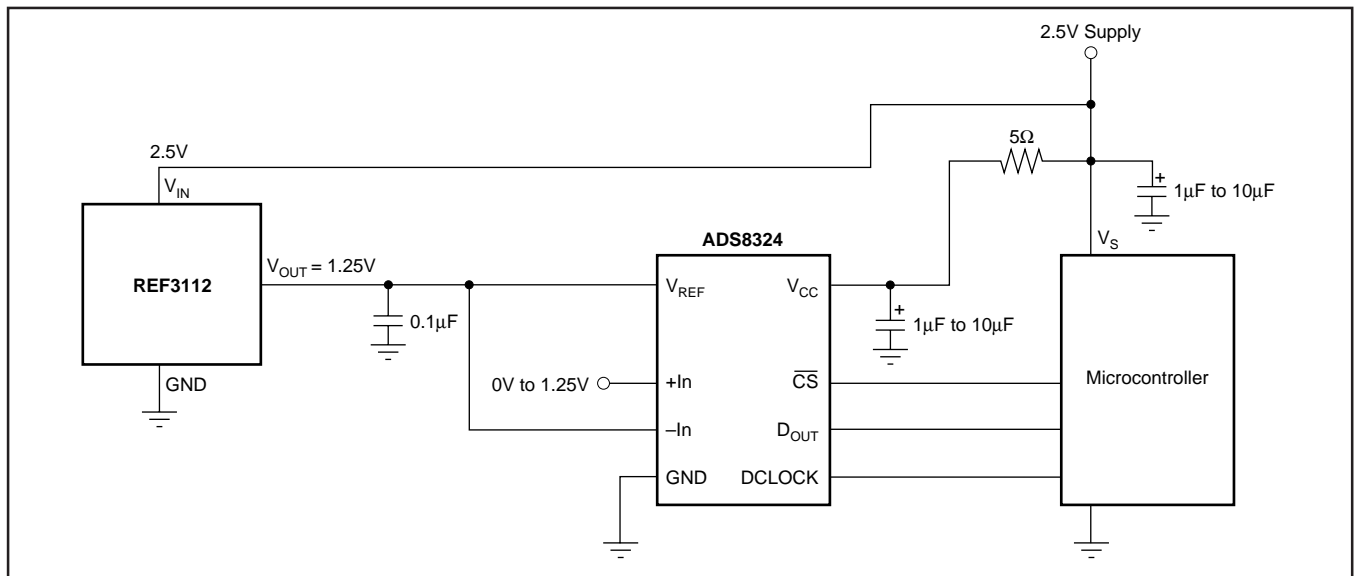

FIGURE 7. Basic Data Acquisition System 2.

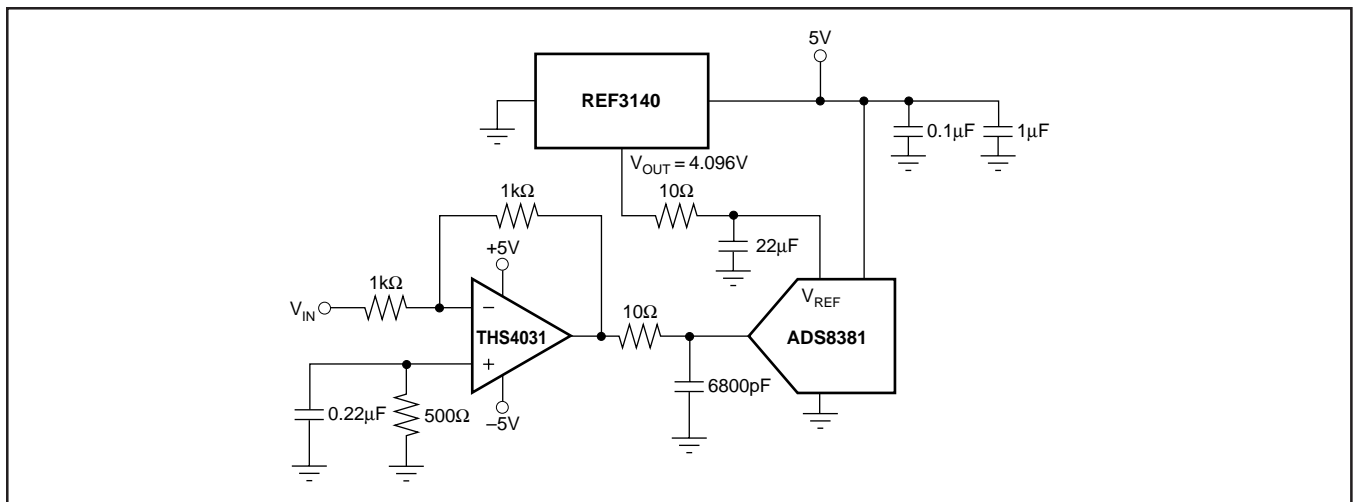

FIGURE 8. REF3140 Provides an Accurate Reference for Driving the ADS8381.

PACKAGING INFORMATION

Orderable Device	Status (1)	Package Type	Package Drawing	Pins	Package Qty	Eco Plan (2)	Lead/Ball Finish (6)	MSL Peak Temp (3)	Op Temp (°C)	Device Marking (4/5)	Samples
REF3112AIDBZR	ACTIVE	SOT-23	DBZ	3	3000	Green (RoHS & no Sb/Br)	CU NIPDAU	Level-1-260C-UNLIM		R31A	Samples
REF3112AIDBZRG4	ACTIVE	SOT-23	DBZ	3	3000	Green (RoHS & no Sb/Br)	CU NIPDAU	Level-1-260C-UNLIM		R31A	Samples
REF3112AIDBZT	ACTIVE	SOT-23	DBZ	3	250	Green (RoHS & no Sb/Br)	CU NIPDAU	Level-1-260C-UNLIM		R31A	Samples
REF3112AIDBZTG4	ACTIVE	SOT-23	DBZ	3	250	Green (RoHS & no Sb/Br)	CU NIPDAU	Level-1-260C-UNLIM		R31A	Samples
REF3120AIDBZR	ACTIVE	SOT-23	DBZ	3	3000	Green (RoHS & no Sb/Br)	CU NIPDAU	Level-1-260C-UNLIM	-40 to 125	R31B	Samples
REF3120AIDBZRG4	ACTIVE	SOT-23	DBZ	3	3000	Green (RoHS & no Sb/Br)	CU NIPDAU	Level-1-260C-UNLIM	-40 to 125	R31B	Samples
REF3120AIDBZT	ACTIVE	SOT-23	DBZ	3	250	Green (RoHS & no Sb/Br)	CU NIPDAU	Level-1-260C-UNLIM	-40 to 125	R31B	Samples
REF3120AIDBZTG4	ACTIVE	SOT-23	DBZ	3	250	Green (RoHS & no Sb/Br)	CU NIPDAU	Level-1-260C-UNLIM	-40 to 125	R31B	Samples
REF3125AIDBZR	ACTIVE	SOT-23	DBZ	3	3000	Green (RoHS & no Sb/Br)	CU NIPDAU	Level-1-260C-UNLIM	-40 to 125	R31C	Samples
REF3125AIDBZRG4	ACTIVE	SOT-23	DBZ	3	3000	Green (RoHS & no Sb/Br)	CU NIPDAU	Level-1-260C-UNLIM	-40 to 125	R31C	Samples
REF3125AIDBZT	ACTIVE	SOT-23	DBZ	3	250	Green (RoHS & no Sb/Br)	CU NIPDAU	Level-1-260C-UNLIM	-40 to 125	R31C	Samples
REF3125AIDBZTG4	ACTIVE	SOT-23	DBZ	3	250	Green (RoHS & no Sb/Br)	CU NIPDAU	Level-1-260C-UNLIM	-40 to 125	R31C	Samples
REF3130AIDBZR	ACTIVE	SOT-23	DBZ	3	3000	Green (RoHS & no Sb/Br)	CU NIPDAU	Level-1-260C-UNLIM	-40 to 125	R31E	Samples
REF3130AIDBZRG4	ACTIVE	SOT-23	DBZ	3	3000	Green (RoHS & no Sb/Br)	CU NIPDAU	Level-1-260C-UNLIM	-40 to 125	R31E	Samples
REF3130AIDBZT	ACTIVE	SOT-23	DBZ	3	250	Green (RoHS & no Sb/Br)	CU NIPDAU	Level-1-260C-UNLIM	-40 to 125	R31E	Samples
REF3130AIDBZTG4	ACTIVE	SOT-23	DBZ	3	250	Green (RoHS & no Sb/Br)	CU NIPDAU	Level-1-260C-UNLIM	-40 to 125	R31E	Samples
REF3133AIDBZR	ACTIVE	SOT-23	DBZ	3	3000	Green (RoHS & no Sb/Br)	CU NIPDAU	Level-1-260C-UNLIM	-40 to 125	R31F	Samples

Orderable Device	Status (1)	Package Type	Package Drawing	Pins	Package Qty	Eco Plan (2)	Lead/Ball Finish (6)	MSL Peak Temp (3)	Op Temp (°C)	Device Marking (4/5)	Samples
REF3133AIDBZRG4	ACTIVE	SOT-23	DBZ	3	3000	Green (RoHS & no Sb/Br)	CU NIPDAU	Level-1-260C-UNLIM	-40 to 125	R31F	Samples
REF3133AIDBZT	ACTIVE	SOT-23	DBZ	3	250	Green (RoHS & no Sb/Br)	CU NIPDAU	Level-1-260C-UNLIM	-40 to 125	R31F	Samples
REF3133AIDBZTG4	ACTIVE	SOT-23	DBZ	3	250	Green (RoHS & no Sb/Br)	CU NIPDAU	Level-1-260C-UNLIM	-40 to 125	R31F	Samples
REF3140AIDBZR	ACTIVE	SOT-23	DBZ	3	3000	Green (RoHS & no Sb/Br)	CU NIPDAU	Level-1-260C-UNLIM	-40 to 125	R31D	Samples
REF3140AIDBZRG4	ACTIVE	SOT-23	DBZ	3	3000	Green (RoHS & no Sb/Br)	CU NIPDAU	Level-1-260C-UNLIM	-40 to 125	R31D	Samples
REF3140AIDBZT	ACTIVE	SOT-23	DBZ	3	250	Green (RoHS & no Sb/Br)	CU NIPDAU	Level-1-260C-UNLIM	-40 to 125	R31D	Samples
REF3140AIDBZTG4	ACTIVE	SOT-23	DBZ	3	250	Green (RoHS & no Sb/Br)	CU NIPDAU	Level-1-260C-UNLIM	-40 to 125	R31D	Samples

(1) The marketing status values are defined as follows:

ACTIVE: Product device recommended for new designs.

LIFEBUY: TI has announced that the device will be discontinued, and a lifetime-buy period is in effect.

NRND: Not recommended for new designs. Device is in production to support existing customers, but TI does not recommend using this part in a new design.

PREVIEW: Device has been announced but is not in production. Samples may or may not be available.

OBSOLETE: TI has discontinued the production of the device.

(2) Eco Plan - The planned eco-friendly classification: Pb-Free (RoHS), Pb-Free (RoHS Exempt), or Green (RoHS & no Sb/Br) - please check <http://www.ti.com/productcontent> for the latest availability information and additional product content details.

TBD: The Pb-Free/Green conversion plan has not been defined.

Pb-Free (RoHS): TI's terms "Lead-Free" or "Pb-Free" mean semiconductor products that are compatible with the current RoHS requirements for all 6 substances, including the requirement that lead not exceed 0.1% by weight in homogeneous materials. Where designed to be soldered at high temperatures, TI Pb-Free products are suitable for use in specified lead-free processes.

Pb-Free (RoHS Exempt): This component has a RoHS exemption for either 1) lead-based flip-chip solder bumps used between the die and package, or 2) lead-based die adhesive used between the die and leadframe. The component is otherwise considered Pb-Free (RoHS compatible) as defined above.

Green (RoHS & no Sb/Br): TI defines "Green" to mean Pb-Free (RoHS compatible), and free of Bromine (Br) and Antimony (Sb) based flame retardants (Br or Sb do not exceed 0.1% by weight in homogeneous material)

(3) MSL, Peak Temp. - The Moisture Sensitivity Level rating according to the JEDEC industry standard classifications, and peak solder temperature.

(4) There may be additional marking, which relates to the logo, the lot trace code information, or the environmental category on the device.

(5) Multiple Device Markings will be inside parentheses. Only one Device Marking contained in parentheses and separated by a "~" will appear on a device. If a line is indented then it is a continuation of the previous line and the two combined represent the entire Device Marking for that device.

⁽⁶⁾ Lead/Ball Finish - Orderable Devices may have multiple material finish options. Finish options are separated by a vertical ruled line. Lead/Ball Finish values may wrap to two lines if the finish value exceeds the maximum column width.

Important Information and Disclaimer: The information provided on this page represents TI's knowledge and belief as of the date that it is provided. TI bases its knowledge and belief on information provided by third parties, and makes no representation or warranty as to the accuracy of such information. Efforts are underway to better integrate information from third parties. TI has taken and continues to take reasonable steps to provide representative and accurate information but may not have conducted destructive testing or chemical analysis on incoming materials and chemicals. TI and TI suppliers consider certain information to be proprietary, and thus CAS numbers and other limited information may not be available for release.

In no event shall TI's liability arising out of such information exceed the total purchase price of the TI part(s) at issue in this document sold by TI to Customer on an annual basis.

TAPE AND REEL INFORMATION



QUADRANT ASSIGNMENTS FOR PIN 1 ORIENTATION IN TAPE



*All dimensions are nominal

Device	Package Type	Package Drawing	Pins	SPQ	Reel Diameter (mm)	Reel Width W1 (mm)	A0 (mm)	B0 (mm)	K0 (mm)	P1 (mm)	W (mm)	Pin1 Quadrant
REF3112AIDBZR	SOT-23	DBZ	3	3000	179.0	8.4	3.15	2.95	1.22	4.0	8.0	Q3
REF3112AIDBZT	SOT-23	DBZ	3	250	179.0	8.4	3.15	2.95	1.22	4.0	8.0	Q3
REF3120AIDBZR	SOT-23	DBZ	3	3000	179.0	8.4	3.15	2.95	1.22	4.0	8.0	Q3
REF3120AIDBZT	SOT-23	DBZ	3	250	179.0	8.4	3.15	2.95	1.22	4.0	8.0	Q3
REF3125AIDBZR	SOT-23	DBZ	3	3000	179.0	8.4	3.15	2.95	1.22	4.0	8.0	Q3
REF3125AIDBZT	SOT-23	DBZ	3	250	179.0	8.4	3.15	2.95	1.22	4.0	8.0	Q3
REF3130AIDBZR	SOT-23	DBZ	3	3000	179.0	8.4	3.15	2.95	1.22	4.0	8.0	Q3
REF3130AIDBZT	SOT-23	DBZ	3	250	179.0	8.4	3.15	2.95	1.22	4.0	8.0	Q3
REF3133AIDBZR	SOT-23	DBZ	3	3000	179.0	8.4	3.15	2.95	1.22	4.0	8.0	Q3
REF3133AIDBZT	SOT-23	DBZ	3	250	179.0	8.4	3.15	2.95	1.22	4.0	8.0	Q3
REF3140AIDBZR	SOT-23	DBZ	3	3000	179.0	8.4	3.15	2.95	1.22	4.0	8.0	Q3
REF3140AIDBZT	SOT-23	DBZ	3	250	179.0	8.4	3.15	2.95	1.22	4.0	8.0	Q3

TAPE AND REEL BOX DIMENSIONS

*All dimensions are nominal

Device	Package Type	Package Drawing	Pins	SPQ	Length (mm)	Width (mm)	Height (mm)
REF3112AIDBZR	SOT-23	DBZ	3	3000	203.0	203.0	35.0
REF3112AIDBZT	SOT-23	DBZ	3	250	203.0	203.0	35.0
REF3120AIDBZR	SOT-23	DBZ	3	3000	203.0	203.0	35.0
REF3120AIDBZT	SOT-23	DBZ	3	250	203.0	203.0	35.0
REF3125AIDBZR	SOT-23	DBZ	3	3000	203.0	203.0	35.0
REF3125AIDBZT	SOT-23	DBZ	3	250	203.0	203.0	35.0
REF3130AIDBZR	SOT-23	DBZ	3	3000	203.0	203.0	35.0
REF3130AIDBZT	SOT-23	DBZ	3	250	203.0	203.0	35.0
REF3133AIDBZR	SOT-23	DBZ	3	3000	203.0	203.0	35.0
REF3133AIDBZT	SOT-23	DBZ	3	250	203.0	203.0	35.0
REF3140AIDBZR	SOT-23	DBZ	3	3000	203.0	203.0	35.0
REF3140AIDBZT	SOT-23	DBZ	3	250	203.0	203.0	35.0

DBZ (R-PDSO-G3)

PLASTIC SMALL-OUTLINE

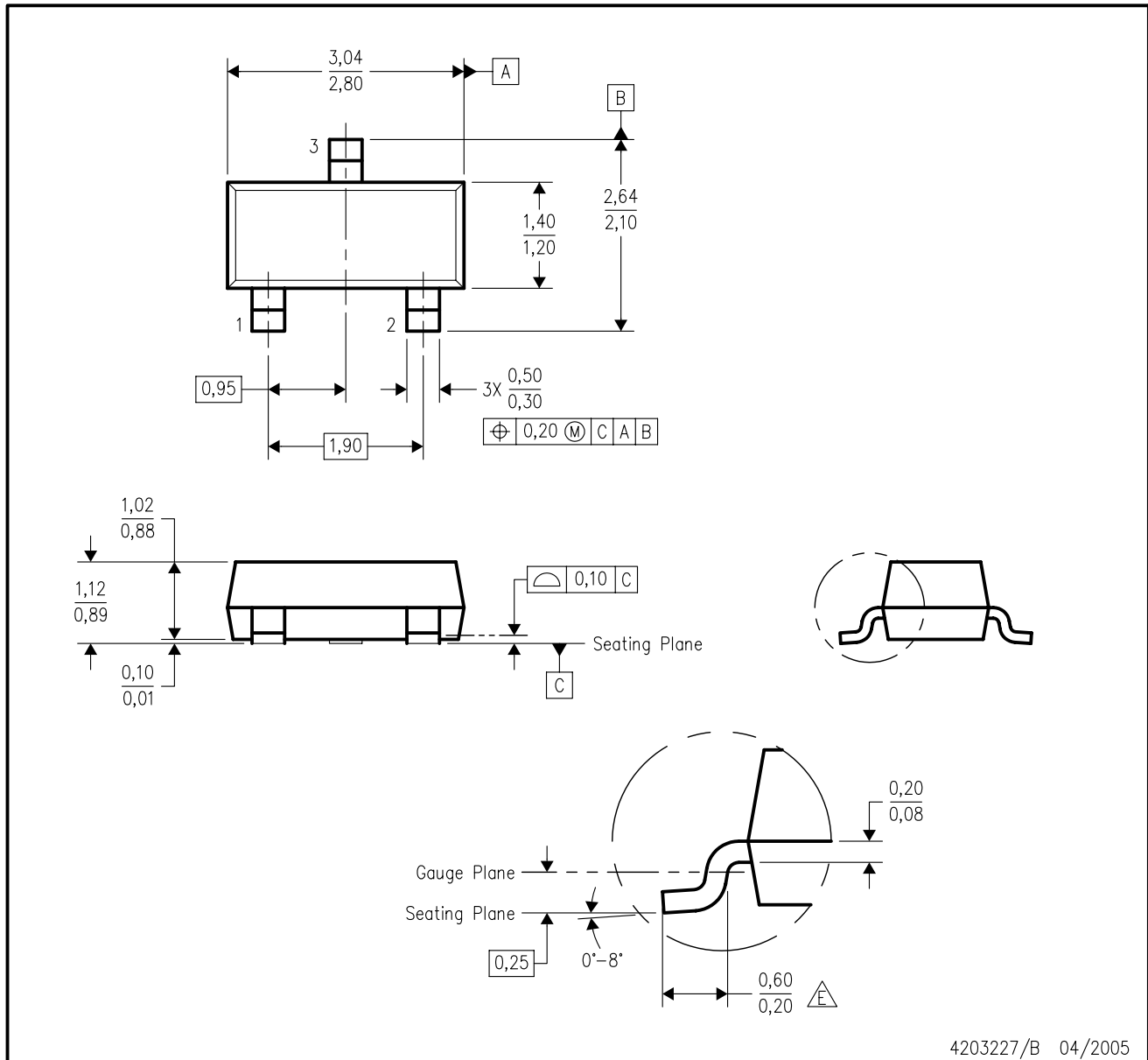

- NOTES:
- A. All linear dimensions are in millimeters. Dimensioning and tolerancing per ASME Y14.5M-1994.
 - B. This drawing is subject to change without notice.
 - C. Lead dimensions are inclusive of plating.
 - D. Body dimensions are exclusive of mold flash and protrusion. Mold flash and protrusion not to exceed 0.25 per side.
 - $\triangle E$ Falls within JEDEC TO-236 variation AB, except minimum foot length.

DBZ (R-PDSO-G3)

PLASTIC SMALL OUTLINE

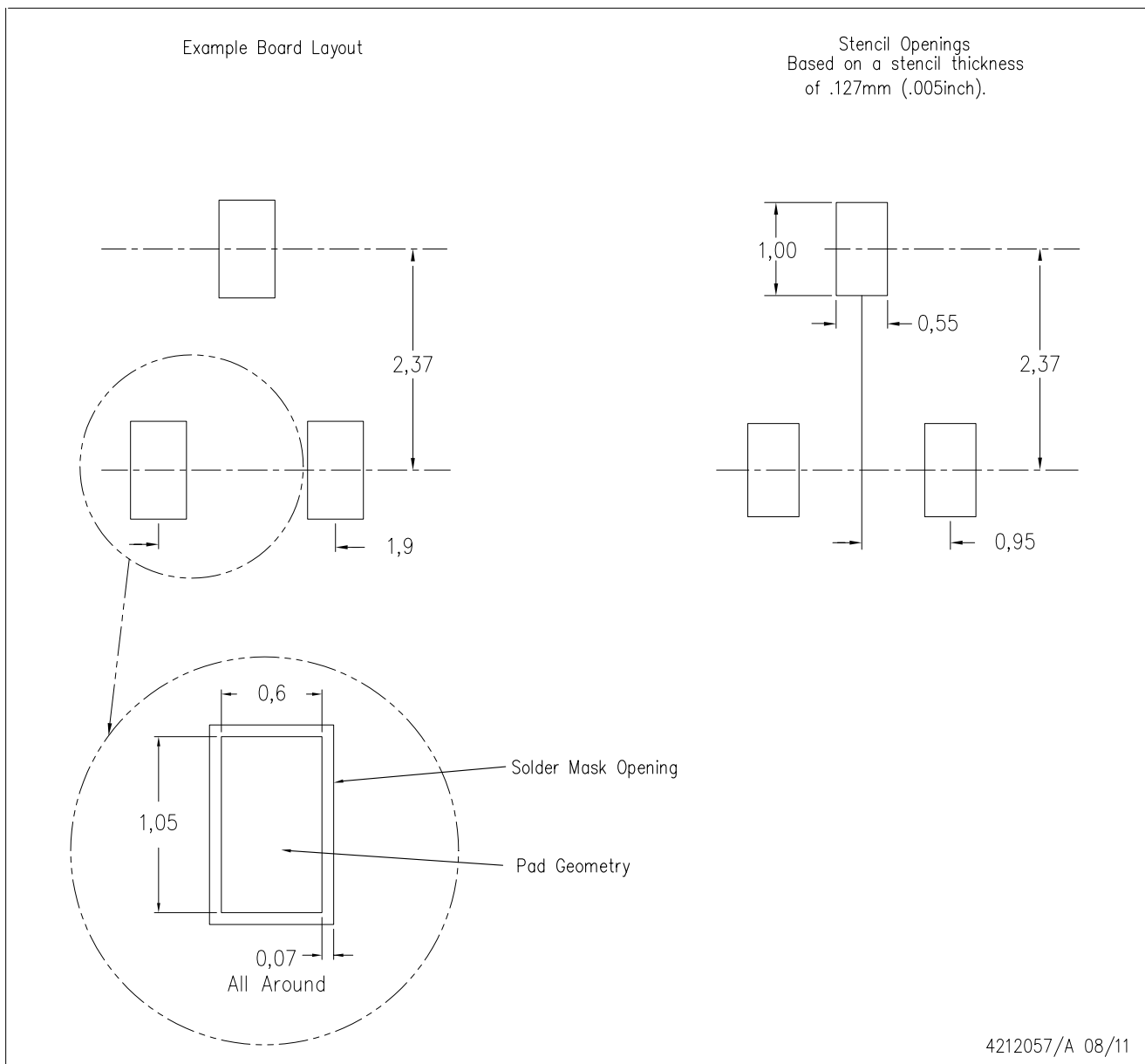

- NOTES:
- A. All linear dimensions are in millimeters.
 - B. This drawing is subject to change without notice.
 - C. Customers should place a note on the circuit board fabrication drawing not to alter the center solder mask defined pad.
 - D. Publication IPC-7351 is recommended for alternate designs.
 - E. Laser cutting apertures with trapezoidal walls and also rounding corners will offer better paste release. Customers should contact their board assembly site for stencil design recommendations. Example stencil design based on a 50% volumetric metal load solder paste. Refer to IPC-7525 for other stencil recommendations.

IMPORTANT NOTICE

Texas Instruments Incorporated and its subsidiaries (TI) reserve the right to make corrections, enhancements, improvements and other changes to its semiconductor products and services per JESD46, latest issue, and to discontinue any product or service per JESD48, latest issue. Buyers should obtain the latest relevant information before placing orders and should verify that such information is current and complete. All semiconductor products (also referred to herein as "components") are sold subject to TI's terms and conditions of sale supplied at the time of order acknowledgment.

TI warrants performance of its components to the specifications applicable at the time of sale, in accordance with the warranty in TI's terms and conditions of sale of semiconductor products. Testing and other quality control techniques are used to the extent TI deems necessary to support this warranty. Except where mandated by applicable law, testing of all parameters of each component is not necessarily performed.

TI assumes no liability for applications assistance or the design of Buyers' products. Buyers are responsible for their products and applications using TI components. To minimize the risks associated with Buyers' products and applications, Buyers should provide adequate design and operating safeguards.

TI does not warrant or represent that any license, either express or implied, is granted under any patent right, copyright, mask work right, or other intellectual property right relating to any combination, machine, or process in which TI components or services are used. Information published by TI regarding third-party products or services does not constitute a license to use such products or services or a warranty or endorsement thereof. Use of such information may require a license from a third party under the patents or other intellectual property of the third party, or a license from TI under the patents or other intellectual property of TI.

Reproduction of significant portions of TI information in TI data books or data sheets is permissible only if reproduction is without alteration and is accompanied by all associated warranties, conditions, limitations, and notices. TI is not responsible or liable for such altered documentation. Information of third parties may be subject to additional restrictions.

Resale of TI components or services with statements different from or beyond the parameters stated by TI for that component or service voids all express and any implied warranties for the associated TI component or service and is an unfair and deceptive business practice. TI is not responsible or liable for any such statements.

Buyer acknowledges and agrees that it is solely responsible for compliance with all legal, regulatory and safety-related requirements concerning its products, and any use of TI components in its applications, notwithstanding any applications-related information or support that may be provided by TI. Buyer represents and agrees that it has all the necessary expertise to create and implement safeguards which anticipate dangerous consequences of failures, monitor failures and their consequences, lessen the likelihood of failures that might cause harm and take appropriate remedial actions. Buyer will fully indemnify TI and its representatives against any damages arising out of the use of any TI components in safety-critical applications.

In some cases, TI components may be promoted specifically to facilitate safety-related applications. With such components, TI's goal is to help enable customers to design and create their own end-product solutions that meet applicable functional safety standards and requirements. Nonetheless, such components are subject to these terms.

No TI components are authorized for use in FDA Class III (or similar life-critical medical equipment) unless authorized officers of the parties have executed a special agreement specifically governing such use.

Only those TI components which TI has specifically designated as military grade or "enhanced plastic" are designed and intended for use in military/aerospace applications or environments. Buyer acknowledges and agrees that any military or aerospace use of TI components which have **not** been so designated is solely at the Buyer's risk, and that Buyer is solely responsible for compliance with all legal and regulatory requirements in connection with such use.

TI has specifically designated certain components as meeting ISO/TS16949 requirements, mainly for automotive use. In any case of use of non-designated products, TI will not be responsible for any failure to meet ISO/TS16949.

Products

Audio	www.ti.com/audio
Amplifiers	amplifier.ti.com
Data Converters	dataconverter.ti.com
DLP® Products	www.dlp.com
DSP	dsp.ti.com
Clocks and Timers	www.ti.com/clocks
Interface	interface.ti.com
Logic	logic.ti.com
Power Mgmt	power.ti.com
Microcontrollers	microcontroller.ti.com
RFID	www.ti-rfid.com
OMAP Applications Processors	www.ti.com/omap
Wireless Connectivity	www.ti.com/wirelessconnectivity

Applications

Automotive and Transportation	www.ti.com/automotive
Communications and Telecom	www.ti.com/communications
Computers and Peripherals	www.ti.com/computers
Consumer Electronics	www.ti.com/consumer-apps
Energy and Lighting	www.ti.com/energy
Industrial	www.ti.com/industrial
Medical	www.ti.com/medical
Security	www.ti.com/security
Space, Avionics and Defense	www.ti.com/space-avionics-defense
Video and Imaging	www.ti.com/video

TI E2E Community

e2e.ti.com