

μP Controlled Battery Charger for 1-Cell Li-ion or 1-Cell to 3-Cell NiCd/NiMH Batteries

DESCRIPTION

Si9731 is a chemistry independent battery charger designed to pulse charge 1-cell to 3-cell NiCd/NiMH or 1-cell Li-ion batteries. Battery charging is accomplished under direct control from the system processor. An internal low $R_{DS(on)}$ MOSFET can be pulsed on and off at varying duty cycle by the system processor to pulse charge the battery at high charge current while minimizing heat dissipation. Provision is also made to trickle charge a discharged battery until the processor so that the processor can take control of the charging process. For charging Li-ion batteries, Si9731 includes a precision voltage reference and an error amplifier for constant voltage (CV) charge mode. The Si9731 is available in lead (Pb)-free TSSOP-16 package and is classified over the industrial temperature range (- 40 °C to + 85 °C).

FEATURES

- Pulse charges 1-cell Li-ion or 1-cell to 3-cell NiCd/NiMH batteries
- Integrated MOSFETs with bi-directional reverse current blocking in "OFF" mode
- PWM controlled fast charging mode
- Low current trickle charge mode
- Pin selectable 4.1 V or 4.2 V charge termination for Li-ion
- Constant voltage (CV) termination for Li-ion
- Input over-voltage detector with automatic shutdown
- External shutdown
- Under 1 μA reverse battery leakage current in shutdown
- Complete isolation from battery to external power supply in shutdown
- Thermal shutdown
- Minimum number of external components
- ESD protection to 4 kV on charger input and battery output
- TSSOP-16 package (1.2 mm maximum height)
- **Halogen-free according to IEC 61249-2-21 definition**
- **Compliant to RoHS directive 2002/95/EC**



RoHS
COMPLIANT
HALOGEN
FREE

APPLICATIONS

- Cellular phone battery charger
- Personal digital assistants

FUNCTIONAL BLOCK DIAGRAM

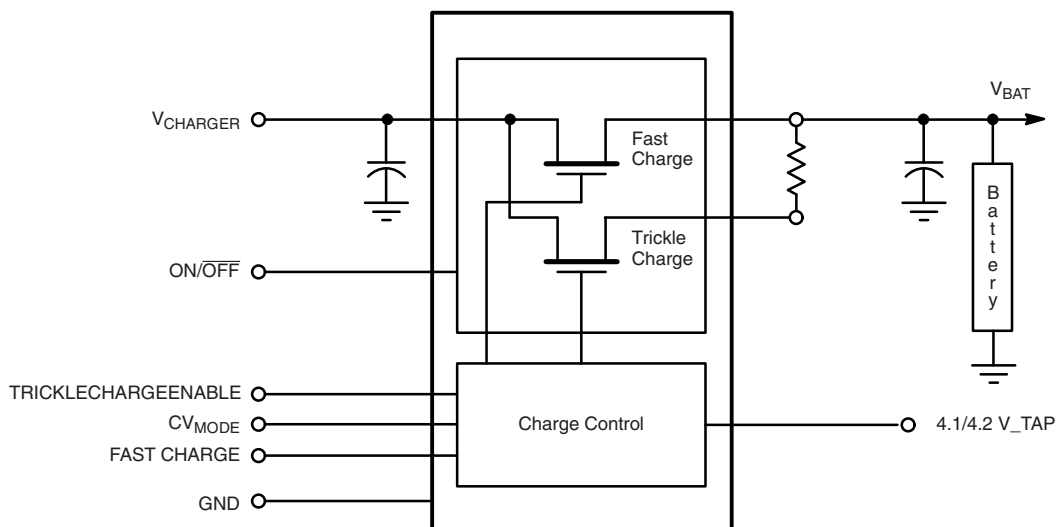

ABSOLUTE MAXIMUM RATINGS			
Parameter	Symbol	Limit	Unit
Voltages Referenced to GND = 0 V			
$V_{\text{CHARGER}}, V_{\text{(CVMODE)}}, V_{\text{(TRICKLECHARGEEN)}}, V_{\text{(MAINCHARGEREN)}}, V_{\text{(ON/OFF)}}, V_{\text{(4.1 V_TAP)}}, V_{\text{(VBAT+)}} , V_{\text{(CHARGERPOWER_ON)}}, V_{\text{(CHARGERPRESENT)}}, V_{\text{(TRICKLE_VBAT)}}$			
$V_{\text{(CHARGERPRESENTIN)}}, V_{\text{(CHARGERPOWER_ONIN)}}$		- 0.3 to 13.5	V
Maximum Input Current ($I_{\text{CHARGER(max)}}$)		1.2	A
Maximum Sink Current CHARGERPOWER_ON and CHARGERPRESENT Pins		5	mA
Storage Temperature		- 65 to 150	°C
Operating Junction Temperature		150	
Power Dissipation (Package) ^a	16-Pin TSSOP (Q Suffix) ^b	1.06	W
Thermal Impedance (θ_{JA})	16-Pin TSSOP	135	°C/W

Notes:

- a. Device Mounted with all leads soldered or welded to PC board.
b. Derate 10 mW/°C above 25 °C.

Stresses beyond those listed under "Absolute Maximum Ratings" may cause permanent damage to the device. These are stress ratings only, and functional operation of the device at these or any other conditions beyond those indicated in the operational sections of the specifications is not implied. Exposure to absolute maximum rating conditions for extended periods may affect device reliability.

RECOMMENDED OPERATING RANGE			
Parameter	Symbol	Limit	Unit
Voltages Referenced to GND = 0 V			
V_{CHARGER}		3.0 to 12	V
Ambient Temperature		- 40 to + 85	°C
V_{REF} Bypass Capacitor		0.1	μF
C_{OUT}		2.2	
C_{IN}		2.2	

See application drawing Figure 1.

SPECIFICATIONS								
Parameter	Symbol	Test Conditions Unless Specified			Min. ^a	Typ. ^b	Max. ^a	Unit
		- 40 °C < T _A < + 85 °C 3.0 V ≤ V _{CHARGER} ≤ 6.5 V, V _{ON/OFF} = 1.5 V						
External Charger Voltage	V _{CHARGER}			3.0		12	V	
Under Voltage Lockout on Charger	V _{UVLO}	Rising Edge of Battery Charger			2.45	2.6		2.75
UVLO Hysteresis	UVLO _{HYST}			70	90	110	mV	
Regulated Output Voltage 4.1 V_TAP to V _{BAT}	V _{TERM+}	V _{CHARGER} = 5.0 V I _{BAT+} = 1 mA MAINCHARGEREN = 5.0 V CVMODE = 5.0 V	- 10 °C < T _A < + 40 °C	4.050	4.1	4.150	V	
Regulated Output Voltage 4.1 V_TAP Open			- 40 °C < T _A < + 85 °C	4.025	4.1	4.150		
			- 10 °C < T _A < + 40 °C	4.150	4.2	4.250		
Regulated Output Voltage 4.1 V_TAP Open			- 40 °C < T _A < + 85 °C	4.125	4.2	4.250		
	Battery Over Voltage Protection	V _{OV}	Rising Edge of V _{BAT+}			4.70		4.95
Battery Over Voltage Hysteresis	V _{OV_HYS}				0.11			
Battery Minimum Operating Voltage	V _{BAT(min)}	Rising Edge, V _{BAT+} Latch			3.12	3.24		3.33
Charger Voltage to Battery Voltage Comparator Offset	V _{OS_CB}	Comparator Offset Voltage, V _{CHARGER} - V _{BAT+}	MAINCHARGEEN-High	- 0.08	- 0.04	- 0.01		
			MAINCHARGEEN-Low	0.01	0.04	0.08		
Charger Voltage to Battery Voltage Comparator Hysteresis					0.07			



SPECIFICATIONS								
Parameter	Symbol	Test Conditions Unless Specified - 40 °C < T _A < + 85 °C 3.0 V ≤ V _{CHARGER} ≤ 6.5 V, V _{ON/OFF} = 1.5 V			Unit			
		Min. ^a	Typ. ^b	Max. ^a				
Quiescent Current (Normal Mode)	I _{IN(VCHARGER Pin) ON-Mode}	1 mA ≤ I _{BAT+} ≤ 600 mA			mA			
Quiescent Current (Shutdown Mode)	I _{IN(VCHARGER Pin) OFF-Mode}	V _{ON/OFF} = 0 V, V _{CHARGER} = 4.5 V			μA			
Feedback Resistor	R _{FB1}	Pin 12 to Pin 14			kΩ			
	R _{FB2} + R _{FB3}	Pin 12 to GND						
Battery Leakage Current	I _{PIN13} + I _{PIN14}	V _{BAT+} = 4.2 V	V _{ON/OFF} = 0 V	- 1	0.1	1	μA	
			V _{CHARGER} = 0 V	- 1	0.1	2		
Q1 ON Resistance	Q1 R _{DS(on)}	V _{CHARGER} = 4.5 V	MAINCHARGEEN ≥ 1.5 V		400	mΩ		
Q2 ON Resistance	Q2 R _{DS(on)}		TRICKLECHARGEEN ≤ 0.4 V		6	10	Ω	
Q5 ON Resistance ^c	Q5 R _{DS(on)}		CVMODE ≥ 1.5 V		6			
Over Voltage Detect Threshold	V _{CHARGER(OVD)}	Rising Edge of Battery Charger			12.0	12.8	13.4	V
Over Voltage Detect Threshold Hysteresis	V _{CHARGER(OVD)_HYS}					0.4		
<u>CHARGERPRESENT</u> and <u>CHARGERPOWER_ON</u>	Output High Leakage Current	I _{OH}	V _{OH} = 6.5 V			0.1	2	μA
	Output Low Voltage	V _{OL}	I _{OL} = 1 mA				0.4	V
<u>CHARGERPRESENTIN</u> , <u>CHARGERPOWER_ONIN</u> , <u>TRICKLECHARGEEN</u> , <u>MAINCHARGEEN</u> or <u>CVMODE</u>	Logic Low Voltage	V _{IL}					0.4	
	Logic High Voltage	V _{IH}	1.5					
	Pull Down Current	I _{P/D}				0.7	10	μA
Thermal Shutdown Temperature ^c	T _{S/D}					130		°C
Thermal Shutdown Hysteresis ^c	T _{HYST}					10		
Shutdown High Voltage Logic Level	V _{ON/OFF(high)}				1.5			V
Shutdown Low Voltage Logic Level	V _{ON/OFF(low)}						0.3	
Shutdown Hysteresis	V _{ON/OFF(hyst)}					100		mV

Notes:

- a. The algebraic convention whereby the most negative value is a minimum and the most positive a maximum, is used in this data sheet.
- b. Typical values are for DESIGN AID ONLY, not guaranteed or subject to production testing.
- c. Guaranteed by design and characterization, not subject to production testing.

PIN CONFIGURATION

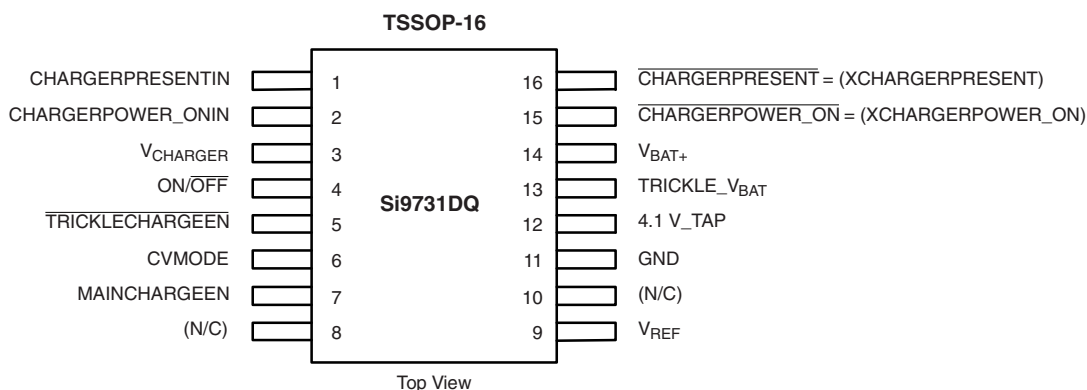

ORDERING INFORMATION

Part Number	Temperature Range	Package
Si9731DQ-T1-E3	- 40 to 85 °C	Tape and Reel

PIN DESCRIPTION

Pin Number	Name	Function
1	CHARGERPRESENTIN	Logic input for $\overline{\text{CHARGERPRESENT}}$ output
2	CHARGERPOWER_ONIN	Logic input for $\overline{\text{CHARGERPOWER_ON}}$ output
3	V_{CHARGER}	External charger
4	ON/ $\overline{\text{OFF}}$	Master shutdown pin. Taking ON/ $\overline{\text{OFF}}$ low shuts down the charger and quiescent current drops to under 1 μA
5	$\overline{\text{TRICKLECHARGEEN}}$	Taking this pin high disables trickle (slow) charging
6	CVMODE	A logic high enables the error amplifier to linearly drive the gate of MOSFET Q1 when MAINCHARGEREN is high.
7	MAINCHARGEEN	An external PWM signal at MAINCHARGEREN pin controls the ON/OFF duty cycle of the Fast Charge MOSFET, Q1.
8, 10	N/C	Do not connect external circuitry to this pin. Circuitry internal to the IC is connected to this pin.
9	V_{REF}	Internal 1.30 V precision bandgap reference voltage. Do not apply loads to this pin.
11	GND	Low impedance system ground
12	4.1 V_TAP	Connect this pin to $V_{\text{BAT+}}$ for 4.1 V charge termination in constant voltage mode
13	TRICKLE_V_BAT	Resistor connected between this pin and V_{BAT} to limit the trickle charge current.
14	$V_{\text{BAT+}}$	Charger output connected to battery's positive terminal
15	$\overline{\text{CHARGERPOWER_ON}}$	Open drain logic output
16	$\overline{\text{CHARGERPRESENT}}$	Open drain logic output

TABLE 1: BATTERY CHARGING CONTROL LOGIC Nominal Voltage Values							
$V_{CHARGER}$	$\overline{TRICKLE}$ CHARGEEN	CVMODE	MAIN CHARGEEN	ON/OFF	Q1^b	Q2	Mode
Not Present	X	X	X	X	OFF	OFF	Not Charging
Not Present OK to Charge ^a	X	X	X	X	OFF	OFF	Not Charging
Over Voltage $V_{CHARGER} > 12.8\text{ V}$	X	X	X	X	OFF	OFF	Not Charging
Present OK to Charge ^a	X	X	X	LOW	OFF	OFF	Not Charging (Shutdown)
	LOW	LOW	LOW	HIGH	OFF	ON	Trickle Charge
	HIGH	LOW	LOW	HIGH	OFF	OFF	Not Charging (Current pulse off during Constant Current Charge)
	LOW	LOW	HIGH	HIGH	ON	OFF	Constant Current Charge (current pulse on)
	HIGH	LOW	HIGH	HIGH	ON	OFF	
	LOW	HIGH	LOW	HIGH	OFF	OFF	Not Charging (Current pulse off during Constant Current Charge with output limited to 4.1 V/4.2 V or end of charge in Li-Ion charging)
	HIGH	HIGH	LOW	HIGH	OFF	OFF	Constant Current Charge (Output Limited to 4.1 V/4.2 V or Constant Voltage Charge)
	LOW	HIGH	HIGH	HIGH	ON	OFF	
HIGH	HIGH	HIGH	HIGH	ON	OFF		

Notes:

a. "OK to Charge" is a flag signal that is enabled by satisfying all the following conditions:

1. Battery voltage is below 5 V
2. Charger voltage is greater than 3 V but below 12.8 V
3. If MAINCHARGEEN = Logic Low, $V_{CHARGER} > V_{BAT} + 40\text{ mV}$,
If MAINCHARGEEN = Logic High, $V_{CHARGER} > V_{BAT} - 40\text{ mV}$
4. ON/OFF pin is at logic high.

b. Q1 drive is determined by the error amplifier during constant voltage mode.

Q1 drive is a combination of Q1 drive (digital) and the output of the error amplifier using the analog adder. The combinations are:

TABLE 2		
Q1 Drive (Digital)	Output of Error Amplifier	Q1 Drive
LOW	LOW	LOW (fully off)
LOW	Intermediate	Intermediate (linear mode)
HIGH	LOW	HIGH (fully on)
HIGH	HIGH	Should Never Happen

TYPICAL CHARACTERISTICS 25 °C, unless otherwise noted

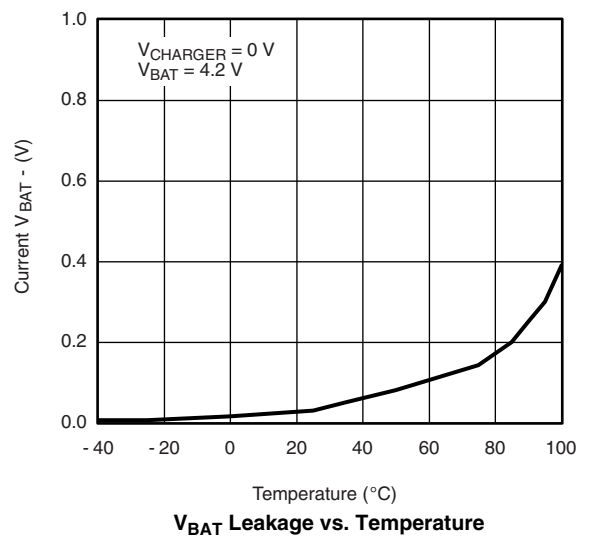
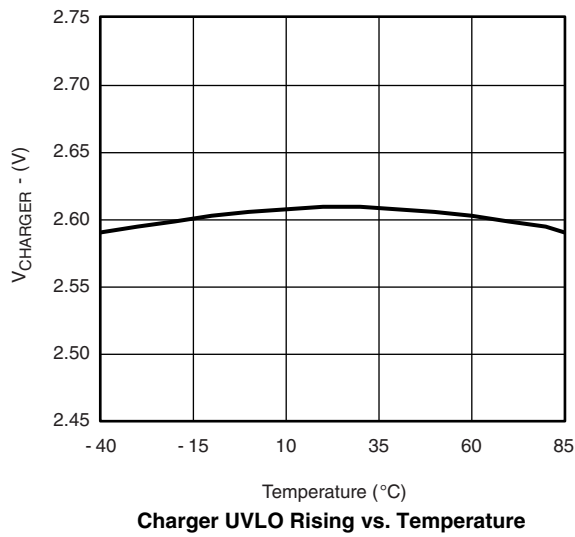
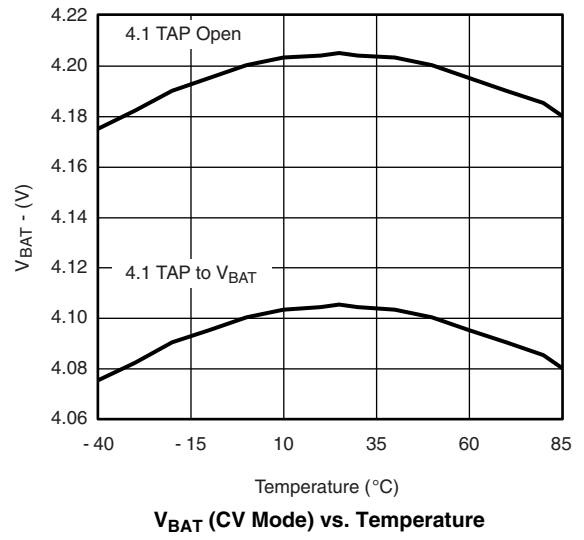
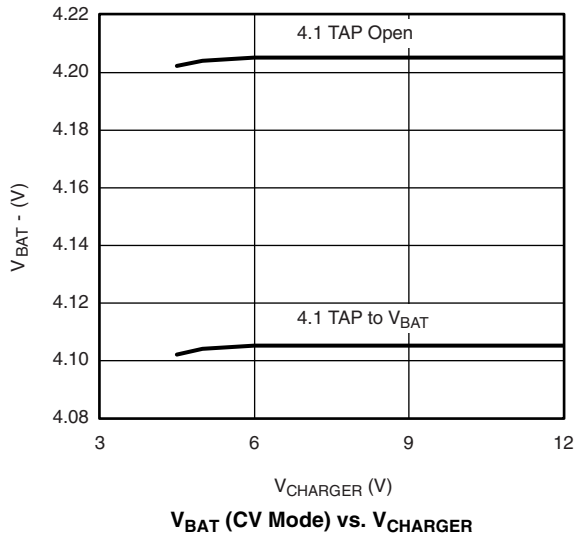

BLOCK DIAGRAM AND TYPICAL APPLICATION CIRCUIT

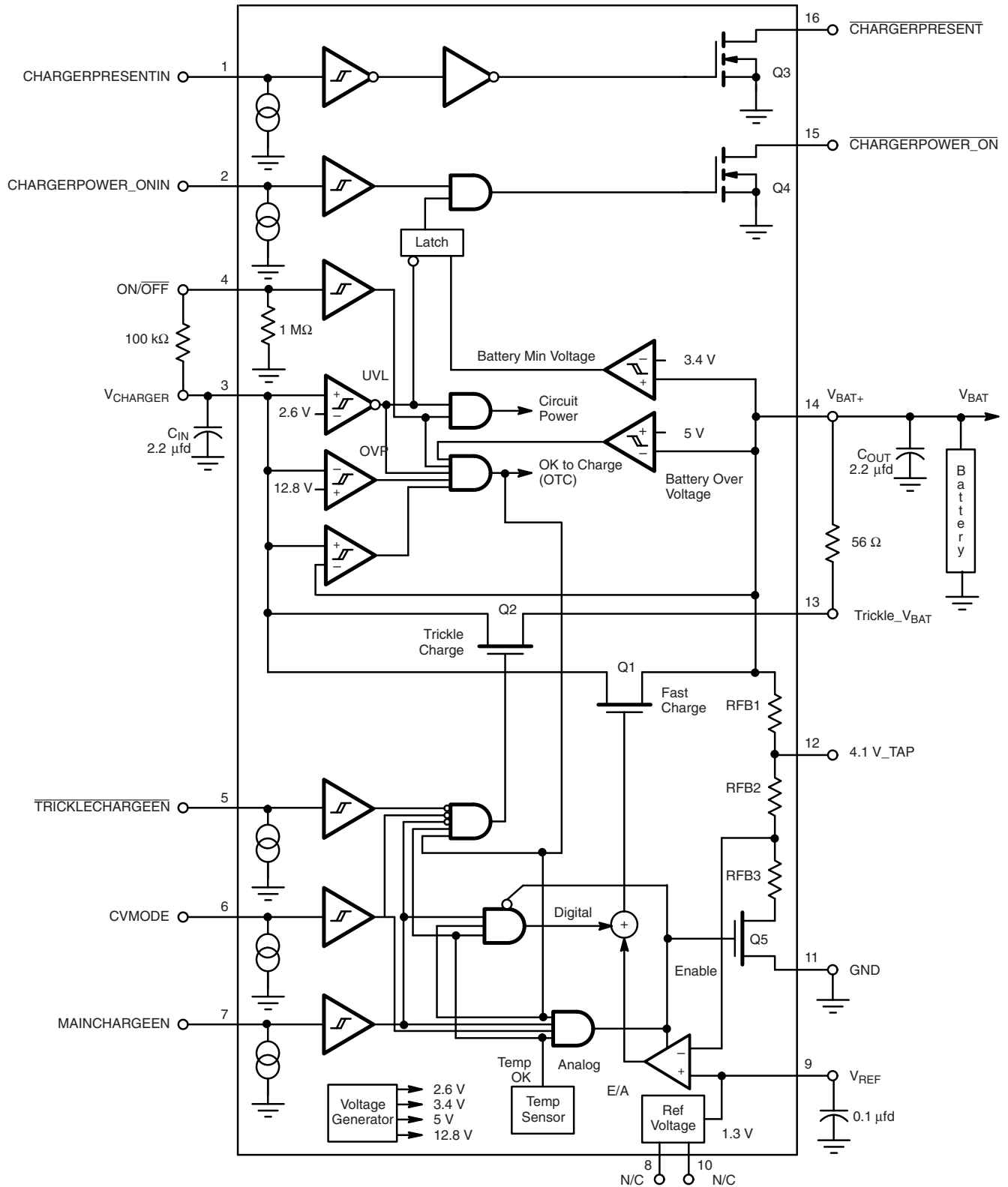

Figure 1.

DETAIL OPERATIONAL DESCRIPTION

Si9731 is a chemistry independent battery charger designed for use with a system processor. For example, Si9731 can be integrated within a cellular phone whereby the fast charge and trickle (slow) charge modes can be software controlled by the DSP. The device is designed to charge 1-cell Li-ion or 1-cell to 3-cell NiCd/NiMH batteries. A regulated or unregulated external dc power source such as a wall adaptor rated at typically 4.5 V to 12 V is connected to Si9731's V_{CHARGER} input pin. Note that a typical low cost wall adaptor is comprised of a transformer, bridge rectifier and a reservoir capacitor. The wall adaptor's output voltage decreases linearly with increase in output current. When Si9731 is fast charging the battery, the wall adaptor's output voltage tracks the battery voltage plus the voltage drop across Q1 (charging current times MOSFET Q1's $R_{\text{DS(on)}}$, see Figure 1). The key features of Si9731 are described below.

Since the under voltage lock out (UVLO) point of Si9731 is 2.6 V (typical), it is essential to keep the charger voltage above this level under all conditions, especially for fast charging of single cell NiCd/NiMH. One simple solution is adding a external resistor between $V_{\text{BAT+}}$ pin and the battery, which creates extra voltage drop to elevate the charger voltage. The value of the resistor is affected by the output V-I characteristic of the ac charger.

Trickle Charge

The charge path is via N-Channel MOSFETs Q1 or Q2 (see applications circuit of Figure 1). Si9731 defaults to trickle (slow) charge mode if the battery voltage is too low to power the main processor. With the main processor unable to drive the $\overline{\text{MAINCHARGEEN}}$ pin as well as the $\overline{\text{TRICKLECHARGEEN}}$ pins, Q1 is turned "OFF" preventing fast charging. Meanwhile N-Channel MOSFET Q2 turns "ON" and establishes a trickle charge path from the external power source V_{CHARGER} to the battery. The trickle charge current is set by an external current limiting resistor, R_{ext} , and is approximately $I_{\text{TRICKLE}} = (V_{\text{CHARGER}} - V_{\text{BAT+}})/R_{\text{ext}}$. Once the battery voltage charges up to minimum battery operating voltage 3.24 V, the internal latch is triggered and the $\overline{\text{CHARGERPOWER_ON}}$ output changes state to wake up the processor. The processor is now able to disable trickle charge mode by taking the $\overline{\text{TRICKLECHARGEEN}}$ pin high while taking control of fast charging via the $\overline{\text{MAINCHARGEEN}}$ pin.

Fast Charge

Fast charging is accomplished by the low "ON" resistance MOSFET, Q1. The application microprocessor is able to "Pulse Charge" the battery via the $\overline{\text{MAINCHARGEREN}}$ control input of Si9731. The processor monitors the battery voltage via the system A/D converter and varies the pulse charging duty cycle accordingly to maintain fast charging. Note that even though charging current may be sufficiently high, pulse charging with short "ON" time and long "OFF" time ensures that heat generation due to thermal heating is reduced.

In the case of NiCd or NiMH batteries, one of several charge termination schemes may be used to terminate charge. For example, the processor may disable fast charging by sensing ΔV or dV/dt at the $V_{\text{BAT+}}$ output or by monitoring the temperature differential ΔT of the battery. Following fast charge, trickle charge may be enabled to "top off" the battery.

When charging a 1-cell Li-ion battery, fast charging will operate in two modes, constant current mode followed by constant voltage mode. In the constant current mode, a discharged Li-ion battery is charged with constant current available from the external dc source. The MOSFET pass transistor (Q1) may be pulsed "ON" and "OFF" at varying duty cycle by the control signal present at the $\overline{\text{MAINCHARGEEN}}$ input pin. Once the battery voltage reaches its termination voltage of 4.1 V or 4.2 V (depending on the connection of the 4.1 V_{TAP}), Si9731 may be placed in the "Constant Voltage" charging mode by taking the $\overline{\text{CVMODE}}$ pin high. Taking $\overline{\text{CVMODE}}$ pin high disables trickle charging and enables the internal battery voltage divider by turning ON Q5. Then the error amplifier will compare divided $V_{\text{BAT+}}$ voltage against an internal precision 1.3 V bandgap reference voltage (see Figure 1). The output of the error amplifier drives the pass transistor Q1 to maintain $V_{\text{BAT+}}$ at the regulated termination voltage. This operation is same as a linear regulator.

True Load Disconnect

Both the fast charge FET (Q1 in Figure 1) and trickle charge FET (Q2 in Figure 1) incorporate a floating body diode. In their "OFF" state both FETs block current bidirectionally. Note that because of the reverse blocking switches, a Schottky diode in series with the external V_{CHARGER} power supply is not required.

DETAIL OPERATIONAL DESCRIPTION

4.1 V_{TAP}

The Si9731's internal feedback resistors are set to provide 4.2 V charge termination at V_{BAT+} output if the 4.1 V_{TAP} is left open circuit. Connecting the 4.1 V_{TAP} to V_{BAT+} configures Si9731 for 4.1 V charge termination at V_{BAT+} . This feature allows Si9731 to accommodate Li-ion batteries requiring 4.1 V or 4.2 V charge termination. Caution: the 4.1 V_{TAP} should not be connected to ground or any other voltage source as this will cause the Si9731 to operate open loop and can result in over charging the battery!

Feedback Disconnect Switch

The Si9731 includes a feedback disconnect switch (Q5 in Figure 1) connected in series with the device's internal feedback resistor string. The 42 k Ω feedback resistor string is connected to ground when both the internal "OK to Charge" signal and the CVMODE pin are at logic high, providing feedback voltage to Si9731's error amplifier. This action helps prevent the Si9731 from discharging the battery.

CHARGERPRESENT and CHARGERPOWERON

CHARGERPRESENT and CHARGERPOWERON are open drain outputs, each requiring an external pull-up resistor. CHARGERPRESENT pin goes low with CHARGERPRESENTIN pin goes high, signaling the processor that a charger has been inserted. CHARGERPOWERON Pin goes low when CHARGERPOWERONIN Pin is high, charger voltage is not in UVLO and the battery voltage has increased to above 3.24 V, turning on the system power supply since the battery has been charged up to minimum operating voltage.

Input Over-Voltage Detector

The external dc source connected to the $V_{CHARGER}$ pin should be at 12 V or less. In the unlikely event that the voltage at $V_{CHARGER}$ pin is at or above 12.8 V (typical), Si9731's internal over voltage detector will turn off MOSFETs Q1, Q2, and Q5 and disable charging.

Thermal Shutdown

Si9731 also includes a thermal protection circuit that suspends charging through Q1 and Q2 when die temperature exceeds 130 °C due to overheating. Once the die temperature cools to below 120 °C, the charging will resume.

Shutdown

Si9731 can be completely turned off by applying 0.4 V or less to the device's ON/OFF pin. In shutdown mode, Si9731 draws less than 1 μ A quiescent current with charger voltage below UVLO, and draws 500 μ A when charger voltage is above UVLO. The device is enabled by applying 1.5 V to 12 V at the ON/OFF pin. In applications where the device will always remain enabled, the ON/OFF pin may be connected to the $V_{CHARGER}$ pin. Si9731's shutdown circuitry includes hysteresis, as such the device will operate properly even if a slow moving signal is applied to the ON/OFF pin. When the device is enabled, the battery voltage sense circuitry draws approximately 25 μ A from V_{BAT} .

OK to Charge (OTC)

Si9731 also includes an internal signal that enables both trickle charge mode and fast charge mode operations, the "OK to Charge" (or OTC) signal. The OTC signal is at logic high if all of the following are satisfied:

1. Battery voltage is below 5 V
2. Charger voltage is greater than 2.6 V but below 12.8 V
3. $V_{CHARGER} > V_{BAT} + 40$ mV when MAINCHARGEEN = Low
 $V_{CHARGER} > V_{BAT} - 40$ mV when MAINCHARGEEN = High
4. ON/OFF pin is at logic high.

In order to charge the battery in any manner, the OTC signal has to be high.

TSSOP: 16-LEAD

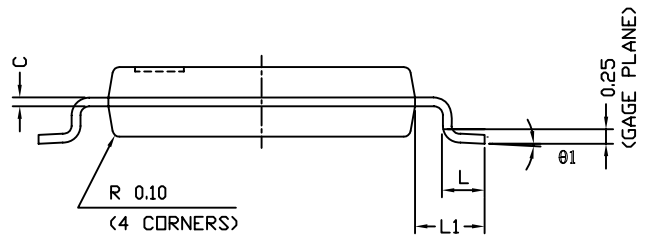
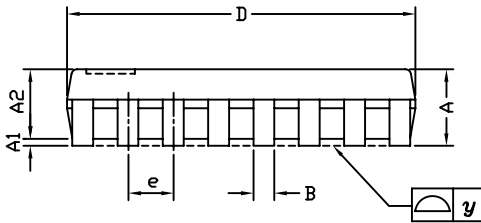
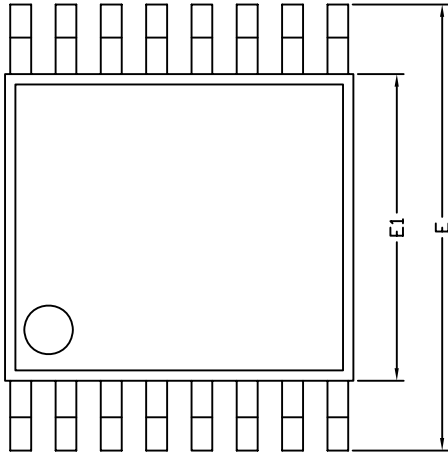

Symbols	DIMENSIONS IN MILLIMETERS		
	Min	Nom	Max
A	-	1.10	1.20
A1	0.05	0.10	0.15
A2	-	1.00	1.05
B	0.22	0.28	0.38
C	-	0.127	-
D	4.90	5.00	5.10
E	6.10	6.40	6.70
E1	4.30	4.40	4.50
e	-	0.65	-
L	0.50	0.60	0.70
L1	0.90	1.00	1.10
y	-	-	0.10
θ1	0°	3°	6°

ECN: S-61920-Rev. D, 23-Oct-06
DWG: 5624



RECOMMENDED MINIMUM PAD FOR TSSOP-16

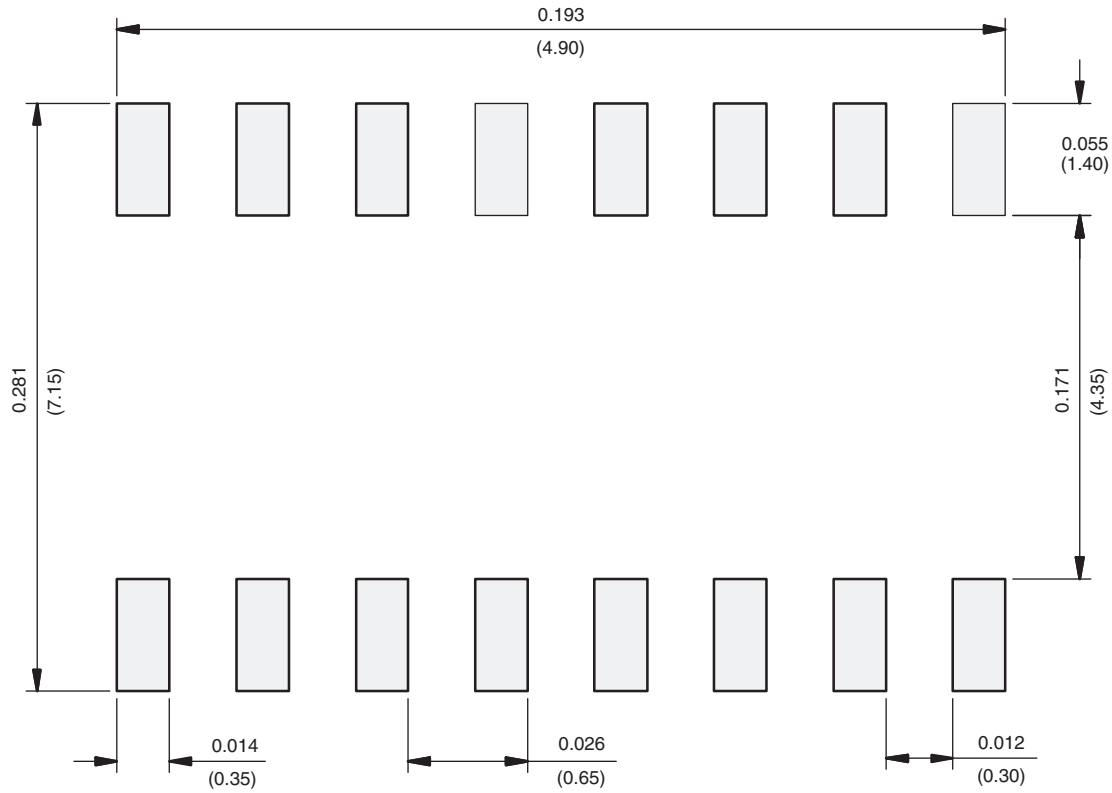

Recommended Minimum Pads
Dimensions in inches (mm)



Disclaimer

ALL PRODUCT, PRODUCT SPECIFICATIONS AND DATA ARE SUBJECT TO CHANGE WITHOUT NOTICE TO IMPROVE RELIABILITY, FUNCTION OR DESIGN OR OTHERWISE.

Vishay Intertechnology, Inc., its affiliates, agents, and employees, and all persons acting on its or their behalf (collectively, "Vishay"), disclaim any and all liability for any errors, inaccuracies or incompleteness contained in any datasheet or in any other disclosure relating to any product.

Vishay makes no warranty, representation or guarantee regarding the suitability of the products for any particular purpose or the continuing production of any product. To the maximum extent permitted by applicable law, Vishay disclaims (i) any and all liability arising out of the application or use of any product, (ii) any and all liability, including without limitation special, consequential or incidental damages, and (iii) any and all implied warranties, including warranties of fitness for particular purpose, non-infringement and merchantability.

Statements regarding the suitability of products for certain types of applications are based on Vishay's knowledge of typical requirements that are often placed on Vishay products in generic applications. Such statements are not binding statements about the suitability of products for a particular application. It is the customer's responsibility to validate that a particular product with the properties described in the product specification is suitable for use in a particular application. Parameters provided in datasheets and/or specifications may vary in different applications and performance may vary over time. All operating parameters, including typical parameters, must be validated for each customer application by the customer's technical experts. Product specifications do not expand or otherwise modify Vishay's terms and conditions of purchase, including but not limited to the warranty expressed therein.

Except as expressly indicated in writing, Vishay products are not designed for use in medical, life-saving, or life-sustaining applications or for any other application in which the failure of the Vishay product could result in personal injury or death. Customers using or selling Vishay products not expressly indicated for use in such applications do so at their own risk. Please contact authorized Vishay personnel to obtain written terms and conditions regarding products designed for such applications.

No license, express or implied, by estoppel or otherwise, to any intellectual property rights is granted by this document or by any conduct of Vishay. Product names and markings noted herein may be trademarks of their respective owners.

Material Category Policy

Vishay Intertechnology, Inc. hereby certifies that all its products that are identified as RoHS-Compliant fulfill the definitions and restrictions defined under Directive 2011/65/EU of The European Parliament and of the Council of June 8, 2011 on the restriction of the use of certain hazardous substances in electrical and electronic equipment (EEE) - recast, unless otherwise specified as non-compliant.

Please note that some Vishay documentation may still make reference to RoHS Directive 2002/95/EC. We confirm that all the products identified as being compliant to Directive 2002/95/EC conform to Directive 2011/65/EU.

Vishay Intertechnology, Inc. hereby certifies that all its products that are identified as Halogen-Free follow Halogen-Free requirements as per JEDEC JS709A standards. Please note that some Vishay documentation may still make reference to the IEC 61249-2-21 definition. We confirm that all the products identified as being compliant to IEC 61249-2-21 conform to JEDEC JS709A standards.