

EMC-OPTIMIZED HIGH SPEED CAN TRANSCEIVER

Check for Samples: [SN65HVD1050A-Q1](#)

FEATURES

- Qualified for Automotive Applications
- Improved Drop-In Replacement for TJA1050
- Meets or Exceeds the Requirements of ISO 11898-2
- GIFT/ICT Compliant
- ESD Protection up to ± 12 kV (Human-Body Model) on Bus Pins
- High Electromagnetic Compliance (EMC)
- Bus-Fault Protection of -27 V to 40 V
- Dominant Time-Out Function
- Thermal Shutdown Protection
- Power-Up/Down Glitch-Free Bus Inputs and Outputs
 - High Input Impedance With Low V_{CC}
 - Monotonic Outputs During Power Cycling

APPLICATIONS

- GMW3122 Dual-Wire CAN Physical Layer
- SAE J2284 High-Speed CAN for Automotive Applications
- SAE J1939 Standard Data Bus Interface
- ISO 11783 Standard Data Bus Interface
- NMEA 2000 Standard Data Bus Interface

DESCRIPTION

The SN65HVD1050A meets or exceeds the specifications of the ISO 11898 standard for use in applications employing a Controller Area Network (CAN). The device is qualified for use in automotive applications.

As a CAN transceiver, this device provides differential transmit capability to the bus and differential receive capability to a CAN controller at signaling rates up to 1 megabit per second (Mbps)⁽¹⁾.

- (1) The signaling rate of a line is the number of voltage transitions that are made per second expressed in the units bps (bits per second).

FUNCTION BLOCK DIAGRAM

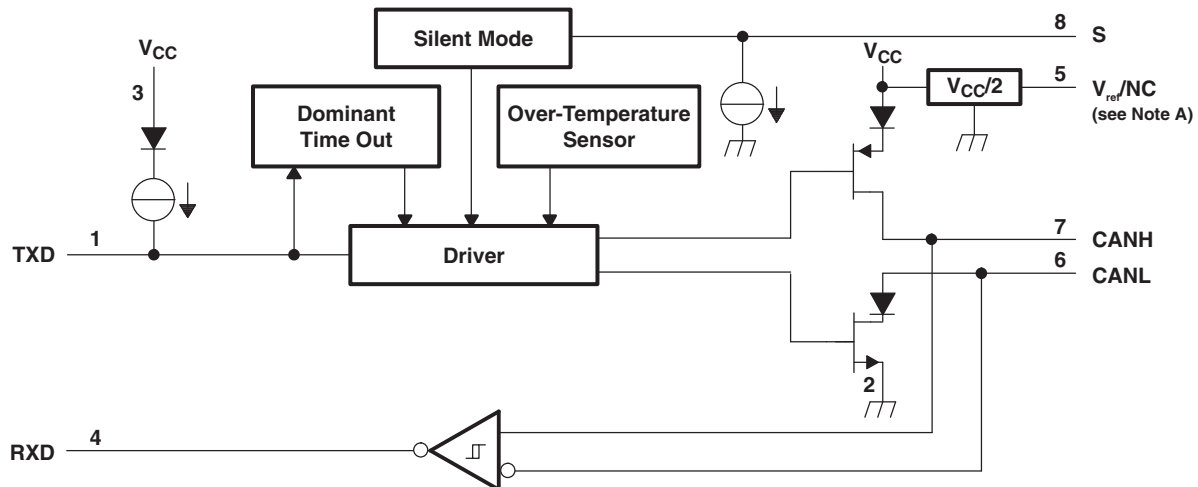

A. V_{ref} on SN65HVD1050A, NC on SN65HVD1050AL



Please be aware that an important notice concerning availability, standard warranty, and use in critical applications of Texas Instruments semiconductor products and disclaimers thereto appears at the end of this data sheet.



This integrated circuit can be damaged by ESD. Texas Instruments recommends that all integrated circuits be handled with appropriate precautions. Failure to observe proper handling and installation procedures can cause damage.

ESD damage can range from subtle performance degradation to complete device failure. Precision integrated circuits may be more susceptible to damage because very small parametric changes could cause the device not to meet its published specifications.

DESCRIPTION (CONTINUED)

Designed for operation in especially harsh environments, the SN65HVD1050A features cross-wire, over-voltage, and loss of ground protection from –27 V to 40 V, over-temperature protection, a –12-V to 12-V common-mode range, and withstands voltage transients according to ISO 7637.

Pin 8 provides for two different modes of operation: high-speed or silent mode. The high-speed mode of operation is selected by connecting S (pin 8) to ground.

If a high logic level is applied to the S pin of the SN65HVD1050A, the device enters a listen-only silent mode during which the driver is switched off while the receiver remains fully functional.

In silent mode, all bus activity is passed by the receiver output to the local protocol controller. When data transmission is required the local protocol controller must transition the device to high speed mode by placing a logic low on the S pin to resume full operation.

A dominant time-out circuit in the SN65HVD1050A prevents the driver from blocking network communication with a hardware or software failure. The time-out circuit is triggered by a falling edge on TXD (pin 1). If no rising edge is seen before the time-out constant of the circuit expires, the driver is disabled. The circuit is then reset by the next rising edge on TXD.

V_{ref} (pin 5) is available as a V_{CC}/2 voltage reference.

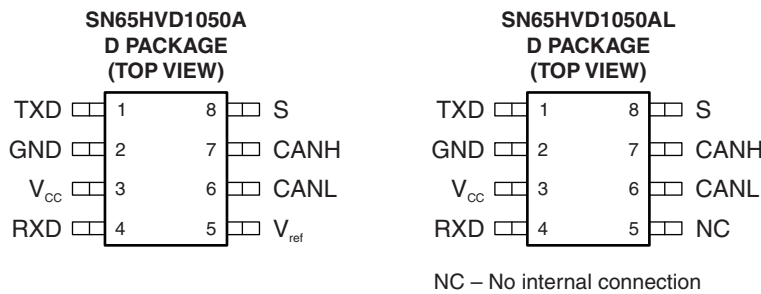

ORDERING INFORMATION⁽¹⁾

T _A	PACKAGE ⁽²⁾		ORDERABLE PART NUMBER	TOP-SIDE MARKING
–40°C to 125°C	SOIC – D	Reel of 2500	SN65HVD1050AQDRQ1	1050AQ
			SN65HVD1050ALQDRQ1	

(1) For the most current package and ordering information, see the Package Option Addendum at the end of this document, or see the TI web site at www.ti.com.

(2) Package drawings, thermal data, and symbolization are available at www.ti.com/packaging.

ABSOLUTE MAXIMUM RATINGS⁽¹⁾

		UNIT
V_{CC}	Supply voltage range ⁽²⁾	–0.3 V to 6 V
	Voltage range at any bus terminal (CANH, CANL, V_{ref})	–27 V to 40 V
I_O	Receiver output current	20 mA
V_I	Voltage input range, ISO 7637 transient pulse ⁽³⁾ (CANH, CANL)	–150 V to 100 V
V_I	Voltage input range (TXD, S)	–0.3 V to 6 V
T_J	Junction temperature range	–40°C to 150°C

- (1) Stresses beyond those listed under "absolute maximum ratings" may cause permanent damage to the device. These are stress ratings only and functional operation of the device at these or any other conditions beyond those indicated under "recommended operating conditions" is not implied. Exposure to absolute-maximum-rated conditions for extended periods may affect device reliability.
- (2) All voltage values, except differential I/O bus voltages, are with respect to network ground terminal.
- (3) Tested in accordance with ISO 7637 test pulses 1, 2, 3a, 3b per IBEE system level test (Pulse 1 = –100 V, Pulse 2 = 100 V, Pulse 3a = –150 V, Pulse 3b = 100 V). If dc may be coupled with ac transients, externally protect the bus pins within the absolute maximum voltage range at any bus terminal. This device has been tested with dc bus shorts to +40V with leading common-mode chokes. If common-mode chokes are used in the system and the bus lines may be shorted to dc, ensure that the choke type and value in combination with the node termination and shorting voltage either will not create inductive flyback outside of voltage maximum specification or use an external transient-suppression circuit to protect the transceiver from the inductive transients.

ELECTROSTATIC DISCHARGE PROTECTION

PARAMETER	TEST CONDITIONS		UNIT
Electrostatic discharge ⁽¹⁾	Human-Body Model ⁽²⁾	CANH and CANL bus pins ⁽³⁾	±12 kV
		V_{ref} pin ⁽⁴⁾	±10 kV
		All pins	±4 kV
	Charged-Device Model ⁽⁵⁾	All pins	±1.5 kV
	Machine Model ⁽⁶⁾		±200 V

- (1) All typical values at 25°C.
- (2) Tested in accordance JEDEC Standard 22, Test Method A114E.
- (3) Test method based upon JEDEC Standard 22 Test Method A114E, CANH and CANL bus pins stressed with respect to each other and GND.
- (4) Test method based upon JEDEC Standard 22 Test Method A114E, V_{ref} pin stressed with respect to GND.
- (5) Tested in accordance JEDEC Standard 22, Test Method C101C.
- (6) Tested in accordance JEDEC Standard 22, Test Method A115A.

RECOMMENDED OPERATING CONDITIONS

			MIN	MAX	UNIT
V_{CC}	Supply voltage		4.75	5.25	V
V_I or V_{IC}	Voltage at any bus terminal (separately or common mode)		–12	12	V
V_{IH}	High-level input voltage	TXD, S	2	5.25	V
V_{IL}	Low-level input voltage	TXD, S	0	0.8	V
V_{ID}	Differential input voltage		–6	6	V
I_{OH}	High-level output current	Driver	–70		mA
		Receiver	–2		
I_{OL}	Low-level output current	Driver		70	mA
		Receiver		2	
T_A	Operating free-air temperature range	See Thermal Characteristics table	–40	125	°C

SUPPLY CURRENT

over recommended operating conditions, $T_A = -40$ to 125°C (unless otherwise noted)

PARAMETER		TEST CONDITIONS	MIN	TYP ⁽¹⁾	MAX	UNIT
I_{CC}	5-V supply current	Silent mode		6	10	mA
		Dominant	$V_I = 0$ V, 60- Ω load, S at 0 V	50	70	
		Recessive	$V_I = V_{CC}$, No load, S at 0 V		6	

- (1) All typical values are at 25°C with a 5-V supply.

DEVICE SWITCHING CHARACTERISTICS

over recommended operating conditions, $T_A = -40$ to 125°C (unless otherwise noted)

PARAMETER		TEST CONDITIONS	MIN	MAX	UNIT
$t_{d(\text{LOOP1})}$	Total loop delay, driver input to receiver output, recessive to dominant	S at 0 V, See Figure 9	90	230	ns
$t_{d(\text{LOOP2})}$	Total loop delay, driver input to receiver output, dominant to recessive	S at 0 V, See Figure 9	90	230	ns

DRIVER ELECTRICAL CHARACTERISTICS

over recommended operating conditions, $T_A = -40$ to 125°C (unless otherwise noted)

PARAMETER		TEST CONDITIONS	MIN	TYP ⁽¹⁾	MAX	UNIT
$V_{O(D)}$	Bus output voltage (dominant)	CANH	2.9	3.4	4.5	V
		CANL				
$V_{O(R)}$	Bus output voltage (recessive)	$V_I = 0$ V, S at 0 V, $R_L = 60\ \Omega$, See Figure 1 and Figure 2	0.8		1.5	
$V_{O(D)}$	Differential output voltage (dominant)	$V_I = 3$ V, S at 0 V, $R_L = 60\ \Omega$, See Figure 1 and Figure 2	2	2.3	3	V
$V_{OD(D)}$	Differential output voltage (dominant)	$V_I = 0$ V, $R_L = 60\ \Omega$, S at 0 V, See Figure 1 , Figure 2 , and Figure 3	1.5		3	V
		$V_I = 0$ V, $R_L = 45\ \Omega$, S at 0 V, See Figure 1 , Figure 2 , and Figure 3	1.4		3	V
$V_{OD(R)}$	Differential output voltage (recessive)	$V_I = 3$ V, S at 0 V, See Figure 1 and Figure 2	-0.012		0.012	V
		$V_I = 3$ V, S at 0 V, No Load	-0.5		0.05	
$V_{OC(ss)}$	Steady state common-mode output voltage	S at 0 V, Figure 8	2	2.3	3	V
$\Delta V_{OC(ss)}$	Change in steady-state common-mode output voltage			30		mV
I_{IH}	High-level input current, TXD input	V_I at V_{CC}	-2		2	μA
I_{IL}	Low-level input current, TXD input	V_I at 0 V	-50		-10	μA
$I_{O(off)}$	Power-off TXD output current	V_{CC} at 0 V, TXD at 5 V			1	
$I_{OS(ss)}$	Short-circuit steady-state output current	$V_{CANH} = -12$ V, CANL open, See Figure 11	-105	-72		mA
		$V_{CANH} = 12$ V, CANL open, See Figure 11		0.36	1	
		$V_{CANL} = -12$ V, CANH open, See Figure 11	-1	-0.5		
		$V_{CANL} = 12$ V, CANH open, See Figure 11		71	105	
C_O	Output capacitance	See receiver input capacitance				

(1) All typical values are at 25°C with a 5-V supply.

DRIVER SWITCHING CHARACTERISTICS

over recommended operating conditions, $T_A = -40$ to 125°C (unless otherwise noted)

PARAMETER		TEST CONDITIONS	MIN	TYP ⁽¹⁾	MAX	UNIT
t_{PLH}	Propagation delay time, low-to-high level output	S at 0 V, See Figure 4	25	65	120	ns
t_{PHL}	Propagation delay time, high-to-low level output	S at 0 V, See Figure 4	25	45	120	ns
t_r	Differential output signal rise time	S at 0 V, See Figure 4		25		ns
t_f	Differential output signal fall time	S at 0 V, See Figure 4		50		ns
t_{en}	Enable time from silent mode to dominant	See Figure 7			1	μs
$t_{(dom)}$	Dominant time out ⁽²⁾	$\downarrow V_I$, See Figure 10	300	450	700	μs

(1) All typical values are at 25°C with a 5-V supply.

(2) The TXD dominant time out ($t_{(dom)}$) will disable the driver of the transceiver once the TXD has been dominant longer than $t_{(dom)}$ which will release the bus lines to recessive preventing a local failure from locking the bus dominant. The driver may only transmit dominant again after TXD has been returned HIGH (recessive). While this protects the bus from local faults locking the bus dominant it will limit the minimum data rate possible. The CAN protocol allows a maximum of eleven successive dominant bits (on TXD) for the worst case where five successive dominant bits are followed immediately by an error frame. This along with the $t_{(dom)}$ minimum will limit the minimum bit rate. The minimum bit rate may be calculated by: Minimum Bit Rate = $11 / t_{(dom)} = 11 \text{ bits} / 300\mu\text{s} = 37 \text{ kbps}$.

RECEIVER ELECTRICAL CHARACTERISTICS

over recommended operating conditions, $T_A = -40$ to 125°C (unless otherwise noted)

PARAMETER		TEST CONDITIONS	MIN	TYP ⁽¹⁾	MAX	UNIT
V_{IT+}	Positive-going input threshold voltage	S at 0 V, See Table 3		800	900	mV
V_{IT-}	Negative-going input threshold voltage	S at 0 V, See Table 3	500	650		mV
V_{hys}	Hysteresis voltage ($V_{IT+} - V_{IT-}$)		100	125		mV
V_{OH}	High-level output voltage	$I_O = -2 \text{ mA}$, See Figure 6	4	4.6		V
V_{OL}	Low-level output voltage	$I_O = 2 \text{ mA}$, See Figure 6		0.2	0.4	V
$I_{I(off)}$	Power-off bus input current	CANH or CANL = 5 V, Other pin at 0 V, V_{CC} at 0 V, TXD at 0 V		165	250	μA
$I_{O(off)}$	Power-off RXD leakage current	V_{CC} at 0 V, RXD at 5 V			20	μA
C_I	Input capacitance to ground (CANH or CANL)	TXD at 3 V, $V_I = 0.4 \sin(4E6\pi t) + 2.5 \text{ V}$		13		pF
C_{ID}	Differential input capacitance	TXD at 3 V, $V_I = 0.4 \sin(4E6\pi t)$		6		pF
R_{ID}	Differential input resistance	TXD at 3 V, S at 0 V	30		80	k Ω
R_{IN}	Input resistance (CANH or CANL)	TXD at 3 V, S at 0 V	15	30	40	k Ω
$R_{I(m)}$	Input resistance matching $[1 - (R_{IN(CANH)} / R_{IN(CANL)})] \times 100\%$	$V_{(CANH)} = V_{(CANL)}$	-3	0	3	%

(1) All typical values are at 25°C with a 5-V supply.

RECEIVER SWITCHING CHARACTERISTICS

over recommended operating conditions, $T_A = -40$ to 125°C (unless otherwise noted)

PARAMETER		TEST CONDITIONS	MIN	TYP ⁽¹⁾	MAX	UNIT
t_{PLH}	Propagation delay time, low-to-high-level output	S at 0 V or V_{CC} , See Figure 6	60	100	130	ns
t_{PHL}	Propagation delay time, high-to-low-level output		45	70	130	ns
t_r	Output signal rise time			8		ns
t_f	Output signal fall time			8		ns

(1) All typical values are at 25°C with a 5-V supply.

S PIN CHARACTERISTICS

over recommended operating conditions, $T_A = -40$ to 125°C (unless otherwise noted)

PARAMETER		TEST CONDITIONS	MIN	TYP ⁽¹⁾	MAX	UNIT
I_{IH}	High level input current	S at 2 V	20	40	70	μA
I_{IL}	Low level input current	S at 0.8 V	5	20	30	μA

(1) All typical values are at 25°C with a 5-V supply.

V_{ref} PIN CHARACTERISTICS⁽¹⁾

over recommended operating conditions, $T_A = -40$ to 125°C (unless otherwise noted)

PARAMETER		TEST CONDITIONS	MIN	TYP ⁽²⁾	MAX	UNIT
V_O	Reference output voltage	$-50 \mu\text{A} < I_O < 50 \mu\text{A}$	$0.4 V_{CC}$	$0.5 V_{CC}$	$0.6 V_{CC}$	V

(1) Available only on SN65HVD1050A, not on SN65HVD1050AL.

(2) All typical values are at 25°C with a 5-V supply.

THERMAL CHARACTERISTICS

over recommended operating conditions, $T_A = -40$ to 125°C (unless otherwise noted)

PARAMETER		TEST CONDITIONS	MIN	TYP	MAX	UNIT
θ_{JA}	Junction-to-air thermal resistance ⁽¹⁾	Low-K thermal resistance ⁽²⁾		211		$^\circ\text{C/W}$
		High-K thermal resistance ⁽²⁾		131		
θ_{JB}	Junction-to-board thermal resistance			53		$^\circ\text{C/W}$
θ_{JC}	Junction-to-case thermal resistance			79		$^\circ\text{C/W}$
P_D	Average power dissipation	$V_{CC} = 5 \text{ V}$, $T_J = 27^\circ\text{C}$, $R_L = 60 \Omega$, S at 0 V, Input to TXD at 500 kHz, 50% duty cycle square wave, CL at RXD = 15 pF		112		mW
		$V_{CC} = 5.5 \text{ V}$, $T_J = 130^\circ\text{C}$, $R_L = 45 \Omega$, S at 0 V, Input to TXD at 500 kHz, 50% duty cycle square wave, CL at RXD = 15 pF			170	
Thermal shutdown temperature				190		$^\circ\text{C}$

(1) The junction temperature (T_J) is calculated using the following $T_J = T_A + (P_D * \theta_{JA})$.

(2) Tested in accordance with the Low-K (EIA/JESD51-3) or High-K (EIA/JESD51-7) thermal metric definitions for leaded surface-mount packages.

FUNCTION TABLES
Table 1. DRIVER⁽¹⁾

INPUTS		OUTPUTS		BUS STATE
TXD	S	CANH	CANL	
L	L or Open	H	L	Dominant
H	X	Z	Z	Recessive
Open	X	Z	Z	Recessive
X	H	Z	Z	Recessive

(1) H = high level, L = low level, X = irrelevant, ? = indeterminate, Z = high impedance

Table 2. RECEIVER⁽¹⁾

DIFFERENTIAL INPUTS $V_{ID} = V(CANH) - V(CANL)$	OUTPUT RXD	BUS STATE
$V_{ID} \geq 0.9\text{ V}$	L	Dominant
$0.5\text{ V} < V_{ID} < 0.9\text{ V}$?	?
$V_{ID} \leq 0.5\text{ V}$	H	Recessive
Open	H	Recessive

(1) H = high level, L = low level, X = irrelevant, ? = indeterminate, Z = high impedance

PARAMETER MEASUREMENT INFORMATION

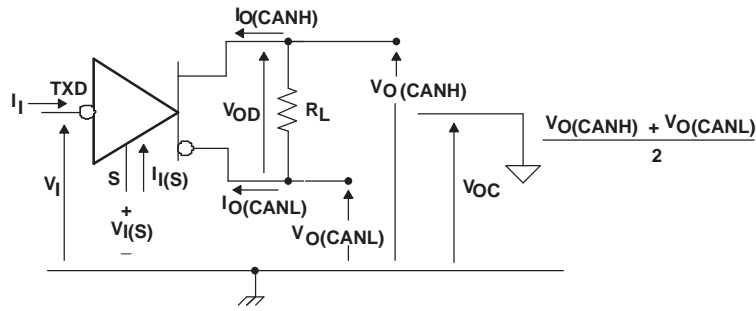

Figure 1. Driver Voltage, Current, and Test Definition

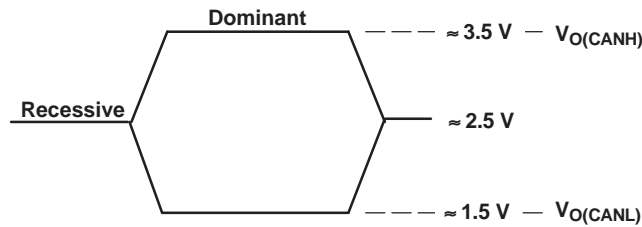

Figure 2. Bus Logic State Voltage Definitions

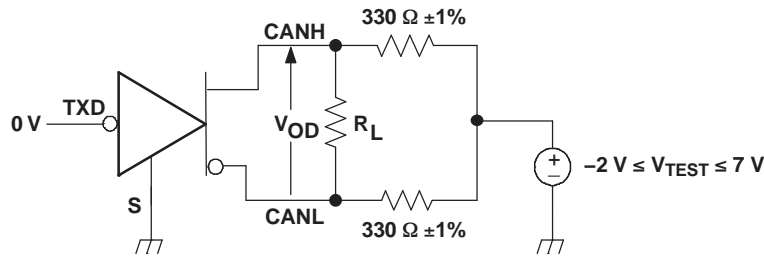

Figure 3. Driver V_{OD} Test Circuit

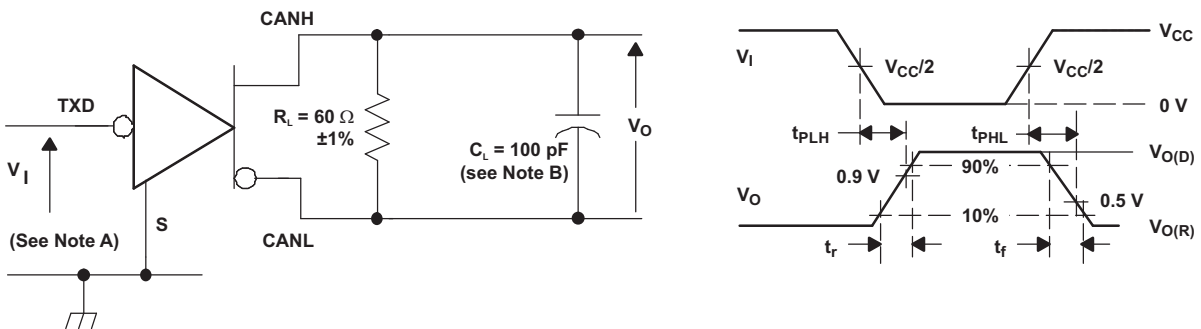

Figure 4. Driver Test Circuit and Voltage Waveforms

PARAMETER MEASUREMENT INFORMATION (continued)

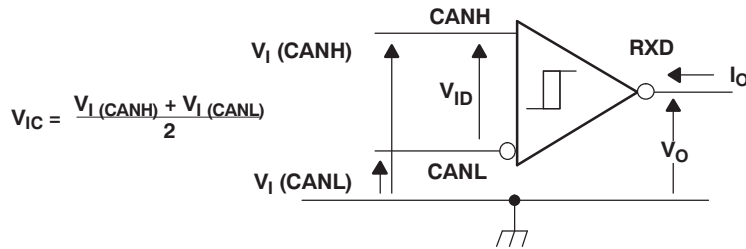
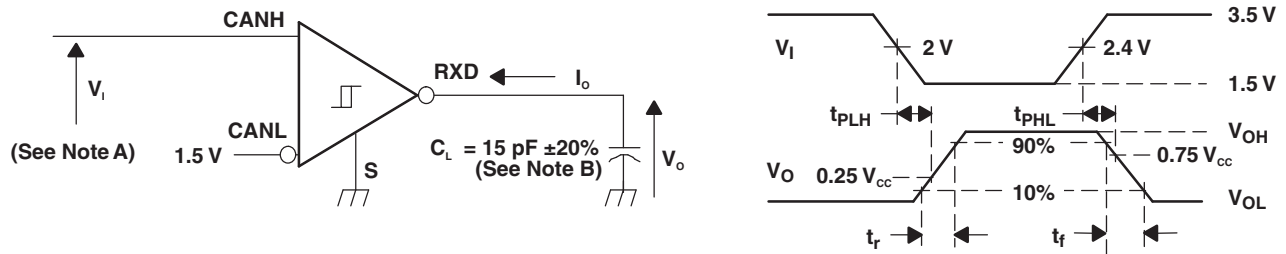

Figure 5. Receiver Voltage and Current Definitions



- A. The input pulse is supplied by a generator having the following characteristics: PRR ≤ 125 kHz, 50% duty cycle, $t_r \leq 6$ ns, $t_f \leq 6$ ns, $Z_0 = 50 \Omega$.
- B. C_L includes instrumentation and fixture capacitance within ±20%.

Figure 6. Receiver Test Circuit and Voltage Waveforms

Table 3. Differential Input Voltage Threshold Test

INPUT			OUTPUT	
V_{CANH}	V_{CANL}	$ V_{ID} $	R	
-11.1 V	-12 V	900 mV	L	V_{OL}
12 V	11.1 V	900 mV	L	
-6 V	-12 V	6 V	L	
12 V	6 V	6 V	L	
-11.5 V	-12 V	500 mV	H	V_{OH}
12 V	11.5 V	500 mV	H	
-12 V	-6 V	6 V	H	
6 V	12 V	6 V	H	
Open	Open	X	H	

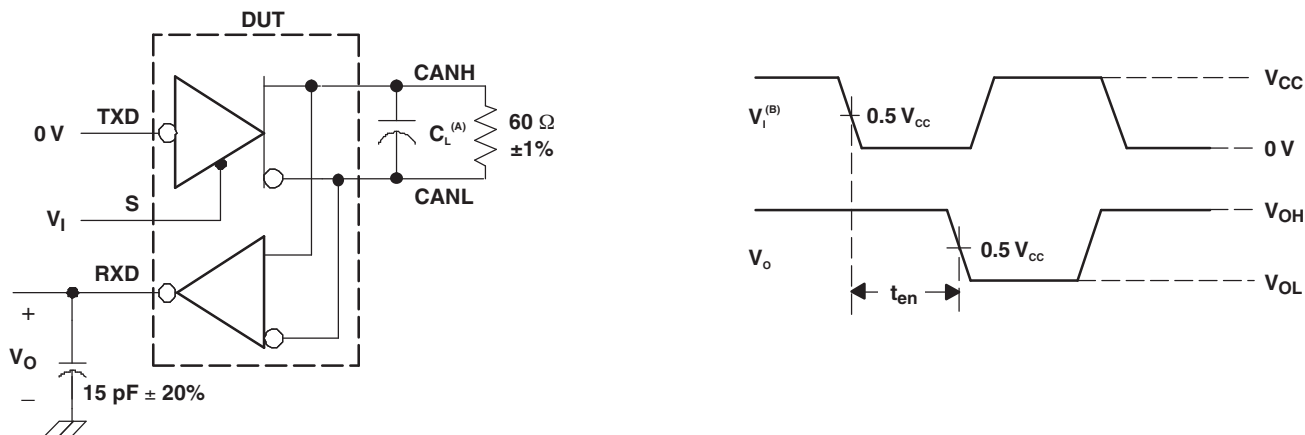

- A. $C_L = 100 \text{ pF}$ and includes instrumentation and fixture capacitance within $\pm 20\%$.
- B. All V_i input pulses are supplied by a generator having the following characteristics: t_r or $t_f \leq 6 \text{ ns}$, pulse repetition rate (PRR) = 125 kHz, 50% duty cycle.

Figure 7. t_{en} Test Circuit and Waveforms

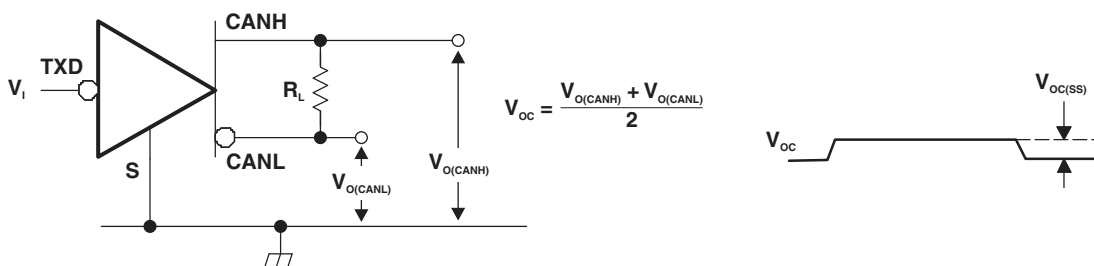

NOTE: All V_i input pulses are from 0 V to V_{CC} and supplied by a generator having the following characteristics: t_r or $t_f \leq 6 \text{ ns}$, pulse repetition rate (PRR) = 125 kHz, 50% duty cycle.

Figure 8. Common-Mode Output Voltage Test and Waveforms

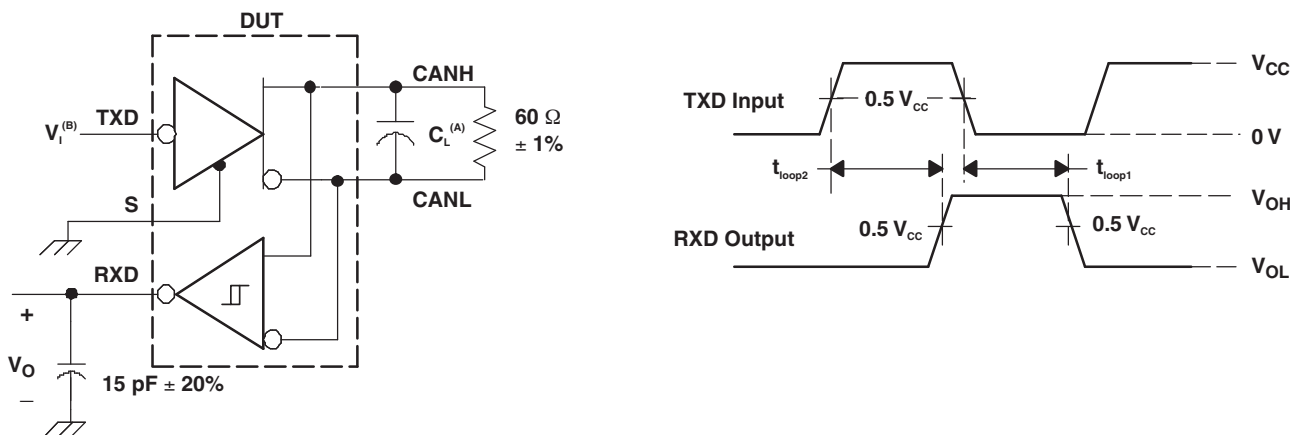

- A. $C_L = 100 \text{ pF}$ and includes instrumentation and fixture capacitance within $\pm 20\%$.
- B. All V_i input pulses are from 0 V to V_{CC} and supplied by a generator having the following characteristics: t_r or $t_f \leq 6 \text{ ns}$, pulse repetition rate (PRR) = 125 kHz, 50% duty cycle.

Figure 9. $t_{(LOOP)}$ Test Circuit and Waveforms

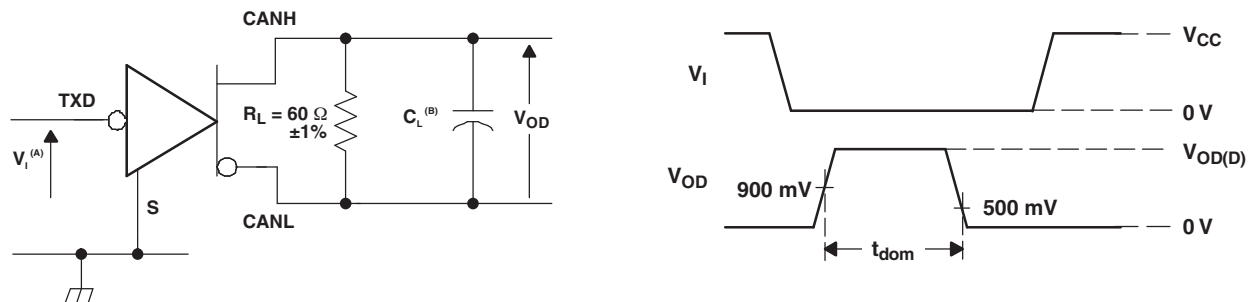

- A. All V_1 input pulses are from 0 V to V_{CC} and supplied by a generator having the following characteristics: t_r or $t_f \leq 6$ ns, pulse repetition rate (PRR) = 500 Hz, 50% duty cycle.
- B. $C_L = 100$ pF includes instrumentation and fixture capacitance within $\pm 20\%$.

Figure 10. Dominant Time-Out Test Circuit and Waveforms

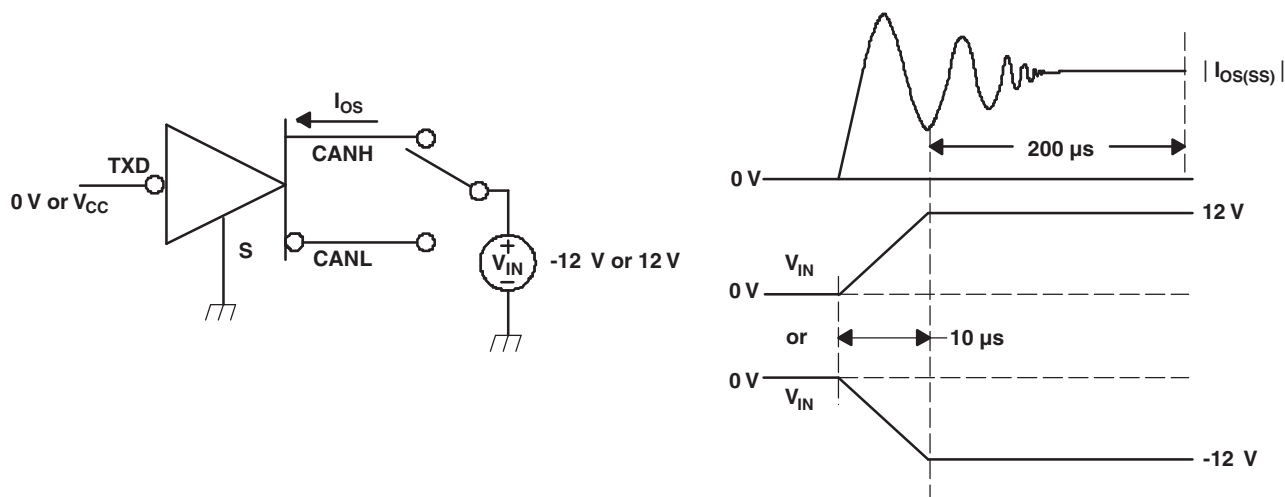

Figure 11. Driver Short-Circuit Current Test and Waveforms

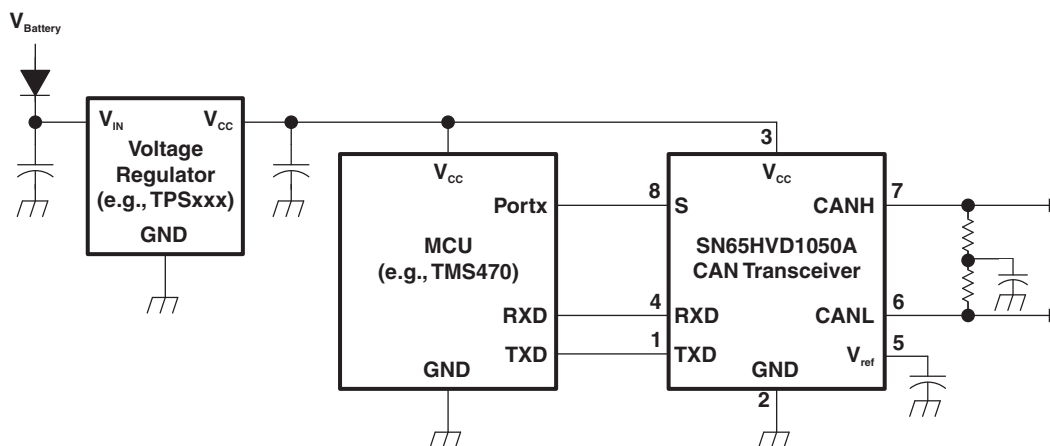
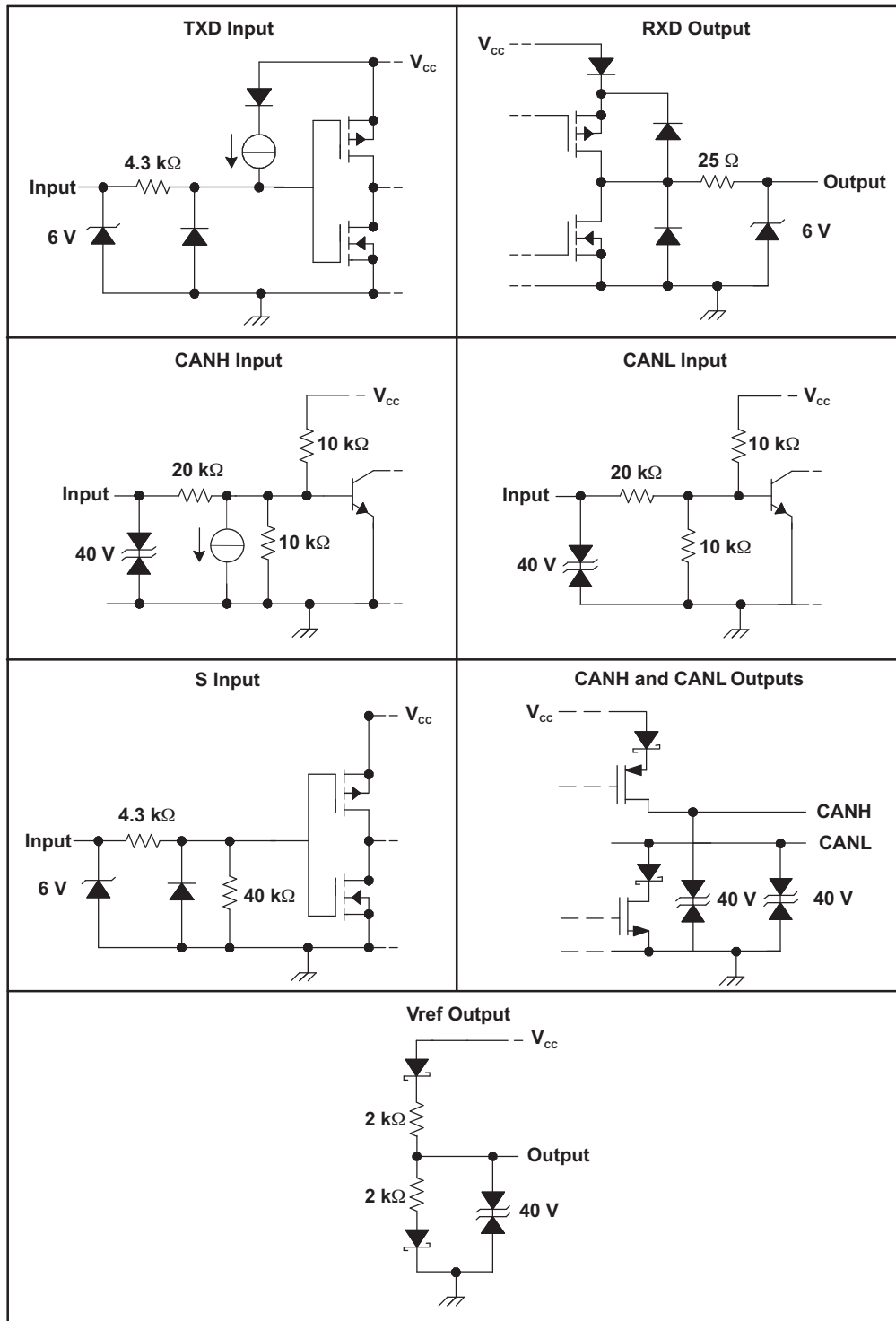

Figure 12. Typical Application

Equivalent Input and Output Schematic Diagrams



PACKAGING INFORMATION

Orderable Device	Status (1)	Package Type	Package Drawing	Pins	Package Qty	Eco Plan (2)	Lead/Ball Finish	MSL Peak Temp (3)	Op Temp (°C)	Top-Side Markings (4)	Samples
SN65HVD1050AQDRQ1	ACTIVE	SOIC	D	8	2500	Green (RoHS & no Sb/Br)	CU NIPDAU	Level-1-260C-UNLIM	-40 to 125	1050AQ	Samples

(1) The marketing status values are defined as follows:

ACTIVE: Product device recommended for new designs.

LIFEBUY: TI has announced that the device will be discontinued, and a lifetime-buy period is in effect.

NRND: Not recommended for new designs. Device is in production to support existing customers, but TI does not recommend using this part in a new design.

PREVIEW: Device has been announced but is not in production. Samples may or may not be available.

OBSOLETE: TI has discontinued the production of the device.

(2) Eco Plan - The planned eco-friendly classification: Pb-Free (RoHS), Pb-Free (RoHS Exempt), or Green (RoHS & no Sb/Br) - please check <http://www.ti.com/productcontent> for the latest availability information and additional product content details.

TBD: The Pb-Free/Green conversion plan has not been defined.

Pb-Free (RoHS): TI's terms "Lead-Free" or "Pb-Free" mean semiconductor products that are compatible with the current RoHS requirements for all 6 substances, including the requirement that lead not exceed 0.1% by weight in homogeneous materials. Where designed to be soldered at high temperatures, TI Pb-Free products are suitable for use in specified lead-free processes.

Pb-Free (RoHS Exempt): This component has a RoHS exemption for either 1) lead-based flip-chip solder bumps used between the die and package, or 2) lead-based die adhesive used between the die and leadframe. The component is otherwise considered Pb-Free (RoHS compatible) as defined above.

Green (RoHS & no Sb/Br): TI defines "Green" to mean Pb-Free (RoHS compatible), and free of Bromine (Br) and Antimony (Sb) based flame retardants (Br or Sb do not exceed 0.1% by weight in homogeneous material)

(3) MSL, Peak Temp. -- The Moisture Sensitivity Level rating according to the JEDEC industry standard classifications, and peak solder temperature.

(4) Multiple Top-Side Markings will be inside parentheses. Only one Top-Side Marking contained in parentheses and separated by a "~" will appear on a device. If a line is indented then it is a continuation of the previous line and the two combined represent the entire Top-Side Marking for that device.

Important Information and Disclaimer: The information provided on this page represents TI's knowledge and belief as of the date that it is provided. TI bases its knowledge and belief on information provided by third parties, and makes no representation or warranty as to the accuracy of such information. Efforts are underway to better integrate information from third parties. TI has taken and continues to take reasonable steps to provide representative and accurate information but may not have conducted destructive testing or chemical analysis on incoming materials and chemicals. TI and TI suppliers consider certain information to be proprietary, and thus CAS numbers and other limited information may not be available for release.

In no event shall TI's liability arising out of such information exceed the total purchase price of the TI part(s) at issue in this document sold by TI to Customer on an annual basis.

TAPE AND REEL INFORMATION



QUADRANT ASSIGNMENTS FOR PIN 1 ORIENTATION IN TAPE



*All dimensions are nominal

Device	Package Type	Package Drawing	Pins	SPQ	Reel Diameter (mm)	Reel Width W1 (mm)	A0 (mm)	B0 (mm)	K0 (mm)	P1 (mm)	W (mm)	Pin1 Quadrant
SN65HVD1050AQDRQ1	SOIC	D	8	2500	330.0	12.4	6.4	5.2	2.1	8.0	12.0	Q1
SN65HVD1050AQDRQ1	SOIC	D	8	2500	330.0	12.4	6.4	5.2	2.1	8.0	12.0	Q1

TAPE AND REEL BOX DIMENSIONS



*All dimensions are nominal

Device	Package Type	Package Drawing	Pins	SPQ	Length (mm)	Width (mm)	Height (mm)
SN65HVD1050AQDRQ1	SOIC	D	8	2500	367.0	367.0	35.0
SN65HVD1050AQDRQ1	SOIC	D	8	2500	367.0	367.0	35.0

D (R-PDSO-G8)

PLASTIC SMALL OUTLINE

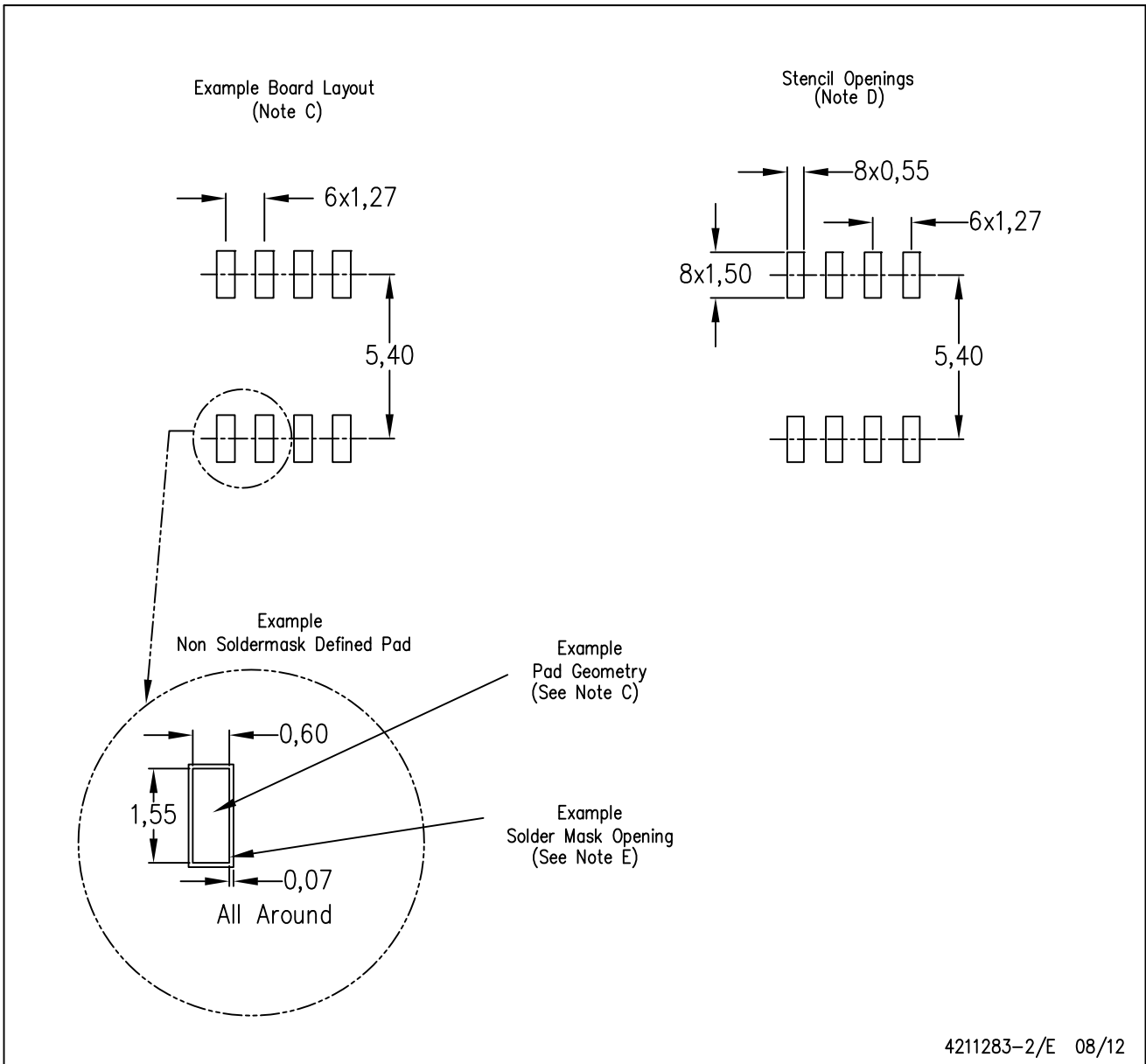

4211283-2/E 08/12

- NOTES:
- A. All linear dimensions are in millimeters.
 - B. This drawing is subject to change without notice.
 - C. Publication IPC-7351 is recommended for alternate designs.
 - D. Laser cutting apertures with trapezoidal walls and also rounding corners will offer better paste release. Customers should contact their board assembly site for stencil design recommendations. Refer to IPC-7525 for other stencil recommendations.
 - E. Customers should contact their board fabrication site for solder mask tolerances between and around signal pads.

IMPORTANT NOTICE

Texas Instruments Incorporated and its subsidiaries (TI) reserve the right to make corrections, enhancements, improvements and other changes to its semiconductor products and services per JESD46, latest issue, and to discontinue any product or service per JESD48, latest issue. Buyers should obtain the latest relevant information before placing orders and should verify that such information is current and complete. All semiconductor products (also referred to herein as "components") are sold subject to TI's terms and conditions of sale supplied at the time of order acknowledgment.

TI warrants performance of its components to the specifications applicable at the time of sale, in accordance with the warranty in TI's terms and conditions of sale of semiconductor products. Testing and other quality control techniques are used to the extent TI deems necessary to support this warranty. Except where mandated by applicable law, testing of all parameters of each component is not necessarily performed.

TI assumes no liability for applications assistance or the design of Buyers' products. Buyers are responsible for their products and applications using TI components. To minimize the risks associated with Buyers' products and applications, Buyers should provide adequate design and operating safeguards.

TI does not warrant or represent that any license, either express or implied, is granted under any patent right, copyright, mask work right, or other intellectual property right relating to any combination, machine, or process in which TI components or services are used. Information published by TI regarding third-party products or services does not constitute a license to use such products or services or a warranty or endorsement thereof. Use of such information may require a license from a third party under the patents or other intellectual property of the third party, or a license from TI under the patents or other intellectual property of TI.

Reproduction of significant portions of TI information in TI data books or data sheets is permissible only if reproduction is without alteration and is accompanied by all associated warranties, conditions, limitations, and notices. TI is not responsible or liable for such altered documentation. Information of third parties may be subject to additional restrictions.

Resale of TI components or services with statements different from or beyond the parameters stated by TI for that component or service voids all express and any implied warranties for the associated TI component or service and is an unfair and deceptive business practice. TI is not responsible or liable for any such statements.

Buyer acknowledges and agrees that it is solely responsible for compliance with all legal, regulatory and safety-related requirements concerning its products, and any use of TI components in its applications, notwithstanding any applications-related information or support that may be provided by TI. Buyer represents and agrees that it has all the necessary expertise to create and implement safeguards which anticipate dangerous consequences of failures, monitor failures and their consequences, lessen the likelihood of failures that might cause harm and take appropriate remedial actions. Buyer will fully indemnify TI and its representatives against any damages arising out of the use of any TI components in safety-critical applications.

In some cases, TI components may be promoted specifically to facilitate safety-related applications. With such components, TI's goal is to help enable customers to design and create their own end-product solutions that meet applicable functional safety standards and requirements. Nonetheless, such components are subject to these terms.

No TI components are authorized for use in FDA Class III (or similar life-critical medical equipment) unless authorized officers of the parties have executed a special agreement specifically governing such use.

Only those TI components which TI has specifically designated as military grade or "enhanced plastic" are designed and intended for use in military/aerospace applications or environments. Buyer acknowledges and agrees that any military or aerospace use of TI components which have **not** been so designated is solely at the Buyer's risk, and that Buyer is solely responsible for compliance with all legal and regulatory requirements in connection with such use.

TI has specifically designated certain components as meeting ISO/TS16949 requirements, mainly for automotive use. In any case of use of non-designated products, TI will not be responsible for any failure to meet ISO/TS16949.

Products

Audio	www.ti.com/audio
Amplifiers	amplifier.ti.com
Data Converters	dataconverter.ti.com
DLP® Products	www.dlp.com
DSP	dsp.ti.com
Clocks and Timers	www.ti.com/clocks
Interface	interface.ti.com
Logic	logic.ti.com
Power Mgmt	power.ti.com
Microcontrollers	microcontroller.ti.com
RFID	www.ti-rfid.com
OMAP Applications Processors	www.ti.com/omap
Wireless Connectivity	www.ti.com/wirelessconnectivity

Applications

Automotive and Transportation	www.ti.com/automotive
Communications and Telecom	www.ti.com/communications
Computers and Peripherals	www.ti.com/computers
Consumer Electronics	www.ti.com/consumer-apps
Energy and Lighting	www.ti.com/energy
Industrial	www.ti.com/industrial
Medical	www.ti.com/medical
Security	www.ti.com/security
Space, Avionics and Defense	www.ti.com/space-avionics-defense
Video and Imaging	www.ti.com/video

TI E2E Community

e2e.ti.com