



## HIGH OUTPUT FULL-DUPLEX RS-485 DRIVERS AND RECEIVERS

Check for Samples :[SN65HVD50-SN65HVD55](#)

### FEATURES

- 1/8 Unit-Load Option Available (Up to 256 Nodes on the Bus)
- Bus-Pin ESD Protection Exceeds 15 kV HBM
- Optional Driver Output Transition Times for Signaling Rates<sup>(1)</sup> of 1 Mbps, 5 Mbps and 25 Mbps
- Low-Current Standby Mode < 1  $\mu$ A
- Glitch-Free Power-Up and Power-Down Bus I/Os
- Bus Idle, Open, and Short Circuit Failsafe
- Designed for RS-422 and RS485 Networks
- 3.3-V Devices Available, SN65HVD30-35

<sup>(1)</sup> The signaling rate of a line is the number of voltage transitions that are made per second expressed in the units bps (bits per second).

### APPLICATIONS

- Utility Meters
- Chassis-to-Chassis Interconnects
- DTE/DCE Interfaces
- Industrial, Process, and Building Automation
- Point-of-Sale (POS) Terminals and Networks

### DESCRIPTION

The SN65HVD5X devices are 3-state differential line drivers and differential-input line receivers that operate with a 5-V power supply. Each driver and receiver has separate input and output pins for full-duplex bus communication designs. They are designed for balanced transmission lines and interoperability with ANSI TIA/EIA-485A, TIA/EIA-422-B, ITU-T v.11 and ISO 8482:1993 standard-compliant devices.

The SN65HVD50, SN65HVD51, and SN65HVD52 are fully enabled with no external enabling pins.

The SN65HVD53, SN65HVD54, and SN65HVD55 have active-high driver enables and active-low receiver enables. A low, less than 1  $\mu$ A, standby current is achieved by disabling both the driver and receiver.

All devices are characterized for operation from  $-40^{\circ}\text{C}$  to  $85^{\circ}\text{C}$ .

The high output feature of the SN65HVD5x provides more noise margin than the typical RS-485 drivers. The extra noise margin makes applications in long cable and harsh noise environments possible.

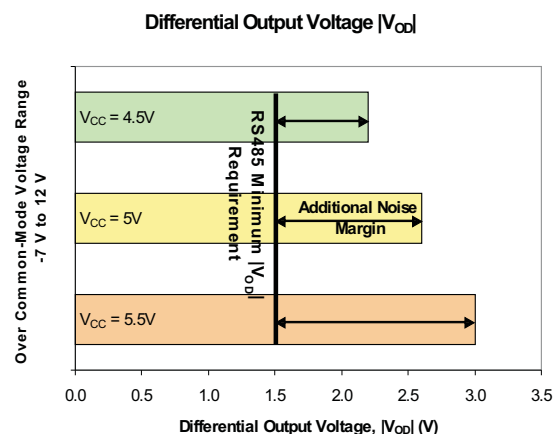

Please be aware that an important notice concerning availability, standard warranty, and use in critical applications of Texas Instruments semiconductor products and disclaimers thereto appears at the end of this data sheet.

# SN65HVD50-SN65HVD55

SLLS666E – SEPTEMBER 2005 – REVISED OCTOBER 2009

[www.ti.com](http://www.ti.com)

This integrated circuit can be damaged by ESD. Texas Instruments recommends that all integrated circuits be handled with appropriate precautions. Failure to observe proper handling and installation procedures can cause damage.

ESD damage can range from subtle performance degradation to complete device failure. Precision integrated circuits may be more susceptible to damage because very small parametric changes could cause the device not to meet its published specifications.

**SN65HVD50, SN65HVD51, SN65HVD52**
**SN65HVD53, SN65HVD54, SN65HVD55**

D PACKAGE (TOP VIEW)

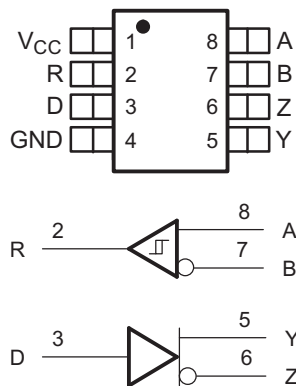

D PACKAGE (TOP VIEW)

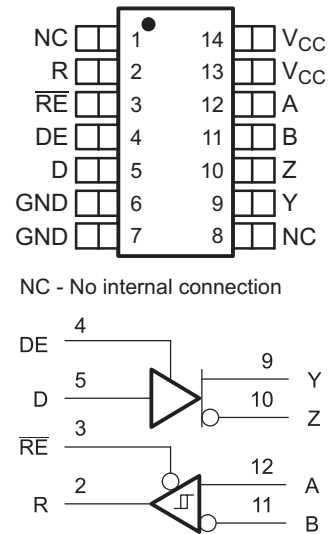

NC - No internal connection

## AVAILABLE OPTIONS

SIGNALING RATE	UNIT LOADS	ENABLES	BASE PART NUMBER	SOIC MARKING
25 Mbps	1/2	No	SN65HVD50	65HVD50
5 Mbps	1/8	No	SN65HVD51	65HVD51
1 Mbps	1/8	No	SN65HVD52	65HVD52
25 Mbps	1/2	Yes	SN65HVD53	65HVD53
5 Mbps	1/8	Yes	SN65HVD54	65HVD54
1 Mbps	1/8	Yes	SN65HVD55	65HVD55

## ABSOLUTE MAXIMUM RATINGS

 over operating free-air temperature range (unless otherwise noted)<sup>(1) (2)</sup>

		UNIT
$V_{CC}$	Supply voltage range	-0.3 V to 6 V
$V_{(A)}, V_{(B)}, V_{(Y)}, V_{(Z)}$	Voltage range at any bus terminal (A, B, Y, Z)	-9 V to 14 V
$V_{(TRANS)}$	Voltage input, transient pulse through 100 $\Omega$ . See Figure 12 (A, B, Y, Z) <sup>(3)</sup>	-50 to 50 V
$V_I$	Voltage input range (D, DE, $\overline{RE}$ )	-0.5 V to 7 V
$P_{D(cont)}$	Continuous total power dissipation	Internally limited <sup>(4)</sup>
$I_O$	Output current (receiver output only, R)	11 mA

- Stresses beyond those listed under absolute maximum ratings may cause permanent damage to the device. These are stress ratings only, and functional operation of the device at these or any other conditions beyond those indicated under recommended operating conditions is not implied. Exposure to absolute-maximum-rated conditions for extended periods may affect device reliability.
- All voltage values, except differential I/O bus voltages, are with respect to network ground terminal.
- This tests survivability only and the output state of the receiver is not specified.
- The thermal shutdown typically occurs when the junction temperature reaches 165°C.

## RECOMMENDED OPERATING CONDITIONS

over operating free-air temperature range (unless otherwise noted)

		MIN	NOM	MAX	UNIT
$V_{CC}$	Supply voltage	4.5		5.5	V
$V_I$ or $V_{IC}$	Voltage at any bus terminal (separately or common mode)	-7 <sup>(1)</sup>		12	
$1/t_{UI}$	Signaling rate	SN65HVD50, SN65HVD53		25	Mbps
		SN65HVD51, SN65HVD54		5	
		SN65HVD52, SN65HVD55		1	
$R_L$	Differential load resistance	54	60		$\Omega$
$V_{IH}$	High-level input voltage	D, DE, $\overline{RE}$		$V_{CC}$	V
$V_{IL}$	Low-level input voltage	D, DE, $\overline{RE}$		0.8	
$V_{ID}$	Differential input voltage	-12		12	
$I_{OH}$	High-level output current	Driver		-60	
		Receiver		-8	
$I_{OL}$	Low-level output current	Driver		60	mA
		Receiver		8	
$T_J$ <sup>(2)</sup>	Junction temperature	-40		150	$^{\circ}\text{C}$

(1) The algebraic convention, in which the least positive (most negative) limit is designated as minimum is used in this data sheet.

(2) See thermal characteristics table for information regarding this specification.

## ELECTROSTATIC DISCHARGE PROTECTION

PARAMETER	TEST CONDITIONS	MIN	TYP <sup>(1)</sup>	MAX	UNIT
Human body model	Bus terminals and GND		$\pm 16$		kV
Human body model <sup>(2)</sup>	All pins		$\pm 4$		
Charged-device-model <sup>(3)</sup>	All pins		$\pm 1$		

(1) All typical values at 25°C and with a 5-V supply.

(2) Tested in accordance with JEDEC Standard 22, Test Method A114-A.

(3) Tested in accordance with JEDEC Standard 22, Test Method C101.

# SN65HVD50-SN65HVD55

SLLS666E – SEPTEMBER 2005 – REVISED OCTOBER 2009

[www.ti.com](http://www.ti.com)

## DRIVER ELECTRICAL CHARACTERISTICS

over recommended operating conditions unless otherwise noted

PARAMETER		TEST CONDITIONS	MIN	TYP (1)	MAX	UNIT	
$V_{I(K)}$	Input clamp voltage	$I_I = -18$ mA	-1.5			V	
$ V_{OD(SS)} $	Steady-state differential output voltage	$I_O = 0$	4		$V_{CC}$		
		$R_L = 54 \Omega$ , See <a href="#">Figure 1</a> (RS-485)	1.7	2.6			
		$R_L = 100 \Omega$ , See <a href="#">Figure 1</a> (RS-422)	2.4	3.2			
		$V_{test} = -7$ V to 12 V, See <a href="#">Figure 2</a>	1.6				
$\Delta V_{OD(SS)} $	Change in magnitude of steady-state differential output voltage between states	$R_L = 54 \Omega$ , See <a href="#">Figure 1</a> and <a href="#">Figure 2</a>	-0.2		0.2		
$V_{OD(RING)}$	Differential Output Voltage overshoot and undershoot	$R_L = 54 \Omega$ , $C_L = 50$ pF, See <a href="#">Figure 5</a> See <a href="#">Figure 3</a> for definition			10% <sup>(2)</sup>		
$V_{OC(PP)}$	Peak-to-peak common-mode output voltage	HVD50, HVD53		0.5			
		HVD51, HVD54	See <a href="#">Figure 4</a>	0.4			
		HVD52, HVD55		0.4			
$V_{OC(SS)}$	Steady-state common-mode output voltage	See <a href="#">Figure 4</a>	2.2		3.3		
$\Delta V_{OC(SS)}$	Change in steady-state common-mode output voltage		-0.1		0.1		
$I_{Z(Z)}$ or $I_{Y(Z)}$	High-impedance state output current	HVD50, HVD51, HVD52	$V_{CC} = 0$ V, $V_Z$ or $V_Y = 12$ V, Other input at 0 V		90	$\mu$ A	
			$V_{CC} = 0$ V, $V_Z$ or $V_Y = -7$ V, Other input at 0 V	-10			
		HVD53, HVD54, HVD55	$V_{CC} = 5$ V or 0 V, DE = 0 V $V_Z$ or $V_Y = 12$ V	Other input at 0 V			90
			$V_{CC} = 5$ V or 0 V, DE = 0 V $V_Z$ or $V_Y = -7$ V		-10		
$I_{Z(S)}$ or $I_{Y(S)}$	Short-circuit output current <sup>(3)</sup>	$V_Z$ or $V_Y = -7$ V	Other input at 0 V	-250	250	mA	
		$V_Z$ or $V_Y = 12$ V		-250	250		
$I_I$	Input current	D, DE	0		100	$\mu$ A	
$C_{(OD)}$	Differential output capacitance	$V_{OD} = 0.4 \sin(4E6\pi t) + 0.5$ V, DE at 0 V		16		pF	

(1) All typical values are at 25°C and with a 5-V supply.

(2) 10% of the peak-to-peak differential output voltage swing, per TIA/EIA-485

(3) Under some conditions of short-circuit to negative voltages, output currents exceeding the ANSI TIA/EIA-485-A maximum current of 250 mA may occur. Continuous exposure may affect device reliability.

## DRIVER SWITCHING CHARACTERISTICS

over recommended operating conditions unless otherwise noted

PARAMETER		TEST CONDITIONS	MIN	TYP <sup>(1)</sup>	MAX	UNIT
t <sub>PLH</sub>	Propagation delay time, low-to-high-level output	HVD50, HVD53	4	8	12	ns
		HVD51, HVD54	20	29	46	
		HVD52, HVD55	90	143	230	
t <sub>PHL</sub>	Propagation delay time, high-to-low-level output	HVD50, HVD53	4	8	12	ns
		HVD51, HVD54	20	30	46	
		HVD52, HVD55	90	143	230	
t <sub>r</sub>	Differential output signal rise time	HVD50, HVD53	3	6	12	ns
		HVD51, HVD54	20	34	60	
		HVD52, HVD55	120	197	300	
t <sub>f</sub>	Differential output signal fall time	HVD50, HVD53	3	6	11	ns
		HVD51, HVD54	20	33	60	
		HVD52, HVD55	120	192	300	
t <sub>sk(p)</sub>	Pulse skew ( t <sub>PHL</sub> – t <sub>PLH</sub>  )	HVD50, HVD53		1.4		ns
		HVD51, HVD54		1.6		
		HVD52, HVD55		7.4		
t <sub>sk(pp)</sub> <sup>(2)</sup>	Part-to-part skew	HVD50, HVD53		1		ns
		HVD51, HVD54		4		
		HVD52, HVD55		22		
t <sub>PZH1</sub>	Propagation delay time, high-impedance-to-high-level output	HVD53			30	ns
		HVD54			180	
		HVD55			380	
t <sub>PHZ</sub>	Propagation delay time, high-level-to-high-impedance output	HVD53			16	ns
		HVD54			40	
		HVD55			110	
t <sub>PZL1</sub>	Propagation delay time, high-impedance-to-low-level output	HVD53			23	ns
		HVD54			200	
		HVD55			420	
t <sub>PLZ</sub>	Propagation delay time, low-level-to-high-impedance output	HVD53			19	ns
		HVD54			70	
		HVD55			160	
t <sub>PZH2</sub>	Propagation delay time, standby-to-high-level output	R <sub>L</sub> = 110 Ω, $\overline{RE}$ at 3 V, See Figure 6 D = 3 V and S1 = Y, D = 0 V and S1 = Z			3300	ns
t <sub>PZL2</sub>	Propagation delay time, standby-to-low-level output	R <sub>L</sub> = 110 Ω, $\overline{RE}$ at 3 V, See Figure 7 D = 3 V and S1 = Z, D = 0 V and S1 = Y			3300	ns

(1) All typical values are at 25°C and with a 5-V supply.

 (2) t<sub>sk(pp)</sub> is the magnitude of the difference in propagation delay times between any specified terminals of two devices when both devices operate with the same supply voltages, at the same temperature, and have identical packages and test circuits.

# SN65HVD50-SN65HVD55

SLLS666E – SEPTEMBER 2005 – REVISED OCTOBER 2009

[www.ti.com](http://www.ti.com)

## RECEIVER ELECTRICAL CHARACTERISTICS

over recommended operating conditions unless otherwise noted

PARAMETER		TEST CONDITIONS		MIN	TYP <sup>(1)</sup>	MAX	UNIT	
$V_{IT+}$	Positive-going differential input threshold voltage	$I_O = -8$ mA				-0.02	V	
$V_{IT-}$	Negative-going differential input threshold voltage	$I_O = 8$ mA		-0.2				
$V_{hys}$	Hysteresis voltage ( $V_{IT+} - V_{IT-}$ )				50		mV	
$V_{IK}$	Enable-input clamp voltage	$I_I = -18$ mA		-1.5			V	
$V_O$	Output voltage	$V_{ID} = 200$ mV, $I_O = -8$ mA, See <a href="#">Figure 8</a>		4			V	
		$V_{ID} = -200$ mV, $I_O = 8$ mA, See <a href="#">Figure 8</a>				0.3		
$I_{O(Z)}$	High-impedance-state output current	$V_O = 0$ or $V_{CC}$ RE at $V_{CC}$		-1		1	$\mu$ A	
$I_A$ or $I_B$	Bus input current	HVD50, HVD53,	$V_A$ or $V_B = 12$ V	Other input at 0 V		0.19	0.3	mA
			$V_A$ or $V_B = 12$ V, $V_{CC} = 0$ V			0.24	0.4	
			$V_A$ or $V_B = -7$ V		-0.35	-0.19		
			$V_A$ or $V_B = -7$ V, $V_{CC} = 0$ V		-0.25	-0.14		
		HVD51, HVD52, HVD54, HVD55	$V_A$ or $V_B = 12$ V	Other input at 0 V		0.05	0.1	mA
			$V_A$ or $V_B = 12$ V, $V_{CC} = 0$ V			0.06	0.1	
			$V_A$ or $V_B = -7$ V		-0.1	-0.05		
			$V_A$ or $V_B = -7$ V, $V_{CC} = 0$ V		-0.1	-0.03		
$I_{IH}$	Input current, $\overline{RE}$	$V_{IH} = 2$ V		-60			$\mu$ A	
		$V_{IL} = 0.8$ V		-60			$\mu$ A	
$C_{ID}$	Differential input capacitance	$V_{ID} = 0.4 \sin(4E6\pi t) + 0.5$ V, DE at 0 V			16		pF	
<b>Supply Current</b>								
$I_{CC}$	Supply current	HVD50	D at 0 V or $V_{CC}$ and No Load			2.7	mA	
		HVD51, HVD52				8		
		HVD53		$\overline{RE}$ at 0 V, D at 0 V or $V_{CC}$ , DE at 0 V, No load (Receiver enabled and driver disabled)		2.3		
		HVD54, HVD55				2.9		
		HVD53, HVD54, HVD55	$\overline{RE}$ at $V_{CC}$ , D at $V_{CC}$ , DE at 0 V, No load (Receiver disabled and driver disabled)		0.08	1	$\mu$ A	
		HVD53	$\overline{RE}$ at 0 V, D at 0 V or $V_{CC}$ , DE at $V_{CC}$ , No load (Receiver enabled and driver enabled)			2.7	mA	
		HVD54, HVD55				8		
		HVD53		$\overline{RE}$ at $V_{CC}$ , D at 0 V or $V_{CC}$ , DE at $V_{CC}$		2.3		
HVD54, HVD55	No load (Receiver disabled and driver enabled)			7.7				

(1) All typical values are at 25°C and with a 5-V supply.

## RECEIVER SWITCHING CHARACTERISTICS

over recommended operating conditions unless otherwise noted

PARAMETER		TEST CONDITIONS	MIN	TYP <sup>(1)</sup>	MAX	UNIT	
t <sub>PLH</sub>	Propagation delay time, low-to-high-level output	HVD50, HVD53		24	40	ns	
		HVD51, HVD52, HVD54, HVD55		43	55		
t <sub>PHL</sub>	Propagation delay time, high-to-low-level output	HVD50, HVD53		26	35		
		HVD51, HVD52, HVD54, HVD55		47	60		
t <sub>sk(p)</sub>	Pulse skew ( t <sub>PHL</sub> - t <sub>PLH</sub>  )	HVD50, HVD53	V <sub>ID</sub> = -1.5 V to 1.5 V, C <sub>L</sub> = 15 pF, See <a href="#">Figure 9</a>				5
		HVD51, HVD54					7
t <sub>sk(pp)</sub> <sup>(2)</sup>	Part-to-part skew	HVD50, HVD53					5
		HVD51, HVD54					6
		HVD52, HVD55					6
t <sub>r</sub>	Output signal rise time				2.3		4
t <sub>f</sub>	Output signal fall time				2.4		4
t <sub>PHZ</sub>	Output disable time from high level	DE at 3 V, C <sub>L</sub> = 15 pF See <a href="#">Figure 10</a>					17
t <sub>PZH1</sub>	Output enable time to high level						10
t <sub>PZH2</sub>	Propagation delay time, standby-to-high-level output	DE at 0 V, C <sub>L</sub> = 15 pF See <a href="#">Figure 10</a>					3300
t <sub>PLZ</sub>	Output disable time from low level	DE at 3 V, C <sub>L</sub> = 15 pF See <a href="#">Figure 11</a>				13	
t <sub>PZL1</sub>	Output enable time to low level					10	
t <sub>PZL2</sub>	Propagation delay time, standby-to-low-level output	DE at 0 V, C <sub>L</sub> = 15 pF See <a href="#">Figure 11</a>				3300	

(1) All typical values are at 25°C and with a 5-V supply

 (2) t<sub>sk(pp)</sub> is the magnitude of the difference in propagation delay times between any specified terminals of two devices when both devices operate with the same supply voltages, at the same temperature, and have identical packages and test circuits.

## THERMAL CHARACTERISTICS

 over operating free-air temperature range unless otherwise noted<sup>(1)</sup>

PARAMETER		TEST CONDITIONS		MIN	TYP	MAX	UNIT
$\theta_{JA}$	Junction-to-ambient thermal resistance <sup>(2)</sup>	Low-K board <sup>(3)</sup> , No airflow	HVD50, HVD51, HVD52		230.8		°C/W
			HVD53, HVD54, HVD55		162.6		
	Junction-to-ambient thermal resistance <sup>(2)</sup>	High-K board <sup>(4)</sup> , No airflow	HVD50, HVD51, HVD52		135.1		
			HVD53, HVD54, HVD55		92.1		
$\theta_{JB}$	Junction-to-board thermal resistance	High-K board	HVD50, HVD51, HVD55		44.4		
			HVD53, HVD54, HVD55		61.1		
$\theta_{JC}$	Junction-to-case thermal resistance	No board	HVD50, HVD51, HVD52		43.5		
			HVD53, HVD54, HVD55		58.6		
$P_D$	Device power dissipation	$R_L = 60\Omega$ , $C_L = 50\text{ pF}$ , Input to D a 50% duty cycle square wave at indicated signaling rate	HVD50 (25Mbps)			420	mW
			HVD51 (10Mbps)			404	
			HVD52 (1Mbps)			383	
		$R_L = 60\Omega$ , $C_L = 50\text{ pF}$ , DE at $V_{CC}$ RE at 0 V, Input to D a 50% duty cycle square wave at indicated signaling rate	HVD53 (25Mbps)			420	
			HVD54 (10Mbps)			404	
			HVD55 (1Mbps)			383	
$T_A$	Ambient air temperature	Low-K board, No airflow	HVD50	-40		55	°C
			HVD51, HVD52	-40		84	
			HVD53, HVD54, HVD55	-40		85	
		High-K board, No airflow	HVD50, HVD51, HVD52	-40		85	
			HVD53, HVD54, HVD55	-40		85	
$T_{JSD}$	Thermal shutdown junction temperature				165		

- (1) See *Application Information* section for an explanation of these parameters.
- (2) The intent of  $\theta_{JA}$  specification is solely for a thermal performance comparison of one package to another in a standardized environment. This methodology is not meant to and will not predict the performance of a package in an application-specific environment.
- (3) In accordance with the Low-K thermal metric definitions of EIA/JESD51-3.
- (4) In accordance with the High-K thermal metric definitions of EIA/JESD51-7.

## PARAMETER MEASUREMENT INFORMATION

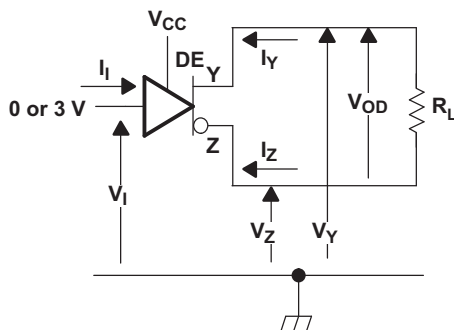

**Figure 1. Driver  $V_{OD}$  Test Circuit: Voltage and Current Definitions**

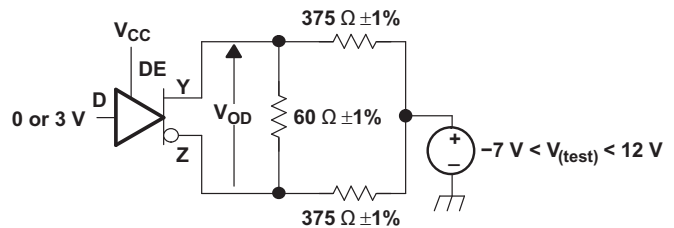

**Figure 2. Driver  $V_{OD}$  With Common-Mode Loading Test Circuit**

PARAMETER MEASUREMENT INFORMATION (continued)

VOD(RING) is measured at four points on the output waveform, corresponding to overshoot and undershoot from the VOD(H) and VOD(L) steady state values.

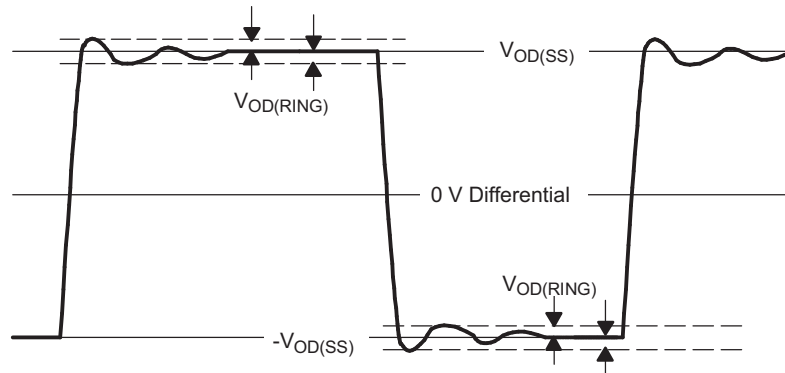
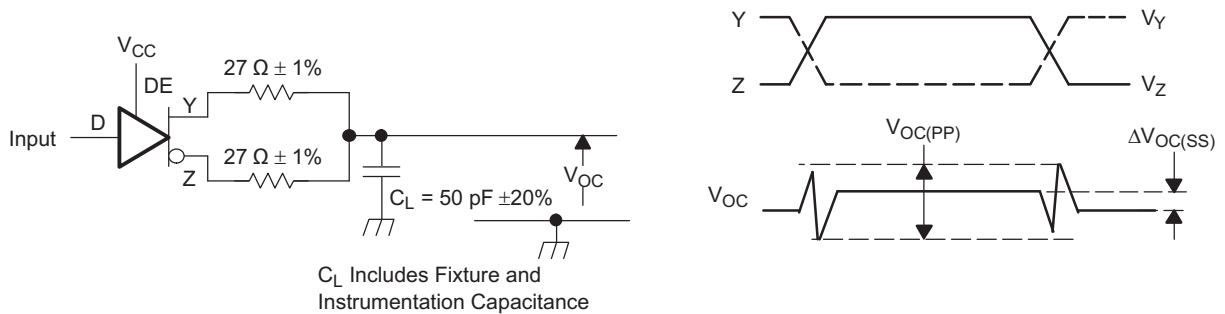
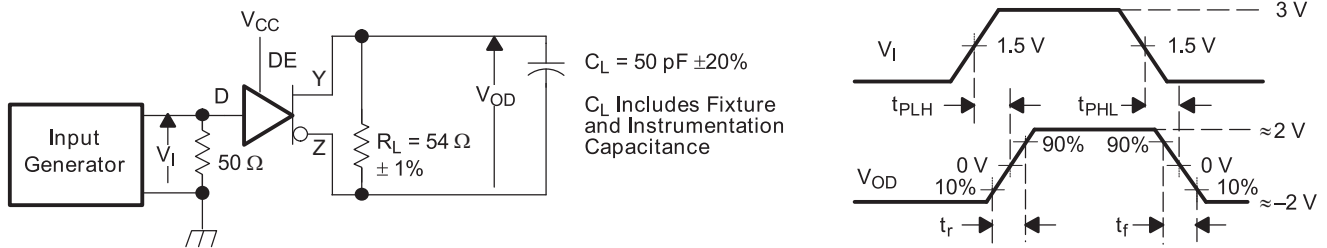

Figure 3. VOD(RING) Waveform and Definitions



Input: PRR = 500 kHz, 50% Duty Cycle,  $t_r < 6ns$ ,  $t_f < 6ns$ ,  $Z_O = 50 \Omega$

Figure 4. Test Circuit and Definitions for the Driver Common-Mode Output Voltage



Generator: PRR = 500 kHz, 50% Duty Cycle,  $t_r < 6 \text{ ns}$ ,  $t_f < 6 \text{ ns}$ ,  $Z_O = 50 \Omega$

Figure 5. Driver Switching Test Circuit and Voltage Waveforms

PARAMETER MEASUREMENT INFORMATION (continued)

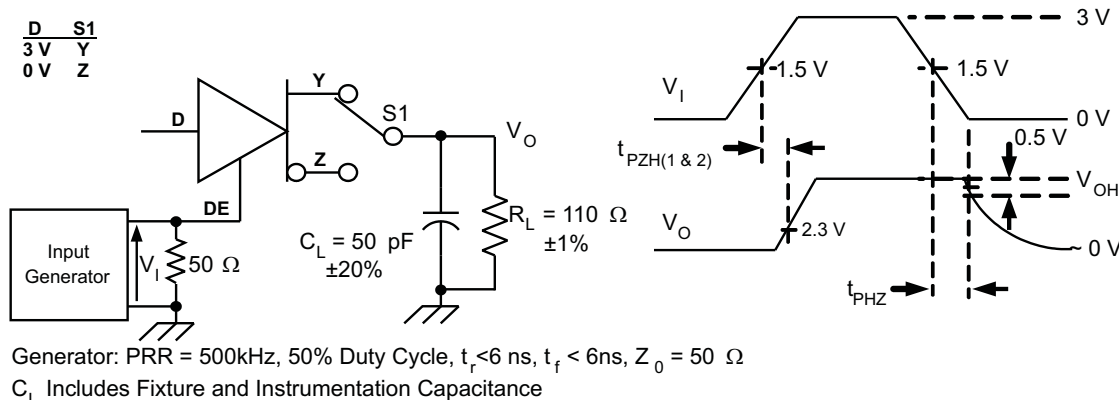

Figure 6. Driver High-Level Output Enable and Disable Time Test Circuit and Voltage Waveforms

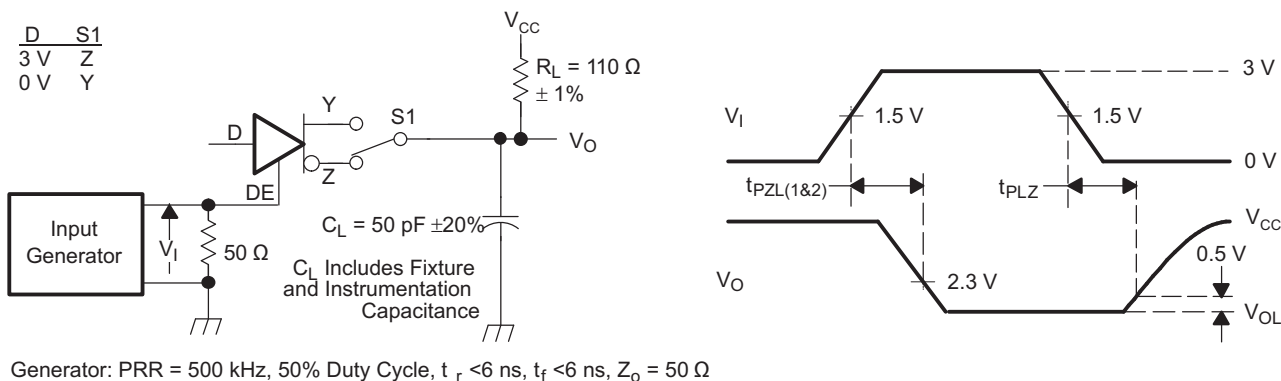

Figure 7. Driver Low-Level Output Enable and Disable Time Test Circuit and Voltage Waveforms

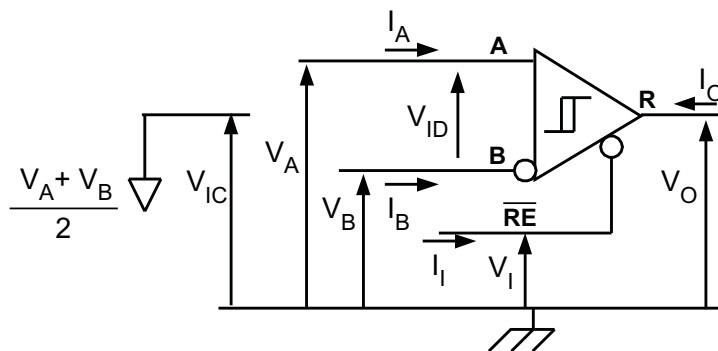

Figure 8. Receiver Voltage and Current Definitions

PARAMETER MEASUREMENT INFORMATION (continued)

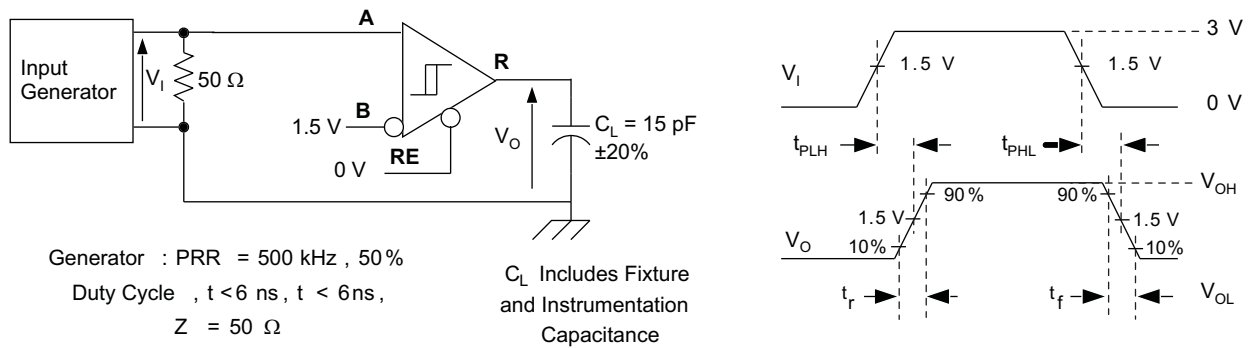

Figure 9. Receiver Switching Test Circuit and Voltage Waveforms

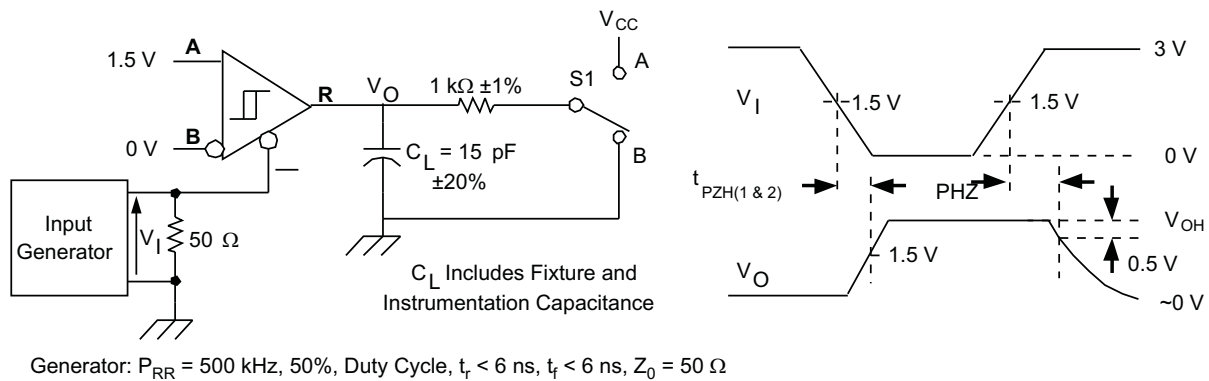

Figure 10. Receiver High-Level Enable and Disable Time Test Circuit and Voltage Waveforms

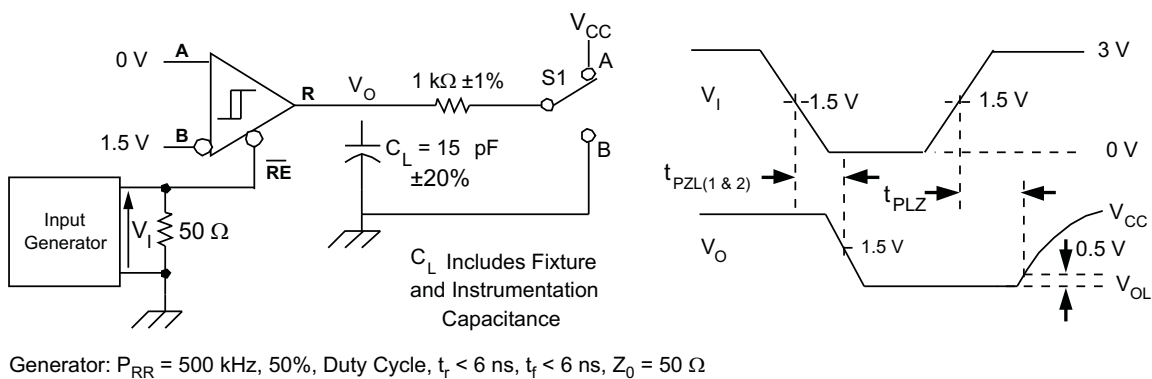

Figure 11. Receiver Low-Level Enable and Disable Time Test Circuit and Voltage Waveforms

PARAMETER MEASUREMENT INFORMATION (continued)

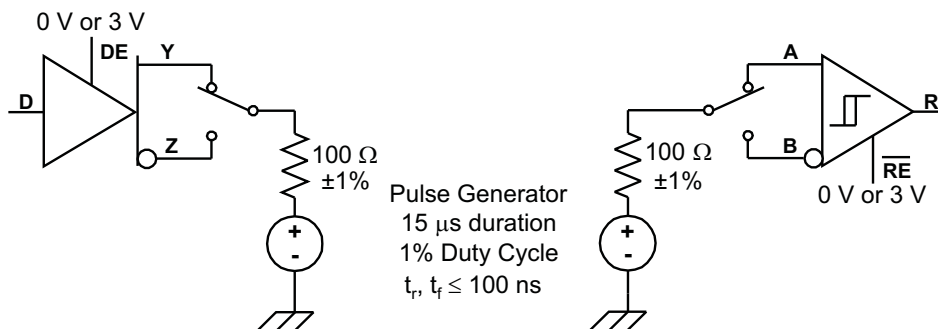

Figure 12. Test Circuit, Transient Overvoltage Test

DEVICE INFORMATION

LOW-POWER STANDBY MODE

When both the driver and receiver are disabled (DE low and  $\overline{RE}$  high) the device is in standby mode. If the enable inputs are in this state for less than 60 ns, the device does not enter standby mode. This guards against inadvertently entering standby mode during driver/receiver enabling. Only when the enable inputs are held in this state for 300 ns or more, the device is assured to be in standby mode. In this low-power standby mode, most internal circuitry is powered down, and the supply current is typically less than 1 nA. When either the driver or the receiver is re-enabled, the internal circuitry becomes active.

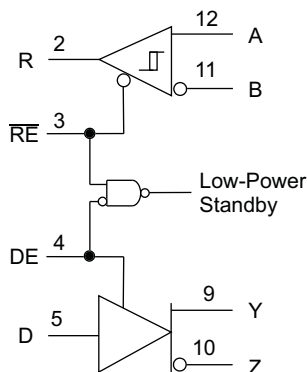

Figure 13. Low-Power Standby Logic Diagram

If only the driver is re-enabled (DE transitions to high) the driver outputs are driven according to the D input after the enable times given by  $t_{PZH2}$  and  $t_{PZL2}$  in the driver switching characteristics. If the D input is open when the driver is enabled, the driver outputs default to A high and B low, in accordance with the driver failsafe feature.

If only the receiver is re-enabled ( $\overline{RE}$  transitions to low) the receiver output is driven according to the state of the bus inputs (A and B) after the enable times given by  $t_{PZH2}$  and  $t_{PZL2}$  in the receiver switching characteristics. If there is no valid state on the bus the receiver responds as described in the failsafe operation section.

If both the receiver and driver are re-enabled simultaneously, the receiver output is driven according to the state of the bus inputs (A and B) and the driver output is driven according to the D input. Note that the state of the active driver affects the inputs to the receiver. Therefore, the receiver outputs are valid as soon as the driver outputs are valid.

**FUNCTION TABLES**
**Table 1. SN65HVD53, SN65HVD54, SN65HVD55  
DRIVER**

INPUTS		OUTPUTS	
D	DE	Y	Z
H	H	H	L
L	H	L	H
X	L or open	Z	Z
Open	H	L	H

**Table 2. SN65HVD53, SN65HVD54, SN65HVD55  
RECEIVER**

DIFFERENTIAL INPUTS $V_{ID} = V_{(A)} - V_{(B)}$	ENABLE $\overline{RE}$	OUTPUT R
$V_{ID} \leq -0.2 \text{ V}$	L	L
$-0.2 \text{ V} < V_{ID} < -0.02 \text{ V}$	L	?
$-0.02 \text{ V} \leq V_{ID}$	L	H
X	H or open	Z
Open Circuit	L	H
Idle circuit	L	H
Short Circuit, $V_{(A)} = V_{(B)}$	L	H

**Table 3. SN65HVD50, SN65HVD51, SN65HVD52  
DRIVER**

INPUT D	OUTPUTS	
	Y	Z
H	H	L
L	L	H
Open	L	H

**Table 4. SN65HVD50, SN65HVD51, SN65HVD52  
RECEIVER**

DIFFERENTIAL INPUTS $V_{ID} = V_{(A)} - V_{(B)}$	OUTPUT R
$V_{ID} \leq -0.2 \text{ V}$	L
$-0.2 \text{ V} < V_{ID} < -0.02 \text{ V}$	?
$-0.02 \text{ V} \leq V_{ID}$	H
Open Circuit	H
Idle circuit	H
Short Circuit, $V_{(A)} = V_{(B)}$	H

# SN65HVD50-SN65HVD55

SLLS666E – SEPTEMBER 2005 – REVISED OCTOBER 2009

www.ti.com

## EQUIVALENT INPUT AND OUTPUT SCHEMATIC DIAGRAMS

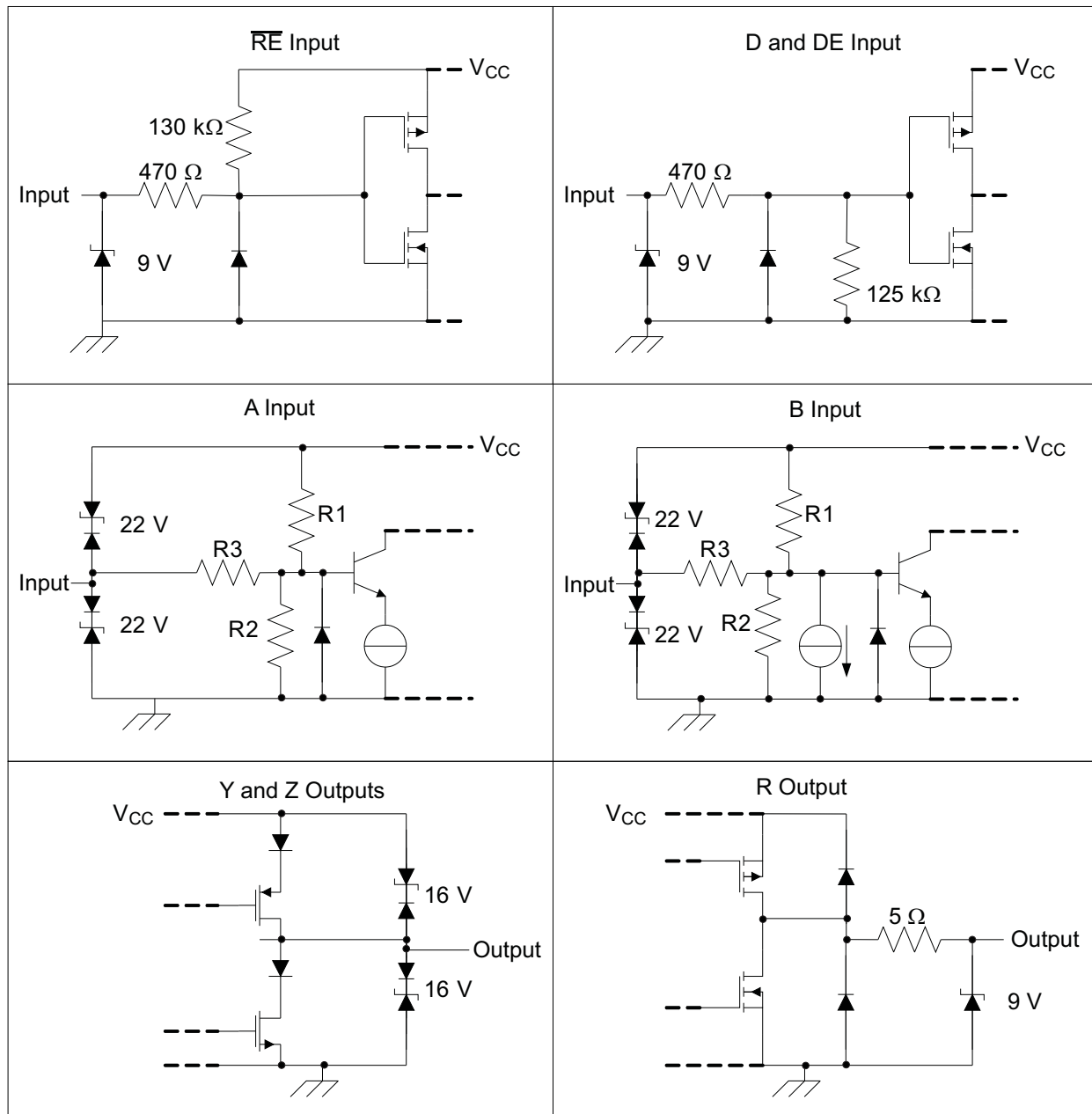

	R1/R2	R3
SN65HVD50, SN65HVD53	9 kΩ	45 kΩ
SN65HVD51, SN65HVD52, SN65HVD54, SN65HVD55	36 kΩ	180 kΩ

TYPICAL CHARACTERISTICS

HVD50, HVD53  
RMS SUPPLY CURRENT  
vs  
SIGNALING RATE

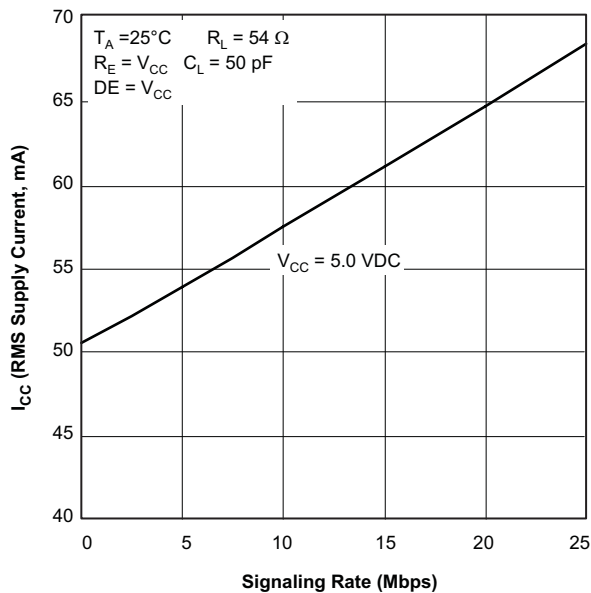

Figure 14.

HVD51, HVD54  
RMS SUPPLY CURRENT  
vs  
SIGNALING RATE

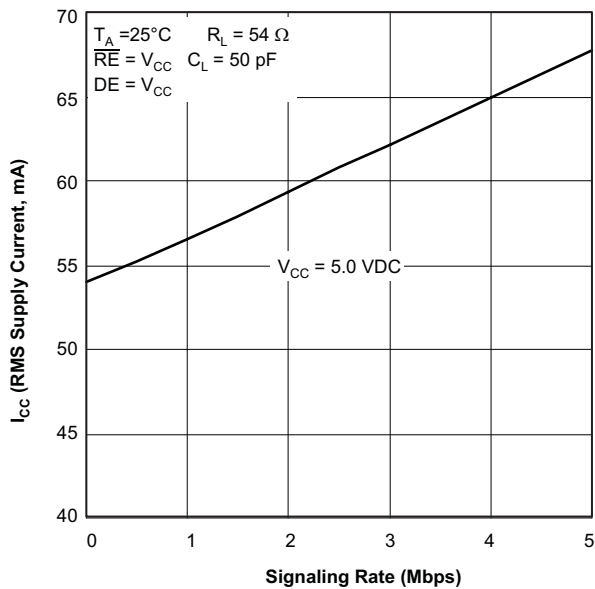

Figure 15.

HVD52, HVD55  
RMS SUPPLY CURRENT  
vs  
SIGNALING RATE

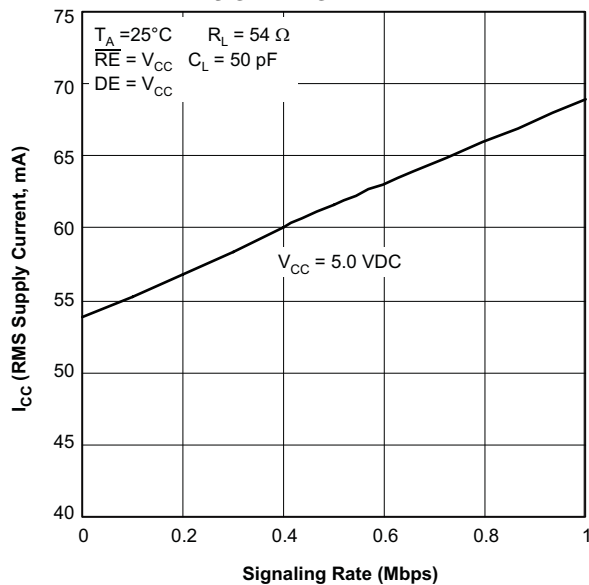

Figure 16.

TYPICAL CHARACTERISTICS (continued)

HVD50, HVD53  
BUS INPUT CURRENT  
vs  
INPUT VOLTAGE

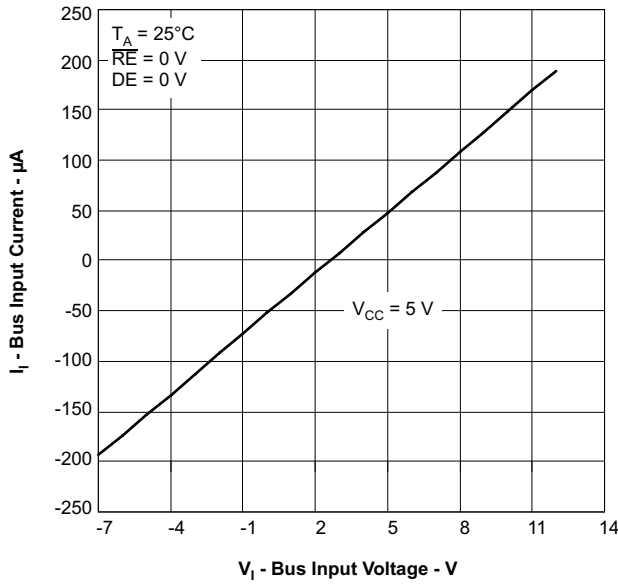

Figure 17.

HVD51, HVD52, HVD54, HVD55  
BUS INPUT CURRENT  
vs  
INPUT VOLTAGE

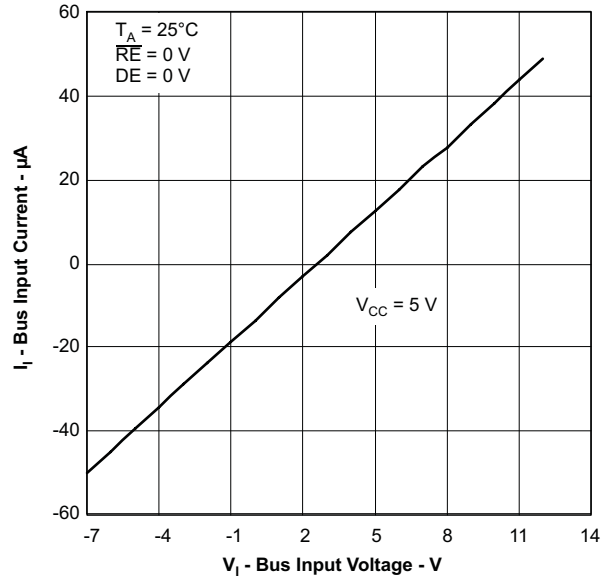

Figure 18.

DRIVER LOW-LEVEL OUTPUT CURRENT  
vs  
LOW-LEVEL OUTPUT VOLTAGE

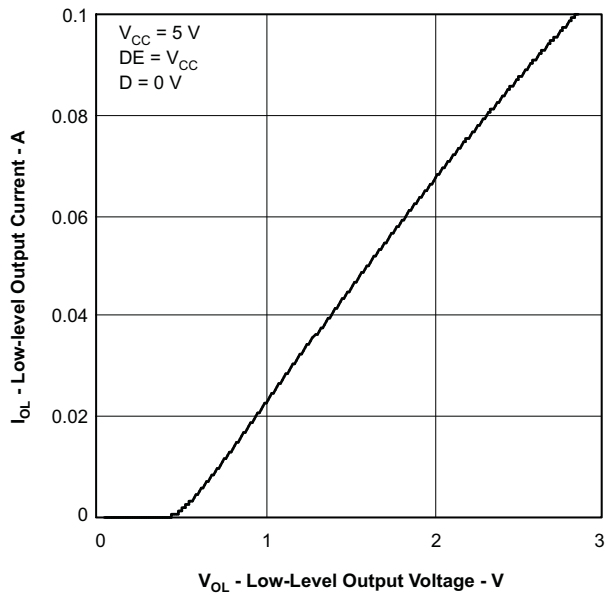

Figure 19.

DRIVER HIGH-LEVEL OUTPUT CURRENT  
vs  
HIGH-LEVEL OUTPUT VOLTAGE

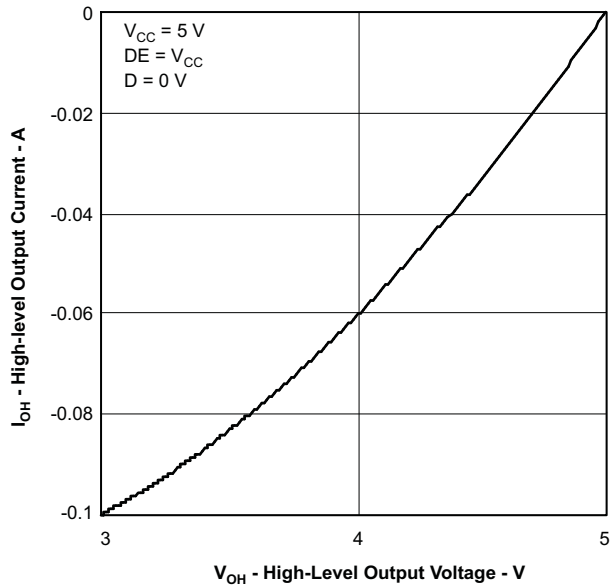

Figure 20.

TYPICAL CHARACTERISTICS (continued)

DRIVER DIFFERENTIAL OUTPUT VOLTAGE  
VS  
FREE-AIR TEMPERATURE

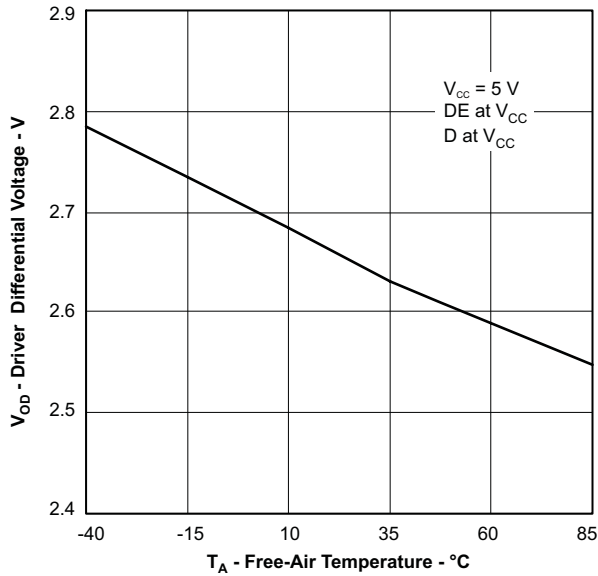

Figure 21.

DRIVER OUTPUT CURRENT  
VS  
SUPPLY VOLTAGE

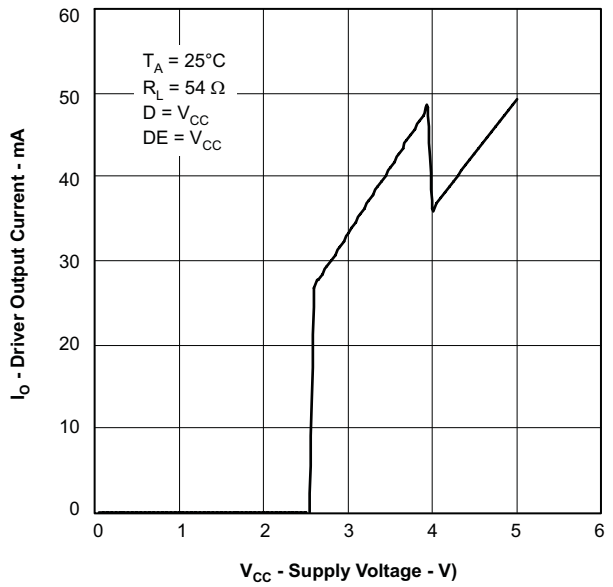

Figure 22.

ENABLE TIME  
VS  
COMMON-MODE VOLTAGE (SEE Figure 25)

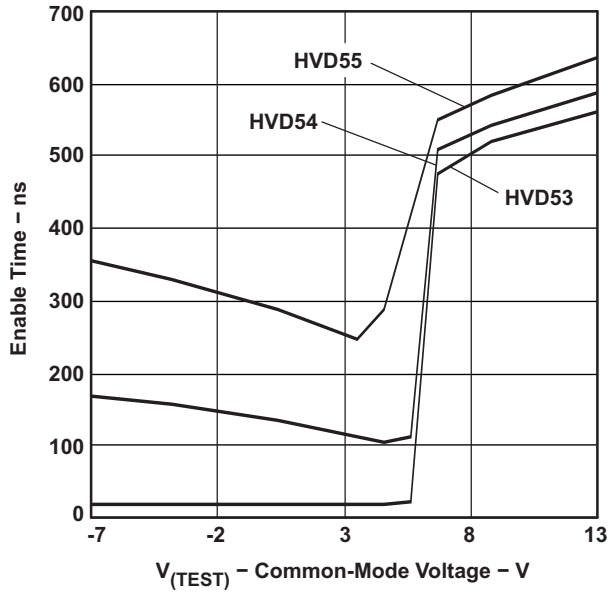

Figure 23.

DIFERENTIAL OUTPUT VOLTAGE  
VS  
OUTPUT CURRENT

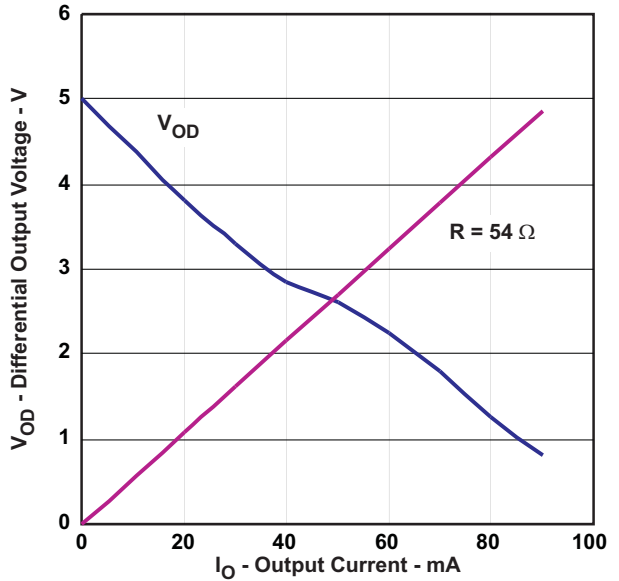

Figure 24.

TYPICAL CHARACTERISTICS (continued)

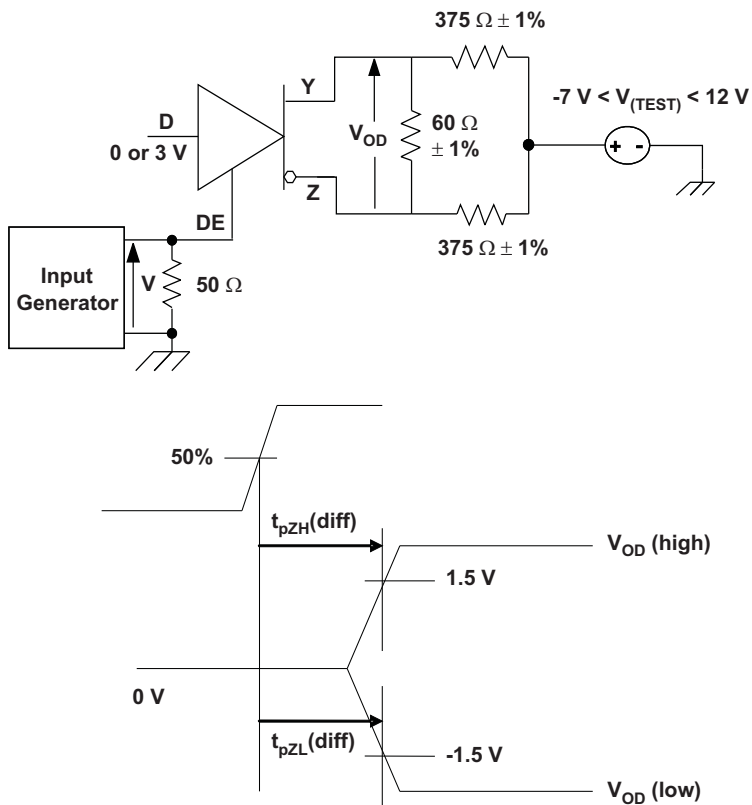

Figure 25. Driver Enable Time From DE to V<sub>OD</sub>

The time  $t_{pZL}(x)$  is the measure from DE to  $V_{OD}(x)$ .  $V_{OD}$  is valid when it is greater than 1.5 V.

## APPLICATION INFORMATION

### THERMAL CHARACTERISTICS OF IC PACKAGES

$\theta_{JA}$  (**Junction-to-Ambient Thermal Resistance**) is defined as the difference in junction temperature to ambient temperature divided by the operating power.

$\theta_{JA}$  is not a constant and is a strong function of:

- the PCB design (50% variation)
- altitude (20% variation)
- device power (5% variation)

$\theta_{JA}$  can be used to compare the thermal performance of packages if the specific test conditions are defined and used. Standardized testing includes specification of PCB construction, test chamber volume, sensor locations, and the thermal characteristics of holding fixtures.  $\theta_{JA}$  is often misused when it is used to calculate junction temperatures for other installations.

TI uses two test PCBs as defined by JEDEC specifications. The low-k board gives *average* in-use condition thermal performance, and it consists of a single copper trace layer 25 mm long and 2-oz thick. The high-k board gives *best case* in-use condition, and it consists of two 1-oz buried power planes with a single copper trace layer 25 mm long and 2-oz thick. A 4% to 50% difference in  $\theta_{JA}$  can be measured between these two test cards

$\theta_{JC}$  (**Junction-to-Case Thermal Resistance**) is defined as difference in junction temperature to case divided by the operating power. It is measured by putting the mounted package up against a copper block cold plate to force heat to flow from die, through the mold compound into the copper block.

$\theta_{JC}$  is a useful thermal characteristic when a heatsink applied to package. It is *not* a useful characteristic to predict junction temperature because it provides pessimistic numbers if the case temperature is measured in a nonstandard system and junction temperatures are backed out. It can be used with  $\theta_{JB}$  in 1-dimensional thermal simulation of a package system.

$\theta_{JB}$  (**Junction-to-Board Thermal Resistance**) is defined as the difference in the junction temperature and the PCB temperature at the center of the package (closest to the die) when the PCB is clamped in a cold-plate structure.  $\theta_{JB}$  is only defined for the high-k test card.

$\theta_{JB}$  provides an overall thermal resistance between the die and the PCB. It includes a bit of the PCB thermal resistance (especially for BGA's with thermal balls) and can be used for simple 1-dimensional network analysis of package system, see [Figure 26](#).

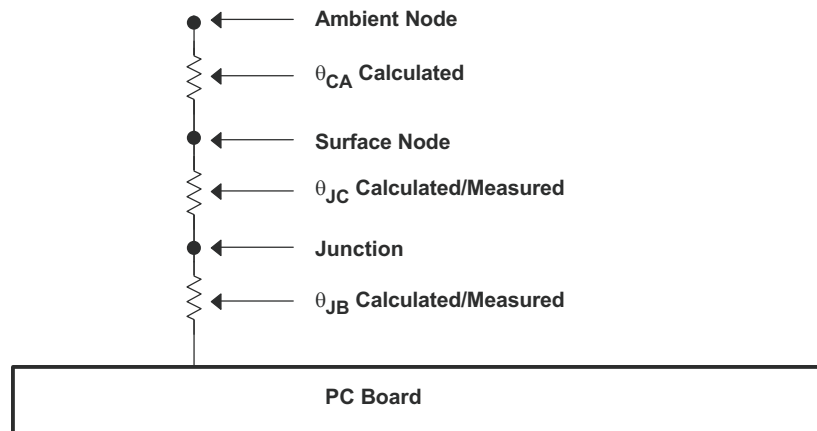



Figure 26. Thermal Resistance

## REVISION HISTORY

<b>Changes from Original (September 2005) to Revision A</b>	<b>Page</b>
• Changed the Description and illustration .....	1
• Changed device SN65HVD50, 51, and 52 SOIC Markings From Preview To 65HVD50, 65HVD51, and 65HVD52 .....	2
• Changed the Abs Max Table to include $V_{(A)}$ , $V_{(B)}$ , $V_{(Y)}$ , $V_{(Z)}$ and $P_{D(cont)}$ .....	2
• Changed $V_{OD(RING)}$ Max value From $0.05 V_{OD(SS)} $ To: 10% with the associated note. ....	4
• Changed $t_r$ MIN value From: 25 ns To: 20 ns .....	5
• Changed $t_f$ MIN value From: 25 ns To: 20 ns .....	5
• Changed Supply Current - HVD50 MAX value From 8 mA To: 2.7 mA .....	6
• Changed section LOW-POWER SHUTDOWN MODE To: LOW-POWER STANDBY MODE .....	12
<hr/>	
<b>Changes from Revision A (February 2006) to Revision B</b>	<b>Page</b>
• Added $t_{sk(p)}$ TYP Values .....	5
• Deleted $t_{sk(p)}$ MAX Values .....	5
<hr/>	
<b>Changes from Revision B (May 2006) to Revision C</b>	<b>Page</b>
• Added <a href="#">Figure 23</a> .....	17
• Added <a href="#">Figure 25</a> .....	17
<hr/>	
<b>Changes from Revision C (July 2006) to Revision D</b>	<b>Page</b>
• Changed text of feature bullet From: Meets or Exceeds the Requirements of ANSI TIA/EIA-485-A and RS-422 Compatible To: Designed for RS-422 and RS485 Networks .....	1
<hr/>	
<b>Changes from Revision D (June 2008) to Revision E</b>	<b>Page</b>
• Changed text of feature bullet From: 3.3-V Devices Available, SN65HVD30-39 To: 3.3-V Devices Available, SN65HVD30-35 .....	1
• Deleted all references to SN65HVD56, SN65HVD57, SN65HVD58, SN65HVD59 throughout the data sheet .....	1
• Deleted RECEIVER EQUALIZATION CHARACTERISTICS from the data sheet. ....	2
• Changed scale of <a href="#">Figure 19</a> .....	16
• Changed scale of <a href="#">Figure 20</a> .....	16
• Added <a href="#">Figure 24</a> .....	17
• Changed <a href="#">Figure 26</a> .....	19

**PACKAGING INFORMATION**

Orderable Device	Status (1)	Package Type	Package Drawing	Pins	Package Qty	Eco Plan (2)	Lead/Ball Finish (6)	MSL Peak Temp (3)	Op Temp (°C)	Device Marking (4/5)	Samples
SN65HVD50D	ACTIVE	SOIC	D	8	75	Green (RoHS & no Sb/Br)	CU NIPDAU	Level-1-260C-UNLIM	-40 to 85	VP50	<a href="#">Samples</a>
SN65HVD50DG4	ACTIVE	SOIC	D	8	75	Green (RoHS & no Sb/Br)	CU NIPDAU	Level-1-260C-UNLIM	-40 to 85	VP50	<a href="#">Samples</a>
SN65HVD50DR	ACTIVE	SOIC	D	8	2500	Green (RoHS & no Sb/Br)	CU NIPDAU	Level-1-260C-UNLIM	-40 to 85	VP50	<a href="#">Samples</a>
SN65HVD51D	ACTIVE	SOIC	D	8	75	Green (RoHS & no Sb/Br)	CU NIPDAU	Level-1-260C-UNLIM	-40 to 85	VP51	<a href="#">Samples</a>
SN65HVD51DR	ACTIVE	SOIC	D	8	2500	Green (RoHS & no Sb/Br)	CU NIPDAU	Level-1-260C-UNLIM	-40 to 85	VP51	<a href="#">Samples</a>
SN65HVD52D	ACTIVE	SOIC	D	8	75	Green (RoHS & no Sb/Br)	CU NIPDAU	Level-1-260C-UNLIM	-40 to 85	VP52	<a href="#">Samples</a>
SN65HVD52DR	ACTIVE	SOIC	D	8	2500	Green (RoHS & no Sb/Br)	CU NIPDAU	Level-1-260C-UNLIM	-40 to 85	VP52	<a href="#">Samples</a>
SN65HVD53D	ACTIVE	SOIC	D	14	50	Green (RoHS & no Sb/Br)	CU NIPDAU	Level-1-260C-UNLIM	-40 to 85	65HVD53	<a href="#">Samples</a>
SN65HVD53DG4	ACTIVE	SOIC	D	14	50	Green (RoHS & no Sb/Br)	CU NIPDAU	Level-1-260C-UNLIM	-40 to 85	65HVD53	<a href="#">Samples</a>
SN65HVD53DR	ACTIVE	SOIC	D	14	2500	Green (RoHS & no Sb/Br)	CU NIPDAU	Level-1-260C-UNLIM	-40 to 85	65HVD53	<a href="#">Samples</a>
SN65HVD53DRG4	ACTIVE	SOIC	D	14	2500	Green (RoHS & no Sb/Br)	CU NIPDAU	Level-1-260C-UNLIM	-40 to 85	65HVD53	<a href="#">Samples</a>
SN65HVD54D	ACTIVE	SOIC	D	14	50	Green (RoHS & no Sb/Br)	CU NIPDAU	Level-1-260C-UNLIM	-40 to 85	65HVD54	<a href="#">Samples</a>
SN65HVD54DG4	ACTIVE	SOIC	D	14	50	Green (RoHS & no Sb/Br)	CU NIPDAU	Level-1-260C-UNLIM	-40 to 85	65HVD54	<a href="#">Samples</a>
SN65HVD54DR	ACTIVE	SOIC	D	14	2500	Green (RoHS & no Sb/Br)	CU NIPDAU	Level-1-260C-UNLIM	-40 to 85	65HVD54	<a href="#">Samples</a>
SN65HVD54DRG4	ACTIVE	SOIC	D	14	2500	Green (RoHS & no Sb/Br)	CU NIPDAU	Level-1-260C-UNLIM	-40 to 85	65HVD54	<a href="#">Samples</a>
SN65HVD55D	ACTIVE	SOIC	D	14	50	Green (RoHS & no Sb/Br)	CU NIPDAU	Level-1-260C-UNLIM	-40 to 85	65HVD55	<a href="#">Samples</a>
SN65HVD55DG4	ACTIVE	SOIC	D	14	50	Green (RoHS & no Sb/Br)	CU NIPDAU	Level-1-260C-UNLIM	-40 to 85	65HVD55	<a href="#">Samples</a>

Orderable Device	Status (1)	Package Type	Package Drawing	Pins	Package Qty	Eco Plan (2)	Lead/Ball Finish (6)	MSL Peak Temp (3)	Op Temp (°C)	Device Marking (4/5)	Samples
SN65HVD55DR	ACTIVE	SOIC	D	14	2500	Green (RoHS & no Sb/Br)	CU NIPDAU	Level-1-260C-UNLIM	-40 to 85	65HVD55	
SN65HVD55DRG4	ACTIVE	SOIC	D	14	2500	Green (RoHS & no Sb/Br)	CU NIPDAU	Level-1-260C-UNLIM	-40 to 85	65HVD55	

(1) The marketing status values are defined as follows:

**ACTIVE:** Product device recommended for new designs.

**LIFEBUY:** TI has announced that the device will be discontinued, and a lifetime-buy period is in effect.

**NRND:** Not recommended for new designs. Device is in production to support existing customers, but TI does not recommend using this part in a new design.

**PREVIEW:** Device has been announced but is not in production. Samples may or may not be available.

**OBSELETE:** TI has discontinued the production of the device.

(2) Eco Plan - The planned eco-friendly classification: Pb-Free (RoHS), Pb-Free (RoHS Exempt), or Green (RoHS & no Sb/Br) - please check <http://www.ti.com/productcontent> for the latest availability information and additional product content details.

**TBD:** The Pb-Free/Green conversion plan has not been defined.

**Pb-Free (RoHS):** TI's terms "Lead-Free" or "Pb-Free" mean semiconductor products that are compatible with the current RoHS requirements for all 6 substances, including the requirement that lead not exceed 0.1% by weight in homogeneous materials. Where designed to be soldered at high temperatures, TI Pb-Free products are suitable for use in specified lead-free processes.

**Pb-Free (RoHS Exempt):** This component has a RoHS exemption for either 1) lead-based flip-chip solder bumps used between the die and package, or 2) lead-based die adhesive used between the die and leadframe. The component is otherwise considered Pb-Free (RoHS compatible) as defined above.

**Green (RoHS & no Sb/Br):** TI defines "Green" to mean Pb-Free (RoHS compatible), and free of Bromine (Br) and Antimony (Sb) based flame retardants (Br or Sb do not exceed 0.1% by weight in homogeneous material)

(3) MSL, Peak Temp. - The Moisture Sensitivity Level rating according to the JEDEC industry standard classifications, and peak solder temperature.

(4) There may be additional marking, which relates to the logo, the lot trace code information, or the environmental category on the device.

(5) Multiple Device Markings will be inside parentheses. Only one Device Marking contained in parentheses and separated by a "~" will appear on a device. If a line is indented then it is a continuation of the previous line and the two combined represent the entire Device Marking for that device.

(6) Lead/Ball Finish - Orderable Devices may have multiple material finish options. Finish options are separated by a vertical ruled line. Lead/Ball Finish values may wrap to two lines if the finish value exceeds the maximum column width.

**Important Information and Disclaimer:** The information provided on this page represents TI's knowledge and belief as of the date that it is provided. TI bases its knowledge and belief on information provided by third parties, and makes no representation or warranty as to the accuracy of such information. Efforts are underway to better integrate information from third parties. TI has taken and continues to take reasonable steps to provide representative and accurate information but may not have conducted destructive testing or chemical analysis on incoming materials and chemicals. TI and TI suppliers consider certain information to be proprietary, and thus CAS numbers and other limited information may not be available for release.

In no event shall TI's liability arising out of such information exceed the total purchase price of the TI part(s) at issue in this document sold by TI to Customer on an annual basis.

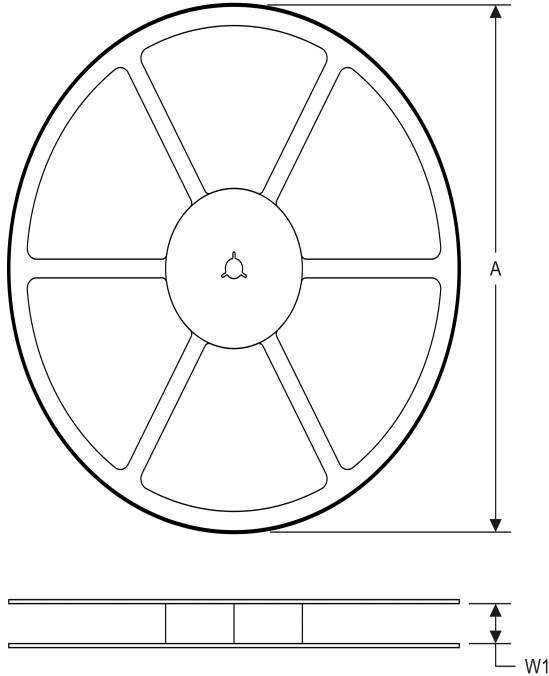
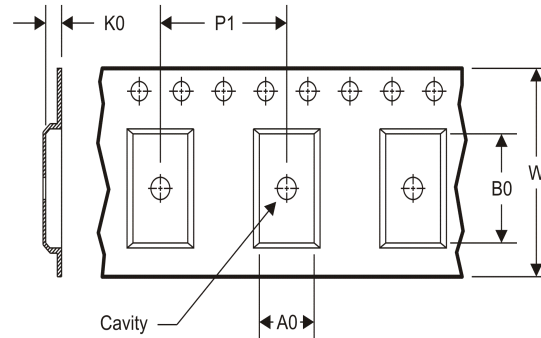

**TAPE AND REEL INFORMATION**
**REEL DIMENSIONS**

**TAPE DIMENSIONS**

A0	Dimension designed to accommodate the component width
B0	Dimension designed to accommodate the component length
K0	Dimension designed to accommodate the component thickness
W	Overall width of the carrier tape
P1	Pitch between successive cavity centers

**TAPE AND REEL INFORMATION**

\*All dimensions are nominal

Device	Package Type	Package Drawing	Pins	SPQ	Reel Diameter (mm)	Reel Width W1 (mm)	A0 (mm)	B0 (mm)	K0 (mm)	P1 (mm)	W (mm)	Pin1 Quadrant
SN65HVD50DR	SOIC	D	8	2500	330.0	12.4	6.4	5.2	2.1	8.0	12.0	Q1
SN65HVD51DR	SOIC	D	8	2500	330.0	12.4	6.4	5.2	2.1	8.0	12.0	Q1
SN65HVD52DR	SOIC	D	8	2500	330.0	12.4	6.4	5.2	2.1	8.0	12.0	Q1
SN65HVD53DR	SOIC	D	14	2500	330.0	16.4	6.5	9.0	2.1	8.0	16.0	Q1
SN65HVD54DR	SOIC	D	14	2500	330.0	16.4	6.5	9.0	2.1	8.0	16.0	Q1
SN65HVD55DR	SOIC	D	14	2500	330.0	16.4	6.5	9.0	2.1	8.0	16.0	Q1

**TAPE AND REEL BOX DIMENSIONS**

\*All dimensions are nominal

Device	Package Type	Package Drawing	Pins	SPQ	Length (mm)	Width (mm)	Height (mm)
SN65HVD50DR	SOIC	D	8	2500	367.0	367.0	35.0
SN65HVD51DR	SOIC	D	8	2500	367.0	367.0	35.0
SN65HVD52DR	SOIC	D	8	2500	367.0	367.0	35.0
SN65HVD53DR	SOIC	D	14	2500	367.0	367.0	38.0
SN65HVD54DR	SOIC	D	14	2500	367.0	367.0	38.0
SN65HVD55DR	SOIC	D	14	2500	367.0	367.0	38.0



D (R-PDSO-G14)

PLASTIC SMALL OUTLINE



4211283-3/E 08/12

- NOTES:
- All linear dimensions are in millimeters.
  - This drawing is subject to change without notice.
  - Publication IPC-7351 is recommended for alternate designs.
  - Laser cutting apertures with trapezoidal walls and also rounding corners will offer better paste release. Customers should contact their board assembly site for stencil design recommendations. Refer to IPC-7525 for other stencil recommendations.
  - Customers should contact their board fabrication site for solder mask tolerances between and around signal pads.

D (R-PDSO-G8)

PLASTIC SMALL OUTLINE

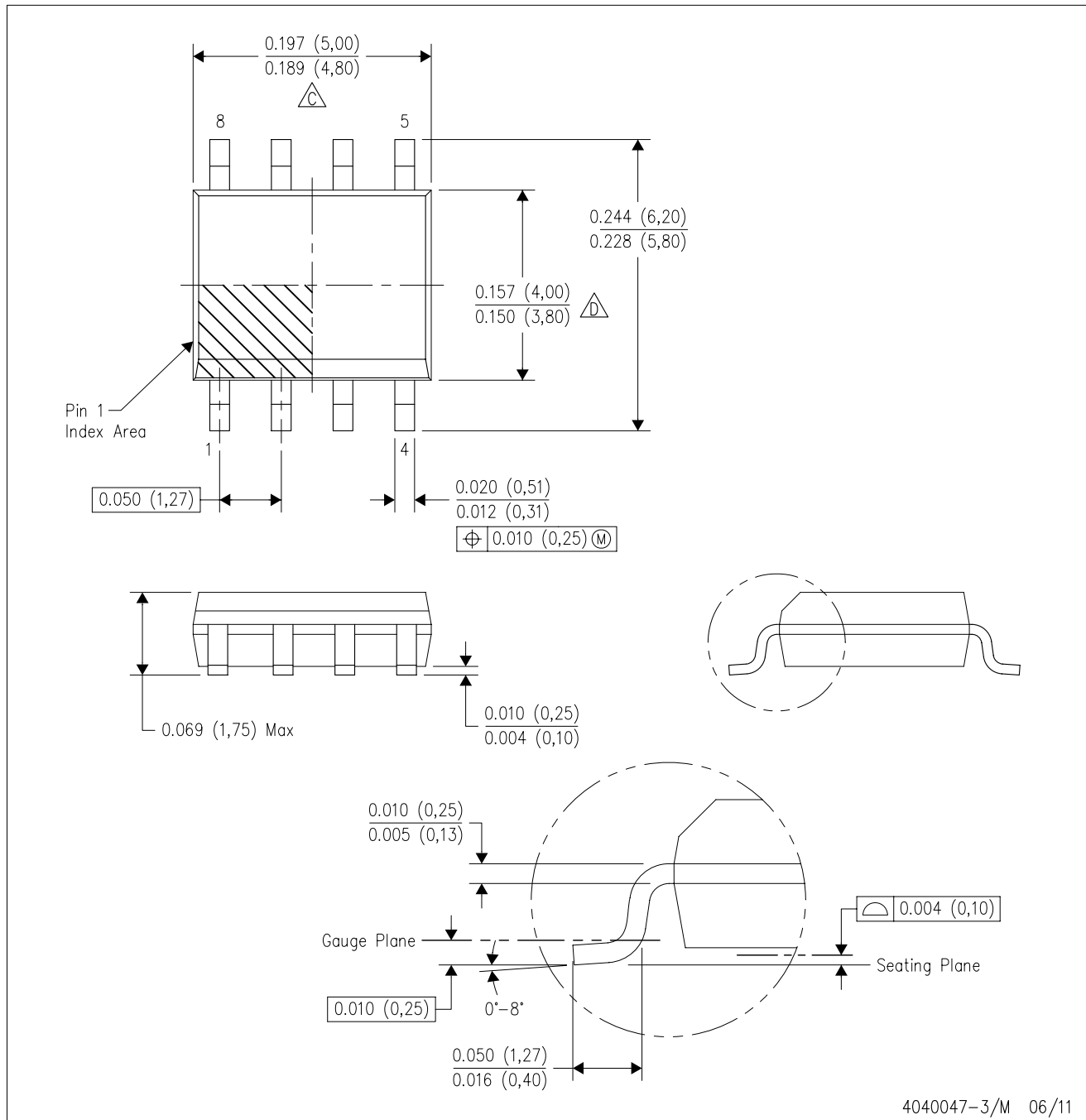

- NOTES:
- A. All linear dimensions are in inches (millimeters).
  - B. This drawing is subject to change without notice.
  - $\triangle C$  Body length does not include mold flash, protrusions, or gate burrs. Mold flash, protrusions, or gate burrs shall not exceed 0.006 (0,15) each side.
  - $\triangle D$  Body width does not include interlead flash. Interlead flash shall not exceed 0.017 (0,43) each side.
  - E. Reference JEDEC MS-012 variation AA.

D (R-PDSO-G8)

PLASTIC SMALL OUTLINE



- NOTES:
- All linear dimensions are in millimeters.
  - This drawing is subject to change without notice.
  - Publication IPC-7351 is recommended for alternate designs.
  - Laser cutting apertures with trapezoidal walls and also rounding corners will offer better paste release. Customers should contact their board assembly site for stencil design recommendations. Refer to IPC-7525 for other stencil recommendations.
  - Customers should contact their board fabrication site for solder mask tolerances between and around signal pads.

## IMPORTANT NOTICE

Texas Instruments Incorporated and its subsidiaries (TI) reserve the right to make corrections, enhancements, improvements and other changes to its semiconductor products and services per JESD46, latest issue, and to discontinue any product or service per JESD48, latest issue. Buyers should obtain the latest relevant information before placing orders and should verify that such information is current and complete. All semiconductor products (also referred to herein as "components") are sold subject to TI's terms and conditions of sale supplied at the time of order acknowledgment.

TI warrants performance of its components to the specifications applicable at the time of sale, in accordance with the warranty in TI's terms and conditions of sale of semiconductor products. Testing and other quality control techniques are used to the extent TI deems necessary to support this warranty. Except where mandated by applicable law, testing of all parameters of each component is not necessarily performed.

TI assumes no liability for applications assistance or the design of Buyers' products. Buyers are responsible for their products and applications using TI components. To minimize the risks associated with Buyers' products and applications, Buyers should provide adequate design and operating safeguards.

TI does not warrant or represent that any license, either express or implied, is granted under any patent right, copyright, mask work right, or other intellectual property right relating to any combination, machine, or process in which TI components or services are used. Information published by TI regarding third-party products or services does not constitute a license to use such products or services or a warranty or endorsement thereof. Use of such information may require a license from a third party under the patents or other intellectual property of the third party, or a license from TI under the patents or other intellectual property of TI.

Reproduction of significant portions of TI information in TI data books or data sheets is permissible only if reproduction is without alteration and is accompanied by all associated warranties, conditions, limitations, and notices. TI is not responsible or liable for such altered documentation. Information of third parties may be subject to additional restrictions.

Resale of TI components or services with statements different from or beyond the parameters stated by TI for that component or service voids all express and any implied warranties for the associated TI component or service and is an unfair and deceptive business practice. TI is not responsible or liable for any such statements.

Buyer acknowledges and agrees that it is solely responsible for compliance with all legal, regulatory and safety-related requirements concerning its products, and any use of TI components in its applications, notwithstanding any applications-related information or support that may be provided by TI. Buyer represents and agrees that it has all the necessary expertise to create and implement safeguards which anticipate dangerous consequences of failures, monitor failures and their consequences, lessen the likelihood of failures that might cause harm and take appropriate remedial actions. Buyer will fully indemnify TI and its representatives against any damages arising out of the use of any TI components in safety-critical applications.

In some cases, TI components may be promoted specifically to facilitate safety-related applications. With such components, TI's goal is to help enable customers to design and create their own end-product solutions that meet applicable functional safety standards and requirements. Nonetheless, such components are subject to these terms.

No TI components are authorized for use in FDA Class III (or similar life-critical medical equipment) unless authorized officers of the parties have executed a special agreement specifically governing such use.

Only those TI components which TI has specifically designated as military grade or "enhanced plastic" are designed and intended for use in military/aerospace applications or environments. Buyer acknowledges and agrees that any military or aerospace use of TI components which have **not** been so designated is solely at the Buyer's risk, and that Buyer is solely responsible for compliance with all legal and regulatory requirements in connection with such use.

TI has specifically designated certain components as meeting ISO/TS16949 requirements, mainly for automotive use. In any case of use of non-designated products, TI will not be responsible for any failure to meet ISO/TS16949.

### Products

Audio	<a href="http://www.ti.com/audio">www.ti.com/audio</a>
Amplifiers	<a href="http://amplifier.ti.com">amplifier.ti.com</a>
Data Converters	<a href="http://dataconverter.ti.com">dataconverter.ti.com</a>
DLP® Products	<a href="http://www.dlp.com">www.dlp.com</a>
DSP	<a href="http://dsp.ti.com">dsp.ti.com</a>
Clocks and Timers	<a href="http://www.ti.com/clocks">www.ti.com/clocks</a>
Interface	<a href="http://interface.ti.com">interface.ti.com</a>
Logic	<a href="http://logic.ti.com">logic.ti.com</a>
Power Mgmt	<a href="http://power.ti.com">power.ti.com</a>
Microcontrollers	<a href="http://microcontroller.ti.com">microcontroller.ti.com</a>
RFID	<a href="http://www.ti-rfid.com">www.ti-rfid.com</a>
OMAP Applications Processors	<a href="http://www.ti.com/omap">www.ti.com/omap</a>
Wireless Connectivity	<a href="http://www.ti.com/wirelessconnectivity">www.ti.com/wirelessconnectivity</a>

### Applications

Automotive and Transportation	<a href="http://www.ti.com/automotive">www.ti.com/automotive</a>
Communications and Telecom	<a href="http://www.ti.com/communications">www.ti.com/communications</a>
Computers and Peripherals	<a href="http://www.ti.com/computers">www.ti.com/computers</a>
Consumer Electronics	<a href="http://www.ti.com/consumer-apps">www.ti.com/consumer-apps</a>
Energy and Lighting	<a href="http://www.ti.com/energy">www.ti.com/energy</a>
Industrial	<a href="http://www.ti.com/industrial">www.ti.com/industrial</a>
Medical	<a href="http://www.ti.com/medical">www.ti.com/medical</a>
Security	<a href="http://www.ti.com/security">www.ti.com/security</a>
Space, Avionics and Defense	<a href="http://www.ti.com/space-avionics-defense">www.ti.com/space-avionics-defense</a>
Video and Imaging	<a href="http://www.ti.com/video">www.ti.com/video</a>

### TI E2E Community

[e2e.ti.com](http://e2e.ti.com)