

## 2x2 LVDS CROSSPOINT SWITCH

### FEATURES

- High Speed (>1000 Mbps) Upgrade for DS90CP22 2x2 LVDS Crosspoint Switch
- LVPECL Crosspoint Switch Available in SN65LVCP23
- Low-Jitter Fully Differential Data Path
- 50 ps (Typ), of Peak-to-Peak Jitter With PRBS =  $2^{23}-1$  Pattern
- Less Than 200 mW (Typ), 300 mW (Max) Total Power Dissipation
- Output (Channel-to-Channel) Skew Is 10 ps (Typ), 50 ps (Max)
- Configurable as 2:1 Mux, 1:2 Demux, Repeater or 1:2 Signal Splitter
- Inputs Accept LVDS, LVPECL, and CML Signals
- Fast Switch Time of 1.7 ns (Typ)
- Fast Propagation Delay of 0.65 ns (Typ)
- 16 Lead SOIC and TSSOP Packages
- Inter-Operates With TIA/EIA-644-A LVDS Standard
- Operating Temperature:  $-40^{\circ}\text{C}$  to  $85^{\circ}\text{C}$

### APPLICATIONS

- Base Stations
- Add/Drop Muxes
- Protection Switching for Serial Backplanes
- Network Switches/Routers
- Optical Networking Line Cards/Switches
- Clock Distribution

### DESCRIPTION

The SN65LVCP22 is a 2x2 crosspoint switch providing greater than 1000 Mbps operation for each path. The dual channels incorporate wide common-mode (0 V to 4 V) receivers, allowing for the receipt of LVDS, LVPECL, and CML signals. The dual outputs are LVDS drivers to provide low-power, low-EMI, high-speed operation. The SN65LVCP22 provides a single device supporting 2:2 buffering (repeating), 1:2 splitting, 2:1 multiplexing, 2x2 switching, and LVPECL/CML to LVDS level translation on each channel. The flexible operation of the SN65LVCP22 provides a single device to support the redundant serial bus transmission needs (working and protection switching cards) of fault-tolerant switch systems found in optical networking, wireless infrastructure, and data communications systems. TI offers additional gigabit repeater/ translator and crosspoint products in the SN65LVDS100 and SN65LVDS122.

The SN65LVCP22 uses a fully differential data path to ensure low-noise generation, fast switching times, low pulse width distortion, and low jitter. Output channel-to-channel skew is less than 10 ps (typ) and 50 ps (max) to ensure accurate alignment of outputs in all applications. Both SOIC and TSSOP package options are available to allow easy upgrade for existing solutions, and board area savings where space is critical.

#### OUTPUTS OPERATING SIMULTANEOUSLY

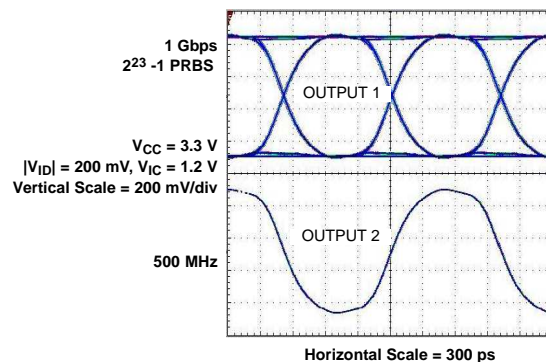

Please be aware that an important notice concerning availability, standard warranty, and use in critical applications of Texas Instruments semiconductor products and disclaimers thereto appears at the end of this data sheet.



These devices have limited built-in ESD protection. The leads should be shorted together or the device placed in conductive foam during storage or handling to prevent electrostatic damage to the MOS gates.

**ORDERING INFORMATION**

PACKAGE DESIGNATOR	PART NUMBER <sup>(1)</sup>	SYMBOLIZATION
SOIC	SN65LVCP22D	LVCP22
TSSOP	SN65LVCP22PW	LVCP22

(1) Add the suffix R for taped and reeled carrier

**PACKAGE DISSIPATION RATINGS**

PACKAGE	CIRCUIT BOARD MODEL	T <sub>A</sub> ≤ 25°C POWER RATING	DERATING FACTOR <sup>(1)</sup> ABOVE T <sub>A</sub> = 25°C	T <sub>A</sub> = 85°C POWER RATING
SOIC (D)	High-K <sup>(2)</sup>	1361 mW	13.9 mW/°C	544 mW
TSSOP (PW)	High-K <sup>(2)</sup>	1074 mW	10.7 mW/°C	430 mW

(1) This is the inverse of the junction-to-ambient thermal resistance when board-mounted and with no air flow.

(2) In accordance with the High-K thermal metric definitions of EIA/JESD51-7.

**THERMAL CHARACTERISTICS**

PARAMETER		TEST CONDITIONS		VALUE	UNITS
θ <sub>JB</sub>	Junction-to-board thermal resistance	D		11.2	°C/W
		PW		18.4	
θ <sub>JC</sub>	Junction-to-case thermal resistance	D		23.7	°C/W
		PW		16.0	
P <sub>D</sub>	Device power dissipation	Typical	V <sub>CC</sub> = 3.3 V, T <sub>A</sub> = 25°C, 1 Gbps	198	mW
		Maximum	V <sub>CC</sub> = 3.6 V, T <sub>A</sub> = 85°C, 1 Gbps	313	

**FUNCTION TABLE**

SEL0	SEL1	OUT0	OUT1	FUNCTION
0	0	IN0	IN0	1:2 Splitter
0	1	IN0	IN1	Repeater
1	0	IN1	IN0	Switch
1	1	IN1	IN1	1:2 Splitter

**FUNCTIONAL BLOCK DIAGRAM**

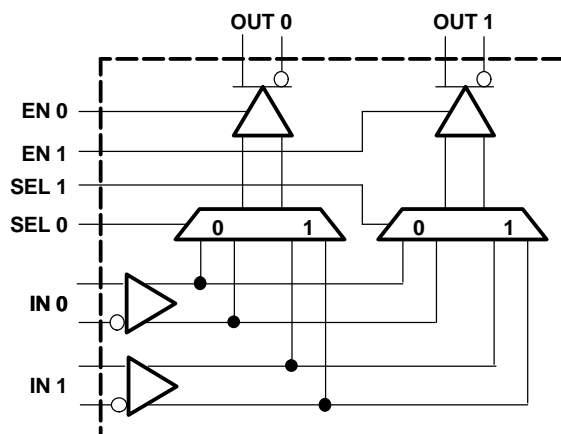

## EQUIVALENT INPUT AND OUTPUT SCHEMATIC DIAGRAMS

### INPUTS

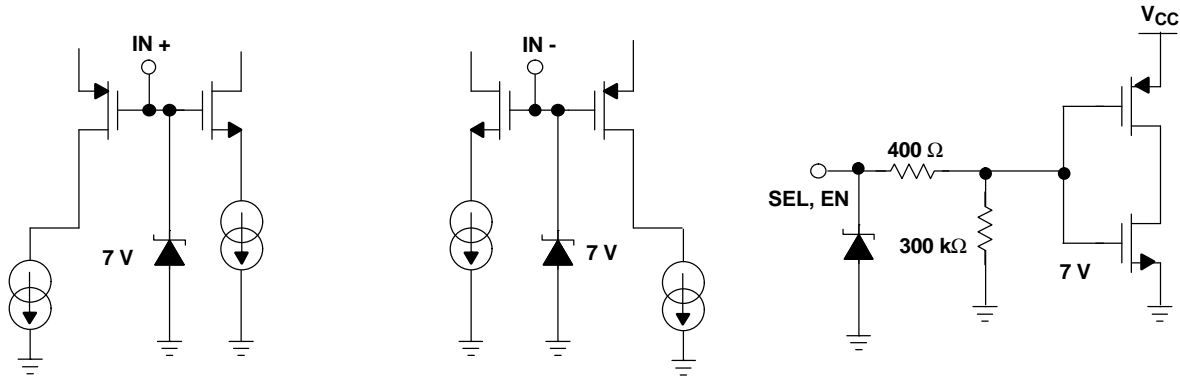

### OUTPUTS

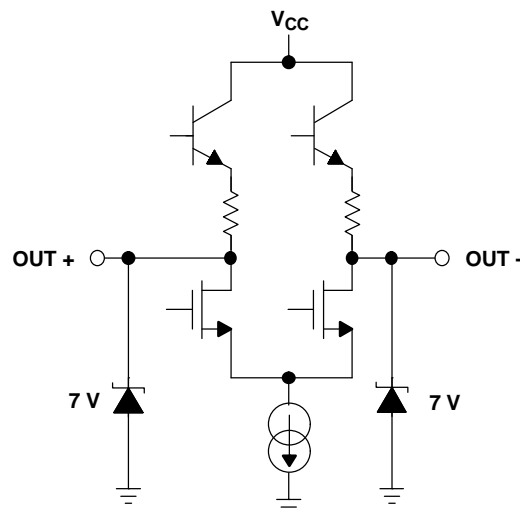

## ABSOLUTE MAXIMUM RATINGS

over operating free-air temperature range unless otherwise noted<sup>(1)</sup>

		UNITS
Supply voltage <sup>(2)</sup> range, $V_{CC}$		–0.5 V to 4 V
CMOS/TTL input voltage (ENO, EN1, SEL0, SEL1)		–0.5 V to 4 V
LVDS receiver input voltage (IN+, IN–)		–0.7 V to 4.3 V
LVDS driver output voltage (OUT+, OUT–)		–0.5 V to 4 V
LVDS output short circuit current		Continuous
Storage temperature range		–65°C to 125°C
Lead temperature 1,6 mm (1/16 inch) from case for 10 seconds		235°C
Continuous power dissipation		See Dissipation Rating Table
Electrostatic discharge	Human body model <sup>(3)</sup>	All pins ±5 kV
	Charged-device mode <sup>(4)</sup>	All pins ±500 V

- (1) Stresses beyond those listed under *absolute maximum ratings* may cause permanent damage to the device. These are stress ratings only, and functional operation of the device at these or any other conditions beyond those indicated under *recommended operating conditions* is not implied. Exposure to absolute-maximum-rated conditions for extended periods may affect device reliability.
- (2) All voltage values, except differential I/O bus voltages, are with respect to network ground terminals.
- (3) Tested in accordance with JEDEC Standard 22, Test Method A114-A.
- (4) Tested in accordance with JEDEC Standard 22, Test Method C101.

**RECOMMENDED OPERATING CONDITIONS**

	MIN	NOM	MAX	UNIT
Supply voltage, $V_{CC}$	3	3.3	3.6	V
Receiver input voltage	0		4	V
Junction temperature			125	°C
Operating free-air temperature, $T_A^{(1)}$	-40		85	°C
Magnitude of differential input voltage $ V_{ID} $	0.1		3	V

(1) Maximum free-air temperature operation is allowed as long as the device maximum junction temperature is not exceeded.

**INPUT ELECTRICAL CHARACTERISTICS**

over recommended operating conditions unless otherwise noted

PARAMETER	TEST CONDITIONS	MIN	TYP <sup>(1)</sup>	MAX	UNIT
<b>CMOS/TTL DC SPECIFICATIONS (EN0, EN1, SEL0, SEL1)</b>					
$V_{IH}$ High-level input voltage		2		$V_{CC}$	V
$V_{IL}$ Low-level input voltage		GND		0.8	V
$I_{IH}$ High-level input current	$V_{IN} = 3.6\text{ V or }2.0\text{ V}, V_{CC} = 3.6\text{ V}$		±3	±20	µA
$I_{IL}$ Low-level input current	$V_{IN} = 0.0\text{ V or }0.8\text{ V}, V_{CC} = 3.6\text{ V}$		±1	±10	µA
$V_{CL}$ Input clamp voltage	$I_{CL} = -18\text{ mA}$		-0.8	-1.5	V
<b>LVDS OUTPUT SPECIFICATIONS (OUT0, OUT1)</b>					
$ V_{OD} $ Differential output voltage	$R_L = 75\ \Omega$ , See <a href="#">Figure 2</a>	270	365	475	mV
	$R_L = 75\ \Omega, V_{CC} = 3.3\text{ V}, T_A = 25^\circ\text{C}$ , See <a href="#">Figure 2</a>	285	365	440	
$\Delta V_{OD} $ Change in differential output voltage magnitude between logic states	$V_{ID} = \pm 100\text{ mV}$ , See <a href="#">Figure 2</a>	-25		25	mV
$V_{OS}$ Steady-state offset voltage	See <a href="#">Figure 3</a>	1	1.2	1.45	V
$\Delta V_{OS}$ Change in steady-state offset voltage between logic states	See <a href="#">Figure 3</a>	-25		25	mV
$V_{OC(PP)}$ Peak-to-peak common-mode output voltage	See <a href="#">Figure 3</a>		50	150	mV
$I_{OZ}$ High-impedance output current	$V_{OUT} = \text{GND or } V_{CC}$			±10	µA
$I_{OFF}$ Power-off leakage current	$V_{CC} = 0\text{ V}, 1.5\text{ V}; V_{OUT} = 3.6\text{ V or GND}$			±10	µA
$I_{OS}$ Output short-circuit current	$V_{OUT+}$ or $V_{OUT-} = 0\text{ V}$			-24	mA
$I_{OSB}$ Both outputs short-circuit current	$V_{OUT+}$ and $V_{OUT-} = 0\text{ V}$	-12		12	mA
$C_O$ Differential output capacitance	$V_I = 0.4 \sin(4E6\pi t) + 0.5\text{ V}$		3		pF
<b>LVDS RECEIVER DC SPECIFICATIONS (IN0, IN1)</b>					
$V_{TH}$ Positive-going differential input voltage threshold	See <a href="#">Figure 1</a> and <a href="#">Table 1</a>			100	mV
$V_{TL}$ Negative-going differential input voltage threshold	See <a href="#">Figure 1</a> and <a href="#">Table 1</a>	-100			mV
$V_{ID(HYS)}$ Differential input voltage hysteresis			25		mV
$V_{CMR}$ Common-mode voltage range	$V_{ID} = 100\text{ mV}, V_{CC} = 3.0\text{ V to }3.6\text{ V}$	0.05		3.95	V
$I_{IN}$ Input current	$V_{IN} = 4\text{ V}, V_{CC} = 3.6\text{ V or }0.0$		±1	±10	µA
	$V_{IN} = 0\text{ V}, V_{CC} = 3.6\text{ V or }0.0$		±1	±10	
$C_{IN}$ Differential input capacitance	$V_I = 0.4 \sin(4E6\pi t) + 0.5\text{ V}$		3		pF
<b>SUPPLY CURRENT</b>					
$I_{CCD}$ Total supply current	$R_L = 75\ \Omega, C_L = 5\text{ pF}, 500\text{ MHz (1000 Mbps)}, EN0=EN1=High$		60	87	mA
$I_{CCZ}$ 3-state supply current	$EN0 = EN1 = Low$		25	35	mA

(1) All typical values are at 25°C and with a 3.3-V supply.

## SWITCHING CHARACTERISTICS

over recommended operating conditions unless otherwise noted

parameter	TEST CONDITIONS	MIN	TYP	MAX	UNIT
$t_{SET}$ Input to SEL setup time	See Figure 6	1	0.5		ns
$t_{HOLD}$ Input to SEL hold time	See Figure 6	1.1	0.5		ns
$t_{SWITCH}$ SEL to switched output	See Figure 6		1.7	2.5	ns
$t_{PHZ}$ Disable time, high-level-to-high-impedance	See Figure 5		2	4	ns
$t_{PLZ}$ Disable time, low-level-to-high-impedance	See Figure 5		2	4	ns
$t_{PZH}$ Enable time, high-impedance -to-high-level output	See Figure 5		2	4	ns
$t_{PZL}$ Enable time, high-impedance-to-low-level output	See Figure 5		2	4	ns
$t_{LHT}$ Differential output signal rise time (20%-80%) <sup>(1)</sup>	$C_L = 5$ pF, See Figure 4	150	280	450	ps
$t_{HLT}$ Differential output signal fall time (20%-80%) <sup>(1)</sup>	$C_L = 5$ pF, See Figure 4	150	280	450	ps
$t_{JIT}$ Added peak-to-peak jitter	$V_{ID} = 200$ mV, 50% duty cycle, $V_{CM} = 1.2$ V, 500 MHz, $C_L = 5$ pF		20	40	ps
	$V_{ID} = 200$ mV, PRBS = 2 <sup>23</sup> -1 data pattern, $V_{CM} = 1.2$ V at 1000 Mbps, $C_L = 5$ pF		50	105	ps
$t_{Jrms}$ Added random jitter (rms)	$V_{ID} = 200$ mV, 50% duty cycle, $V_{CM} = 1.2$ V at 500 MHz, $C_L = 5$ pF		1.1	1.8	ps <sub>RMS</sub>
$t_{PLHD}$ Propagation delay time, low-to-high-level output <sup>(1)</sup>		400	650	1000	ps
$t_{PHLD}$ Propagation delay time, high-to-low-level output <sup>(1)</sup>		400	650	1000	ps
$t_{skew}$ Pulse skew ( $ t_{PLHD} - t_{PHLD} $ ) <sup>(2)</sup>	$C_L = 5$ pF, See Figure 4		20	100	ps
$t_{CCS}$ Output channel-to-channel skew, splitter mode	$C_L = 5$ pF, See Figure 4		10	50	ps
$f_{MAX}$ Maximum operating frequency <sup>(3)</sup>		1			GHz

(1) Input:  $V_{IC} = 1.2$  V,  $V_{ID} = 200$  mV, 50% duty cycle, 1 MHz,  $t_r/t_f = 500$  ps

(2)  $t_{skew}$  is the magnitude of the time difference between the  $t_{PLHD}$  and  $t_{PHLD}$  of any output of a single device.

(3) Signal generator conditions: 50% duty cycle,  $t_r$  or  $t_f \leq 100$  ps (10% to 90%), transmitter output criteria: duty cycle = 45% to 55%  $V_{OD} \geq 300$  mV.

## PIN ASSIGNMENTS

D or PW PACKAGE  
(TOP VIEW)

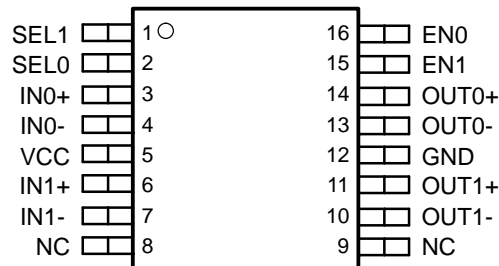

NC - No internal connection

PARAMETER MEASUREMENT INFORMATION

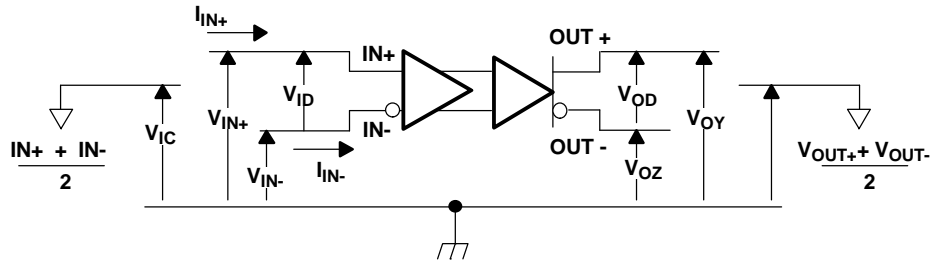

Figure 1. Voltage and Current Definitions

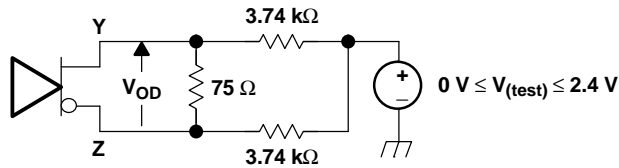
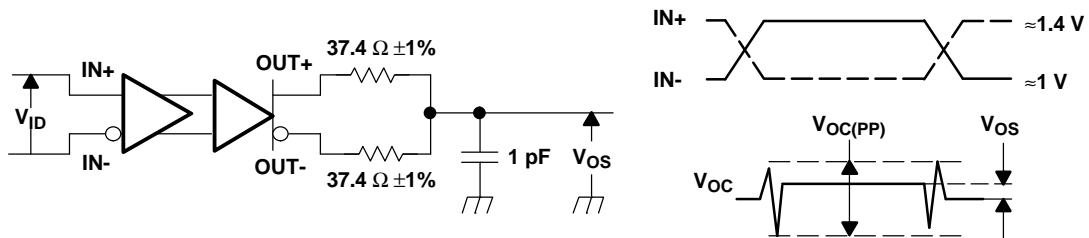

Figure 2. Differential Output Voltage ( $V_{OD}$ ) Test Circuit



NOTE: All input pulses are supplied by a generator having the following characteristics:  $t_r$  or  $t_f \leq 1$  ns, pulse-repetition rate (PRR) = 0.5 Mpps, pulse width =  $500 \pm 10$  ns;  $R_L = 100 \Omega$ ;  $C_L$  includes instrumentation and fixture capacitance within 0,06 mm of the D.U.T.; the measurement of  $V_{OC(PP)}$  is made on test equipment with a  $-3$  dB bandwidth of at least 300 MHz.

Figure 3. Test Circuit and Definitions for the Driver Common-Mode Output Voltage

PARAMETER MEASUREMENT INFORMATION (continued)

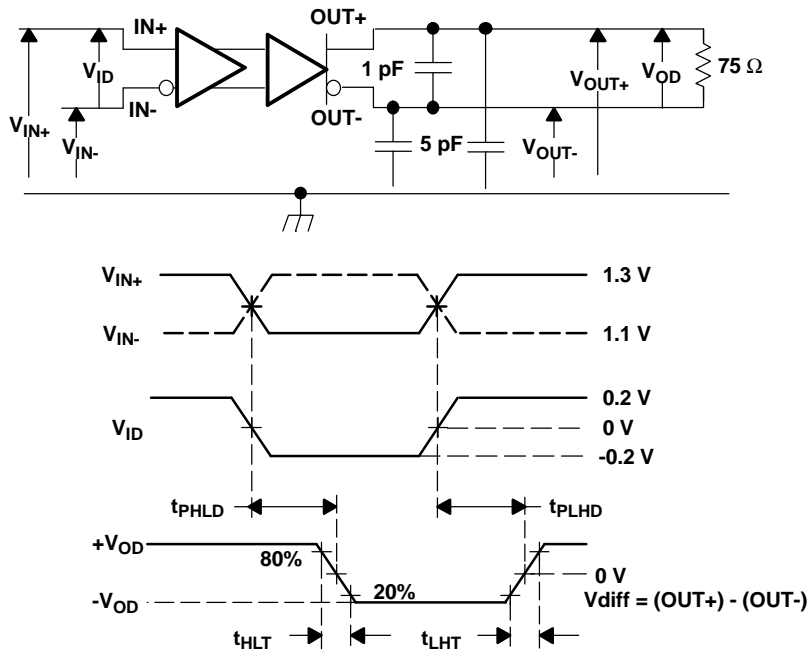

NOTE: All input pulses are supplied by a generator having the following characteristics:  $t_r$  or  $t_f \leq .25$  ns, pulse-repetition rate (PRR) = 0.5 Mpps, pulse width =  $500 \pm 10$  ns.  $C_L$  includes instrumentation and fixture capacitance within 0,06 mm of the D.U.T.

Figure 4. Timing Test Circuit and Waveforms

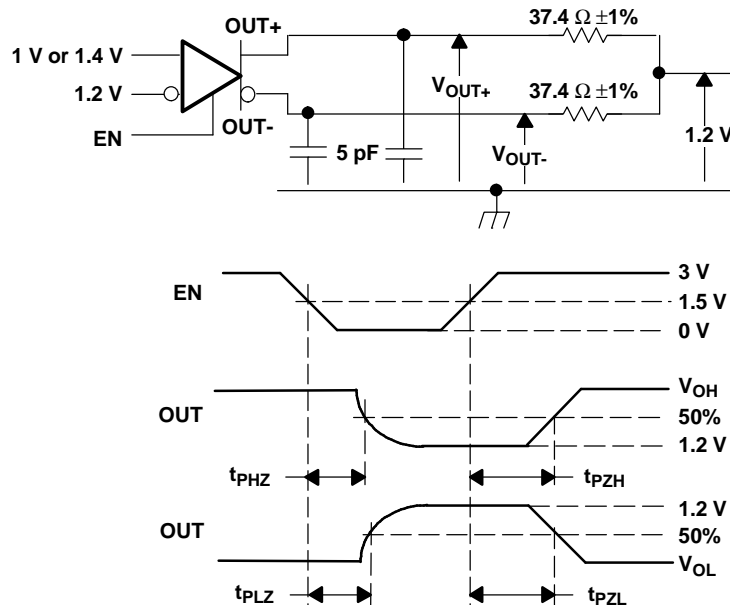

NOTE: All input pulses are supplied by a generator having the following characteristics:  $t_r$  or  $t_f \leq 1$  ns, pulse-repetition rate (PRR) = 0.5 Mpps, pulse width =  $500 \pm 10$  ns.  $C_L$  includes instrumentation and fixture capacitance within 0,06 mm of the D.U.T.

Figure 5. Enable and Disable Time Circuit and Definitions

**Table 1. Receiver Input Voltage Threshold Test**

APPLIED VOLTAGES		RESULTING DIFFERENTIAL INPUT VOLTAGE	RESULTING COMMON- MODE INPUT VOLTAGE	OUTPUT <sup>(1)</sup>
$V_{IA}$	$V_{IB}$	$V_{ID}$	$V_{IC}$	
1.25 V	1.15 V	100 mV	1.2 V	H
1.15 V	1.25 V	–100 mV	1.2 V	L
4.0 V	3.9 V	100 mV	3.95 V	H
3.9 V	4.0 V	–100 mV	3.95 V	L
0.1 V	0.0 V	100 mV	0.05 V	H
0.0 V	0.1 V	–100 mV	0.05 V	L
1.7 V	0.7 V	1000 mV	1.2 V	H
0.7 V	1.7 V	–1000 mV	1.2 V	L
4.0 V	3.0 V	1000 mV	3.5 V	H
3.0 V	4.0 V	–1000 mV	3.5 V	L
1.0 V	0.0 V	1000 mV	0.5 V	H
0.0 V	1.0 V	–1000 mV	0.5 V	L

(1) H = high level, L = low level

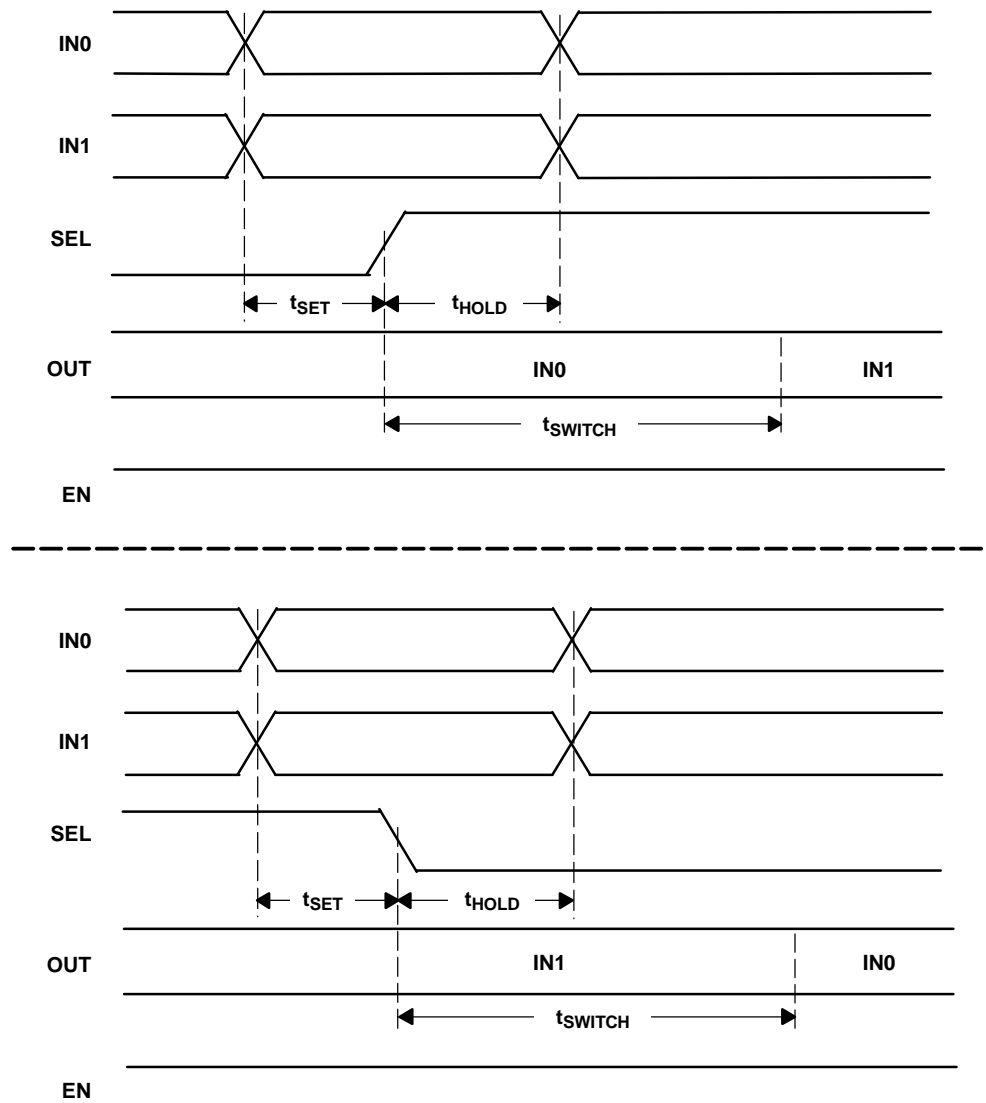

NOTE:  $t_{SET}$  and  $t_{HOLD}$  times specify that data must be in a stable state before and after mux control switches.

**Figure 6. Input to Select for Both Rising and Falling Edge Setup and Hold Times**

TYPICAL CHARACTERISTICS

DIFFERENTIAL OUTPUT VOLTAGE  
VS  
RESISTIVE LOAD

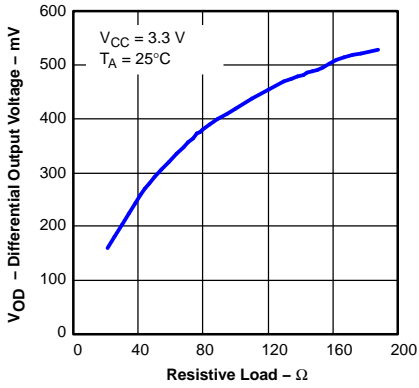

Figure 7.

SUPPLY CURRENT  
VS  
FREQUENCY

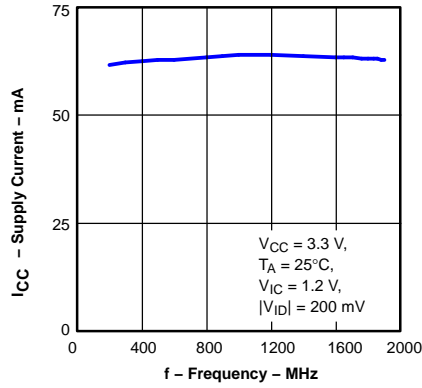

Figure 8.

PROPAGATION DELAY TIME  
VS  
FREE-AIR TEMPERATURE

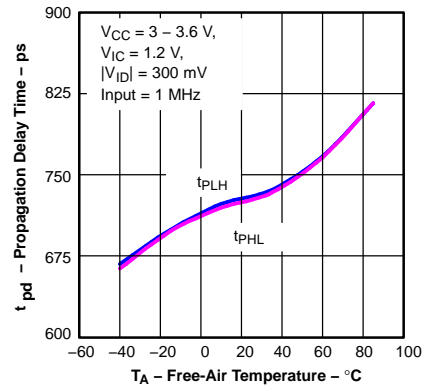

Figure 9.

PEAK-TO-PEAK JITTER  
VS  
FREQUENCY

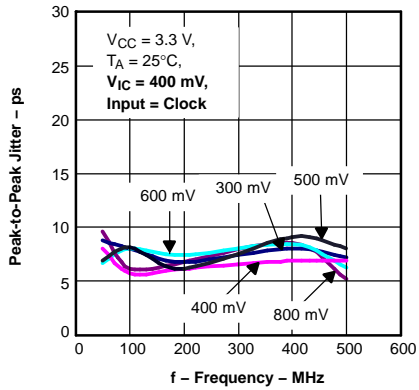

Figure 10.

PEAK-TO-PEAK JITTER  
VS  
DATA RATE

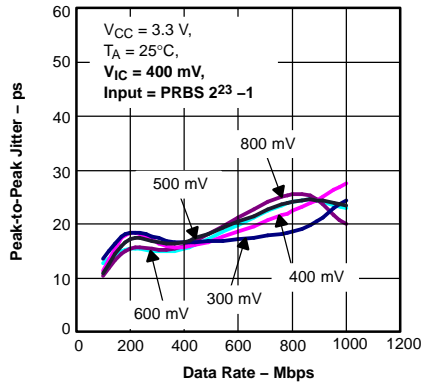

Figure 11.

PEAK-TO-PEAK JITTER  
VS  
FREQUENCY

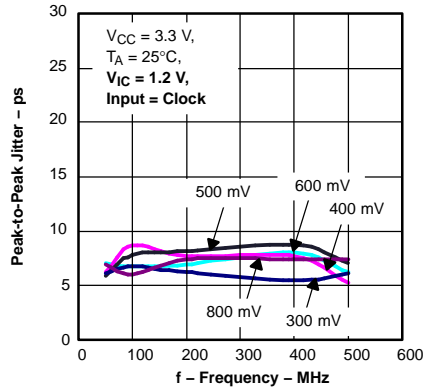

Figure 12.

PEAK-TO-PEAK JITTER  
VS  
DATA RATE

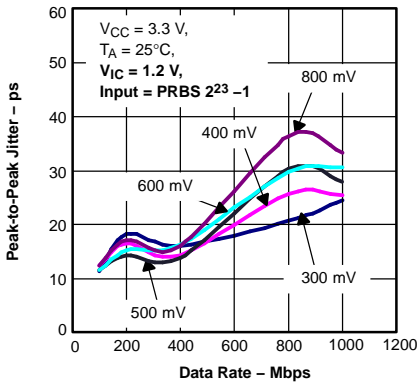

Figure 13.

PEAK-TO-PEAK JITTER  
VS  
FREQUENCY

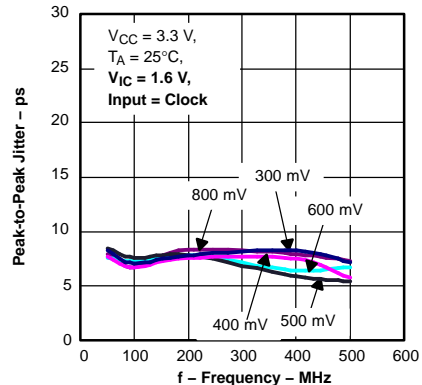

Figure 14.

PEAK-TO-PEAK JITTER  
VS  
DATA RATE

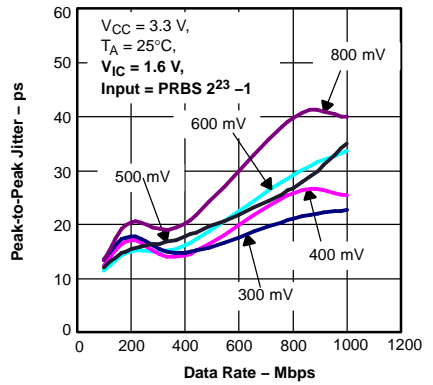

Figure 15.

TYPICAL CHARACTERISTICS (continued)

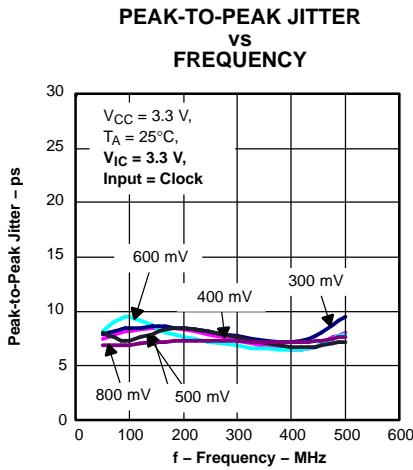

Figure 16.

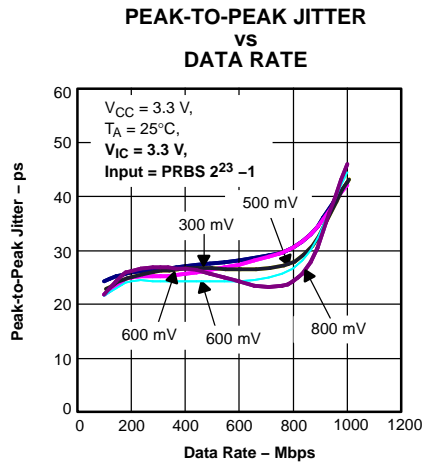

Figure 17.

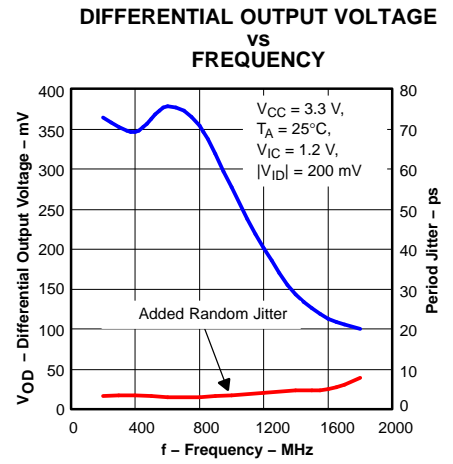

Figure 18.

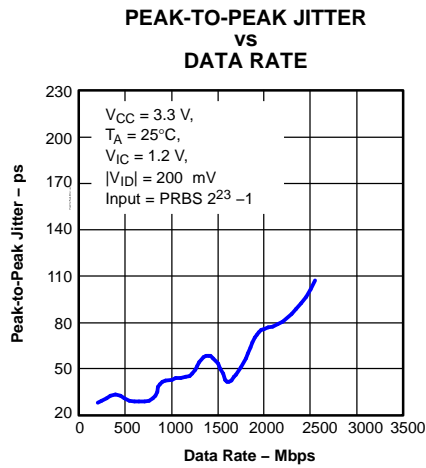

Figure 19.

APPLICATION INFORMATION

TYPICAL APPLICATION CIRCUITS (ECL, PECL, LVDS, etc.)

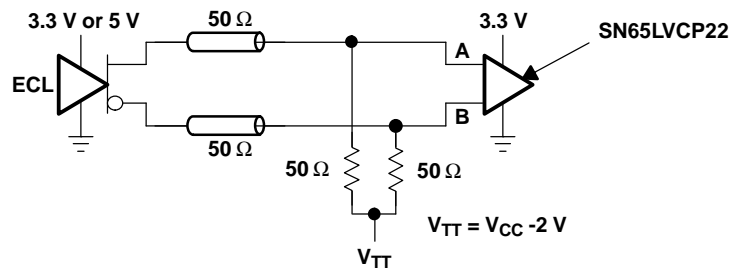

Figure 20. Low-Voltage Positive Emitter-Coupled Logic (LVPECL)

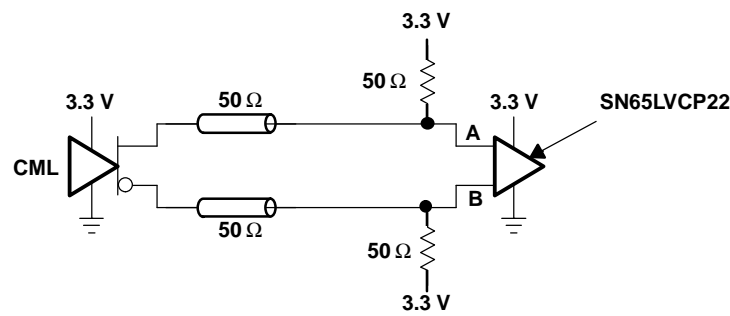

Figure 21. Current-Mode Logic (CML)

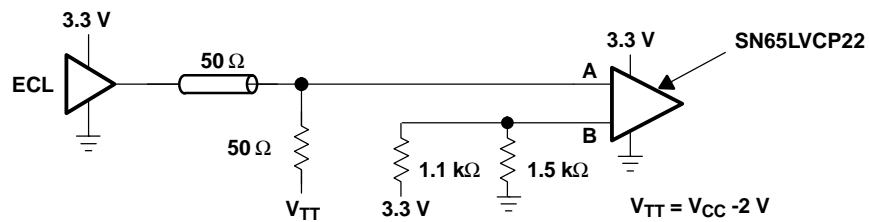

Figure 22. Single-Ended (LVPECL)

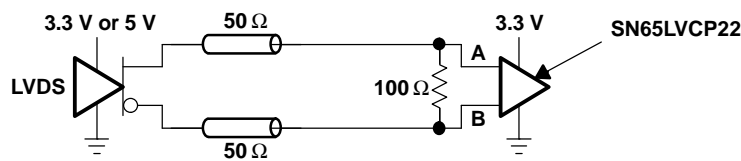
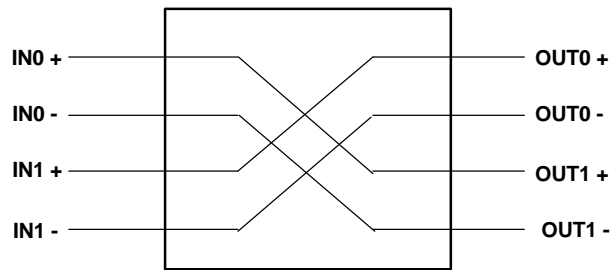
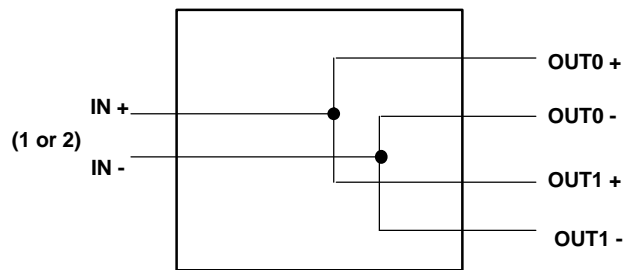

Figure 23. Low-Voltage Differential Signaling (LVDS)

**APPLICATION INFORMATION (continued)**



**Figure 24. 2 x 2 Crosspoint**



**Figure 25. 1:2 Splitter**



**Figure 26. Dual Repeater**

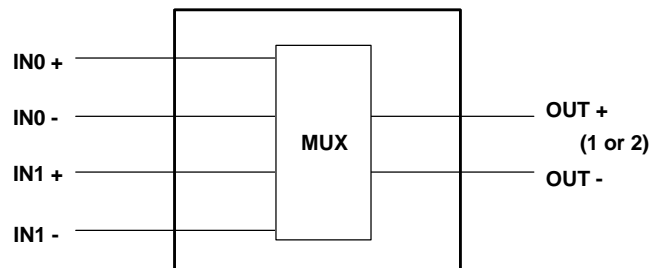

**Figure 27. 2:1 MUX**

**PACKAGING INFORMATION**

Orderable Device	Status (1)	Package Type	Package Drawing	Pins	Package Qty	Eco Plan (2)	Lead/Ball Finish (6)	MSL Peak Temp (3)	Op Temp (°C)	Device Marking (4/5)	Samples
SN65LVCP22D	ACTIVE	SOIC	D	16	40	Green (RoHS & no Sb/Br)	CU NIPDAU	Level-1-260C-UNLIM	-40 to 85	LVCP22	<a href="#">Samples</a>
SN65LVCP22DG4	ACTIVE	SOIC	D	16	40	Green (RoHS & no Sb/Br)	CU NIPDAU	Level-1-260C-UNLIM	-40 to 85	LVCP22	<a href="#">Samples</a>
SN65LVCP22DR	ACTIVE	SOIC	D	16	2500	Green (RoHS & no Sb/Br)	CU NIPDAU	Level-1-260C-UNLIM	-40 to 85	LVCP22	<a href="#">Samples</a>
SN65LVCP22PW	ACTIVE	TSSOP	PW	16	90	Green (RoHS & no Sb/Br)	CU NIPDAU	Level-1-260C-UNLIM	-40 to 85	LVCP22	<a href="#">Samples</a>
SN65LVCP22PWG4	ACTIVE	TSSOP	PW	16	90	Green (RoHS & no Sb/Br)	CU NIPDAU	Level-1-260C-UNLIM	-40 to 85	LVCP22	<a href="#">Samples</a>
SN65LVCP22PWR	ACTIVE	TSSOP	PW	16	2000	Green (RoHS & no Sb/Br)	CU NIPDAU	Level-1-260C-UNLIM	-40 to 85	LVCP22	<a href="#">Samples</a>

(1) The marketing status values are defined as follows:

**ACTIVE:** Product device recommended for new designs.

**LIFEBUY:** TI has announced that the device will be discontinued, and a lifetime-buy period is in effect.

**NRND:** Not recommended for new designs. Device is in production to support existing customers, but TI does not recommend using this part in a new design.

**PREVIEW:** Device has been announced but is not in production. Samples may or may not be available.

**OBSOLETE:** TI has discontinued the production of the device.

(2) Eco Plan - The planned eco-friendly classification: Pb-Free (RoHS), Pb-Free (RoHS Exempt), or Green (RoHS & no Sb/Br) - please check <http://www.ti.com/productcontent> for the latest availability information and additional product content details.

**TBD:** The Pb-Free/Green conversion plan has not been defined.

**Pb-Free (RoHS):** TI's terms "Lead-Free" or "Pb-Free" mean semiconductor products that are compatible with the current RoHS requirements for all 6 substances, including the requirement that lead not exceed 0.1% by weight in homogeneous materials. Where designed to be soldered at high temperatures, TI Pb-Free products are suitable for use in specified lead-free processes.

**Pb-Free (RoHS Exempt):** This component has a RoHS exemption for either 1) lead-based flip-chip solder bumps used between the die and package, or 2) lead-based die adhesive used between the die and leadframe. The component is otherwise considered Pb-Free (RoHS compatible) as defined above.

**Green (RoHS & no Sb/Br):** TI defines "Green" to mean Pb-Free (RoHS compatible), and free of Bromine (Br) and Antimony (Sb) based flame retardants (Br or Sb do not exceed 0.1% by weight in homogeneous material)

(3) MSL, Peak Temp. - The Moisture Sensitivity Level rating according to the JEDEC industry standard classifications, and peak solder temperature.

(4) There may be additional marking, which relates to the logo, the lot trace code information, or the environmental category on the device.

(5) Multiple Device Markings will be inside parentheses. Only one Device Marking contained in parentheses and separated by a "~" will appear on a device. If a line is indented then it is a continuation of the previous line and the two combined represent the entire Device Marking for that device.

<sup>(6)</sup> Lead/Ball Finish - Orderable Devices may have multiple material finish options. Finish options are separated by a vertical ruled line. Lead/Ball Finish values may wrap to two lines if the finish value exceeds the maximum column width.

**Important Information and Disclaimer:** The information provided on this page represents TI's knowledge and belief as of the date that it is provided. TI bases its knowledge and belief on information provided by third parties, and makes no representation or warranty as to the accuracy of such information. Efforts are underway to better integrate information from third parties. TI has taken and continues to take reasonable steps to provide representative and accurate information but may not have conducted destructive testing or chemical analysis on incoming materials and chemicals. TI and TI suppliers consider certain information to be proprietary, and thus CAS numbers and other limited information may not be available for release.

In no event shall TI's liability arising out of such information exceed the total purchase price of the TI part(s) at issue in this document sold by TI to Customer on an annual basis.

**TAPE AND REEL INFORMATION**
**REEL DIMENSIONS**

**TAPE DIMENSIONS**

A0	Dimension designed to accommodate the component width
B0	Dimension designed to accommodate the component length
K0	Dimension designed to accommodate the component thickness
W	Overall width of the carrier tape
P1	Pitch between successive cavity centers

**TAPE AND REEL INFORMATION**

\*All dimensions are nominal

Device	Package Type	Package Drawing	Pins	SPQ	Reel Diameter (mm)	Reel Width W1 (mm)	A0 (mm)	B0 (mm)	K0 (mm)	P1 (mm)	W (mm)	Pin1 Quadrant
SN65LVCP22DR	SOIC	D	16	2500	330.0	16.4	6.5	10.3	2.1	8.0	16.0	Q1
SN65LVCP22PWR	TSSOP	PW	16	2000	330.0	12.4	6.9	5.6	1.6	8.0	12.0	Q1

**TAPE AND REEL BOX DIMENSIONS**

\*All dimensions are nominal



Device	Package Type	Package Drawing	Pins	SPQ	Length (mm)	Width (mm)	Height (mm)
SN65LVCP22DR	SOIC	D	16	2500	367.0	367.0	38.0
SN65LVCP22PWR	TSSOP	PW	16	2000	367.0	367.0	35.0

D (R-PDSO-G16)

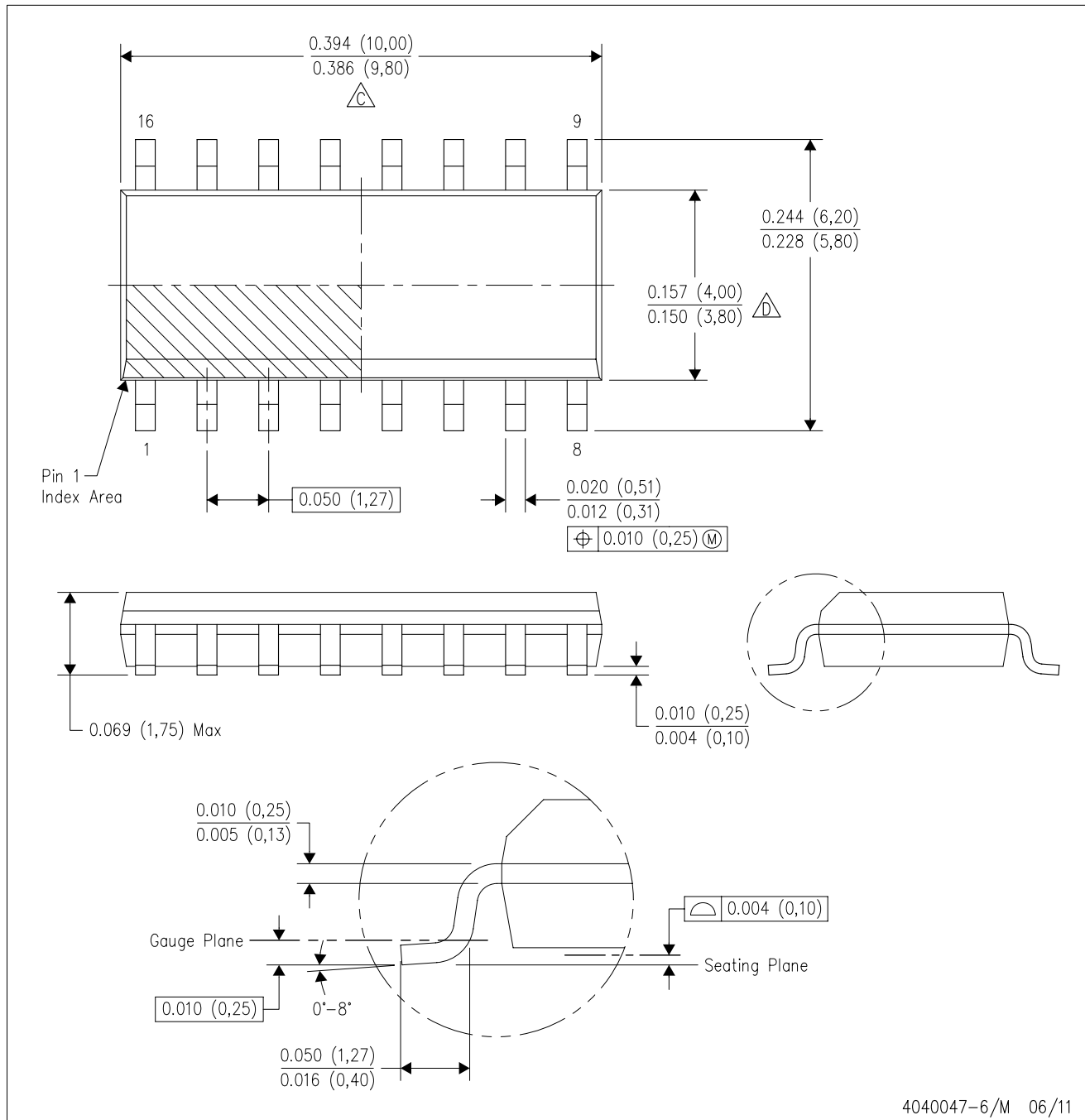
PLASTIC SMALL OUTLINE



4040047-6/M 06/11

- NOTES:
- A. All linear dimensions are in inches (millimeters).
  - B. This drawing is subject to change without notice.
  -  Body length does not include mold flash, protrusions, or gate burrs. Mold flash, protrusions, or gate burrs shall not exceed 0.006 (0,15) each side.
  -  Body width does not include interlead flash. Interlead flash shall not exceed 0.017 (0,43) each side.
  - E. Reference JEDEC MS-012 variation AC.

D (R-PDSO-G16)

PLASTIC SMALL OUTLINE



- NOTES:
- All linear dimensions are in millimeters.
  - This drawing is subject to change without notice.
  - Publication IPC-7351 is recommended for alternate designs.
  - Laser cutting apertures with trapezoidal walls and also rounding corners will offer better paste release. Customers should contact their board assembly site for stencil design recommendations. Refer to IPC-7525 for other stencil recommendations.
  - Customers should contact their board fabrication site for solder mask tolerances between and around signal pads.

PW (R-PDSO-G16)

PLASTIC SMALL OUTLINE

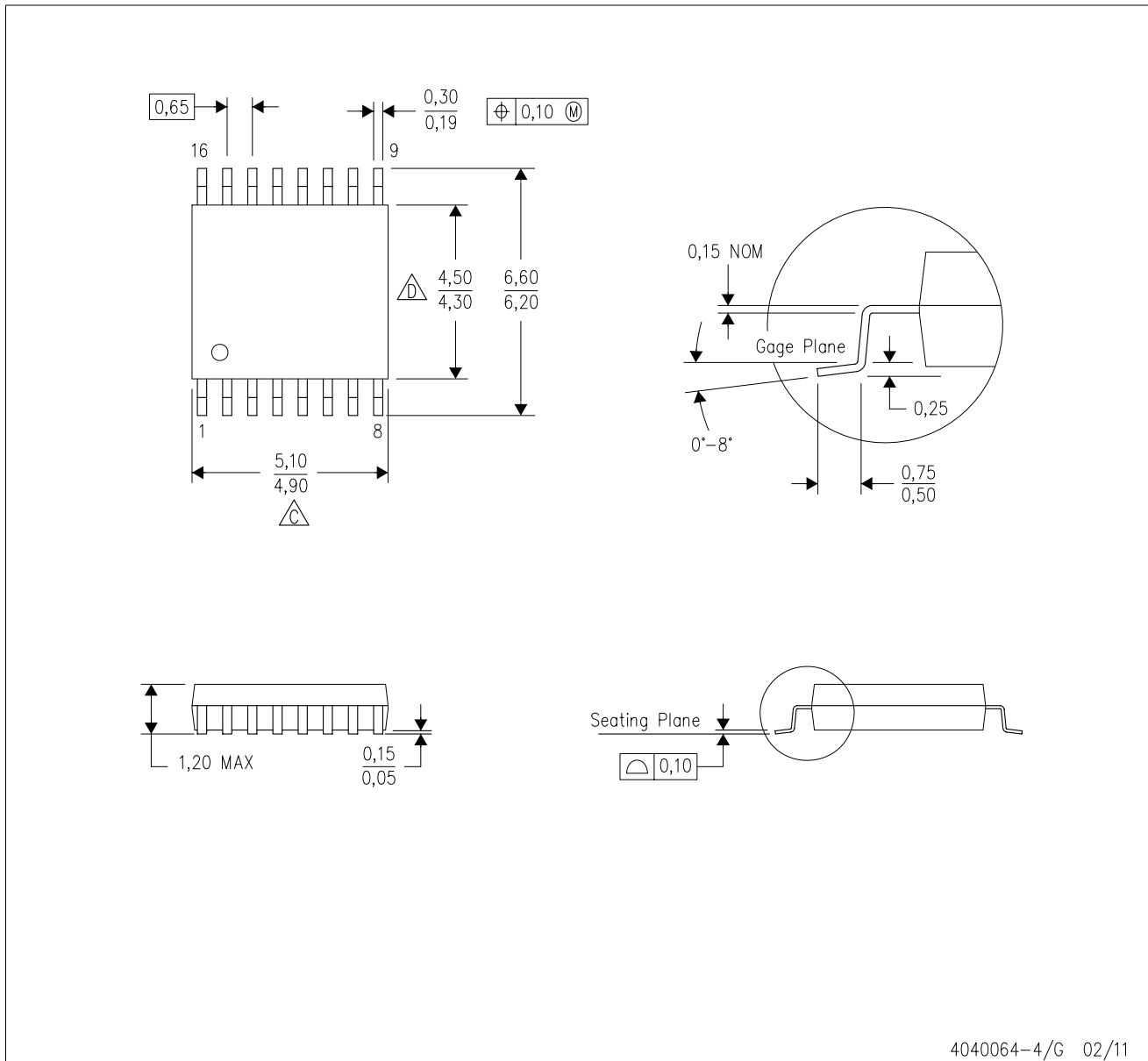

- NOTES:
- A. All linear dimensions are in millimeters. Dimensioning and tolerancing per ASME Y14.5M-1994.
  - B. This drawing is subject to change without notice.
  - C. Body length does not include mold flash, protrusions, or gate burrs. Mold flash, protrusions, or gate burrs shall not exceed 0,15 each side.
  - D. Body width does not include interlead flash. Interlead flash shall not exceed 0,25 each side.
  - E. Falls within JEDEC MO-153

PW (R-PDSO-G16)

PLASTIC SMALL OUTLINE

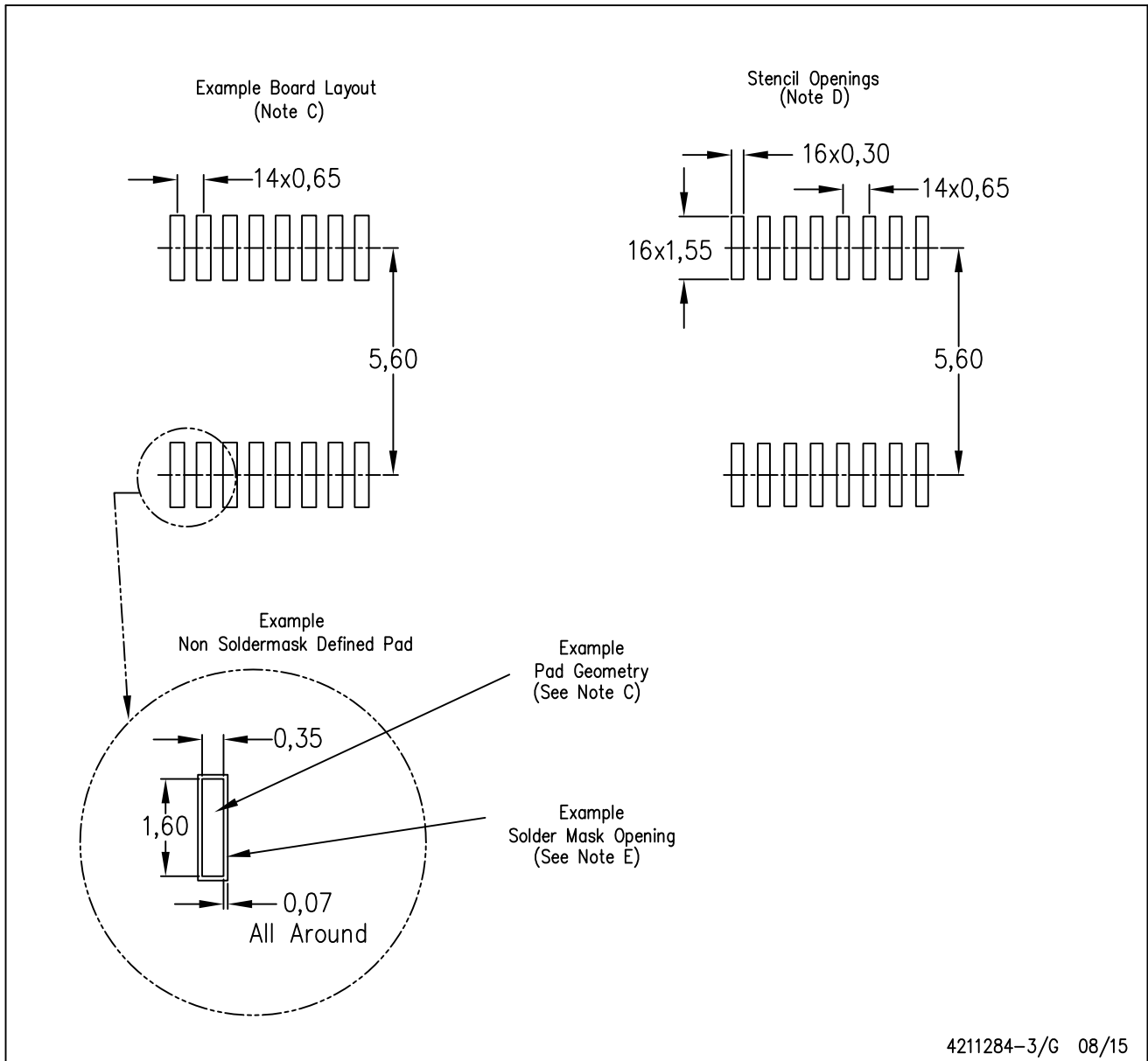

- NOTES:
- All linear dimensions are in millimeters.
  - This drawing is subject to change without notice.
  - Publication IPC-7351 is recommended for alternate designs.
  - Laser cutting apertures with trapezoidal walls and also rounding corners will offer better paste release. Customers should contact their board assembly site for stencil design recommendations. Refer to IPC-7525 for other stencil recommendations.
  - Customers should contact their board fabrication site for solder mask tolerances between and around signal pads.

## IMPORTANT NOTICE

Texas Instruments Incorporated and its subsidiaries (TI) reserve the right to make corrections, enhancements, improvements and other changes to its semiconductor products and services per JESD46, latest issue, and to discontinue any product or service per JESD48, latest issue. Buyers should obtain the latest relevant information before placing orders and should verify that such information is current and complete. All semiconductor products (also referred to herein as "components") are sold subject to TI's terms and conditions of sale supplied at the time of order acknowledgment.

TI warrants performance of its components to the specifications applicable at the time of sale, in accordance with the warranty in TI's terms and conditions of sale of semiconductor products. Testing and other quality control techniques are used to the extent TI deems necessary to support this warranty. Except where mandated by applicable law, testing of all parameters of each component is not necessarily performed.

TI assumes no liability for applications assistance or the design of Buyers' products. Buyers are responsible for their products and applications using TI components. To minimize the risks associated with Buyers' products and applications, Buyers should provide adequate design and operating safeguards.

TI does not warrant or represent that any license, either express or implied, is granted under any patent right, copyright, mask work right, or other intellectual property right relating to any combination, machine, or process in which TI components or services are used. Information published by TI regarding third-party products or services does not constitute a license to use such products or services or a warranty or endorsement thereof. Use of such information may require a license from a third party under the patents or other intellectual property of the third party, or a license from TI under the patents or other intellectual property of TI.

Reproduction of significant portions of TI information in TI data books or data sheets is permissible only if reproduction is without alteration and is accompanied by all associated warranties, conditions, limitations, and notices. TI is not responsible or liable for such altered documentation. Information of third parties may be subject to additional restrictions.

Resale of TI components or services with statements different from or beyond the parameters stated by TI for that component or service voids all express and any implied warranties for the associated TI component or service and is an unfair and deceptive business practice. TI is not responsible or liable for any such statements.

Buyer acknowledges and agrees that it is solely responsible for compliance with all legal, regulatory and safety-related requirements concerning its products, and any use of TI components in its applications, notwithstanding any applications-related information or support that may be provided by TI. Buyer represents and agrees that it has all the necessary expertise to create and implement safeguards which anticipate dangerous consequences of failures, monitor failures and their consequences, lessen the likelihood of failures that might cause harm and take appropriate remedial actions. Buyer will fully indemnify TI and its representatives against any damages arising out of the use of any TI components in safety-critical applications.

In some cases, TI components may be promoted specifically to facilitate safety-related applications. With such components, TI's goal is to help enable customers to design and create their own end-product solutions that meet applicable functional safety standards and requirements. Nonetheless, such components are subject to these terms.

No TI components are authorized for use in FDA Class III (or similar life-critical medical equipment) unless authorized officers of the parties have executed a special agreement specifically governing such use.

Only those TI components which TI has specifically designated as military grade or "enhanced plastic" are designed and intended for use in military/aerospace applications or environments. Buyer acknowledges and agrees that any military or aerospace use of TI components which have **not** been so designated is solely at the Buyer's risk, and that Buyer is solely responsible for compliance with all legal and regulatory requirements in connection with such use.

TI has specifically designated certain components as meeting ISO/TS16949 requirements, mainly for automotive use. In any case of use of non-designated products, TI will not be responsible for any failure to meet ISO/TS16949.

### Products

Audio	<a href="http://www.ti.com/audio">www.ti.com/audio</a>
Amplifiers	<a href="http://amplifier.ti.com">amplifier.ti.com</a>
Data Converters	<a href="http://dataconverter.ti.com">dataconverter.ti.com</a>
DLP® Products	<a href="http://www.dlp.com">www.dlp.com</a>
DSP	<a href="http://dsp.ti.com">dsp.ti.com</a>
Clocks and Timers	<a href="http://www.ti.com/clocks">www.ti.com/clocks</a>
Interface	<a href="http://interface.ti.com">interface.ti.com</a>
Logic	<a href="http://logic.ti.com">logic.ti.com</a>
Power Mgmt	<a href="http://power.ti.com">power.ti.com</a>
Microcontrollers	<a href="http://microcontroller.ti.com">microcontroller.ti.com</a>
RFID	<a href="http://www.ti-rfid.com">www.ti-rfid.com</a>
OMAP Applications Processors	<a href="http://www.ti.com/omap">www.ti.com/omap</a>
Wireless Connectivity	<a href="http://www.ti.com/wirelessconnectivity">www.ti.com/wirelessconnectivity</a>

### Applications

Automotive and Transportation	<a href="http://www.ti.com/automotive">www.ti.com/automotive</a>
Communications and Telecom	<a href="http://www.ti.com/communications">www.ti.com/communications</a>
Computers and Peripherals	<a href="http://www.ti.com/computers">www.ti.com/computers</a>
Consumer Electronics	<a href="http://www.ti.com/consumer-apps">www.ti.com/consumer-apps</a>
Energy and Lighting	<a href="http://www.ti.com/energy">www.ti.com/energy</a>
Industrial	<a href="http://www.ti.com/industrial">www.ti.com/industrial</a>
Medical	<a href="http://www.ti.com/medical">www.ti.com/medical</a>
Security	<a href="http://www.ti.com/security">www.ti.com/security</a>
Space, Avionics and Defense	<a href="http://www.ti.com/space-avionics-defense">www.ti.com/space-avionics-defense</a>
Video and Imaging	<a href="http://www.ti.com/video">www.ti.com/video</a>

### TI E2E Community

[e2e.ti.com](http://e2e.ti.com)