

## HIGH-SPEED DIFFERENTIAL LINE DRIVERS AND RECEIVERS

### FEATURES

- **Low-Voltage Differential 50-Ω Line Drivers and Receivers**
- **Typical Full-Duplex Signaling Rates of 100 Mbps (See Table 1)**
- **Bus-Terminal ESD Exceeds 12 kV**
- **Operates From a Single 3.3-V Supply**
- **Low-Voltage Differential Signaling With Typical Output Voltages of 340 mV With a 50-Ω Load**
- **Valid Output With as Little as 50-mV Input Voltage Difference**
- **Propagation Delay Times**
  - Driver: 1.7 ns Typical
  - Receiver: 3.7 ns Typical
- **Power Dissipation at 200 MHz**
  - Driver: 50 mW Typical
  - Receiver: 60 mW Typical
- **LVTTTL Input Levels Are 5-V Tolerant**
- **Driver Is High Impedance When Disabled or With  $V_{CC} < 1.5$  V**
- **Receiver Has Open-Circuit Failsafe**

### DESCRIPTION

The SN65LVDM179, SN65LVDM180, SN65LVDM050, and SN65LVDM051 are differential line drivers and receivers that use low-voltage differential signaling (LVDS) to achieve high signaling rates. These circuits are similar to TIA/EIA-644 standard compliant devices (SN65LVDS) counterparts, except that the output current of the drivers is doubled. This modification provides a minimum differential output voltage magnitude of 247 mV across a 50-Ω load simulating two transmission lines in parallel. This allows having data buses with more than one driver or with two line termination resistors. The receivers detect a voltage difference of 50 mV with up to 1 V of ground potential difference between a transmitter and receiver.

The intended application of these devices and signaling techniques is point-to-point half duplex, baseband data transmission over a controlled impedance media of approximately 100 Ω characteristic impedance.

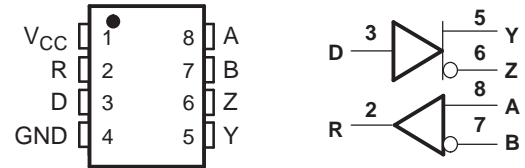
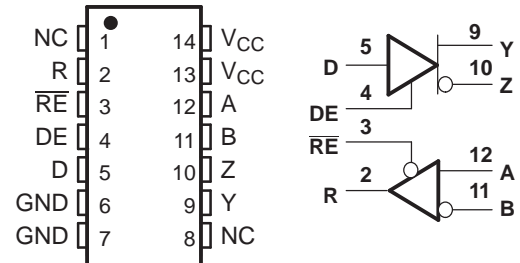
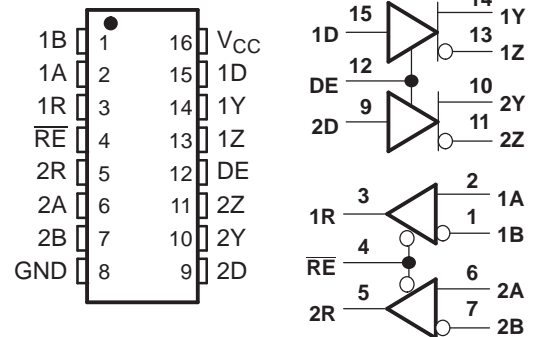
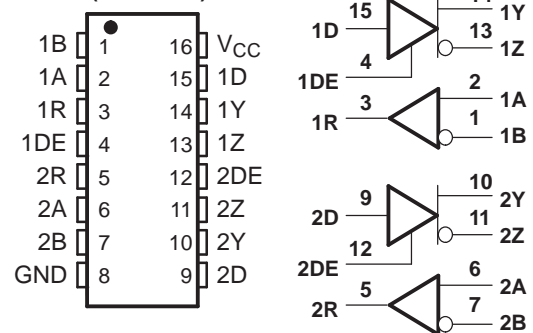
**SN65LVDM179D (Marked as DM179 or LVM179)**
**SN65LVDM179DGK (Marked as M79)**  
(TOP VIEW)

**SN65LVDM180D (Marked as LVDM180)**
**SN65LVDM180PW (Marked as LVDM180)**  
(TOP VIEW)

**SN65LVDM050D (Marked as LVDM050)**
**SN65LVDM050PW (Marked as LVDM050)**  
(TOP VIEW)

**SN65LVDM051D (Marked as LVDM051)**
**SN65LVDM051PW (Marked as LVDM051)**  
(TOP VIEW)

Please be aware that an important notice concerning availability, standard warranty, and use in critical applications of Texas Instruments semiconductor products and disclaimers thereto appears at the end of this data sheet.



These devices have limited built-in ESD protection. The leads should be shorted together or the device placed in conductive foam during storage or handling to prevent electrostatic damage to the MOS gates.

## DESCRIPTION (CONTINUED)

The transmission media may be printed-circuit board traces, backplanes, or cables. The ultimate rate and distance of data transfer is dependent upon the attenuation characteristics of the media, the noise coupling to the environment, and other application-specific characteristics.

The SN65LVDM179, SN65LVDM180, SN65LVDM050, and SN65LVDM051 are characterized for operation from  $-40^{\circ}\text{C}$  to  $85^{\circ}\text{C}$ .

**Table 1. Maximum Recommended Operating Speeds**

Part Number	All Buffers Active	Rx Buffer Only	Tx Buffer Only
SN65LVDM179	150 Mbps	150 Mbps	500 Mbps
SN65LVDM180	150 Mbps	150 Mbps	500 Mbps
SN65LVDM050	100 Mbps	100 Mbps	400 Mbps
SN65LVDM051	100 Mbps	100 Mbps	400 Mbps

## AVAILABLE OPTIONS

$T_A$	PACKAGE		
	SMALL OUTLINE (D)	SMALL OUTLINE (DGK)	SMALL OUTLINE (PW)
$-40^{\circ}\text{C}$ to $85^{\circ}\text{C}$	SN65LVDM050D	—	SN65LVDM050PW
	SN65LVDM051D	—	SN65LVDM051PW
	SN65LVDM179D	SN65LVDM179DGK	—
	SN65LVDM180D	—	SN65LVDM180PW

## FUNCTION TABLES

### SN65LVDM179 RECEIVER

INPUTS	OUTPUT <sup>(1)</sup>
$V_{ID} = V_A - V_B$	R
$V_{ID} \geq 50\text{ mV}$	H
$50\text{ mV} < V_{ID} < 50\text{ mV}$	?
$V_{ID} \leq -50\text{ mV}$	L
Open	H

(1) H = high level, L = low level, ? = indeterminate

### SN65LVDM179 DRIVER

INPUT <sup>(1)</sup>	OUTPUTS <sup>(1)</sup>	
D	Y	Z
L	L	H
H	H	L
Open	L	H

(1) H = high level, L = low level

**SN65LVDM180, SN65LVDM050, and SN65LVDM051 RECEIVER**

INPUTS <sup>(1)</sup>		OUTPUT <sup>(1)</sup>
$V_{ID} = V_A - V_B$	$\overline{RE}$	R
$V_{ID} \geq 50 \text{ mV}$	L	H
$50 \text{ mV} < V_{ID} < 50 \text{ mV}$	L	?
$V_{ID} \leq -50 \text{ mV}$	L	L
Open	L	H
X	H	Z

(1) H = high level, L = low level, Z = high impedance, X = don't care

**SN65LVDM180, SN65LVDM050, and SN65LVDM051 DRIVER**

INPUTS <sup>(1)</sup>		OUTPUTS <sup>(1)</sup>	
D	DE	Y	Z
L	H	L	H
H	H	H	L
Open	H	L	H
X	L	Z	Z

(1) H = high level, L = low level, Z = high impedance, X = don't care

**EQUIVALENT INPUT AND OUTPUT SCHEMATIC DIAGRAMS**

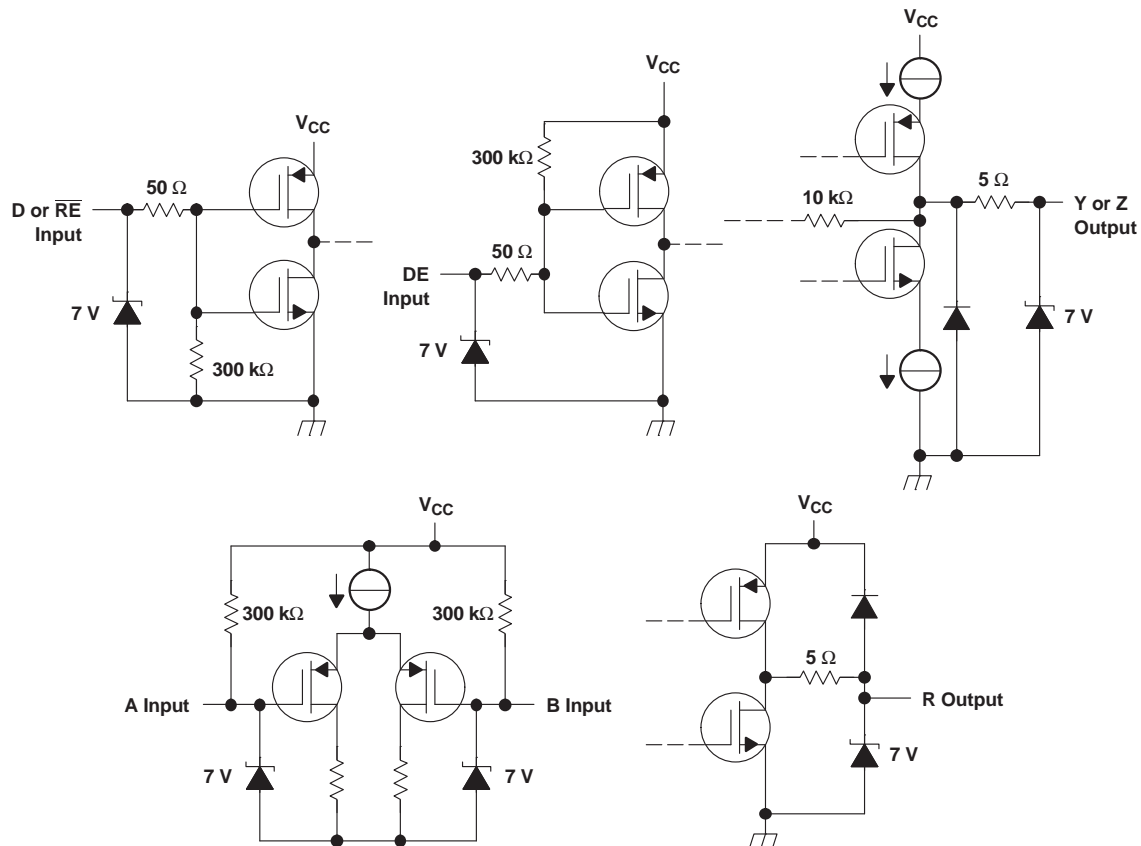

## ABSOLUTE MAXIMUM RATINGS

over operating free-air temperature range (unless otherwise noted)<sup>(1)</sup>

		UNIT
V <sub>CC</sub>	Supply voltage range <sup>(2)</sup>	–0.5 V to 4 V
Voltage range	D, R, DE, $\overline{RE}$	–0.5 V to 6 V
	Y, Z, A, and B	–0.5 V to 4 V
Electrostatic discharge	Y, Z, A, B, and GND <sup>(3)</sup>	Class 3, A:12 kV, B:600 V
	All	Class 3, A:7 kV, B:500 V
Continuous power dissipation		See Dissipation Rating Table
Storage temperature range		–65°C to 150°C

- (1) Stresses beyond those listed under *absolute maximum ratings* may cause permanent damage to the device. These are stress ratings only, and functional operation of the device at these or any other conditions beyond those indicated under *recommended operating conditions* is not implied. Exposure to absolute-maximum-rated conditions for extended periods may affect device reliability.
- (2) All voltage values, except differential I/O bus voltages, are with respect to network ground terminal.
- (3) Tested in accordance with MIL-STD-883C Method 3015.7.

## DISSIPATION RATING TABLE

PACKAGE	T <sub>A</sub> ≤ 25°C POWER RATING	DERATING FACTOR ABOVE T <sub>A</sub> = 25°C <sup>(1)</sup>	T <sub>A</sub> = 85°C POWER RATING
D(8)	635 mW	5.1 mW/°C	330 mW
D(14)	987 mW	7.9 mW/°C	513 mW
D(16)	1110 mW	8.9 mW/°C	577 mW
DGK	424 mW	3.4 mW/°C	220 mW
PW (14)	736 mW	5.9 mW/°C	383 mW
PW (16)	839 mW	6.7 mW/°C	437 mW

- (1) This is the inverse of the junction-to-ambient thermal resistance when board-mounted and with no air flow.

## RECOMMENDED OPERATING CONDITIONS

		MIN	NOM	MAX	UNIT
V <sub>CC</sub>	Supply voltage	3	3.3	3.6	V
V <sub>O</sub>	Driver output voltage	0		2.4	V
V <sub>IH</sub>	High-level input voltage	2			V
V <sub>IL</sub>	Low-level input voltage			0.8	V
V <sub>ID</sub>	Magnitude of differential input voltage	0.1		0.6	V
V <sub>IC</sub>	Common-mode input voltage (see Figure 6)	$\frac{ V_{ID} }{2}$	2.4	$-\frac{ V_{ID} }{2}$	V
		V <sub>CC</sub> -0.8			
T <sub>A</sub>	Operating free-air temperature	–40		85	°C

## DEVICE ELECTRICAL CHARACTERISTICS

over recommended operating conditions (unless otherwise noted)

PARAMETER		TEST CONDITIONS	MIN	TYP <sup>(1)</sup>	MAX	UNIT	
I <sub>CC</sub>	Supply current	SN65LVDM179	No receiver load, driver R <sub>L</sub> = 50 Ω		10	15	mA
		SN65LVDM180	Driver and receiver enabled, no receiver load, driver R <sub>L</sub> = 50 Ω		10	15	mA
			Driver enabled, receiver disabled, R <sub>L</sub> = 50 Ω		9	13	
			Driver disabled, receiver enabled, no load		1.7	5	
			Disabled		0.5	2	
		SN65LVDM050	Drivers and receivers enabled, no receiver loads, driver R <sub>L</sub> = 50 Ω		19	27	mA
			Drivers enabled, receivers disabled, R <sub>L</sub> = 50 Ω		16	24	
			Drivers disabled, receivers enabled, no loads		4	6	
			Disabled		0.5	1	
		SN65LVDM051	Drivers enabled, no receiver loads, driver R <sub>L</sub> = 50 Ω		19	27	mA
Drivers disabled, no loads			4	6			

(1) All typical values are at 25°C and with a 3.3 V supply.

## DRIVER ELECTRICAL CHARACTERISTICS

over recommended operating conditions (unless otherwise noted)

PARAMETER		TEST CONDITIONS	MIN	TYP	MAX	UNIT
V <sub>OD</sub>	Differential output voltage magnitude	R <sub>L</sub> = 50 Ω, See <a href="#">Figure 1</a> and <a href="#">Figure 2</a>	247	340	454	mV
Δ V <sub>OD</sub>	Change in differential output voltage magnitude between logic states		–50 <sup>(1)</sup>		50	
V <sub>OC(SS)</sub>	Steady-state common-mode output voltage	See <a href="#">Figure 3</a>	1.125	1.2	1.375	V
ΔV <sub>OC(SS)</sub>	Change in steady-state common-mode output voltage between logic states		–50		50	mV
V <sub>OC(PP)</sub>	Peak-to-peak common-mode output voltage		50		150	mV
I <sub>IH</sub>	High-level input current	DE	V <sub>IH</sub> = 5 V	–20	–0.5	μA
		D		2	20	
I <sub>IL</sub>	Low-level input current	DE	V <sub>IL</sub> = 0.8 V	–10	–0.5	μA
		D		2	10	
I <sub>OS</sub>	Short-circuit output current	V <sub>OY</sub> or V <sub>OZ</sub> = 0 V		7	10	mA
		V <sub>OD</sub> = 0 V		7	10	
I <sub>OZ</sub>	High-impedance output current	V <sub>O</sub> = 0 V or 2.4 V, other output at 1.2 V, DE AT 0.8 V	–47		47	μA
I <sub>O(OFF)</sub>	Power-off output current	V <sub>CC</sub> = 0 V, V <sub>O</sub> = 0 V or 2.4 V, other output at 1.2 V, DE AT 0.8 V	–47		47	μA
C <sub>IN</sub>	Input capacitance			3		pF

(1) The algebraic convention in which the least positive (most negative) value is designated minimum is used in this datasheet.

## RECEIVER ELECTRICAL CHARACTERISTICS

over recommended operating conditions (unless otherwise noted)

PARAMETER		TEST CONDITIONS	MIN	TYP <sup>(1)</sup>	MAX	UNIT
V <sub>IT+</sub>	Positive-going differential input voltage threshold	See Figure 5 and Table 2			50	mV
V <sub>IT-</sub>	Negative-going differential input voltage threshold		-50			
V <sub>OH</sub>	High-level output voltage	I <sub>OH</sub> = -8 mA	2.4			V
V <sub>OL</sub>	Low-level output voltage	I <sub>OL</sub> = 8 mA			0.4	V
I <sub>I</sub>	Input current (A or B inputs)	V <sub>I</sub> = 0	-20	-11		μA
		V <sub>I</sub> = 2.4 V		-3	-1.2	
I <sub>I(OFF)</sub>	Power-off input current (A or B inputs)	V <sub>CC</sub> = 0	-20		20	μA
I <sub>IH</sub>	High-level input current (enables)	V <sub>IH</sub> = 5 V			10	μA
I <sub>IL</sub>	Low-level input current (enables)	V <sub>IL</sub> = 0.8 V			10	μA
I <sub>OZ</sub>	High-impedance output current	V <sub>O</sub> = 0 or 5 V	-10		10	μA
C <sub>I</sub>	Input capacitance			5		pF

(1) All typical values are at 25°C and with a 3.3-V supply.

## DRIVER SWITCHING CHARACTERISTICS

over recommended operating conditions (unless otherwise noted)

PARAMETER		TEST CONDITIONS	MIN	TYP <sup>(1)</sup>	MAX	UNIT
t <sub>PLH</sub>	Propagation delay time, low-to-high-level output	R <sub>L</sub> = 50Ω, C <sub>L</sub> = 10 pF, See Figure 6		1.7	2.7	ns
t <sub>PHL</sub>	Propagation delay time, high-to-low-level output			1.7	2.7	ns
t <sub>r</sub>	Differential output signal rise time			0.6	1	ns
t <sub>f</sub>	Differential output signal fall time			0.6	1	ns
t <sub>sk(p)</sub>	Pulse skew ( t <sub>pHL</sub> - t <sub>pLH</sub>  )			250		ps
t <sub>sk(o)</sub>	Channel-to-channel output skew <sup>(2)</sup>			100		ps
t <sub>sk(pp)</sub>	Part-to-part skew <sup>(3)</sup>				1	ns
t <sub>PZH</sub>	Propagation delay time, high-impedance-to-high-level output	See Figure 7		6	10	ns
t <sub>PZL</sub>	Propagation delay time, high-impedance-to-low-level output			6	10	ns
t <sub>PHZ</sub>	Propagation delay time, high-level-to-high-impedance output			4	10	ns
t <sub>PLZ</sub>	Propagation delay time, low-level-to-high-impedance output			5	10	ns

(1) All typical values are at 25°C and with a 3.3-V supply.

(2) t<sub>sk(o)</sub> is the maximum delay time difference between drivers on the same device.

(3) t<sub>sk(pp)</sub> is the magnitude of the difference in propagation delay times between any specified terminals of two devices when both devices operate with the same supply voltages, at the same temperature, and have identical packages and test circuits.

## RECEIVER SWITCHING CHARACTERISTICS

over recommended operating conditions (unless otherwise noted)

PARAMETER		TEST CONDITIONS	MIN	TYP <sup>(1)</sup>	MAX	UNIT
$t_{PLH}$	Propagation delay time, low-to-high-level output	$C_L = 10$ pF, See Figure 6		3.7	4.5	ns
$t_{PHL}$	Propagation delay time, high-to-low-level output			3.7	4.5	ns
$t_{sk(p)}$	Pulse skew ( $ t_{PHL} - t_{PLH} $ )			0.1		ns
$t_{sk(o)}$	Channel-to-channel output skew			0.2		ns
$t_{sk(pp)}$	Part-to-part skew <sup>(2)</sup>				1	ns
$t_r$	Output signal rise time	$C_L = 10$ pF, See Figure 6		0.7	1.5	ns
$t_f$	Output signal fall time			0.9	1.5	ns
$t_{PZH}$	Propagation delay time, high-level-to-high-impedance output	See Figure 7		2.5		ns
$t_{PZL}$	Propagation delay time, low-level-to-low-impedance output			2.5		ns
$t_{PHZ}$	Propagation delay time, high-impedance-to-high-level output			7		ns
$t_{PLZ}$	Propagation delay time, low-impedance-to-high-level output			4		ns

- (1) All typical values are at 25°C and with a 3.3-V supply.  
 (2)  $t_{sk(pp)}$  is the magnitude of the difference in propagation delay times between any specified terminals of two devices when both devices operate with the same supply voltages, at the same temperature, and have identical packages and test circuits.

## PARAMETER MEASUREMENT INFORMATION

### DRIVER

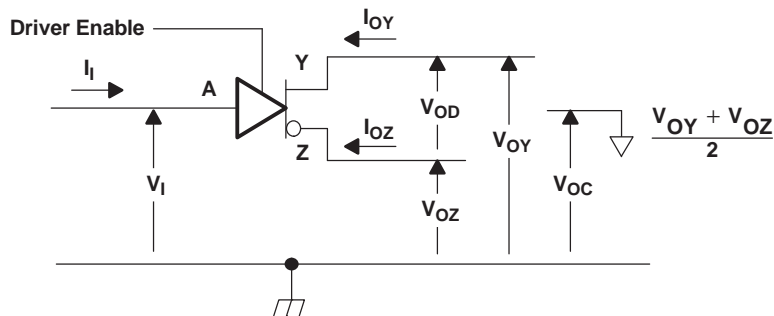
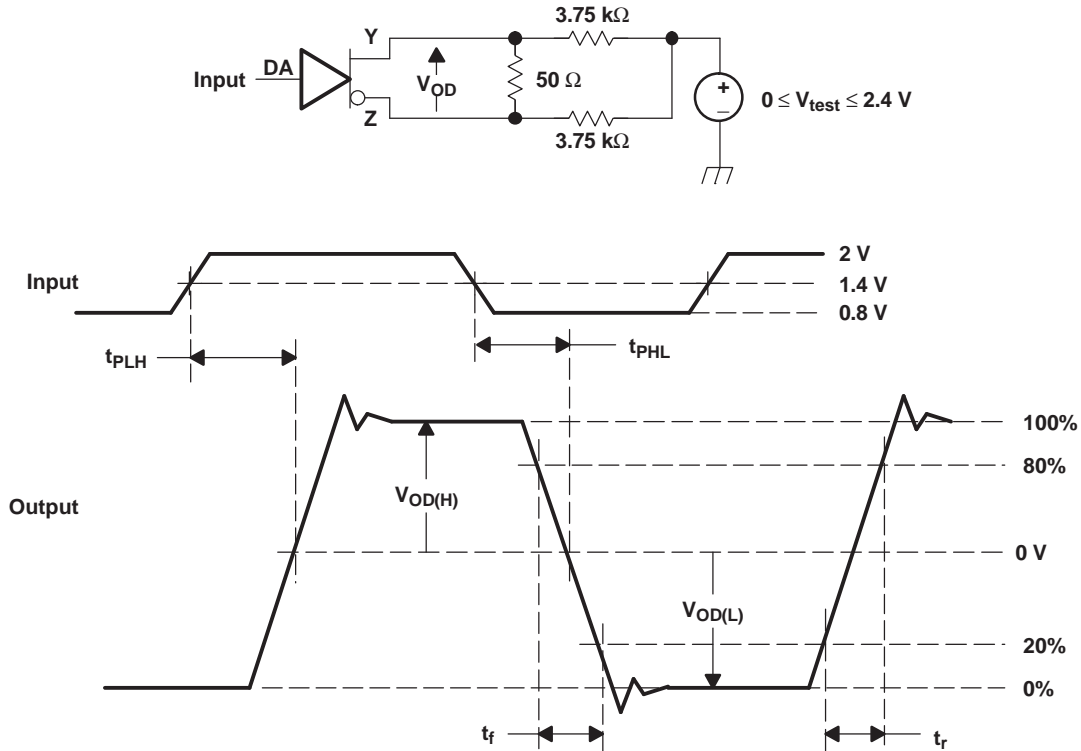

Figure 1. Driver Voltage and Current Definitions

PARAMETER MEASUREMENT INFORMATION (continued)



- A. All input pulses are supplied by a generator having the following characteristics:  $t_r$  or  $t_f \leq 1$  ns, pulse repetition rate (PRR) = 50 Mpps, pulse width =  $10 \pm 0.2$  ns.  $C_L$  includes instrumentation and fixture capacitance within 0,06 mm of the D.U.T.

Figure 2. Test Circuit, Timing, and Voltage Definitions for the Differential Output Signal

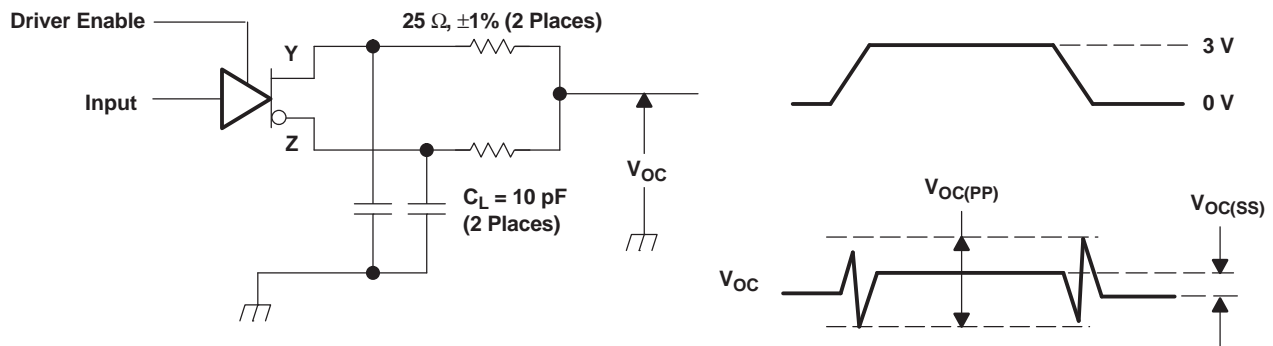

- A. All input pulses are supplied by a generator having the following characteristics:  $t_r$  or  $t_f \leq 1$  ns, pulse repetition rate (PRR) = 50 Mpps, pulse width =  $10 \pm 0.2$  ns.  $C_L$  includes instrumentation and fixture capacitance within 0,06 mm of the D.U.T. The measurement of  $V_{OC(PP)}$  is made on test equipment with a -3 dB bandwidth of at least 300 MHz.

Figure 3. Test Circuit and Definitions for the Driver Common-Mode Output Voltage

PARAMETER MEASUREMENT INFORMATION (continued)

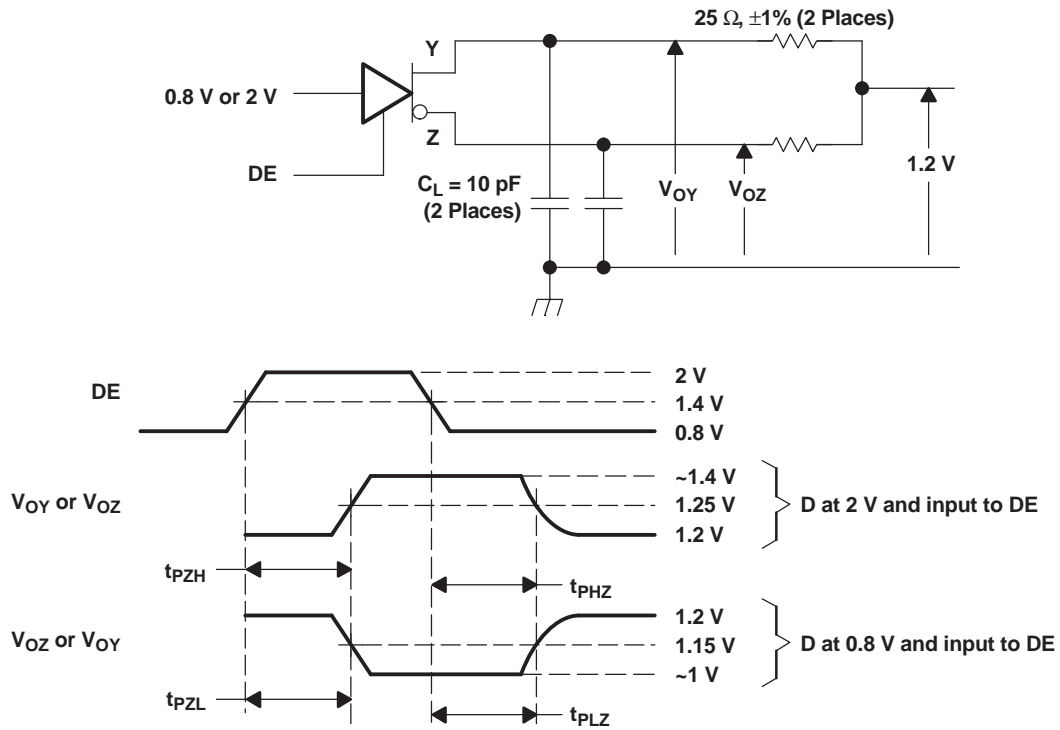

- A. All input pulses are supplied by a generator having the following characteristics:  $t_r$  or  $t_f \leq 1 \text{ ns}$ , pulse repetition rate (PRR) = 0.5 Mpps, pulse width =  $500 \pm 10 \text{ ns}$ .  $C_L$  includes instrumentation and fixture capacitance within 0,06 mm of the D.U.T.

Figure 4. Enable and Disable Time Circuit and Definitions

PARAMETER MEASUREMENT INFORMATION (continued)

RECEIVER

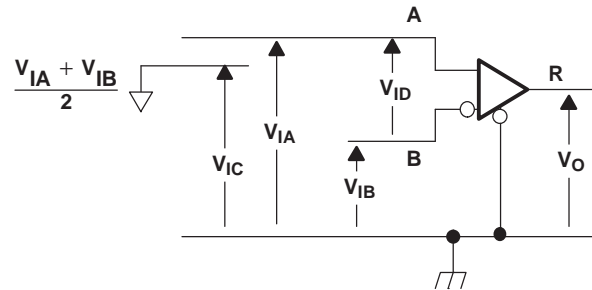
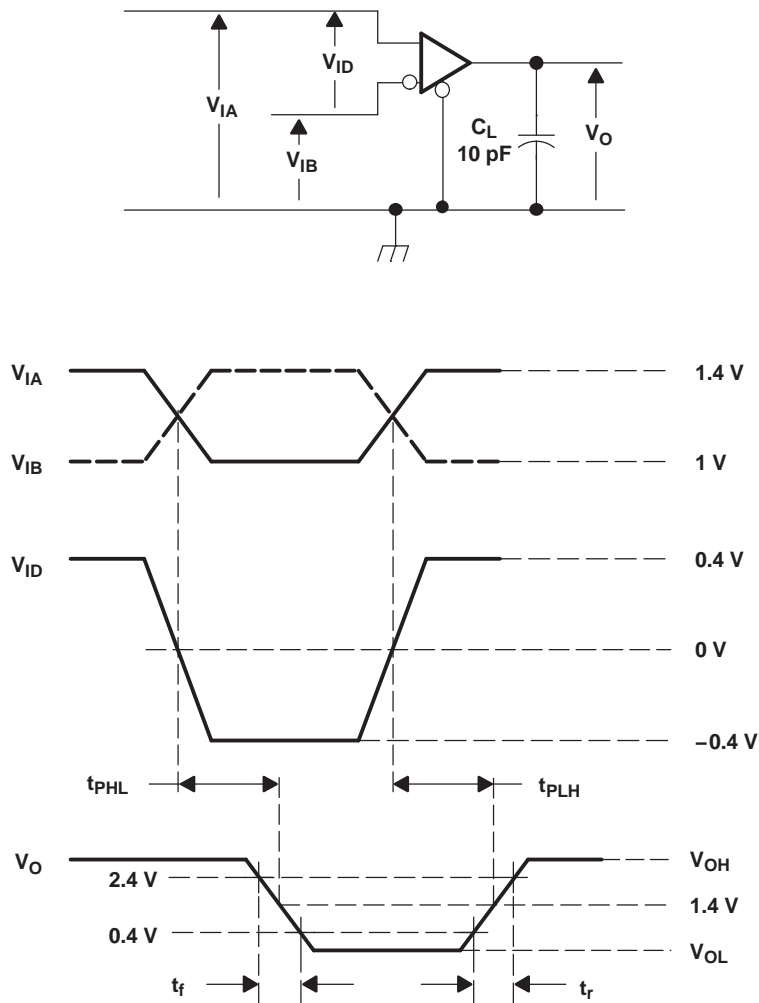

Figure 5. Receiver Voltage Definitions

Table 2. Receiver Minimum and Maximum Input Threshold Test Voltages

APPLIED VOLTAGES (V)		RESULTING DIFFERENTIAL INPUT VOLTAGE (mV)	RESULTING COMMON-MODE INPUT VOLTAGE (V)
$V_{IA}$	$V_{IB}$	$V_{ID}$	$V_{IC}$
1.225	1.175	50	1.2
1.175	1.225	-50	1.2
2.375	2.325	50	2.35
2.325	2.375	-50	2.35
0.05	0	50	0.05
0	0.05	-50	0.05
1.5	0.9	600	1.2
0.9	1.5	-600	1.2
2.4	1.8	600	2.1
1.8	2.4	-600	2.1
0.6	0	600	0.3
0	0.6	-600	0.3



- A. All input pulses are supplied by a generator having the following characteristics:  $t_r$  or  $t_f \leq 1$  ns, pulse repetition rate (PRR) = 50 Mpps, pulse width =  $10 \pm 0.2$  ns.  $C_L$  includes instrumentation and fixture capacitance within 0,06 mm of the D.U.T.

**Figure 6. Timing Test Circuit and Waveforms**

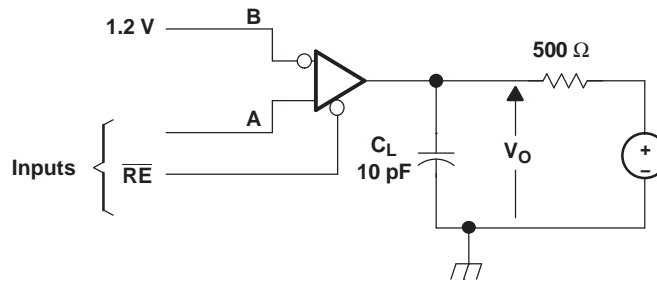

NOTE A: All input pulses are supplied by a generator having the following characteristics:  $t_r$  or  $t_f \leq 1$  ns, pulse repetition rate (PRR) = 0.5 Mpps, pulse width =  $500 \pm 10$  ns.  $C_L$  includes instrumentation and fixture capacitance within 0,06 mm of the D.U.T.

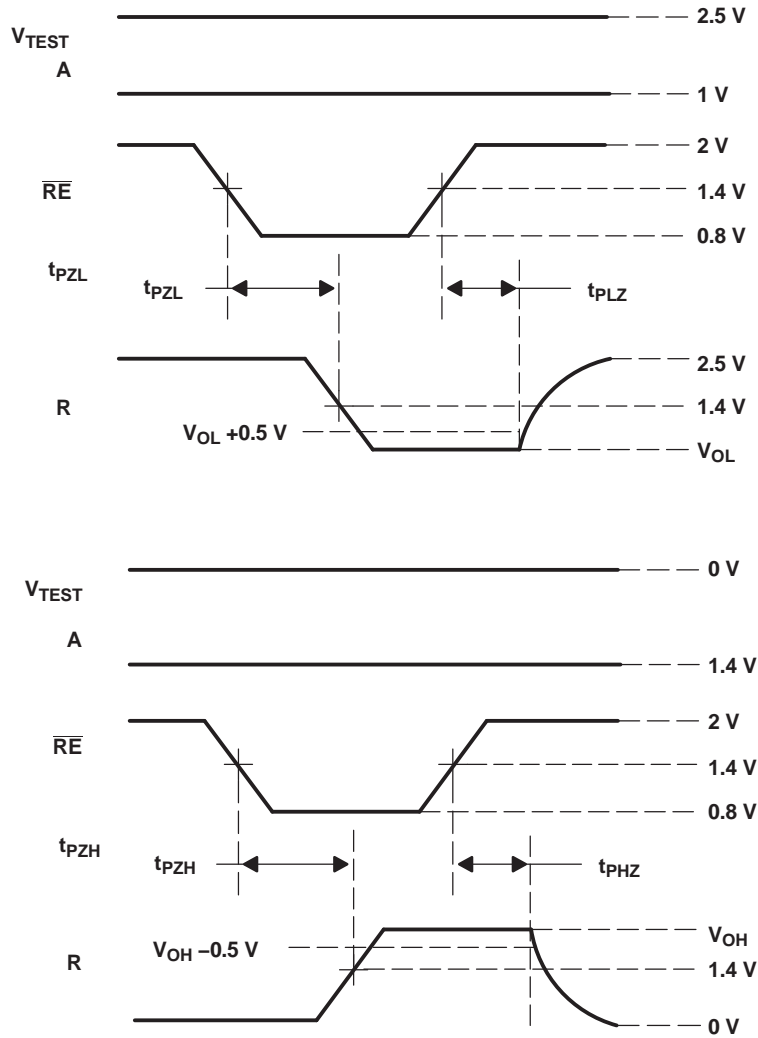
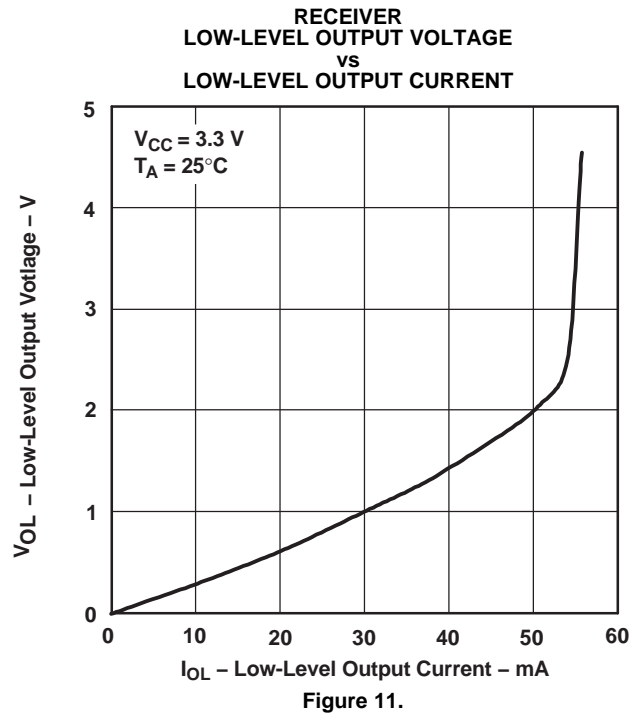
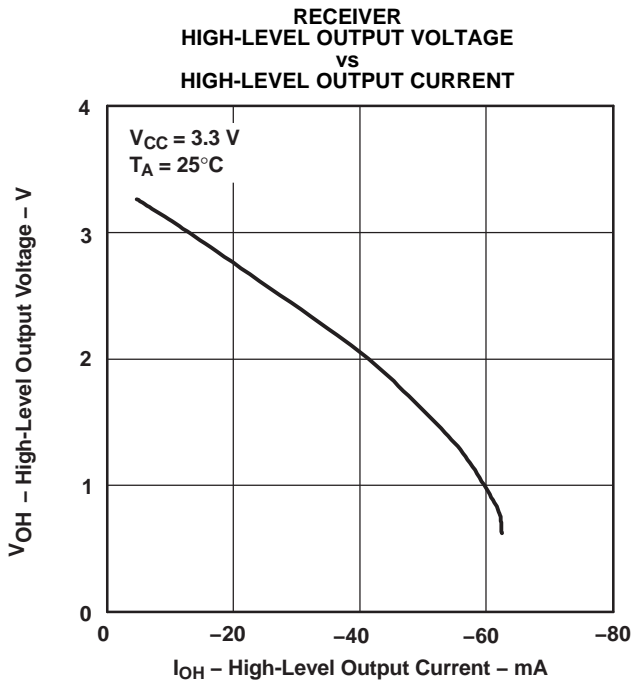
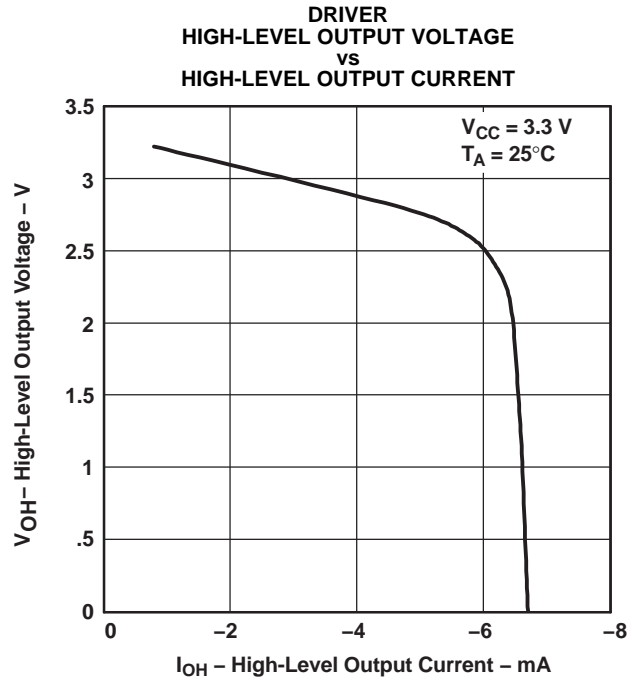
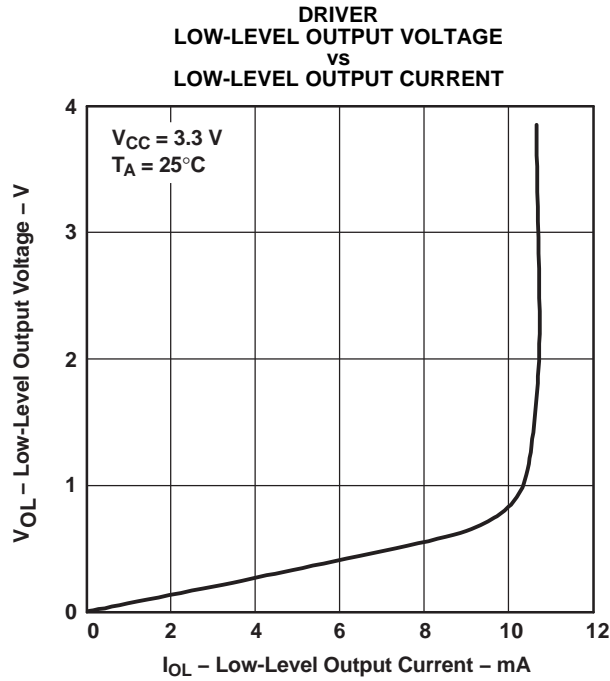

Figure 7. Enable/Disable Time Test Circuit and Waveforms

TYPICAL CHARACTERISTICS



TYPICAL CHARACTERISTICS (continued)

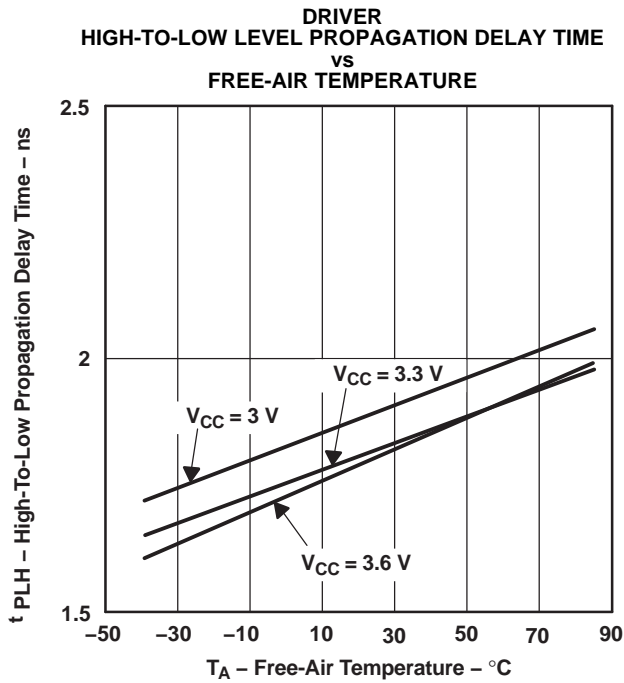

Figure 12.

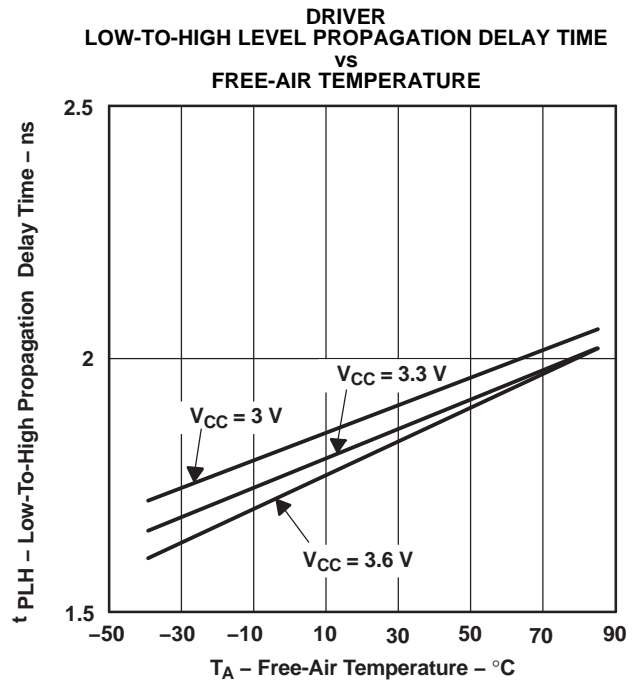

Figure 13.

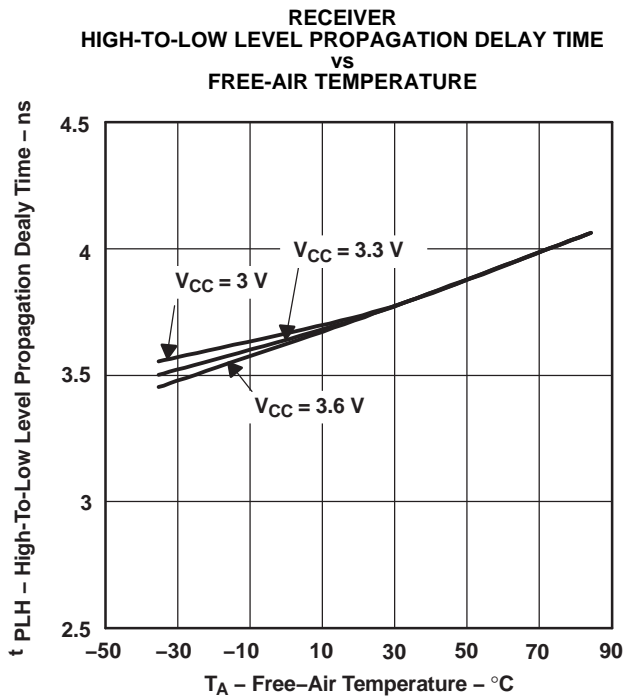

Figure 14.

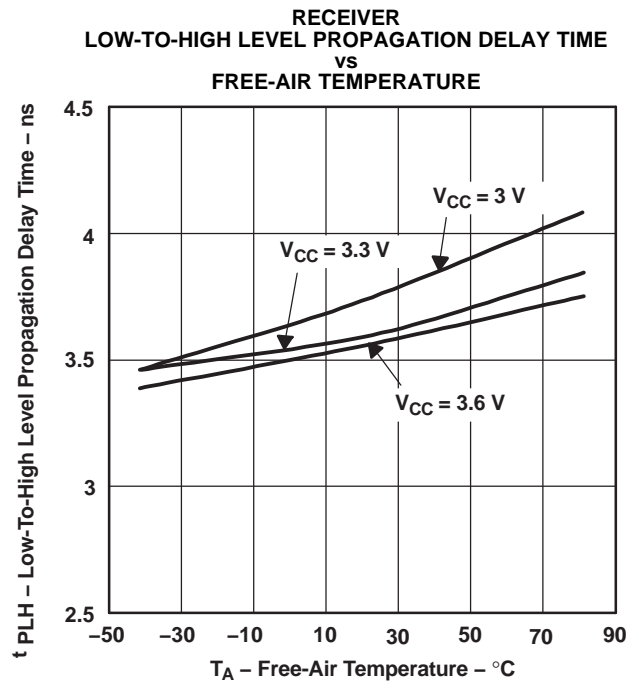

Figure 15.

## APPLICATION INFORMATION

### Equipment

- Hewlett Packard HP6624A DC power supply
- Tektronix TDS7404 Real Time Scope
- Agilent ParBERT E4832A

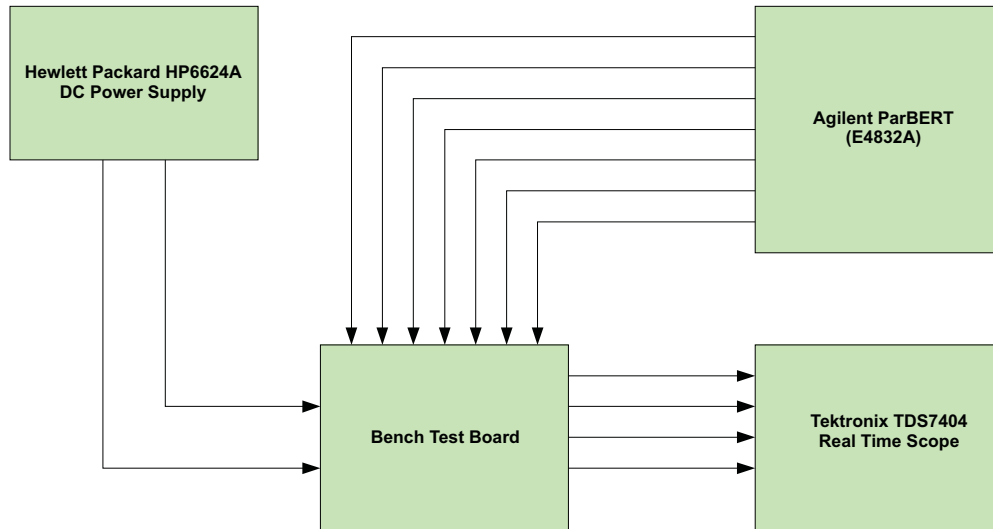
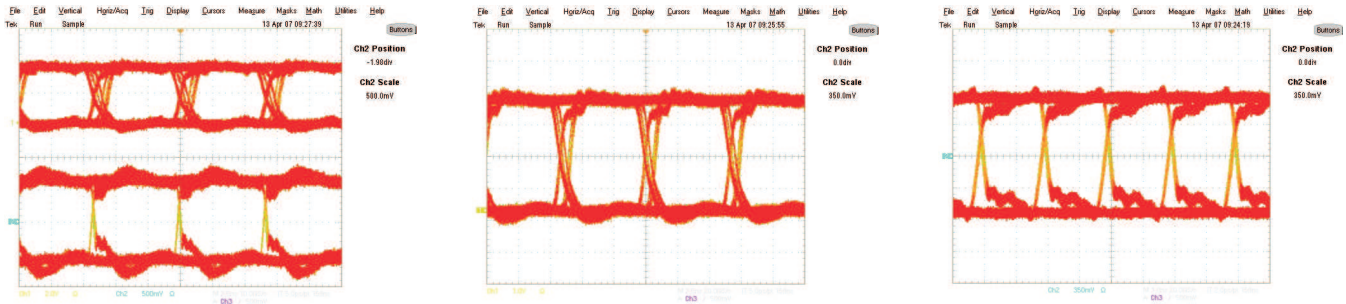

Figure 16. Equipment Setup



(a)

(b)

(c)

- Tx + Rx running at 150 Mbps; Channel 1: R, Channel 2: Y-Z
- Rx only running at 150 Mbps; Channel 1: R
- Tx only running at 500 Mbps; Channel 1: Y-Z

Figure 17. Typical Eye Patterns SN65LVDM179: (T = 25°C; V<sub>CC</sub> = 3.6 V; PRBS = 2<sup>23</sup>-1)

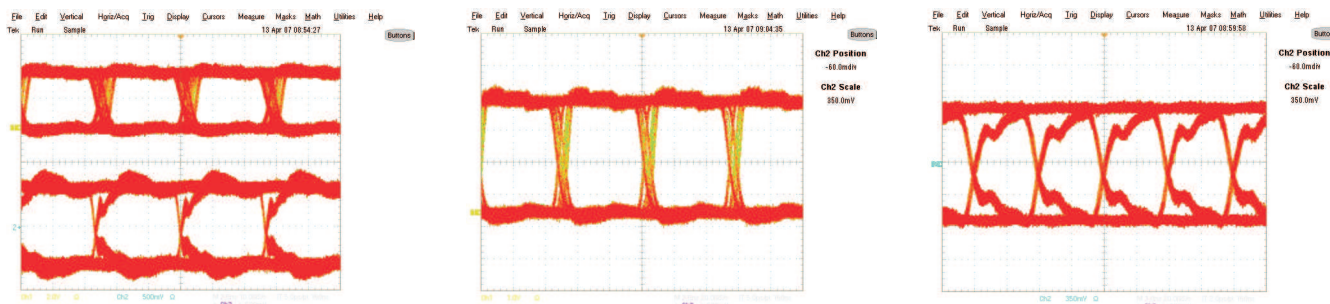

- (a) Tx + Rx running at 150 Mbps; Channel 1: R, Channel 2: Y-Z  
 (b) Rx only running at 150 Mbps; Channel 1: R  
 (c) Tx only running at 500 Mbps; Channel 1: Y-Z

Figure 18. Typical Eye Patterns SN65LVDM180: ( $T = 25^{\circ}\text{C}$ ;  $V_{CC} = 3.6\text{ V}$ ; PRBS =  $2^{23}-1$ )

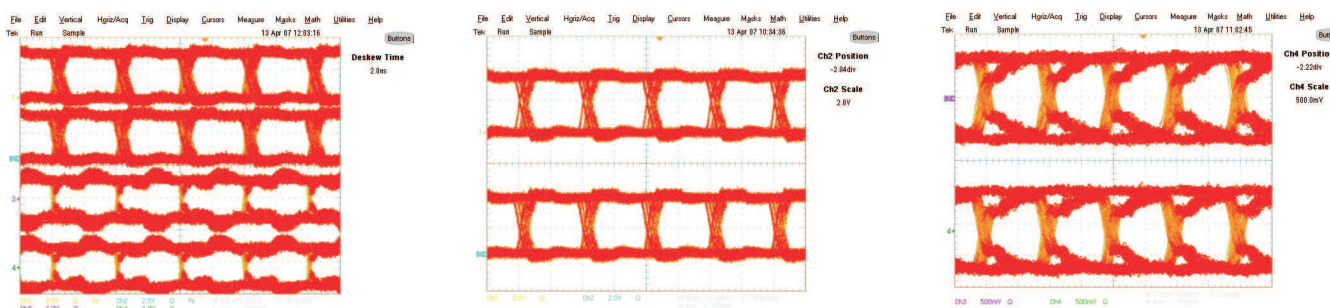

- (a) All buffers running at 100 Mbps; Channel 1: R, Channel 2: 2R, Channel 3: 1Y-1Z, Channel 4: 2Y-2Z,  
 (b) Rx buffers only running at 100 Mbps; Channel 1: R, Channel 2: 2R  
 (c) Tx buffers only running at 400 Mbps; Channel 3: 1Y-1Z, Channel 4: 2Y-2Z,

Figure 19. Typical Eye Patterns SN65LVDM050: ( $T = 25^{\circ}\text{C}$ ;  $V_{CC} = 3.6\text{ V}$ ; PRBS =  $2^{23}-1$ )

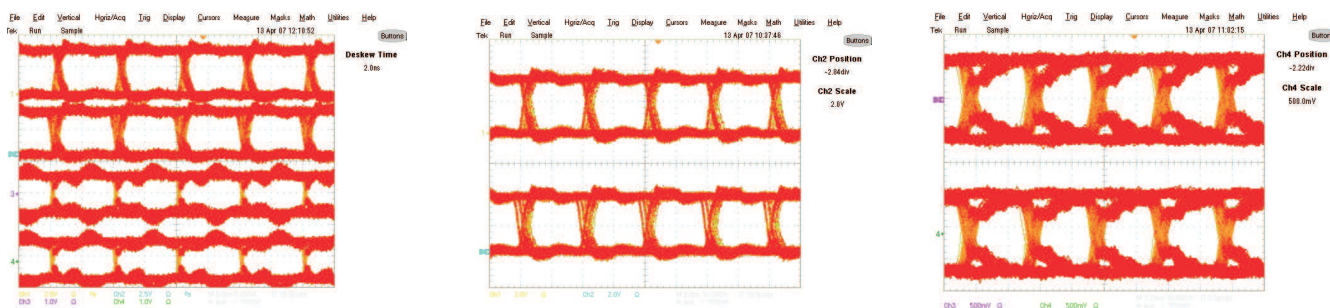

- (a) All buffers running at 100 Mbps; Channel 1: R, Channel 2: 2R, Channel 3: 1Y-1Z, Channel 4: 2Y-2Z,  
 (b) Rx buffers only running at 100 Mbps; Channel 1: R, Channel 2: 2R  
 (c) Tx buffers only running at 400 Mbps; Channel 3: 1Y-1Z, Channel 4: 2Y-2Z,

Figure 20. Typical Eye Patterns SN65LVDM051: ( $T = 25^{\circ}\text{C}$ ;  $V_{CC} = 3.6\text{ V}$ ; PRBS =  $2^{23}-1$ )

The devices are generally used as building blocks for high-speed point-to-point data transmission. Ground differences are less than 1 V with a low common-mode output and balanced interface for low noise emissions. Devices can interoperate with RS-422, PECL, and IEEE-P1596. Drivers/receivers maintain ECL speeds without the power and dual supply requirements.

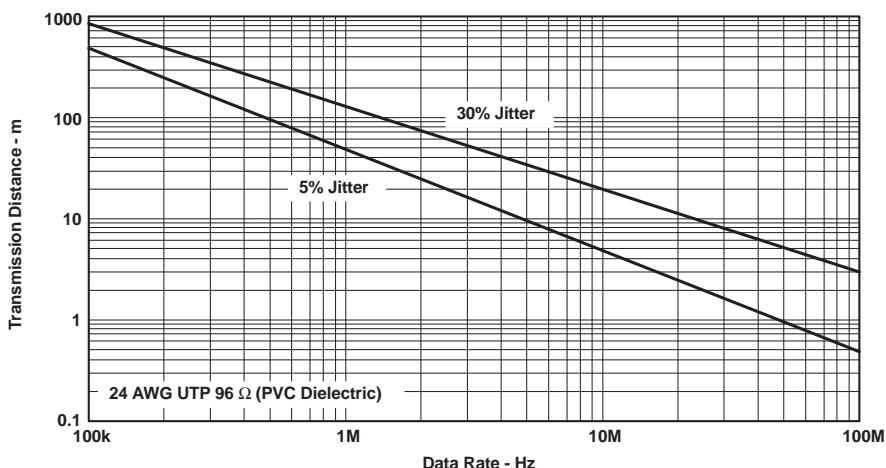

Figure 21. Data Transmission Distance Versus Rate

### FAIL SAFE

One of the most common problems with differential signaling applications is how the system responds when no differential voltage is present on the signal pair. The LVDS receiver is like most differential line receivers, in that its output logic state can be indeterminate when the differential input voltage is between  $-50$  mV and  $50$  mV and within its recommended input common-mode voltage range. TI's LVDS receiver is different; however, in the way it handles the open-input circuit situation.

Open-circuit means that there is little or no input current to the receiver from the data line itself. This could be when the driver is in a high-impedance state or the cable is disconnected. When this occurs, the LVDS receiver pulls each line of the signal pair to near  $V_{CC}$  through  $300$ -k $\Omega$  resistors as shown in Figure 22. The fail-safe feature uses an AND gate with input voltage thresholds at about  $2.3$  V to  $V_{CC} - 0.4$  V to detect this condition and force the output to a high-level, regardless of the differential input voltage.

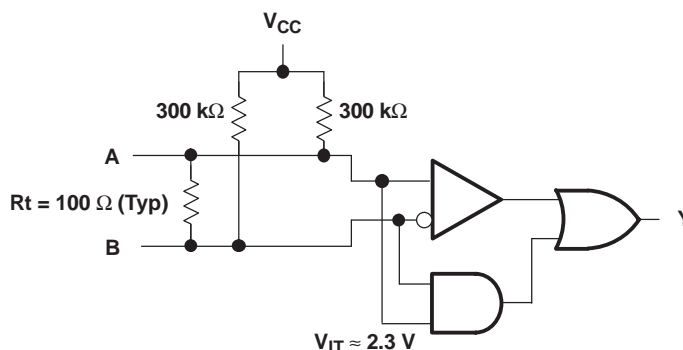

Figure 22. Open-Circuit Fail Safe of the LVDS Receiver

It is only under these conditions that the output of the receiver is valid with less than a  $50$ -mV differential input voltage magnitude. The presence of the termination resistor,  $R_t$ , does not affect the fail-safe function as long as it is connected as shown in the figure. Other termination circuits may allow a dc current to ground that could defeat the pullup currents from the receiver and the fail-safe feature.

## REVISION HISTORY

Changes from Revision I (January 2009) to Revision J	Page
• Changed value from 40 to -40 .....	4
• Deleted value 85 from NOM value and moved to max.....	4

**PACKAGING INFORMATION**

Orderable Device	Status (1)	Package Type	Package Drawing	Pins	Package Qty	Eco Plan (2)	Lead/Ball Finish (6)	MSL Peak Temp (3)	Op Temp (°C)	Device Marking (4/5)	Samples
SN65LVDM050D	ACTIVE	SOIC	D	16	40	Green (RoHS & no Sb/Br)	CU NIPDAU	Level-1-260C-UNLIM	-40 to 85	LVDM050	<a href="#">Samples</a>
SN65LVDM050DG4	ACTIVE	SOIC	D	16	40	Green (RoHS & no Sb/Br)	CU NIPDAU	Level-1-260C-UNLIM	-40 to 85	LVDM050	<a href="#">Samples</a>
SN65LVDM050DR	ACTIVE	SOIC	D	16	2500	Green (RoHS & no Sb/Br)	CU NIPDAU	Level-1-260C-UNLIM	-40 to 85	LVDM050	<a href="#">Samples</a>
SN65LVDM050PW	ACTIVE	TSSOP	PW	16	90	Green (RoHS & no Sb/Br)	CU NIPDAU	Level-1-260C-UNLIM	-40 to 85	LVDM050	<a href="#">Samples</a>
SN65LVDM050PWG4	ACTIVE	TSSOP	PW	16	90	Green (RoHS & no Sb/Br)	CU NIPDAU	Level-1-260C-UNLIM	-40 to 85	LVDM050	<a href="#">Samples</a>
SN65LVDM050PWR	ACTIVE	TSSOP	PW	16	2000	Green (RoHS & no Sb/Br)	CU NIPDAU	Level-1-260C-UNLIM	-40 to 85	LVDM050	<a href="#">Samples</a>
SN65LVDM050PWRG4	ACTIVE	TSSOP	PW	16	2000	Green (RoHS & no Sb/Br)	CU NIPDAU	Level-1-260C-UNLIM	-40 to 85	LVDM050	<a href="#">Samples</a>
SN65LVDM051D	ACTIVE	SOIC	D	16	40	Green (RoHS & no Sb/Br)	CU NIPDAU	Level-1-260C-UNLIM	-40 to 85	LVDM051	<a href="#">Samples</a>
SN65LVDM051DG4	ACTIVE	SOIC	D	16	40	Green (RoHS & no Sb/Br)	CU NIPDAU	Level-1-260C-UNLIM	-40 to 85	LVDM051	<a href="#">Samples</a>
SN65LVDM051DR	ACTIVE	SOIC	D	16	2500	Green (RoHS & no Sb/Br)	CU NIPDAU	Level-1-260C-UNLIM	-40 to 85	LVDM051	<a href="#">Samples</a>
SN65LVDM051DRG4	ACTIVE	SOIC	D	16	2500	Green (RoHS & no Sb/Br)	CU NIPDAU	Level-1-260C-UNLIM	-40 to 85	LVDM051	<a href="#">Samples</a>
SN65LVDM051PW	ACTIVE	TSSOP	PW	16	90	Green (RoHS & no Sb/Br)	CU NIPDAU	Level-1-260C-UNLIM	-40 to 85	LVDM051	<a href="#">Samples</a>
SN65LVDM051PWG4	ACTIVE	TSSOP	PW	16	90	Green (RoHS & no Sb/Br)	CU NIPDAU	Level-1-260C-UNLIM	-40 to 85	LVDM051	<a href="#">Samples</a>
SN65LVDM051PWR	ACTIVE	TSSOP	PW	16	2000	Green (RoHS & no Sb/Br)	CU NIPDAU	Level-1-260C-UNLIM	-40 to 85	LVDM051	<a href="#">Samples</a>
SN65LVDM051PWRG4	ACTIVE	TSSOP	PW	16	2000	Green (RoHS & no Sb/Br)	CU NIPDAU	Level-1-260C-UNLIM	-40 to 85	LVDM051	<a href="#">Samples</a>
SN65LVDM179D	ACTIVE	SOIC	D	8	75	Green (RoHS & no Sb/Br)	CU NIPDAU	Level-1-260C-UNLIM	-40 to 85	DM179	<a href="#">Samples</a>
SN65LVDM179DG4	ACTIVE	SOIC	D	8	75	Green (RoHS & no Sb/Br)	CU NIPDAU	Level-1-260C-UNLIM	-40 to 85	DM179	<a href="#">Samples</a>

Orderable Device	Status (1)	Package Type	Package Drawing	Pins	Package Qty	Eco Plan (2)	Lead/Ball Finish (6)	MSL Peak Temp (3)	Op Temp (°C)	Device Marking (4/5)	Samples
SN65LVDM179DGK	ACTIVE	VSSOP	DGK	8	80	Green (RoHS & no Sb/Br)	CU NIPDAU	Level-1-260C-UNLIM	-40 to 85	M79	<a href="#">Samples</a>
SN65LVDM179DGKG4	ACTIVE	VSSOP	DGK	8	80	Green (RoHS & no Sb/Br)	CU NIPDAU	Level-1-260C-UNLIM	-40 to 85	M79	<a href="#">Samples</a>
SN65LVDM179DGKR	ACTIVE	VSSOP	DGK	8	2500	Green (RoHS & no Sb/Br)	CU NIPDAU	Level-1-260C-UNLIM	-40 to 85	M79	<a href="#">Samples</a>
SN65LVDM179DR	ACTIVE	SOIC	D	8	2500	Green (RoHS & no Sb/Br)	CU NIPDAU	Level-1-260C-UNLIM	-40 to 85	DM179	<a href="#">Samples</a>
SN65LVDM179DRG4	ACTIVE	SOIC	D	8	2500	Green (RoHS & no Sb/Br)	CU NIPDAU	Level-1-260C-UNLIM	-40 to 85	DM179	<a href="#">Samples</a>
SN65LVDM180D	ACTIVE	SOIC	D	14	50	Green (RoHS & no Sb/Br)	CU NIPDAU	Level-1-260C-UNLIM	-40 to 85	LVDM180	<a href="#">Samples</a>
SN65LVDM180DG4	ACTIVE	SOIC	D	14	50	Green (RoHS & no Sb/Br)	CU NIPDAU	Level-1-260C-UNLIM	-40 to 85	LVDM180	<a href="#">Samples</a>
SN65LVDM180DR	ACTIVE	SOIC	D	14	2500	Green (RoHS & no Sb/Br)	CU NIPDAU	Level-1-260C-UNLIM	-40 to 85	LVDM180	<a href="#">Samples</a>
SN65LVDM180DRG4	ACTIVE	SOIC	D	14	2500	Green (RoHS & no Sb/Br)	CU NIPDAU	Level-1-260C-UNLIM	-40 to 85	LVDM180	<a href="#">Samples</a>
SN65LVDM180PW	ACTIVE	TSSOP	PW	14	90	Green (RoHS & no Sb/Br)	CU NIPDAU	Level-1-260C-UNLIM	-40 to 85	LVDM180	<a href="#">Samples</a>
SN65LVDM180PWG4	ACTIVE	TSSOP	PW	14	90	Green (RoHS & no Sb/Br)	CU NIPDAU	Level-1-260C-UNLIM	-40 to 85	LVDM180	<a href="#">Samples</a>
SN65LVDM180PWR	ACTIVE	TSSOP	PW	14	2000	Green (RoHS & no Sb/Br)	CU NIPDAU	Level-1-260C-UNLIM	-40 to 85	LVDM180	<a href="#">Samples</a>

(1) The marketing status values are defined as follows:

**ACTIVE:** Product device recommended for new designs.

**LIFEBUY:** TI has announced that the device will be discontinued, and a lifetime-buy period is in effect.

**NRND:** Not recommended for new designs. Device is in production to support existing customers, but TI does not recommend using this part in a new design.

**PREVIEW:** Device has been announced but is not in production. Samples may or may not be available.

**OBSELETE:** TI has discontinued the production of the device.

(2) Eco Plan - The planned eco-friendly classification: Pb-Free (RoHS), Pb-Free (RoHS Exempt), or Green (RoHS & no Sb/Br) - please check <http://www.ti.com/productcontent> for the latest availability information and additional product content details.

**TBD:** The Pb-Free/Green conversion plan has not been defined.

**Pb-Free (RoHS):** TI's terms "Lead-Free" or "Pb-Free" mean semiconductor products that are compatible with the current RoHS requirements for all 6 substances, including the requirement that lead not exceed 0.1% by weight in homogeneous materials. Where designed to be soldered at high temperatures, TI Pb-Free products are suitable for use in specified lead-free processes.

---

**Pb-Free (RoHS Exempt):** This component has a RoHS exemption for either 1) lead-based flip-chip solder bumps used between the die and package, or 2) lead-based die adhesive used between the die and leadframe. The component is otherwise considered Pb-Free (RoHS compatible) as defined above.

**Green (RoHS & no Sb/Br):** TI defines "Green" to mean Pb-Free (RoHS compatible), and free of Bromine (Br) and Antimony (Sb) based flame retardants (Br or Sb do not exceed 0.1% by weight in homogeneous material)

<sup>(3)</sup> MSL, Peak Temp. - The Moisture Sensitivity Level rating according to the JEDEC industry standard classifications, and peak solder temperature.

<sup>(4)</sup> There may be additional marking, which relates to the logo, the lot trace code information, or the environmental category on the device.

<sup>(5)</sup> Multiple Device Markings will be inside parentheses. Only one Device Marking contained in parentheses and separated by a "~" will appear on a device. If a line is indented then it is a continuation of the previous line and the two combined represent the entire Device Marking for that device.

<sup>(6)</sup> Lead/Ball Finish - Orderable Devices may have multiple material finish options. Finish options are separated by a vertical ruled line. Lead/Ball Finish values may wrap to two lines if the finish value exceeds the maximum column width.

**Important Information and Disclaimer:** The information provided on this page represents TI's knowledge and belief as of the date that it is provided. TI bases its knowledge and belief on information provided by third parties, and makes no representation or warranty as to the accuracy of such information. Efforts are underway to better integrate information from third parties. TI has taken and continues to take reasonable steps to provide representative and accurate information but may not have conducted destructive testing or chemical analysis on incoming materials and chemicals. TI and TI suppliers consider certain information to be proprietary, and thus CAS numbers and other limited information may not be available for release.

In no event shall TI's liability arising out of such information exceed the total purchase price of the TI part(s) at issue in this document sold by TI to Customer on an annual basis.

**OTHER QUALIFIED VERSIONS OF SN65LVDM050, SN65LVDM051 :**

- Automotive: [SN65LVDM050-Q1](#), [SN65LVDM051-Q1](#)

NOTE: Qualified Version Definitions:

- Automotive - Q100 devices qualified for high-reliability automotive applications targeting zero defects

**TAPE AND REEL INFORMATION**

**QUADRANT ASSIGNMENTS FOR PIN 1 ORIENTATION IN TAPE**

\*All dimensions are nominal

Device	Package Type	Package Drawing	Pins	SPQ	Reel Diameter (mm)	Reel Width W1 (mm)	A0 (mm)	B0 (mm)	K0 (mm)	P1 (mm)	W (mm)	Pin1 Quadrant
SN65LVDM050DR	SOIC	D	16	2500	330.0	16.4	6.5	10.3	2.1	8.0	16.0	Q1
SN65LVDM050PWR	TSSOP	PW	16	2000	330.0	12.4	6.9	5.6	1.6	8.0	12.0	Q1
SN65LVDM051DR	SOIC	D	16	2500	330.0	16.4	6.5	10.3	2.1	8.0	16.0	Q1
SN65LVDM051PWR	TSSOP	PW	16	2000	330.0	12.4	6.9	5.6	1.6	8.0	12.0	Q1
SN65LVDM179DGKR	VSSOP	DGK	8	2500	330.0	12.4	5.3	3.4	1.4	8.0	12.0	Q1
SN65LVDM179DR	SOIC	D	8	2500	330.0	12.4	6.4	5.2	2.1	8.0	12.0	Q1
SN65LVDM180DR	SOIC	D	14	2500	330.0	16.4	6.5	9.0	2.1	8.0	16.0	Q1
SN65LVDM180PWR	TSSOP	PW	14	2000	330.0	12.4	6.9	5.6	1.6	8.0	12.0	Q1

**TAPE AND REEL BOX DIMENSIONS**

\*All dimensions are nominal

Device	Package Type	Package Drawing	Pins	SPQ	Length (mm)	Width (mm)	Height (mm)
SN65LVDM050DR	SOIC	D	16	2500	367.0	367.0	38.0
SN65LVDM050PWR	TSSOP	PW	16	2000	367.0	367.0	35.0
SN65LVDM051DR	SOIC	D	16	2500	367.0	367.0	38.0
SN65LVDM051PWR	TSSOP	PW	16	2000	367.0	367.0	35.0
SN65LVDM179DGKR	VSSOP	DGK	8	2500	358.0	335.0	35.0
SN65LVDM179DR	SOIC	D	8	2500	340.5	338.1	20.6
SN65LVDM180DR	SOIC	D	14	2500	367.0	367.0	38.0
SN65LVDM180PWR	TSSOP	PW	14	2000	367.0	367.0	35.0

DGK (S-PDSO-G8)

PLASTIC SMALL-OUTLINE PACKAGE

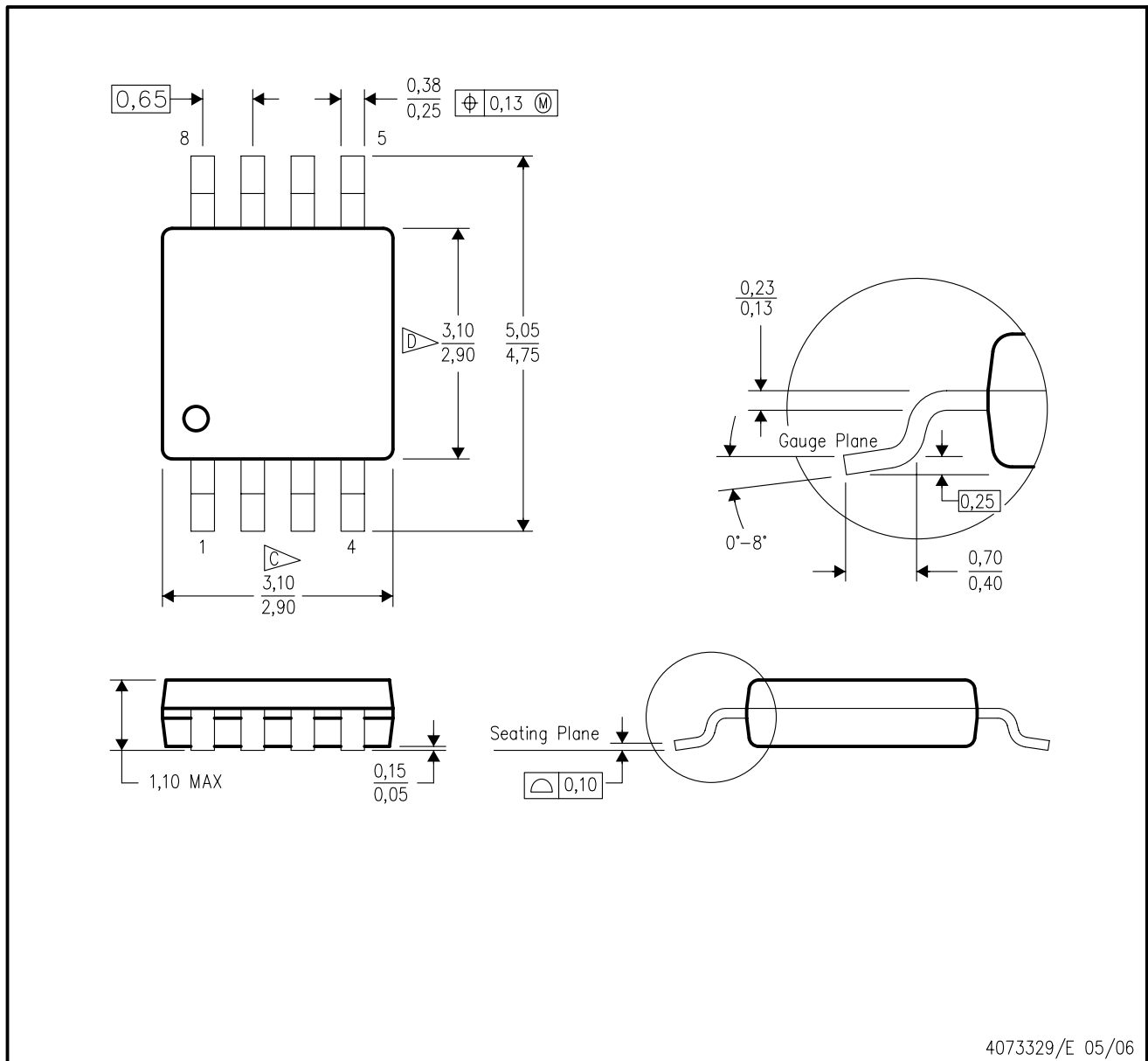

- NOTES:
- A. All linear dimensions are in millimeters.
  - B. This drawing is subject to change without notice.
  - C. Body length does not include mold flash, protrusions, or gate burrs. Mold flash, protrusions, or gate burrs shall not exceed 0.15 per end.
  - D. Body width does not include interlead flash. Interlead flash shall not exceed 0.50 per side.
  - E. Falls within JEDEC MO-187 variation AA, except interlead flash.

D (R-PDSO-G14)

PLASTIC SMALL OUTLINE

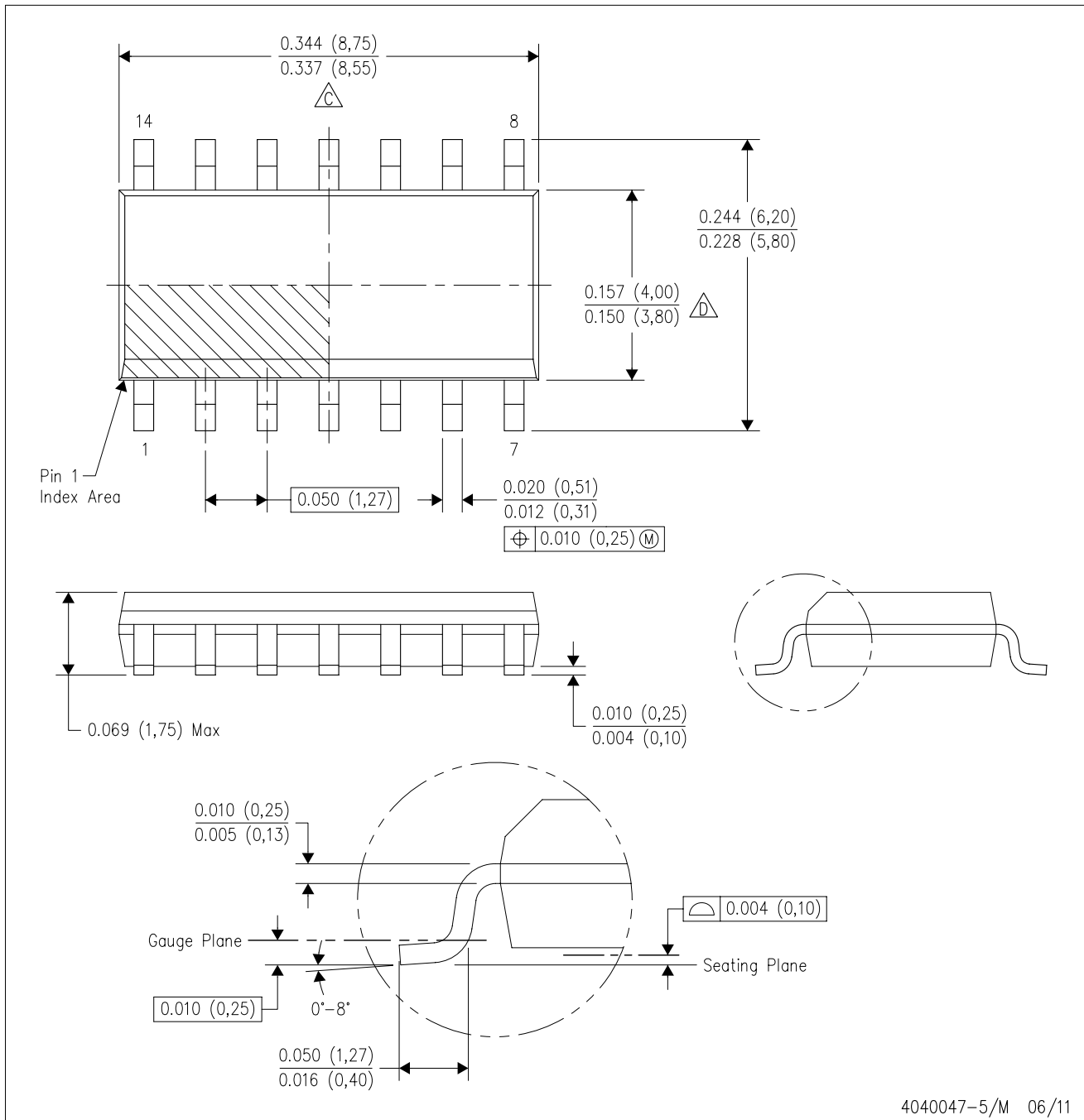

- NOTES:
- A. All linear dimensions are in inches (millimeters).
  - B. This drawing is subject to change without notice.
  - Body length does not include mold flash, protrusions, or gate burrs. Mold flash, protrusions, or gate burrs shall not exceed 0.006 (0,15) each side.
  - Body width does not include interlead flash. Interlead flash shall not exceed 0.017 (0,43) each side.
  - E. Reference JEDEC MS-012 variation AB.

D (R-PDSO-G14)

PLASTIC SMALL OUTLINE

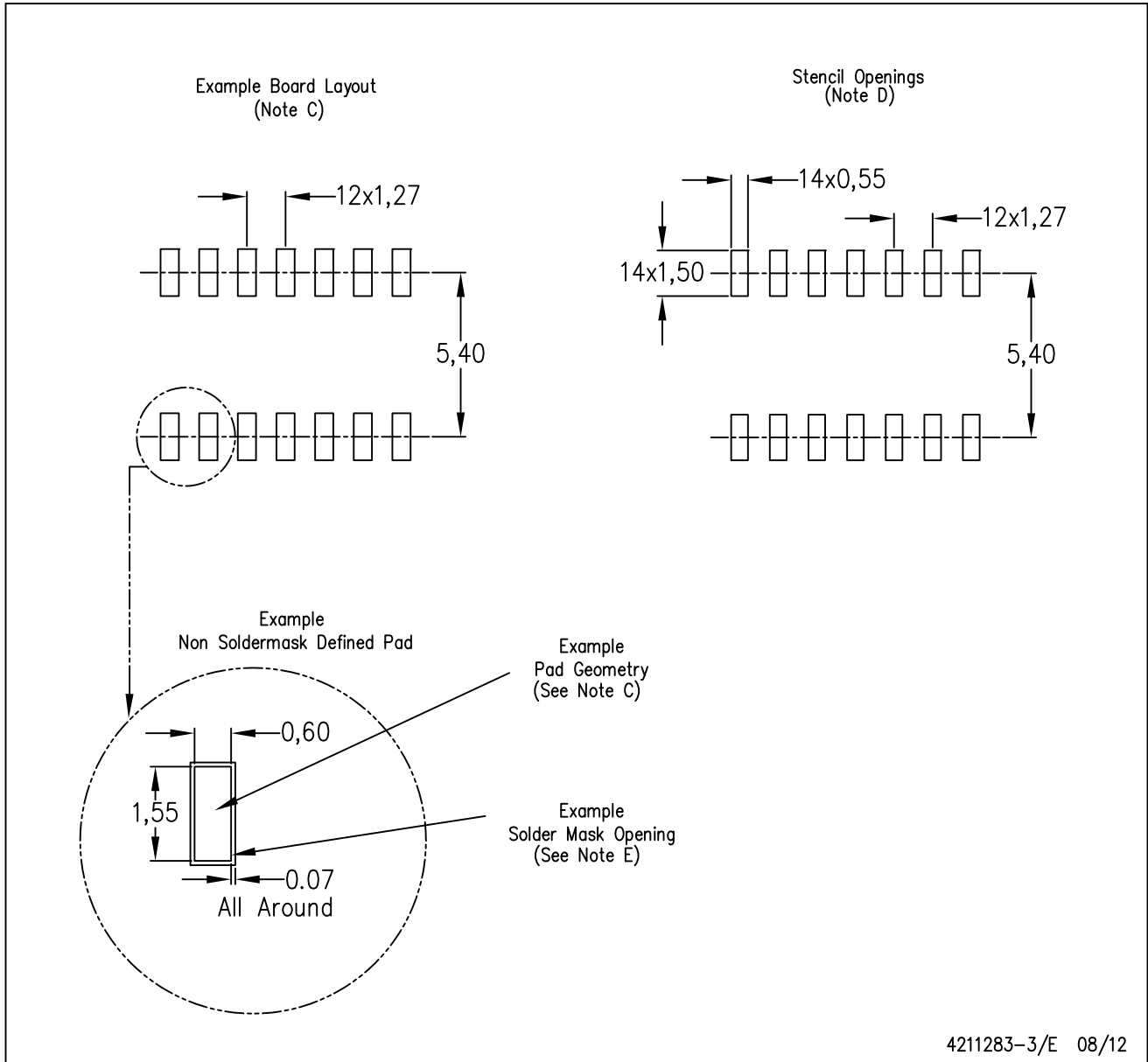

- NOTES:
- A. All linear dimensions are in millimeters.
  - B. This drawing is subject to change without notice.
  - C. Publication IPC-7351 is recommended for alternate designs.
  - D. Laser cutting apertures with trapezoidal walls and also rounding corners will offer better paste release. Customers should contact their board assembly site for stencil design recommendations. Refer to IPC-7525 for other stencil recommendations.
  - E. Customers should contact their board fabrication site for solder mask tolerances between and around signal pads.

D (R-PDSO-G16)

PLASTIC SMALL OUTLINE



4040047-6/M 06/11

- NOTES:
- A. All linear dimensions are in inches (millimeters).
  - B. This drawing is subject to change without notice.
  -  Body length does not include mold flash, protrusions, or gate burrs. Mold flash, protrusions, or gate burrs shall not exceed 0.006 (0,15) each side.
  -  Body width does not include interlead flash. Interlead flash shall not exceed 0.017 (0,43) each side.
  - E. Reference JEDEC MS-012 variation AC.

D (R-PDSO-G16)

PLASTIC SMALL OUTLINE



- NOTES:
- All linear dimensions are in millimeters.
  - This drawing is subject to change without notice.
  - Publication IPC-7351 is recommended for alternate designs.
  - Laser cutting apertures with trapezoidal walls and also rounding corners will offer better paste release. Customers should contact their board assembly site for stencil design recommendations. Refer to IPC-7525 for other stencil recommendations.
  - Customers should contact their board fabrication site for solder mask tolerances between and around signal pads.



PW (R-PDSO-G14)

PLASTIC SMALL OUTLINE

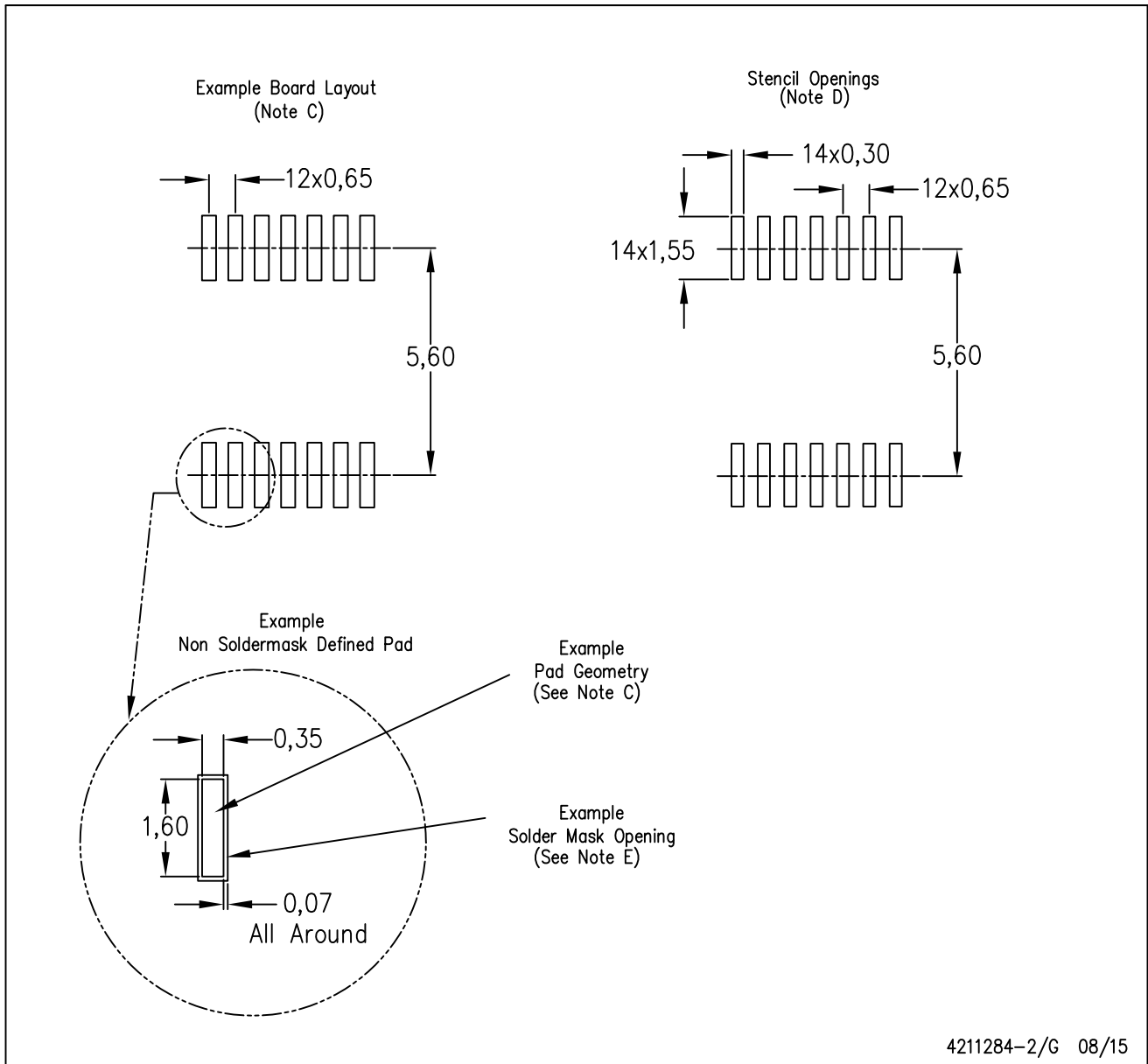

4211284-2/G 08/15



- NOTES:
- A. All linear dimensions are in millimeters.
  - B. This drawing is subject to change without notice.
  - C. Publication IPC-7351 is recommended for alternate designs.
  - D. Laser cutting apertures with trapezoidal walls and also rounding corners will offer better paste release. Customers should contact their board assembly site for stencil design recommendations. Refer to IPC-7525 for other stencil recommendations.
  - E. Customers should contact their board fabrication site for solder mask tolerances between and around signal pads.

PW (R-PDSO-G16)

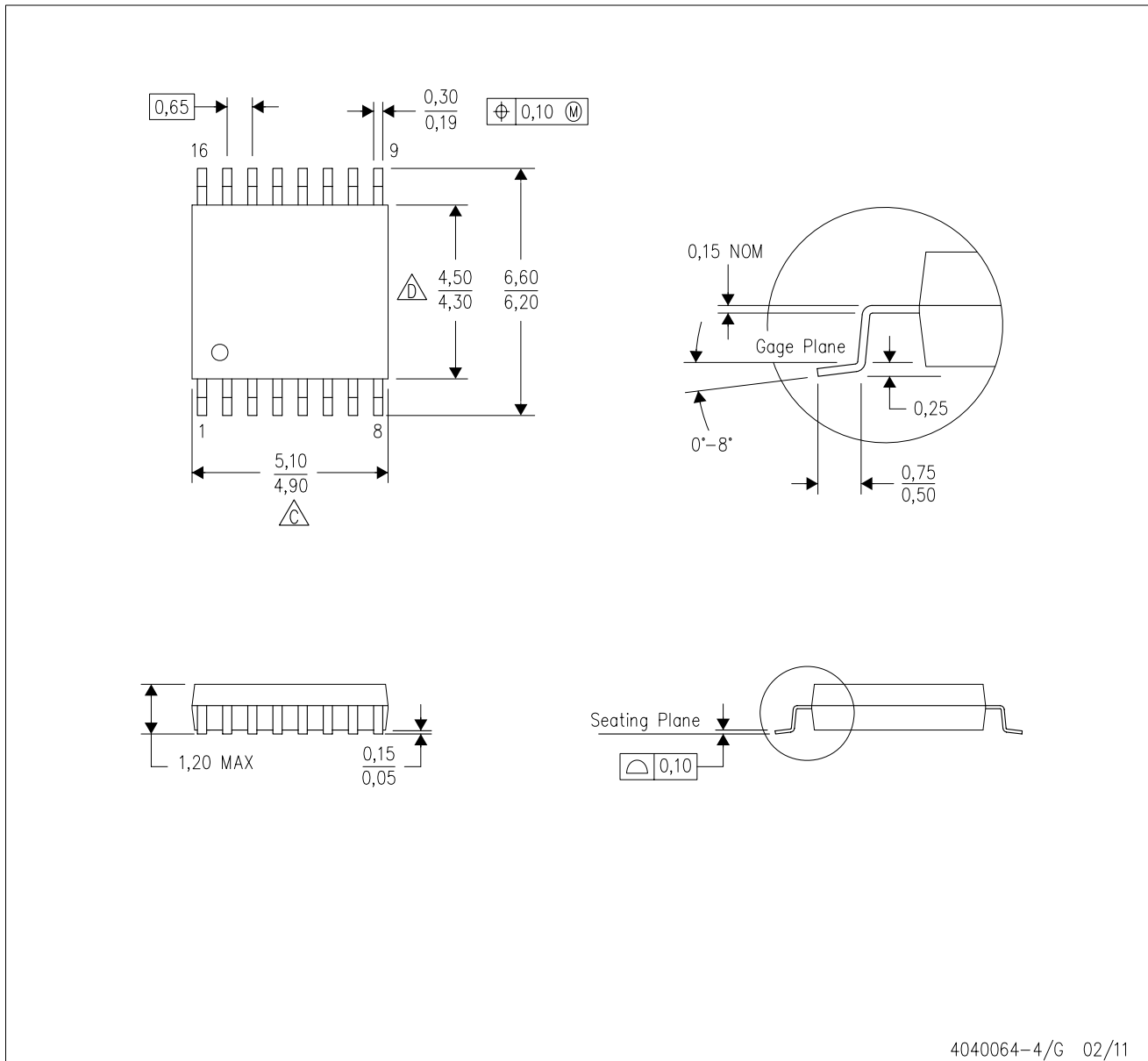
PLASTIC SMALL OUTLINE



4040064-4/G 02/11

- NOTES:
- A. All linear dimensions are in millimeters. Dimensioning and tolerancing per ASME Y14.5M-1994.
  - B. This drawing is subject to change without notice.
  -  Body length does not include mold flash, protrusions, or gate burrs. Mold flash, protrusions, or gate burrs shall not exceed 0,15 each side.
  -  Body width does not include interlead flash. Interlead flash shall not exceed 0,25 each side.
  - E. Falls within JEDEC MO-153

PW (R-PDSO-G16)

PLASTIC SMALL OUTLINE

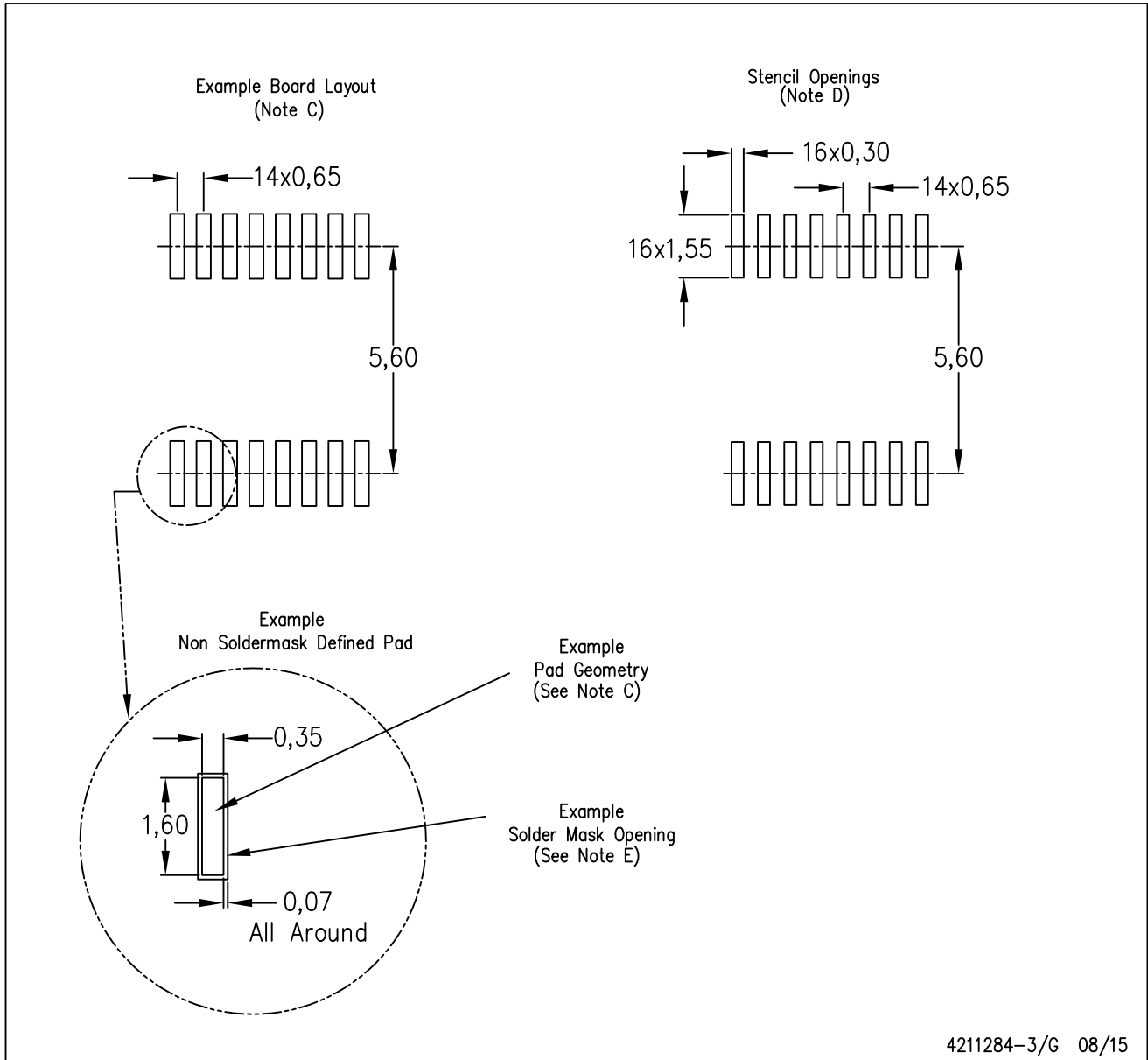

4211284-3/G 08/15

- NOTES:
- All linear dimensions are in millimeters.
  - This drawing is subject to change without notice.
  - Publication IPC-7351 is recommended for alternate designs.
  - Laser cutting apertures with trapezoidal walls and also rounding corners will offer better paste release. Customers should contact their board assembly site for stencil design recommendations. Refer to IPC-7525 for other stencil recommendations.
  - Customers should contact their board fabrication site for solder mask tolerances between and around signal pads.

D (R-PDSO-G8)

PLASTIC SMALL OUTLINE

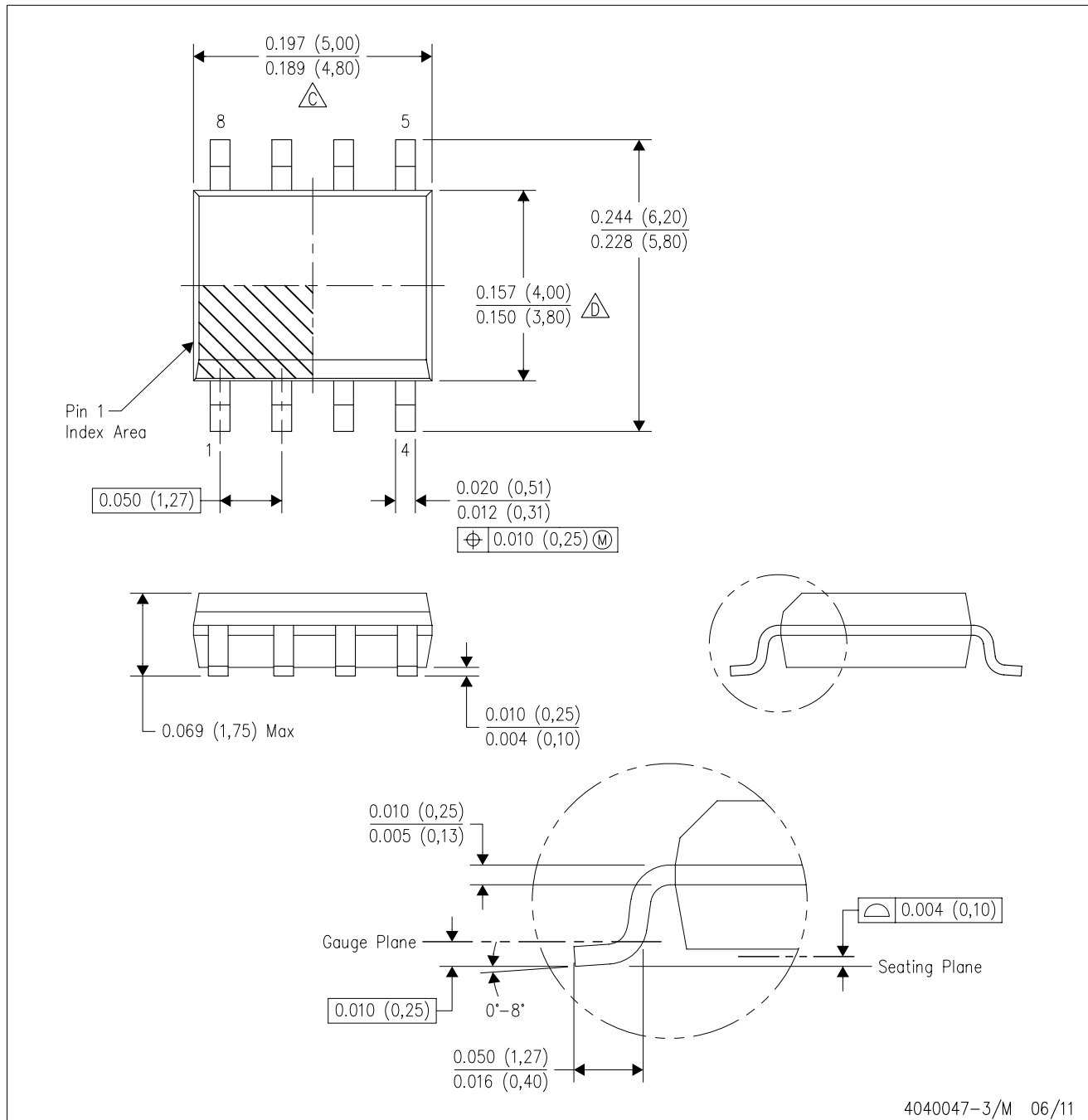

- NOTES:
- A. All linear dimensions are in inches (millimeters).
  - B. This drawing is subject to change without notice.
  - C. Body length does not include mold flash, protrusions, or gate burrs. Mold flash, protrusions, or gate burrs shall not exceed 0.006 (0,15) each side.
  - D. Body width does not include interlead flash. Interlead flash shall not exceed 0.017 (0,43) each side.
  - E. Reference JEDEC MS-012 variation AA.

D (R-PDSO-G8)

PLASTIC SMALL OUTLINE

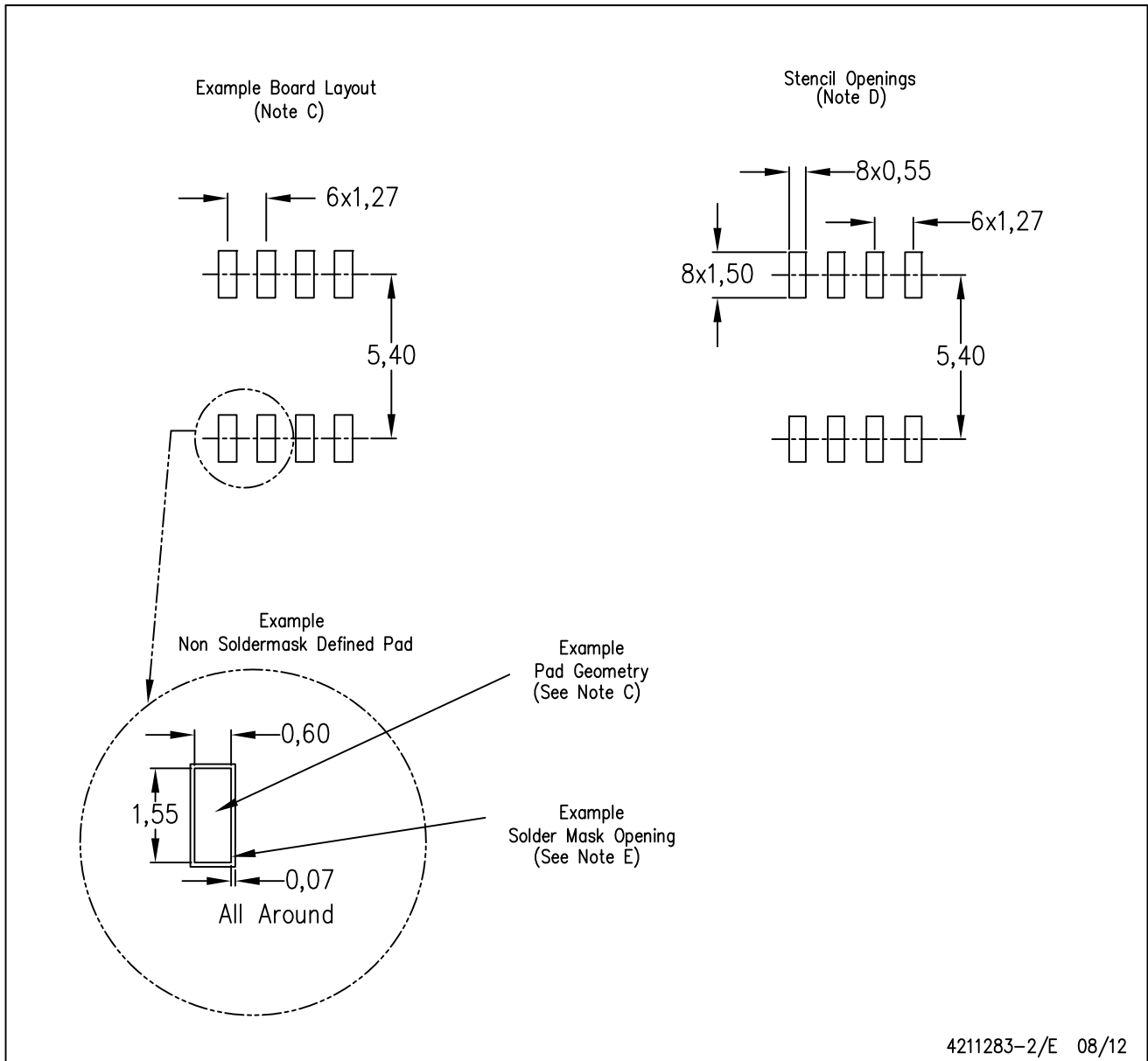

- NOTES:
- A. All linear dimensions are in millimeters.
  - B. This drawing is subject to change without notice.
  - C. Publication IPC-7351 is recommended for alternate designs.
  - D. Laser cutting apertures with trapezoidal walls and also rounding corners will offer better paste release. Customers should contact their board assembly site for stencil design recommendations. Refer to IPC-7525 for other stencil recommendations.
  - E. Customers should contact their board fabrication site for solder mask tolerances between and around signal pads.

## IMPORTANT NOTICE

Texas Instruments Incorporated and its subsidiaries (TI) reserve the right to make corrections, enhancements, improvements and other changes to its semiconductor products and services per JESD46, latest issue, and to discontinue any product or service per JESD48, latest issue. Buyers should obtain the latest relevant information before placing orders and should verify that such information is current and complete. All semiconductor products (also referred to herein as "components") are sold subject to TI's terms and conditions of sale supplied at the time of order acknowledgment.

TI warrants performance of its components to the specifications applicable at the time of sale, in accordance with the warranty in TI's terms and conditions of sale of semiconductor products. Testing and other quality control techniques are used to the extent TI deems necessary to support this warranty. Except where mandated by applicable law, testing of all parameters of each component is not necessarily performed.

TI assumes no liability for applications assistance or the design of Buyers' products. Buyers are responsible for their products and applications using TI components. To minimize the risks associated with Buyers' products and applications, Buyers should provide adequate design and operating safeguards.

TI does not warrant or represent that any license, either express or implied, is granted under any patent right, copyright, mask work right, or other intellectual property right relating to any combination, machine, or process in which TI components or services are used. Information published by TI regarding third-party products or services does not constitute a license to use such products or services or a warranty or endorsement thereof. Use of such information may require a license from a third party under the patents or other intellectual property of the third party, or a license from TI under the patents or other intellectual property of TI.

Reproduction of significant portions of TI information in TI data books or data sheets is permissible only if reproduction is without alteration and is accompanied by all associated warranties, conditions, limitations, and notices. TI is not responsible or liable for such altered documentation. Information of third parties may be subject to additional restrictions.

Resale of TI components or services with statements different from or beyond the parameters stated by TI for that component or service voids all express and any implied warranties for the associated TI component or service and is an unfair and deceptive business practice. TI is not responsible or liable for any such statements.

Buyer acknowledges and agrees that it is solely responsible for compliance with all legal, regulatory and safety-related requirements concerning its products, and any use of TI components in its applications, notwithstanding any applications-related information or support that may be provided by TI. Buyer represents and agrees that it has all the necessary expertise to create and implement safeguards which anticipate dangerous consequences of failures, monitor failures and their consequences, lessen the likelihood of failures that might cause harm and take appropriate remedial actions. Buyer will fully indemnify TI and its representatives against any damages arising out of the use of any TI components in safety-critical applications.

In some cases, TI components may be promoted specifically to facilitate safety-related applications. With such components, TI's goal is to help enable customers to design and create their own end-product solutions that meet applicable functional safety standards and requirements. Nonetheless, such components are subject to these terms.

No TI components are authorized for use in FDA Class III (or similar life-critical medical equipment) unless authorized officers of the parties have executed a special agreement specifically governing such use.

Only those TI components which TI has specifically designated as military grade or "enhanced plastic" are designed and intended for use in military/aerospace applications or environments. Buyer acknowledges and agrees that any military or aerospace use of TI components which have **not** been so designated is solely at the Buyer's risk, and that Buyer is solely responsible for compliance with all legal and regulatory requirements in connection with such use.

TI has specifically designated certain components as meeting ISO/TS16949 requirements, mainly for automotive use. In any case of use of non-designated products, TI will not be responsible for any failure to meet ISO/TS16949.

### Products

Audio	<a href="http://www.ti.com/audio">www.ti.com/audio</a>
Amplifiers	<a href="http://amplifier.ti.com">amplifier.ti.com</a>
Data Converters	<a href="http://dataconverter.ti.com">dataconverter.ti.com</a>
DLP® Products	<a href="http://www.dlp.com">www.dlp.com</a>
DSP	<a href="http://dsp.ti.com">dsp.ti.com</a>
Clocks and Timers	<a href="http://www.ti.com/clocks">www.ti.com/clocks</a>
Interface	<a href="http://interface.ti.com">interface.ti.com</a>
Logic	<a href="http://logic.ti.com">logic.ti.com</a>
Power Mgmt	<a href="http://power.ti.com">power.ti.com</a>
Microcontrollers	<a href="http://microcontroller.ti.com">microcontroller.ti.com</a>
RFID	<a href="http://www.ti-rfid.com">www.ti-rfid.com</a>
OMAP Applications Processors	<a href="http://www.ti.com/omap">www.ti.com/omap</a>
Wireless Connectivity	<a href="http://www.ti.com/wirelessconnectivity">www.ti.com/wirelessconnectivity</a>

### Applications

Automotive and Transportation	<a href="http://www.ti.com/automotive">www.ti.com/automotive</a>
Communications and Telecom	<a href="http://www.ti.com/communications">www.ti.com/communications</a>
Computers and Peripherals	<a href="http://www.ti.com/computers">www.ti.com/computers</a>
Consumer Electronics	<a href="http://www.ti.com/consumer-apps">www.ti.com/consumer-apps</a>
Energy and Lighting	<a href="http://www.ti.com/energy">www.ti.com/energy</a>
Industrial	<a href="http://www.ti.com/industrial">www.ti.com/industrial</a>
Medical	<a href="http://www.ti.com/medical">www.ti.com/medical</a>
Security	<a href="http://www.ti.com/security">www.ti.com/security</a>
Space, Avionics and Defense	<a href="http://www.ti.com/space-avionics-defense">www.ti.com/space-avionics-defense</a>
Video and Imaging	<a href="http://www.ti.com/video">www.ti.com/video</a>

### TI E2E Community

[e2e.ti.com](http://e2e.ti.com)