

HIGH-SPEED DIFFERENTIAL LINE DRIVERS AND RECEIVERS

FEATURES

- Typically Meets or Exceeds ANSI TIA/EIA-644-1995 Standard
- Operates From a Single 2.4-V to 3.6-V Supply
- Signaling Rates up to 400 Mbit/s
- Bus-Terminal ESD Exceeds 12 kV
- Low-Voltage Differential Signaling With Typical Output Voltages of 285 mV and a 100-Ω Load
- Propagation Delay Times
 - Driver: 1.7-ns Typical
 - Receiver: 3.7-ns Typical
 - Driver: 25-mW Typical
 - Receiver: 60-mW Typical
- Power Dissipation at 200 MHz
 - Driver: 25-mW Typical
 - Receiver: 60-mW Typical
- LVTTTL Input Levels Are 5-V Tolerant
- Receiver Maintains High Input Impedance
- Receiver Has Open-Circuit Fail Safe
- Available in Thin Shrink Outline Packaging With 20-mil Lead Pitch

DESCRIPTION

The SN65LVDS1050 is similar to the SN65LVDS050 except that it is characterized for operation with a lower supply voltage range and packaged in the thin shrink outline package for portable battery-powered applications.

The differential line drivers and receivers use low-voltage differential signaling (LVDS) to achieve signaling rates as high as 400 Mbps. The drivers provide a minimum differential output voltage magnitude of 247 mV into a 100-Ω load and receipt of 100-mV signals with up to 1 V of ground potential difference between a transmitter and receiver.

The intended application of this device and signaling technique is for point-to-point baseband data transmission over controlled impedance media of approximately 100-Ω characteristic impedance. The transmission media may be printed-circuit board traces, backplanes, or cables. Note: The ultimate rate and distance of data transfer is dependent upon the attenuation characteristics of the media, the noise coupling to the environment and other application-specific characteristics.

The SN65LVDS1050 is characterized for operation from -40°C to 85°C.

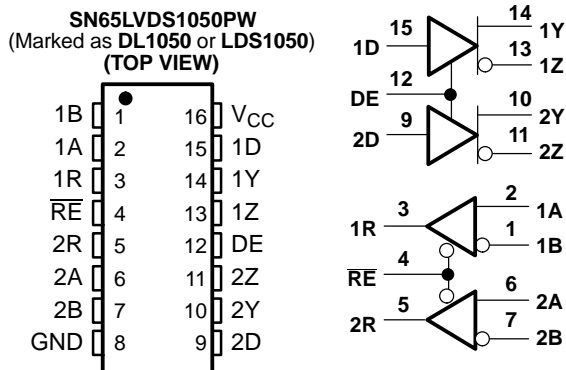

DRIVER FUNCTION TABLE

INPUTS		OUTPUTS	
D	DE	Y	Z
L	H	L	H
H	H	H	L
Open	H	L	H
X	L	Z	Z

H = high level, L = low level, Z = high impedance, X = don't care

RECEIVER FUNCTION TABLE

INPUTS		OUTPUT
$V_{ID} = V_A - V_B$	\overline{RE}	R
$V_{ID} \geq 100$ mV	L	H
-100 mV < $V_{ID} < 100$ mV	L	?
$V_{ID} \leq -100$ mV	L	L
Open	L	H
X	H	Z

H = high level, L = low level, Z = high impedance, X = don't care



Please be aware that an important notice concerning availability, standard warranty, and use in critical applications of Texas Instruments semiconductor products and disclaimers thereto appears at the end of this data sheet.

EQUIVALENT INPUT AND OUTPUT SCHEMATIC DIAGRAMS

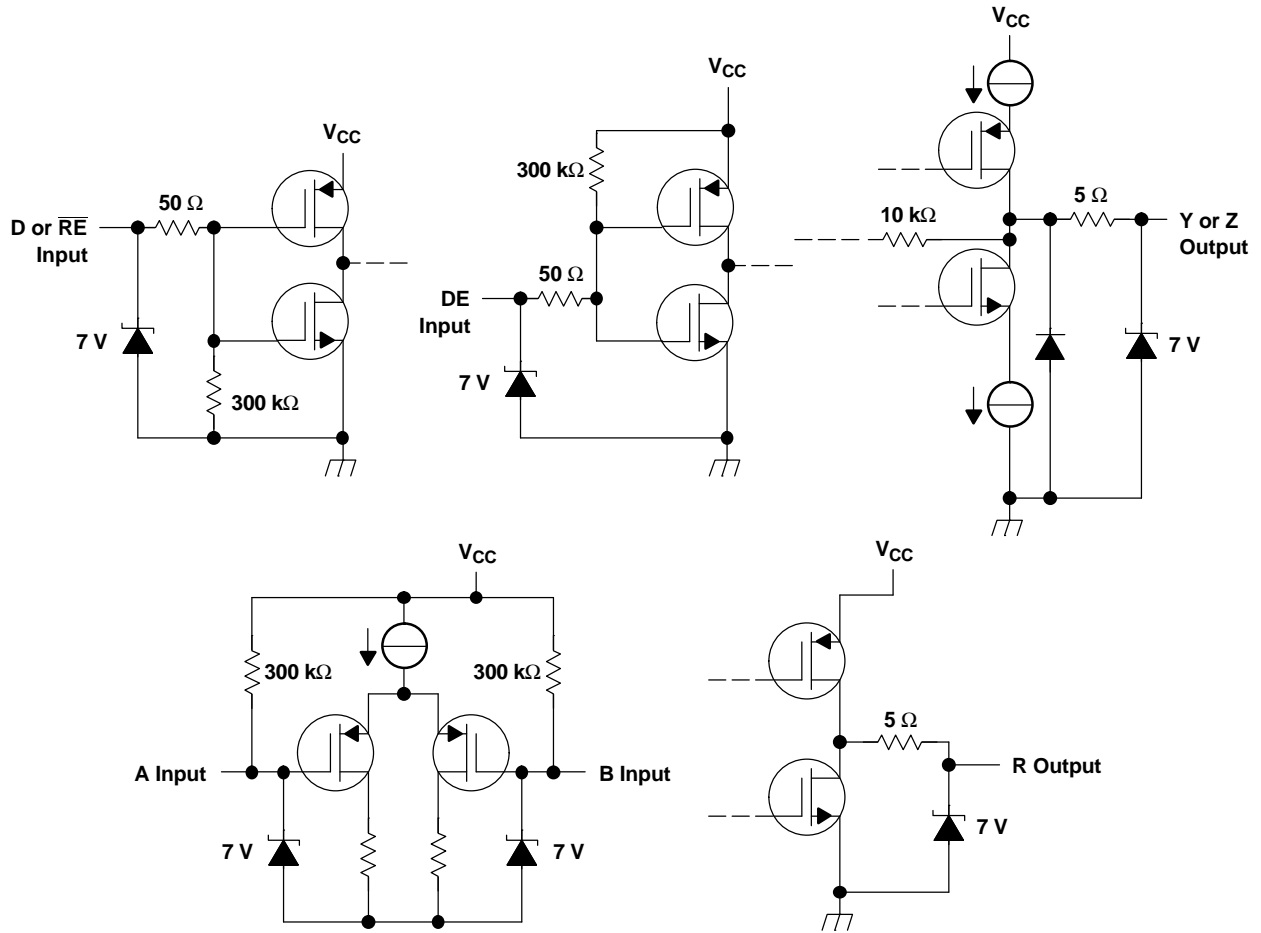

ABSOLUTE MAXIMUM RATINGS

over operating free-air temperature range (unless otherwise noted) (1)

		UNIT
Supply voltage range, V_{CC} (2)		-0.5 V to 4 V
Voltage range (D, R, DE, \overline{RE})		-0.5 V to 6 V
Voltage range (Y, Z, A, and B)		-0.5 V to 4 V
Electrostatic discharge	Y, Z, A, B , and GND (3)	Class 3, A:12 kV, B:600 V
	All terminals	Class 3, A:7 kV, B:500 V
Continuous power dissipation		See Dissipation Rating Table
Storage temperature range		-65°C to 150°C
Lead temperature 1,6 mm (1/16 inch) from case for 10 seconds		250°C

- (1) Stresses beyond those listed under "absolute maximum ratings" may cause permanent damage to the device. These are stress ratings only, and functional operation of the device at these or any other condition beyond those indicated under "recommended operating conditions" is not implied. Exposure to absolute-maximum-rated conditions for extended periods may affect device reliability.
- (2) All voltage values, except differential I/O bus voltages are with respect to network ground terminal.
- (3) Tested in accordance with MIL-STD-883C Method 3015.7.

DISSIPATION RATING TABLE

PACKAGE	$T_A \leq 25^\circ\text{C}$ POWER RATING	DERATING FACTOR ABOVE $T_A = 25^\circ\text{C}$	$T_A = 85^\circ\text{C}$ POWER RATING
PW	774 mW	6.2 mW/°C	402 mW

RECOMMENDED OPERATING CONDITIONS (1)

	MIN	NOM	MAX	UNIT
Supply voltage, V_{CC}	2.4	2.7	3.6	V
High-level input voltage, V_{IH}	2			V
Low-level input voltage, V_{IL}			0.8	V
Magnitude of differential input voltage, $ V_{ID} $	0.1		0.6	V
Driver output voltage, V_{OY} or V_{OZ}	0		2.4	V
Magnitude of differential output voltage with disabled driver, $ V_{OD(dis)} $			520	mV
Common-mode input voltage, V_{IC} (see Figure 5)	0		$2.4 - \frac{ V_{ID} }{2}$	V
			$V_{CC} - 0.8$	
Operating free-air temperature, T_A	40		85	°C

- (1) The common-mode input voltage, V_{IC} , is not fully 644 compliant when $V_{CC} = 2.4$ V.

DEVICE ELECTRICAL CHARACTERISTICS

over recommended operating conditions (unless otherwise noted)

PARAMETER	TEST CONDITIONS	MIN	TYP (1)	MAX	UNIT
I_{CC} Supply current	Driver and receiver enabled, No receiver load, Driver $R_L = 100 \Omega$		12	20	mA
	Driver enabled, Receiver disabled, $R_L = 100 \Omega$		10	16	
	Driver disabled, Receiver enabled, No load		3	6	
	Disabled		0.5	1	

- (1) All typical values are at 25°C and with a 2.7-V supply.

DRIVER ELECTRICAL CHARACTERISTICS

over recommended operating conditions (unless otherwise noted)

PARAMETER		TEST CONDITIONS	MIN	TYP	MAX	UNIT
$ V_{OD} $	Differential output voltage magnitude	$R_L=100\Omega$, See Figure 1 and Figure 2	247	285	454	mV
$\Delta V_{OD} $	Change in differential output voltage magnitude between logic states		50		50	
$V_{OC(SS)}$	Steady-state common-mode output voltage	See Figure 3	1.125		1.375	V
$\Delta V_{OC(SS)}$	Change in steady-state common-mode output voltage between logic states		50		50	mV
$V_{OC(PP)}$	Peak-to-peak common-mode output voltage			50	150	mV
I_{IH}	High-level input current	DE	$V_{IH}=5\text{ V}$	0.5	20	μA
		D		2	20	
I_{IL}	Low-level input current	DE	$V_{IL}=0.8\text{ V}$	0.5	10	μA
		D		2	20	
I_{OS}	Short-circuit output current	V_{OY} or $V_{OZ}=0\text{ V}$		3	10	mA
		$V_{OD}=0\text{ V}$		3	10	
$I_{O(OFF)}$	Off-state output current	$DE=0\text{ V}$, $V_{OY}=V_{OZ}=0\text{ V}$				μA
		$DE=V_{CC}$, $V_{OY}=V_{OZ}=0\text{ V}$, $V_{CC} < 1.5\text{ V}$	-1		1	
C_{IN}	Input capacitance			3		pF

RECEIVER ELECTRICAL CHARACTERISTICS

over recommended operating conditions (unless otherwise noted)

PARAMETER		TEST CONDITIONS	MIN	TYP (1)	MAX	UNIT
V_{ITH+}	Positive-going differential input voltage threshold	See Figure 5 and Table 1			100	mV
V_{ITH-}	Negative-going differential input voltage threshold		100			
V_{OH}	High-level output voltage	$I_{OH}=-8\text{ mA}$	2			V
V_{OL}	Low-level output voltage	$I_{OL}=8\text{ mA}$			0.4	V
I_I	Input current (A or B inputs)	$V_I=0$	2		20	μA
		$V_I=2.4\text{ V}$	1.2			
$I_{I(OFF)}$	Power-off input current (A or B inputs)	$V_{CC}=0$			± 20	μA
I_{IH}	High-level input current (enables)	$V_{IH}=5\text{ V}$			± 10	μA
I_{IL}	Low-level input current (enables)	$V_{IL}=0.8\text{ V}$			± 10	μA
I_{OZ}	High-impedance output current	$V_O = 0$ or 5 V			± 10	μA

(1) All typical values are at 25°C and with a 2.7-V supply.

DRIVER SWITCHING CHARACTERISTICS

over recommended operating conditions (unless otherwise noted)

PARAMETER	TEST CONDITIONS	MIN	TYP (1)	MAX	UNIT
t_{PLH}	Propagation delay time, low-to-high-level output		1.7	2.7	ns
t_{PHL}	Propagation delay time, high-to-low-level output		1.7	3	ns
t_r	Differential output signal rise time	$R_L=100\Omega$, $C_L=10$ pF, See Figure 2	0.8	1	ns
t_f	Differential output signal fall time		0.8	1	ns
$t_{sk(p)}$	Pulse skew ($t_{pHL} - t_{pLH}$)		300		ps
$t_{sk(o)}$	Channel-to-channel output skew (2)		150		ps
t_{en}	Enable time	See Figure 4	7.8	10	ns
t_{dis}	Disable time		6.6	10	ns

(1) All typical values are at 25°C and with a 2.7-V supply.

(2) $t_{sk(o)}$ is the maximum delay time difference between drivers on the same device.

RECEIVER SWITCHING CHARACTERISTICS

over recommended operating conditions (unless otherwise noted)

PARAMETER	TEST CONDITIONS	MIN	TYP (1)	MAX	UNIT
t_{PLH}	Propagation delay time, low-to-high-level output	$C_L=10$ pF, See Figure 6	3.7	5.2	ns
t_{PHL}	Propagation delay time, high-to-low-level output		3.7	4.5	ns
$t_{sk(p)}$	Pulse skew ($t_{pHL} - t_{pLH}$)		0.3		ns
t_r	Output signal rise time		0.8	1.5	ns
t_f	Output signal fall time		0.8	1.5	ns
t_{PZH}	Propagation delay time, high-level-to-high-impedance output	See Figure 7	5.4		ns
t_{PZL}	Propagation delay time, low-level-to-low-impedance output		6.3		ns
t_{PHZ}	Propagation delay time, high-impedance-to-high-level output		6.1		ns
t_{PLZ}	Propagation delay time, low-impedance-to-high-level output		6.9		ns

(1) All typical values are at 25°C and with a 2.7-V supply.

PARAMETER MEASUREMENT INFORMATION

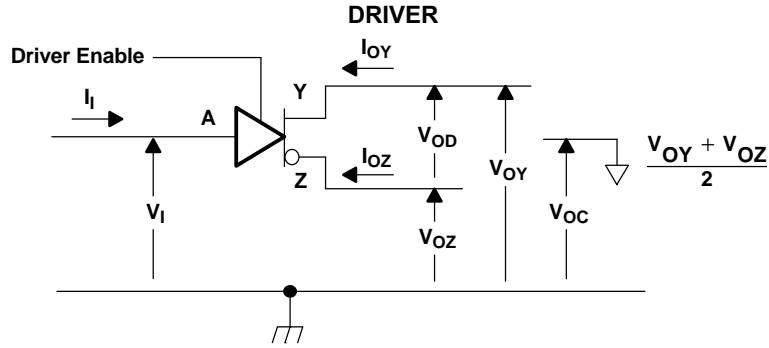
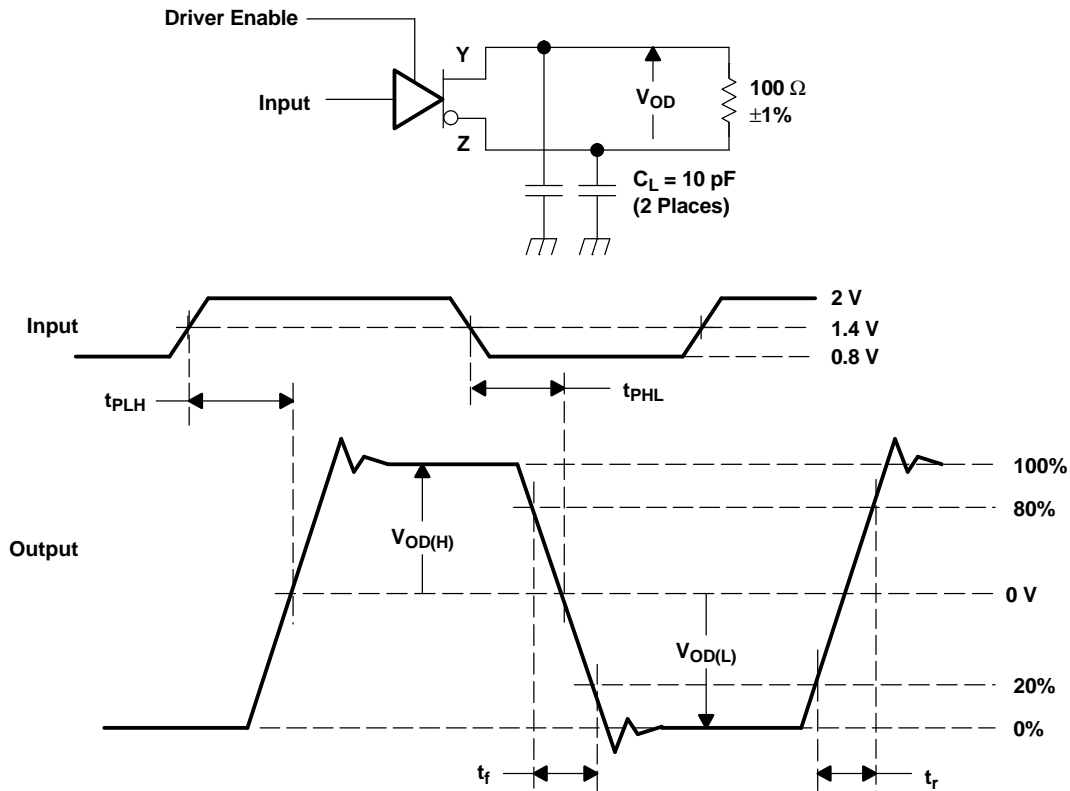
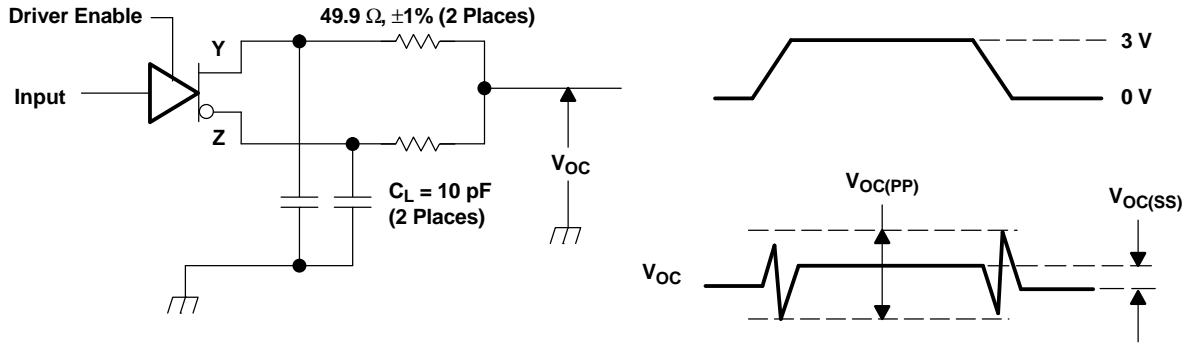

Figure 1. Driver Voltage and Current Definitions



All input pulses are supplied by a generator having the following characteristics: t_r or $t_f \leq 1$ ns, pulse repetition rate (PRR) = 50 Mpps, pulse width = 10 ± 0.2 ns. C_L includes instrumentation and fixture capacitance within 0,06 mm of the D.U.T.

Figure 2. Test Circuit, Timing, and Voltage Definitions for the Differential Output Signal



All input pulses are supplied by a generator having the following characteristics: t_r or $t_f \leq 1$ ns, pulse repetition rate (PRR) = 50 Mpps, pulse width = 10 ± 0.2 ns. C_L includes instrumentation and fixture capacitance within 0,06 mm of the D.U.T. The measurement of V_{Oc(PP)} is made on test equipment with a -3 dB bandwidth of at least 300 MHz.

Figure 3. Test Circuit and Definitions for the Driver Common-Mode Output Voltage

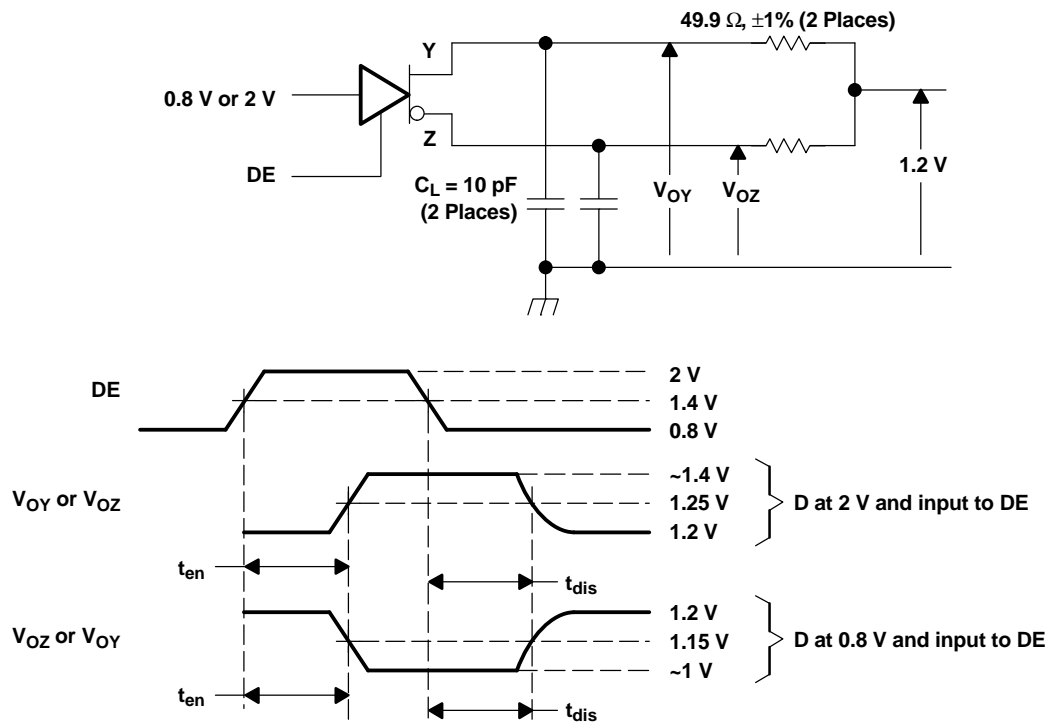

All input pulses are supplied by a generator having the following characteristics: t_r or $t_f \leq 1$ ns, pulse repetition rate (PRR) = 0.5 Mpps, pulse width = 500 ± 10 ns. C_L includes instrumentation and fixture capacitance within 0,06 mm of the D.U.T.

Figure 4. Driver Enable and Disable Time Circuit and Definitions

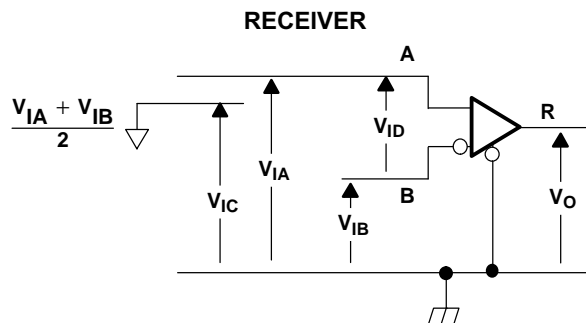
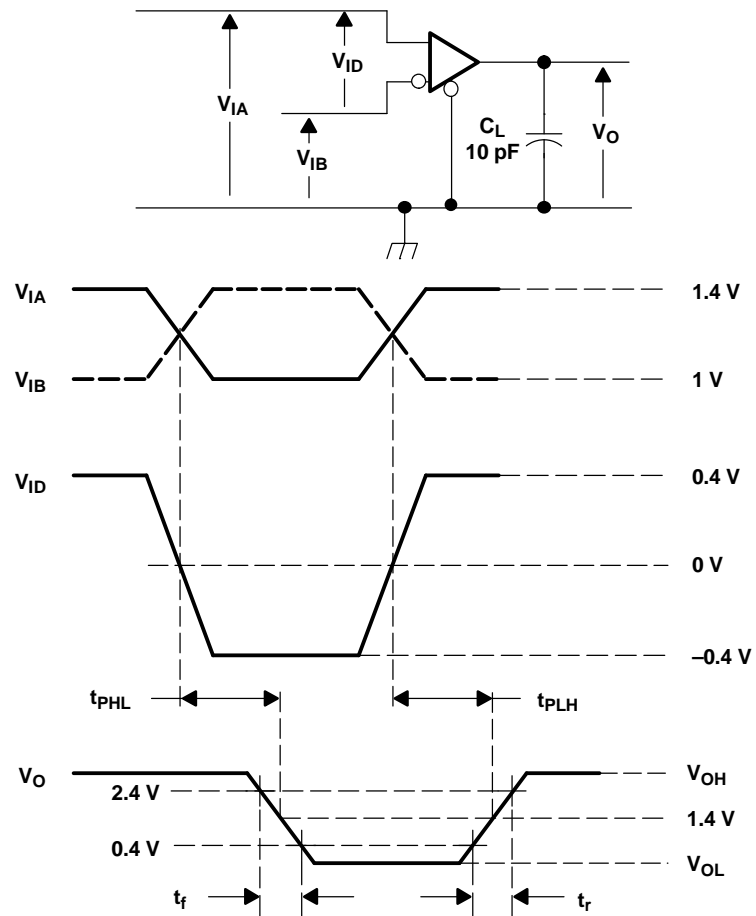

Figure 5. Receiver Voltage Definitions

Table 1. Receiver Minimum and Maximum Input Threshold Test Voltages

APPLIED VOLTAGES (V)		RESULTING DIFFERENTIAL INPUT VOLTAGE (mV)	RESULTING COMMON-MODE INPUT VOLTAGE (V)
V_{IA}	V_{IB}	V_{ID}	V_{IC}
1.25	1.15	100	1.2
1.15	1.25	100	1.2
2.4	2.3	100	2.35
2.3	2.4	100	2.35
0.1	0	100	0.05
0	0.1	100	0.05
1.5	0.9	600	1.2
0.9	1.5	600	1.2
2.4	1.8	600	2.1
1.8	2.4	600	2.1
0.6	0	600	0.3
0	0.6	600	0.3



All input pulses are supplied by a generator having the following characteristics: t_r or $t_f \leq 1 \text{ ns}$, pulse repetition rate (PRR) = 50 Mpps, pulse width = $10 \pm 0.2 \text{ ns}$. C_L includes instrumentation and fixture capacitance within 0,06 m of the D.U.T.

Figure 6. Timing Test Circuit and Waveforms

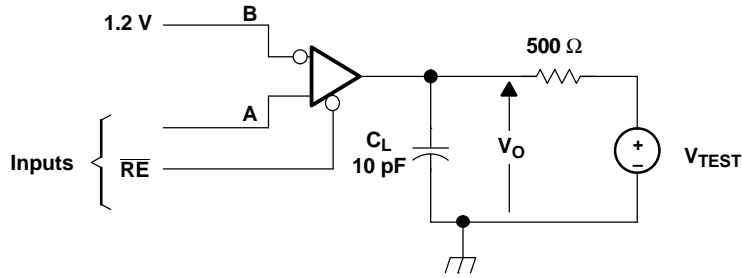

All input pulses are supplied by a generator having the following characteristics: t_r or $t_f \leq 1$ ns, pulse repetition rate (PRR) = 0.5 Mpps, pulse width = 500 ± 10 ns. C_L includes instrumentation and fixture capacitance within 0,06 m of the D.U.T.

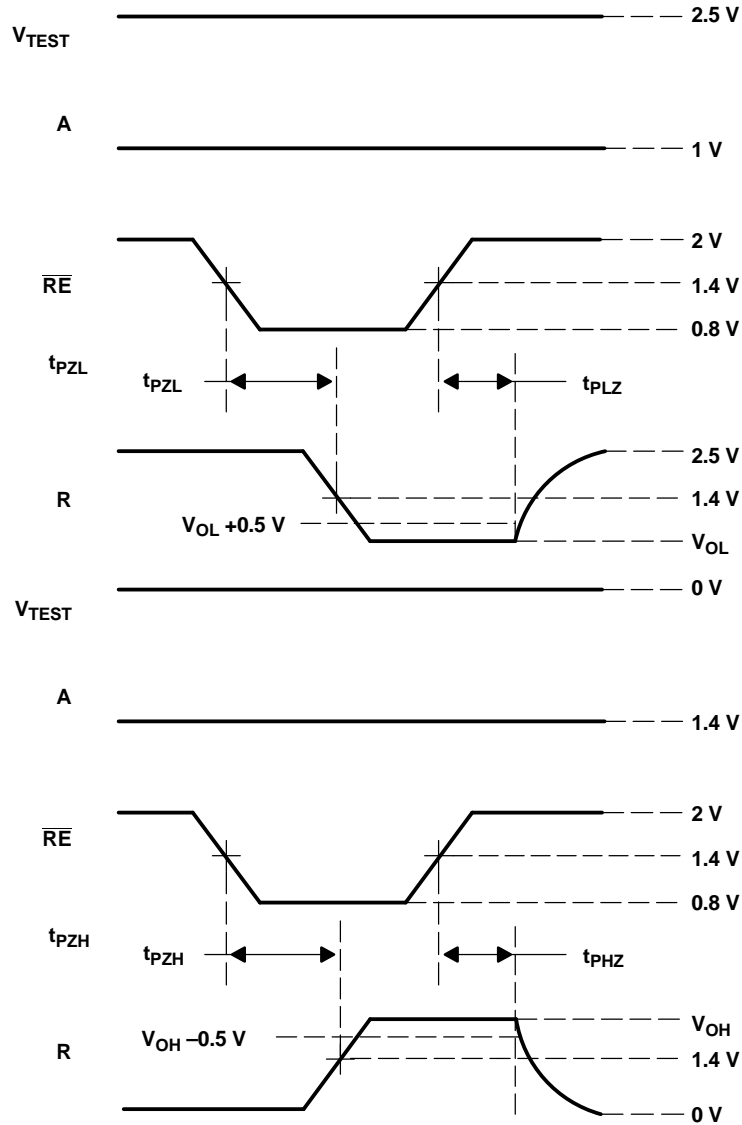

Figure 7. Enable/Disable Time Test Circuit and Waveforms

TYPICAL CHARACTERISTICS

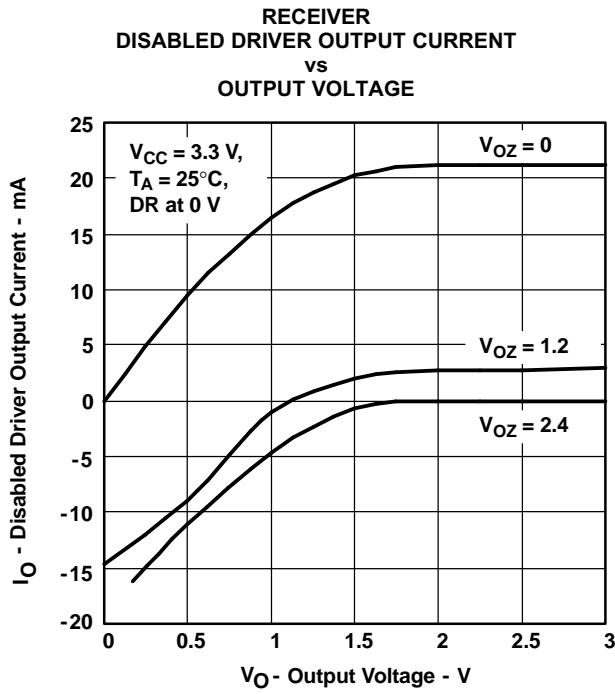

Figure 8.

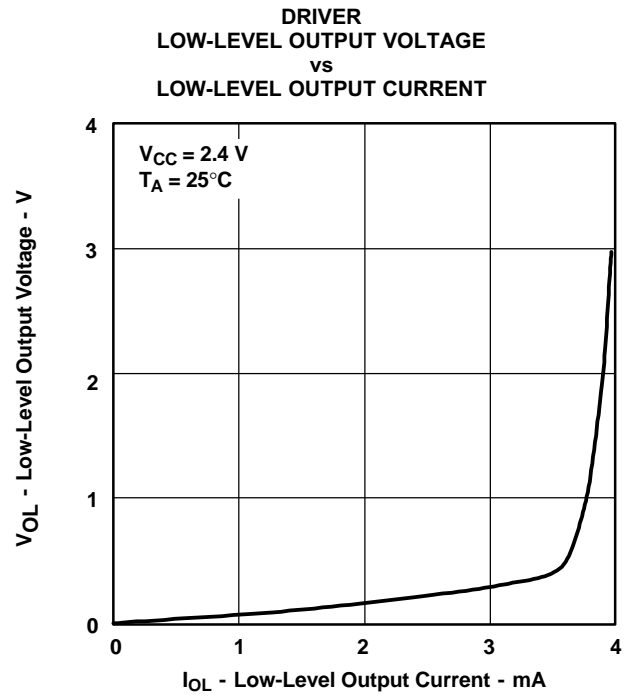

Figure 9.

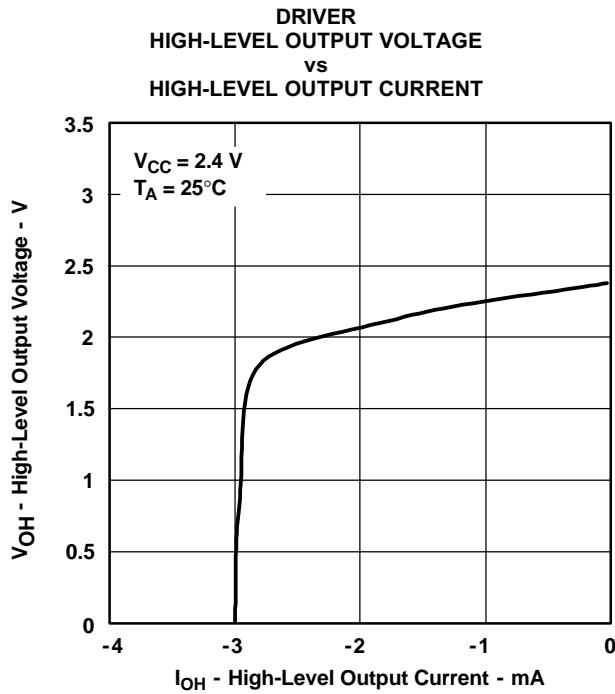

Figure 10.

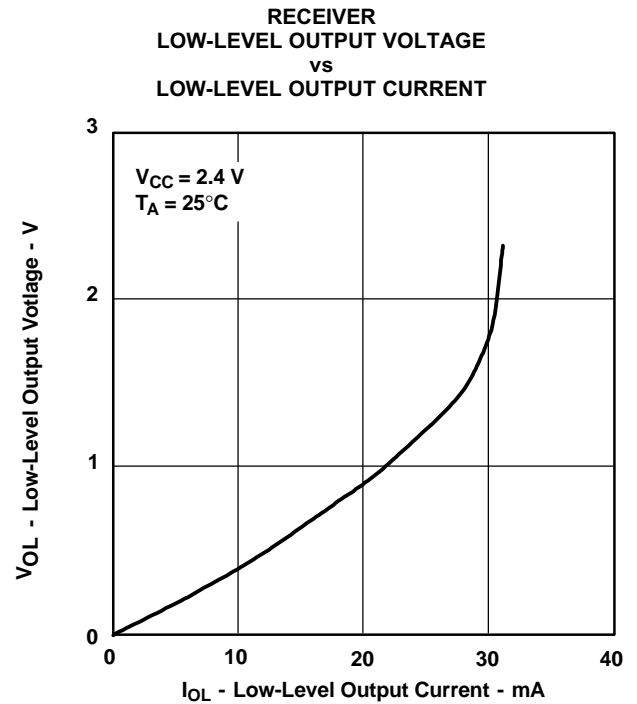

Figure 11.

RECEIVER
HIGH-LEVEL OUTPUT VOLTAGE
vs
HIGH-LEVEL OUTPUT CURRENT

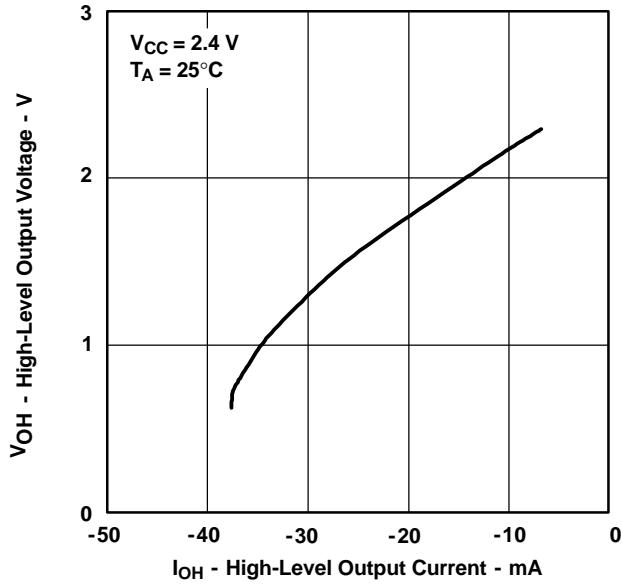

Figure 12.

DRIVER
HIGH-TO-LOW LEVEL PROPAGATION DELAY TIME
vs
FREE-AIR TEMPERATURE

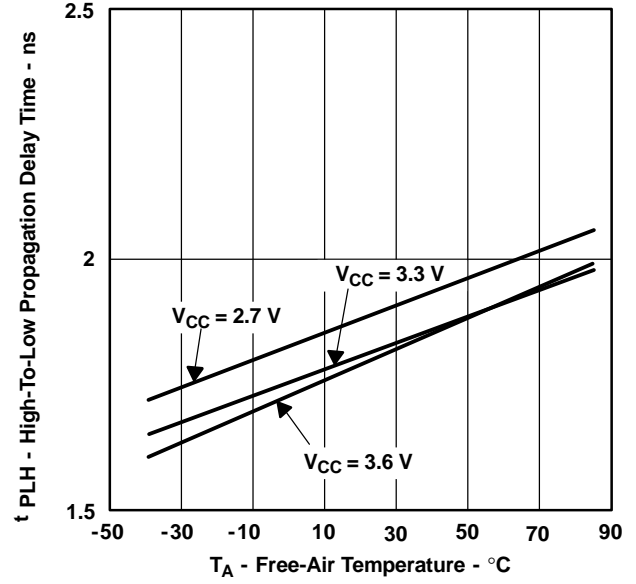

Figure 13.

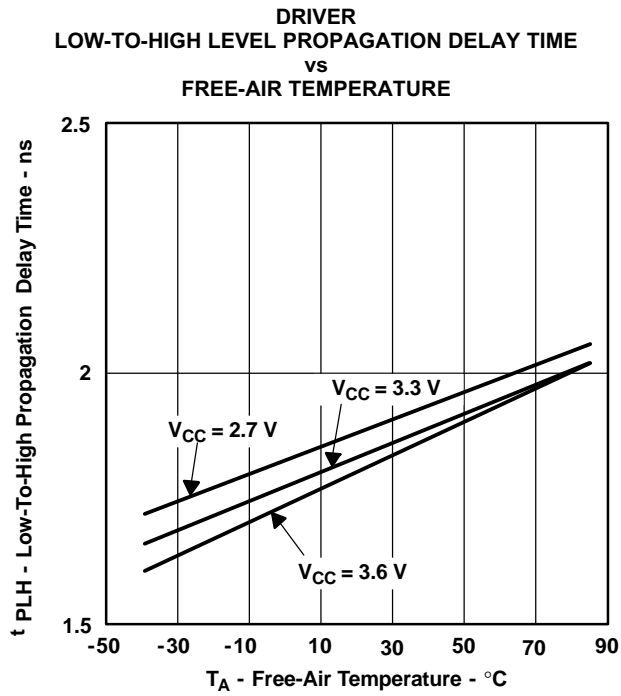

Figure 14.

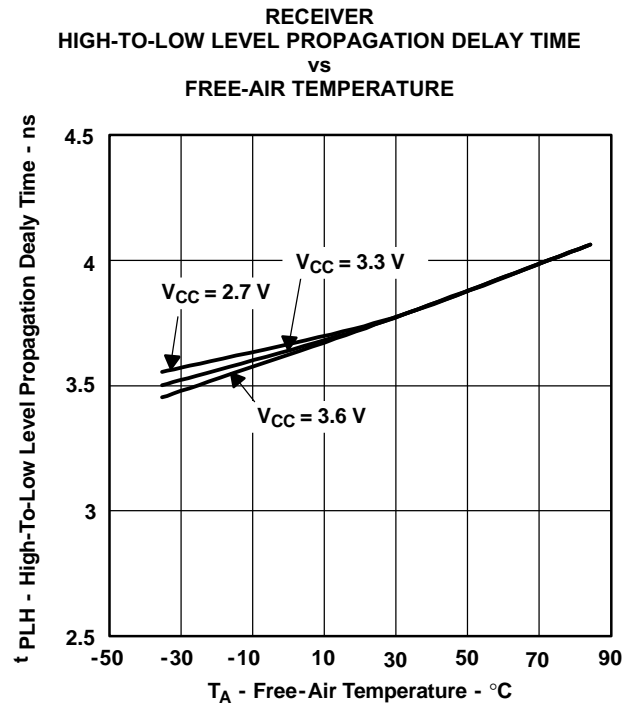

Figure 15.

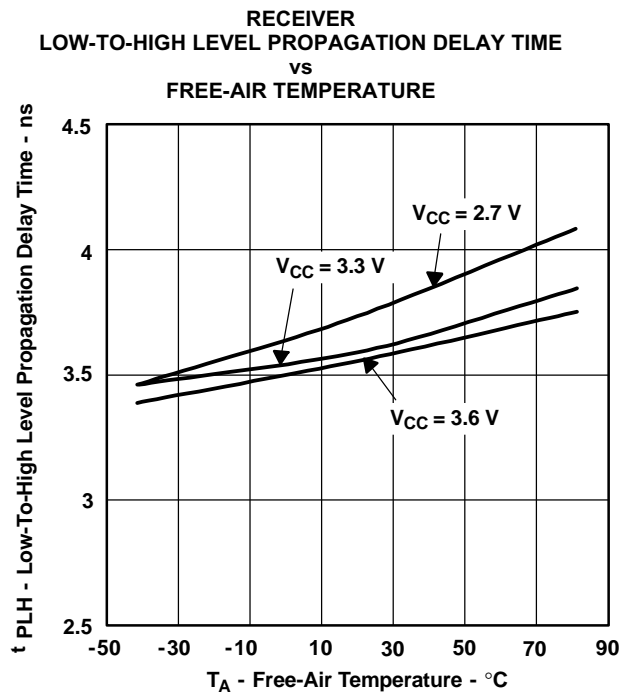

Figure 16

APPLICATION INFORMATION

The devices are generally used as building blocks for high-speed point-to-point data transmission. Ground differences are less than 1 V with a low common-mode output and balanced interface for very low noise emissions. Devices can interoperate with RS-422, PECL, and IEEE-P1596. Drivers/Receivers maintain ECL speeds without the power and dual supply requirements.

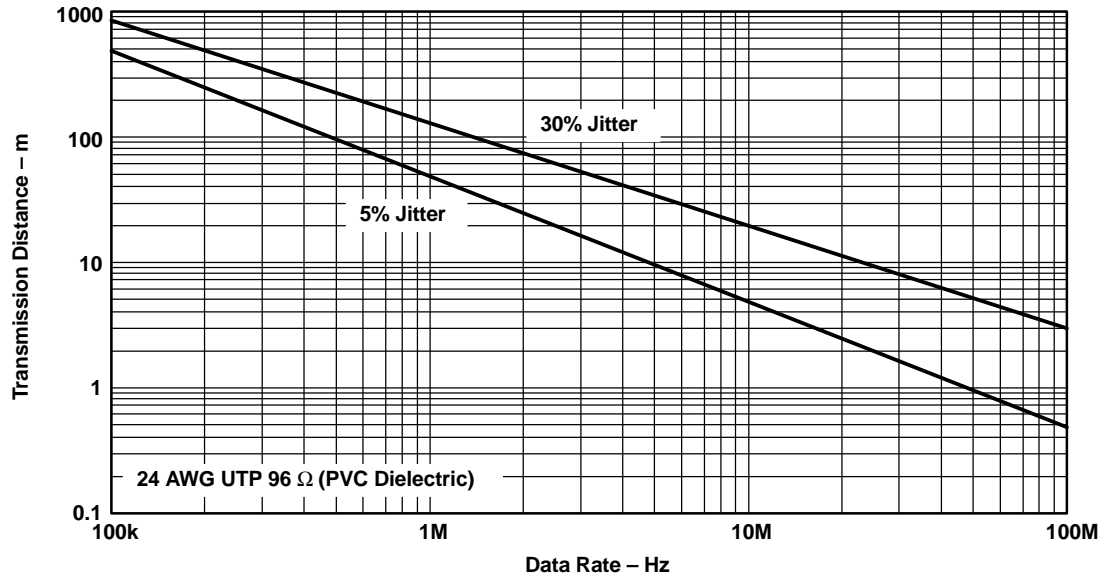

Figure 17. Data Transmission Distance Versus Rate

Fail Safe

One of the most common problems with differential signaling applications is how the system responds when no differential voltage is present on the signal pair. The LVDS receiver is like most differential line receivers, in that its output logic state can be indeterminate when the differential input voltage is between -100 mV and 100 mV and within its recommended input common-mode voltage range. TI's LVDS receiver is different in how it handles the open-input circuit situation, however.

Open-circuit means that there is little or no input current to the receiver from the data line itself. This could be when the driver is in a high-impedance state or the cable is disconnected. When this occurs, the LVDS receiver pulls each line of the signal pair to near V_{CC} through 300-k Ω resistors as shown in Figure 11. The fail-safe feature uses an AND gate with input voltage thresholds at about 2.3 V to detect this condition and force the output to a high-level, regardless of the differential input voltage.

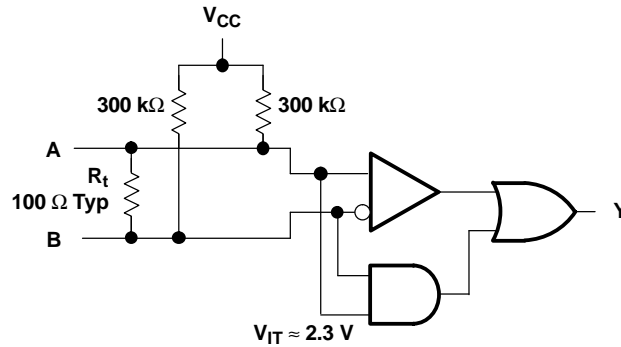

Figure 18. Open-Circuit Fail Safe of the LVDS Receiver

It is only under these conditions that the output of the receiver is valid with less than a 100-mV differential input voltage magnitude. The presence of the termination resistor, R_t , does not affect the fail-safe function as long as it is connected as shown in the figure. Other termination circuits may allow a dc current to ground that could defeat the pullup currents from the receiver and the fail-safe feature.

PACKAGING INFORMATION

Orderable Device	Status (1)	Package Type	Package Drawing	Pins	Package Qty	Eco Plan (2)	Lead/Ball Finish (6)	MSL Peak Temp (3)	Op Temp (°C)	Device Marking (4/5)	Samples
SN65LVDS1050PW	ACTIVE	TSSOP	PW	16	90	Green (RoHS & no Sb/Br)	CU NIPDAU	Level-1-260C-UNLIM	-40 to 85	DL1050	Samples
SN65LVDS1050PWG4	ACTIVE	TSSOP	PW	16	90	Green (RoHS & no Sb/Br)	CU NIPDAU	Level-1-260C-UNLIM	-40 to 85	DL1050	Samples
SN65LVDS1050PWR	ACTIVE	TSSOP	PW	16	2000	Green (RoHS & no Sb/Br)	CU NIPDAU	Level-1-260C-UNLIM	-40 to 85	DL1050	Samples

(1) The marketing status values are defined as follows:

ACTIVE: Product device recommended for new designs.

LIFEBUY: TI has announced that the device will be discontinued, and a lifetime-buy period is in effect.

NRND: Not recommended for new designs. Device is in production to support existing customers, but TI does not recommend using this part in a new design.

PREVIEW: Device has been announced but is not in production. Samples may or may not be available.

OBsolete: TI has discontinued the production of the device.

(2) Eco Plan - The planned eco-friendly classification: Pb-Free (RoHS), Pb-Free (RoHS Exempt), or Green (RoHS & no Sb/Br) - please check <http://www.ti.com/productcontent> for the latest availability information and additional product content details.

TBD: The Pb-Free/Green conversion plan has not been defined.

Pb-Free (RoHS): TI's terms "Lead-Free" or "Pb-Free" mean semiconductor products that are compatible with the current RoHS requirements for all 6 substances, including the requirement that lead not exceed 0.1% by weight in homogeneous materials. Where designed to be soldered at high temperatures, TI Pb-Free products are suitable for use in specified lead-free processes.

Pb-Free (RoHS Exempt): This component has a RoHS exemption for either 1) lead-based flip-chip solder bumps used between the die and package, or 2) lead-based die adhesive used between the die and leadframe. The component is otherwise considered Pb-Free (RoHS compatible) as defined above.

Green (RoHS & no Sb/Br): TI defines "Green" to mean Pb-Free (RoHS compatible), and free of Bromine (Br) and Antimony (Sb) based flame retardants (Br or Sb do not exceed 0.1% by weight in homogeneous material)

(3) MSL, Peak Temp. - The Moisture Sensitivity Level rating according to the JEDEC industry standard classifications, and peak solder temperature.

(4) There may be additional marking, which relates to the logo, the lot trace code information, or the environmental category on the device.

(5) Multiple Device Markings will be inside parentheses. Only one Device Marking contained in parentheses and separated by a "~" will appear on a device. If a line is indented then it is a continuation of the previous line and the two combined represent the entire Device Marking for that device.

(6) Lead/Ball Finish - Orderable Devices may have multiple material finish options. Finish options are separated by a vertical ruled line. Lead/Ball Finish values may wrap to two lines if the finish value exceeds the maximum column width.

Important Information and Disclaimer: The information provided on this page represents TI's knowledge and belief as of the date that it is provided. TI bases its knowledge and belief on information provided by third parties, and makes no representation or warranty as to the accuracy of such information. Efforts are underway to better integrate information from third parties. TI has taken and

continues to take reasonable steps to provide representative and accurate information but may not have conducted destructive testing or chemical analysis on incoming materials and chemicals. TI and TI suppliers consider certain information to be proprietary, and thus CAS numbers and other limited information may not be available for release.

In no event shall TI's liability arising out of such information exceed the total purchase price of the TI part(s) at issue in this document sold by TI to Customer on an annual basis.

TAPE AND REEL INFORMATION

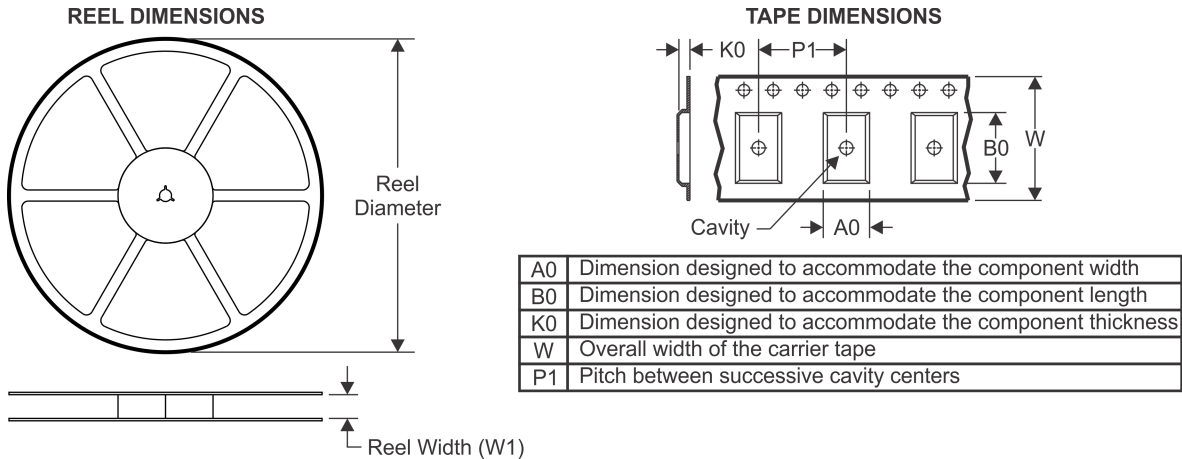

QUADRANT ASSIGNMENTS FOR PIN 1 ORIENTATION IN TAPE



*All dimensions are nominal

Device	Package Type	Package Drawing	Pins	SPQ	Reel Diameter (mm)	Reel Width W1 (mm)	A0 (mm)	B0 (mm)	K0 (mm)	P1 (mm)	W (mm)	Pin1 Quadrant
SN65LVDS1050PWR	TSSOP	PW	16	2000	330.0	12.4	6.9	5.6	1.6	8.0	12.0	Q1

TAPE AND REEL BOX DIMENSIONS



*All dimensions are nominal

Device	Package Type	Package Drawing	Pins	SPQ	Length (mm)	Width (mm)	Height (mm)
SN65LVDS1050PWR	TSSOP	PW	16	2000	367.0	367.0	35.0

PW (R-PDSO-G16)

PLASTIC SMALL OUTLINE

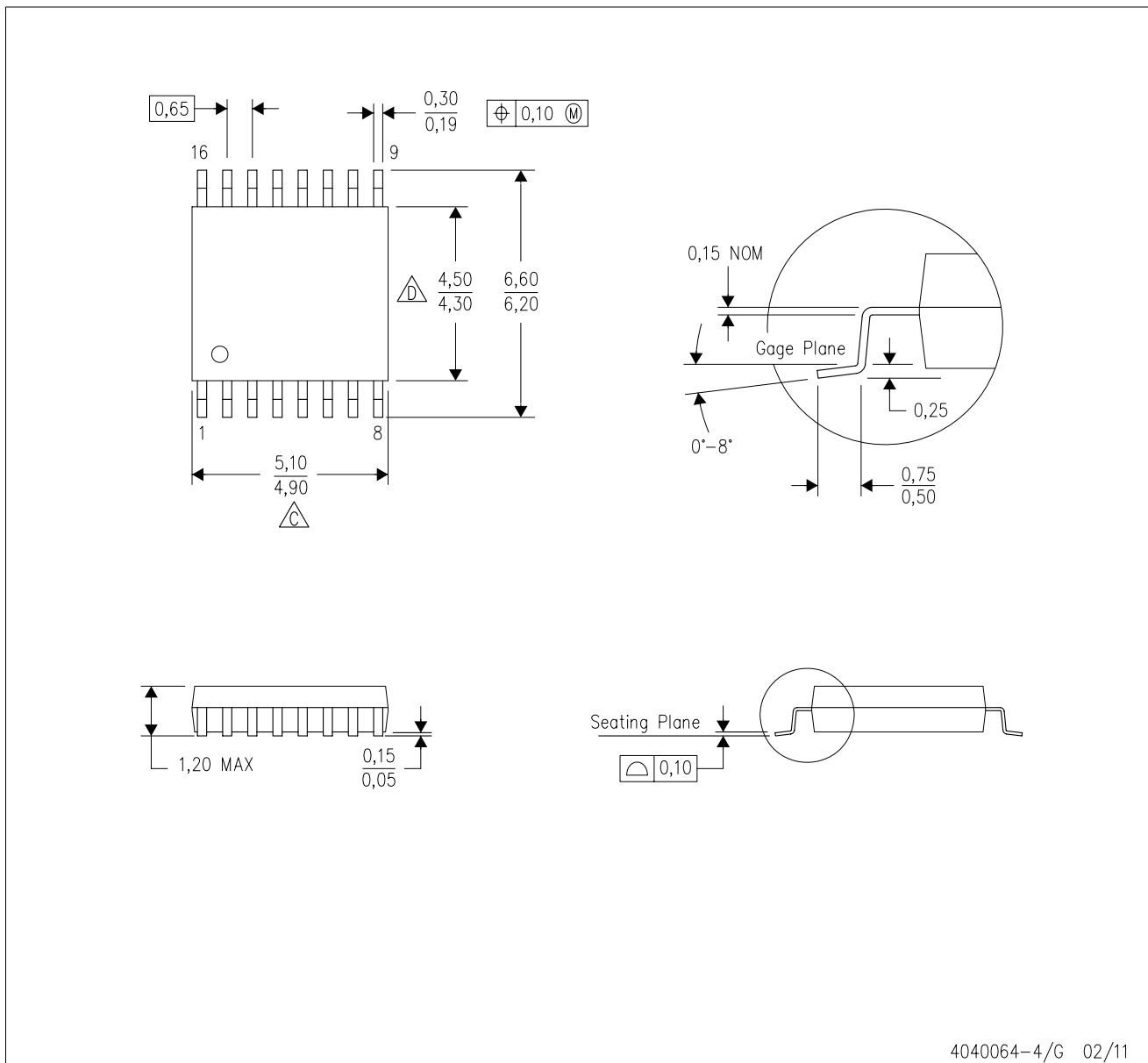

4040064-4/G 02/11

- NOTES:
- A. All linear dimensions are in millimeters. Dimensioning and tolerancing per ASME Y14.5M-1994.
 - B. This drawing is subject to change without notice.
 - C. Body length does not include mold flash, protrusions, or gate burrs. Mold flash, protrusions, or gate burrs shall not exceed 0,15 each side.
 - D. Body width does not include interlead flash. Interlead flash shall not exceed 0,25 each side.
 - E. Falls within JEDEC MO-153

PW (R-PDSO-G16)

PLASTIC SMALL OUTLINE

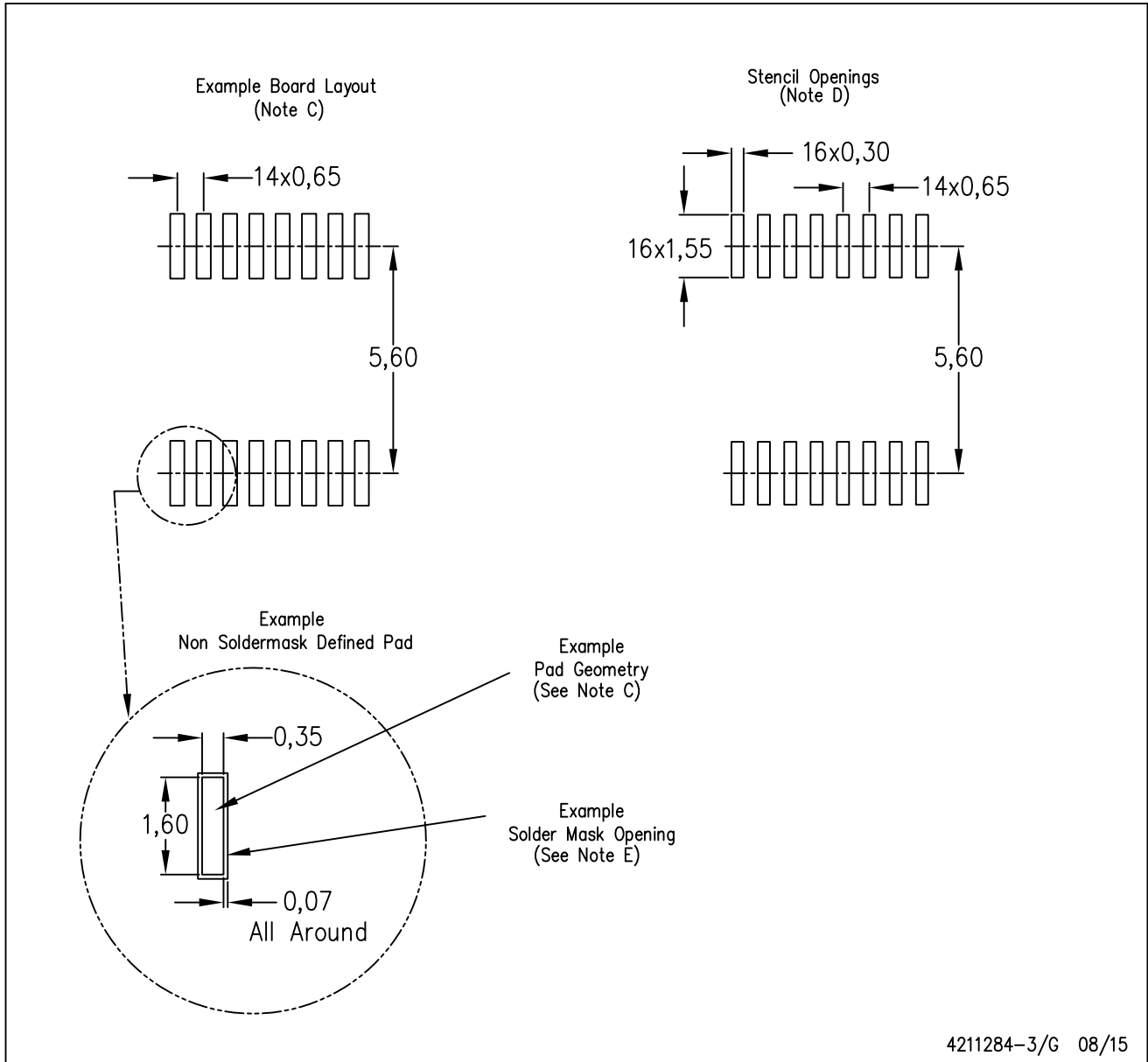

- NOTES:
- All linear dimensions are in millimeters.
 - This drawing is subject to change without notice.
 - Publication IPC-7351 is recommended for alternate designs.
 - Laser cutting apertures with trapezoidal walls and also rounding corners will offer better paste release. Customers should contact their board assembly site for stencil design recommendations. Refer to IPC-7525 for other stencil recommendations.
 - Customers should contact their board fabrication site for solder mask tolerances between and around signal pads.

IMPORTANT NOTICE

Texas Instruments Incorporated and its subsidiaries (TI) reserve the right to make corrections, enhancements, improvements and other changes to its semiconductor products and services per JESD46, latest issue, and to discontinue any product or service per JESD48, latest issue. Buyers should obtain the latest relevant information before placing orders and should verify that such information is current and complete. All semiconductor products (also referred to herein as "components") are sold subject to TI's terms and conditions of sale supplied at the time of order acknowledgment.

TI warrants performance of its components to the specifications applicable at the time of sale, in accordance with the warranty in TI's terms and conditions of sale of semiconductor products. Testing and other quality control techniques are used to the extent TI deems necessary to support this warranty. Except where mandated by applicable law, testing of all parameters of each component is not necessarily performed.

TI assumes no liability for applications assistance or the design of Buyers' products. Buyers are responsible for their products and applications using TI components. To minimize the risks associated with Buyers' products and applications, Buyers should provide adequate design and operating safeguards.

TI does not warrant or represent that any license, either express or implied, is granted under any patent right, copyright, mask work right, or other intellectual property right relating to any combination, machine, or process in which TI components or services are used. Information published by TI regarding third-party products or services does not constitute a license to use such products or services or a warranty or endorsement thereof. Use of such information may require a license from a third party under the patents or other intellectual property of the third party, or a license from TI under the patents or other intellectual property of TI.

Reproduction of significant portions of TI information in TI data books or data sheets is permissible only if reproduction is without alteration and is accompanied by all associated warranties, conditions, limitations, and notices. TI is not responsible or liable for such altered documentation. Information of third parties may be subject to additional restrictions.

Resale of TI components or services with statements different from or beyond the parameters stated by TI for that component or service voids all express and any implied warranties for the associated TI component or service and is an unfair and deceptive business practice. TI is not responsible or liable for any such statements.

Buyer acknowledges and agrees that it is solely responsible for compliance with all legal, regulatory and safety-related requirements concerning its products, and any use of TI components in its applications, notwithstanding any applications-related information or support that may be provided by TI. Buyer represents and agrees that it has all the necessary expertise to create and implement safeguards which anticipate dangerous consequences of failures, monitor failures and their consequences, lessen the likelihood of failures that might cause harm and take appropriate remedial actions. Buyer will fully indemnify TI and its representatives against any damages arising out of the use of any TI components in safety-critical applications.

In some cases, TI components may be promoted specifically to facilitate safety-related applications. With such components, TI's goal is to help enable customers to design and create their own end-product solutions that meet applicable functional safety standards and requirements. Nonetheless, such components are subject to these terms.

No TI components are authorized for use in FDA Class III (or similar life-critical medical equipment) unless authorized officers of the parties have executed a special agreement specifically governing such use.

Only those TI components which TI has specifically designated as military grade or "enhanced plastic" are designed and intended for use in military/aerospace applications or environments. Buyer acknowledges and agrees that any military or aerospace use of TI components which have **not** been so designated is solely at the Buyer's risk, and that Buyer is solely responsible for compliance with all legal and regulatory requirements in connection with such use.

TI has specifically designated certain components as meeting ISO/TS16949 requirements, mainly for automotive use. In any case of use of non-designated products, TI will not be responsible for any failure to meet ISO/TS16949.

Products

Audio	www.ti.com/audio
Amplifiers	amplifier.ti.com
Data Converters	dataconverter.ti.com
DLP® Products	www.dlp.com
DSP	dsp.ti.com
Clocks and Timers	www.ti.com/clocks
Interface	interface.ti.com
Logic	logic.ti.com
Power Mgmt	power.ti.com
Microcontrollers	microcontroller.ti.com
RFID	www.ti-rfid.com
OMAP Applications Processors	www.ti.com/omap
Wireless Connectivity	www.ti.com/wirelessconnectivity

Applications

Automotive and Transportation	www.ti.com/automotive
Communications and Telecom	www.ti.com/communications
Computers and Peripherals	www.ti.com/computers
Consumer Electronics	www.ti.com/consumer-apps
Energy and Lighting	www.ti.com/energy
Industrial	www.ti.com/industrial
Medical	www.ti.com/medical
Security	www.ti.com/security
Space, Avionics and Defense	www.ti.com/space-avionics-defense
Video and Imaging	www.ti.com/video

TI E2E Community

e2e.ti.com