

## 4-PORT LVDS AND 4-PORT TTL-TO-LVDS REPEATERS

### FEATURES

- Receiver and Drivers Meet or Exceed the Requirements of ANSI EIA/TIA-644 Standard
  - SN65LVDS105 Receives Low-Voltage TTL (LVTTTL) Levels
  - SN65LVDS104 Receives Differential Input Levels,  $\pm 100$  mV
- Typical Data Signaling Rates to 400 Mbps or Clock Frequencies to 400 MHz
- Operates From a Single 3.3-V Supply
- Low-Voltage Differential Signaling With Typical Output Voltage of 350 mV and a 100- $\Omega$  Load
- Propagation Delay Time
  - SN65LVDS105 – 2.2 ns (Typ)
  - SN65LVDS104 – 3.1 ns (Typ)
- LVTTTL Levels Are 5-V Tolerant
- Electrically Compatible With LVDS, PECL, LVPECL, LVTTTL, LVCMOS, GTL, BTL, CTT, SSTL, or HSTL Outputs With External Networks
- Driver Outputs Are High Impedance When Disabled or With  $V_{CC} < 1.5$  V
- Bus-Pin ESD Protection Exceeds 16 kV
- SOIC and TSSOP Packaging

### DESCRIPTION

The SN65LVDS104 and SN65LVDS105 are a differential line receiver and a LVTTTL input (respectively) connected to four differential line drivers that implement the electrical characteristics of low-voltage differential signaling (LVDS). LVDS, as specified in EIA/TIA-644 is a data signaling technique that offers low-power, low-noise coupling, and switching speeds to transmit data at relatively long distances. (Note: The ultimate rate and distance of data transfer is dependent upon the attenuation characteristics of the media, the noise coupling to the environment, and other system characteristics.)

The intended application of this device and signaling technique is for point-to-point baseband data transmission over controlled impedance media of approximately 100  $\Omega$ . The transmission media may be printed-circuit board traces, backplanes, or cables. Having the drivers integrated into the same substrate, along with the low pulse skew of balanced signaling, allows extremely precise timing alignment of the signals repeated from the input. This is particularly advantageous in distribution or expansion of signals such as clock or serial data stream.

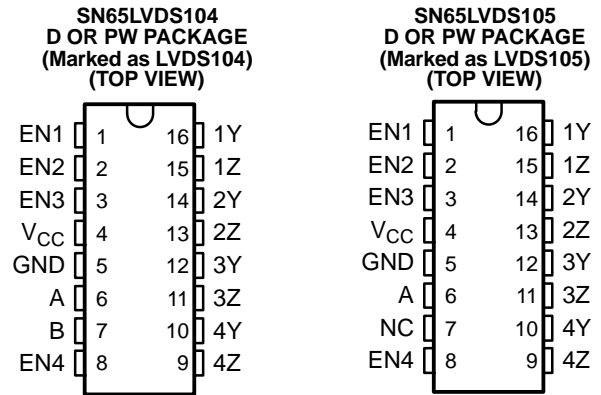

### logic diagram (positive logic)

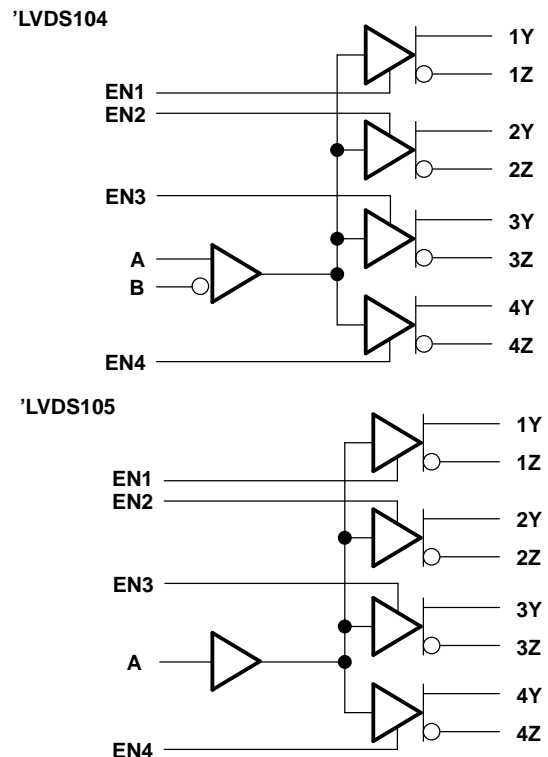

Please be aware that an important notice concerning availability, standard warranty, and use in critical applications of Texas Instruments semiconductor products and disclaimers thereto appears at the end of this data sheet.



These devices have limited built-in ESD protection. The leads should be shorted together or the device placed in conductive foam during storage or handling to prevent electrostatic damage to the MOS gates.

## DESCRIPTION (CONTINUED)

The SN65LVDS104 and SN65LVDS105 are characterized for operation from  $-40^{\circ}\text{C}$  to  $85^{\circ}\text{C}$ .

The SN65LVDS104 and SN65LVDS105 are members of a family of LVDS repeaters. A brief overview of the family is provided in the table below.

### Selection Guide to LVDS Repeaters

DEVICE	NO. INPUTS	NO. OUTPUTS	PACKAGE	COMMENT
SN65LVDS22	2 LVDS	2 LVDS	16-pin D	Dual multiplexed LVDS repeater
SN65LVDS104	1 LVDS	4 LVDS	16-pin D	4-Port LVDS repeater
SN65LVDS105	1 LVTTTL	4 LVDS	16-pin D	4-Port TTL-to-LVDS repeater
SN65LVDS108	1 LVDS	8 LVDS	38-pin DBT	8-Port LVDS repeater
SN65LVDS109	2 LVDS	8 LVDS	38-pin DBT	Dual 4-port LVDS repeater
SN65LVDS116	1 LVDS	16 LVDS	64-pin DGG	16-Port LVDS repeater
SN65LVDS117	2 LVDS	16 LVDS	64-pin DGG	Dual 8-port LVDS repeater

### Function Tables<sup>(1)</sup>

SN65LVDS104				SN65LVDS105			
INPUT		OUTPUT		INPUT		OUTPUT	
$V_{ID} = V_A - V_B$	xEN	xY	xZ	A	ENx	xY	xZ
X	X	Z	Z	L	H	L	H
X	L	Z	Z	H	H	H	L
$V_{ID} \geq 100\text{ mV}$	H	H	L	Open	H	L	H
$-100\text{ mV} < V_{ID} < 100\text{ mV}$	H	?	?	X	L	Z	Z
$V_{ID} \leq -100\text{ mV}$	H	L	H	X	X	Z	Z

(1) H = high level, L = low level, Z = high impedance, ? = indeterminate, X = don't care

## EQUIVALENT INPUT AND OUTPUT SCHEMATIC DIAGRAMS

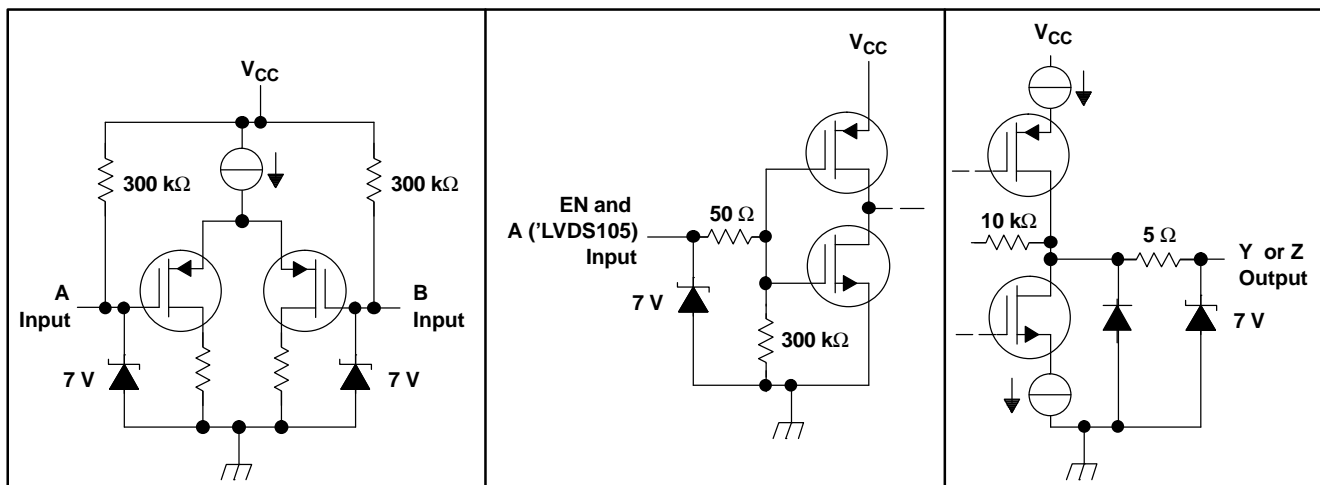

## ABSOLUTE MAXIMUM RATINGS

over operating free-air temperature range (unless otherwise noted) <sup>(1)</sup>

		UNIT
Supply voltage range, $V_{CC}$ <sup>(2)</sup>		–0.5 to 4 V
Voltage range	Enables, A ('LVDS105)	–0.5 to 6 V
	A, B, Y or Z	–0.5 to 4 V
Electrostatic discharge <sup>(3)</sup>	A, B, Y, Z, and GND	Class 3, A:16 kV, B: 400 V
Continuous power dissipation		See Dissipation Rating Table
Storage temperature range		–65°C to 150°C
Lead temperature 1,6 mm (1/16 inch) from case for 10 seconds		260°C

- (1) Stresses beyond those listed under *absolute maximum ratings* may cause permanent damage to the device. These are stress ratings only, and functional operation of the device at these or any other conditions beyond those indicated under *recommended operating conditions* is not implied. Exposure to absolute-maximum-rated conditions for extended periods may affect device reliability.
- (2) All voltage values, except differential I/O bus voltages, are with respect to network ground terminal.
- (3) Tested in accordance with MIL-STD-883C Method 3015.7

## DISSIPATION RATING TABLE

PACKAGE	$T_A \leq 25^\circ\text{C}$ POWER RATING	OPERATING FACTOR <sup>(1)</sup> ABOVE $T_A = 25^\circ\text{C}$	$T_A = 85^\circ\text{C}$ POWER RATING
D	950 mW	7.6 mW/°C	494 mW
PW	774 mW	6.2 mW/°C	402 mW

- (1) This is the inverse of the junction-to-ambient thermal resistance when board-mounted (low-k) and with no air flow.

## RECOMMENDED OPERATING CONDITIONS

		MIN	NOM	MAX	UNIT
$V_{CC}$	Supply voltage	3	3.3	3.6	V
$V_{IH}$	High-level input voltage	2			V
$V_{IL}$	Low-level input voltage			0.8	V
$V_I$ or $V_{IC}$	Voltage at any bus terminal (separately or common-mode)	0		$V_{CC}-0.8$	
$T_A$	Operating free-air temperature	–40		85	°C

## SN65LVDS104 ELECTRICAL CHARACTERISTICS

over recommended operating conditions (unless otherwise noted)

PARAMETER		TEST CONDITIONS	MIN	TYP <sup>(1)</sup>	MAX	UNIT
V <sub>IT+</sub>	Positive-going differential input voltage threshold	See Figure 1 and Table 1			100	mV
V <sub>IT-</sub>	Negative-going differential input voltage threshold		-100			
V <sub>OD</sub>	Differential output voltage magnitude	R <sub>L</sub> = 100 Ω, V <sub>ID</sub> = ± 100 mV, See Figure 1 and Figure 2	247	340	454	mV
Δ V <sub>OD</sub>	Change in differential output voltage magnitude between logic states		-50		50	
V <sub>OC(SS)</sub>	Steady-state common-mode output voltage	See Figure 3	1.125		1.375	V
ΔV <sub>OC(SS)</sub>	Change in steady-state common-mode output voltage between logic states		-50		50	mV
V <sub>OC(PP)</sub>	Peak-to-peak common-mode output voltage			25		150
I <sub>CC</sub>	Supply current	Enabled, R <sub>L</sub> = 100 Ω		23	35	mA
		Disabled		3	8	
I <sub>I</sub>	Input current (A or B inputs)	V <sub>I</sub> = 0 V	-2	-11	-20	μA
		V <sub>I</sub> = 2.4 V	-1.2	-3		
I <sub>I(OFF)</sub>	Power-off Input current	V <sub>CC</sub> = 1.5 V, V <sub>I</sub> = 2.4 V			20	μA
I <sub>IH</sub>	High-level input current (enables)	V <sub>IH</sub> = 2 V			20	μA
I <sub>IL</sub>	Low-level input current (enables)	V <sub>IL</sub> = 0.8 V			10	μA
I <sub>OS</sub>	Short-circuit output current	V <sub>OY</sub> or V <sub>OZ</sub> = 0 V			±10	mA
		V <sub>OD</sub> = 0 V			±10	
I <sub>OZ</sub>	High-impedance output current	V <sub>O</sub> = 0 V or 2.4 V			±1	μA
I <sub>O(OFF)</sub>	Power-off output current	V <sub>CC</sub> = 1.5 V, V <sub>O</sub> = 2.4 V			±1	μA
C <sub>IN</sub>	Input capacitance (A or B inputs)	V <sub>I</sub> = 0.4 sin(4E6πt) + 0.5 V		3		pF
C <sub>O</sub>	Output capacitance (Y or Z outputs)	V <sub>I</sub> = 0.4 sin(4E6πt) + 0.5 V, Disabled		9.4		pF

(1) All typical values are at 25°C and with a 3.3-V supply.

## SN65LVDS104 SWITCHING CHARACTERISTICS

over recommended operating conditions (unless otherwise noted)

PARAMETER		TEST CONDITIONS	MIN	TYP <sup>(1)</sup>	MAX	UNIT
t <sub>PLH</sub>	Propagation delay time, low-to-high-level output	R <sub>L</sub> = 100 Ω, C <sub>L</sub> = 10 pF, See Figure 4	2.4	3.2	4.2	ns
t <sub>PHL</sub>	Propagation delay time, high-to-low-level output		2.2	3.1	4.2	ns
t <sub>r</sub>	Differential output signal rise time		0.3	0.8	1.2	ns
t <sub>f</sub>	Differential output signal fall time		0.3	0.8	1.2	ns
t <sub>sk(p)</sub>	Pulse skew ( t <sub>PHL</sub> - t <sub>PLH</sub>  )			150	500	ps
t <sub>sk(o)</sub>	Channel-to-channel output skew <sup>(2)</sup>			20	100	ps
t <sub>sk(pp)</sub>	Part-to-part skew <sup>(3)</sup>			1.5	ns	
t <sub>pZH</sub>	Propagation delay time, high-impedance-to-high-level output	See Figure 5		7.2	15	ns
t <sub>pZL</sub>	Propagation delay time, high-impedance-to-low-level output			8.4	15	ns
t <sub>pHZ</sub>	Propagation delay time, high-level-to-high-impedance output			3.6	15	ns
t <sub>pLZ</sub>	Propagation delay time, low-level-to-high-impedance output			6	15	ns

(1) All typical values are at 25°C and with a 3.3-V supply.

(2) t<sub>sk(o)</sub> is the magnitude of the time difference between the t<sub>PLH</sub> or t<sub>PHL</sub> of all drivers of a single device with all of their inputs connected together.

(3) t<sub>sk(pp)</sub> is the magnitude of the difference in propagation delay times between any specified terminals of two devices when both devices operate with the same supply voltages, at the same temperature, and have identical packages and test circuits.

## SN65LVDS105 ELECTRICAL CHARACTERISTICS

over recommended operating conditions (unless otherwise noted)

PARAMETER		TEST CONDITIONS	MIN	TYP <sup>(1)</sup>	MAX	UNIT
$ V_{OD} $	Differential output voltage magnitude	$R_L = 100 \Omega$ , $V_{ID} = \pm 100 \text{ mV}$ , See Figure 6 and Figure 7	247	340	454	mV
$\Delta V_{OD} $	Change in differential output voltage magnitude between logic states		-50		50	
$V_{OC(SS)}$	Steady-state common-mode output voltage	See Figure 8	1.125		1.375	V
$\Delta V_{OC(SS)}$	Change in steady-state common-mode output voltage between logic states		-50		50	mV
$V_{OC(PP)}$	Peak-to-peak common-mode output voltage			25	150	mV
$I_{CC}$	Supply current	Enabled, $R_L = 100 \Omega$		23	35	mA
		Disabled		0.7	6.4	mA
$I_{IH}$	High-level input current	$V_{IH} = 2 \text{ V}$			20	$\mu\text{A}$
$I_{IL}$	Low-level input current	$V_{IL} = 0.8 \text{ V}$			10	$\mu\text{A}$
$I_{OS}$	Short-circuit output current	$V_{OY}$ or $V_{OZ} = 0 \text{ V}$			$\pm 10$	mA
		$V_{OD} = 0 \text{ V}$			$\pm 10$	mA
$I_{OZ}$	High-impedance output current	$V_O = 0 \text{ V}$ or $2.4 \text{ V}$			$\pm 1$	$\mu\text{A}$
$I_{O(OFF)}$	Power-off output current	$V_{CC} = 1.5 \text{ V}$ , $V_O = 2.4 \text{ V}$		0.3	$\pm 1$	$\mu\text{A}$
$C_{IN}$	Input capacitance	$V_I = 0.4 \sin(4E6\pi t) + 0.5 \text{ V}$		5		pF
$C_O$	Output capacitance (Y or Z outputs)	$V_I = 0.4 \sin(4E6\pi t) + 0.5 \text{ V}$ , Disabled		9.4		pF

(1) All typical values are at 25°C and with a 3.3-V supply.

## SN65LVDS105 SWITCHING CHARACTERISTICS

over recommended operating conditions (unless otherwise noted)

PARAMETER		TEST CONDITIONS	MIN	TYP <sup>(1)</sup>	MAX	UNIT
$t_{PLH}$	Propagation delay time, low-to-high-level output	$R_L = 100 \Omega$ , $C_L = 10 \text{ pF}$ , See Figure 9	1.7	2.2	3	ns
$t_{PHL}$	Propagation delay time, high-to-low-level output		1.4	2.3	3.5	ns
$t_r$	Differential output signal rise time		0.3	0.8	1.2	ns
$t_f$	Differential output signal fall time		0.3	0.8	1.2	ns
$t_{sk(p)}$	Pulse skew ( $ t_{PHL} - t_{PLH} $ )			150	500	ps
$t_{sk(o)}$	Channel-to-channel output skew <sup>(2)</sup>			20	100	ps
$t_{sk(pp)}$	Part-to-part skew <sup>(3)</sup>			1.5	ns	
$t_{PZH}$	Propagation delay time, high-impedance-to-high-level output	See Figure 10		7.2	15	ns
$t_{PZL}$	Propagation delay time, high-impedance-to-low-level output			8.4	15	ns
$t_{PHZ}$	Propagation delay time, high-level-to-high-impedance output			3.6	15	ns
$t_{PLZ}$	Propagation delay time, low-level-to-high-impedance output			6	15	ns

(1) All typical values are at 25°C and with a 3.3-V supply.

(2)  $t_{sk(o)}$  is the magnitude of the time difference between the  $t_{PLH}$  or  $t_{PHL}$  of all drivers of a single device with all of their inputs connected together.

(3)  $t_{sk(pp)}$  is the magnitude of the difference in propagation delay times between any specified terminals of two devices when both devices operate with the same supply voltages, at the same temperature, and have identical packages and test circuits.

PARAMETER MEASUREMENT INFORMATION

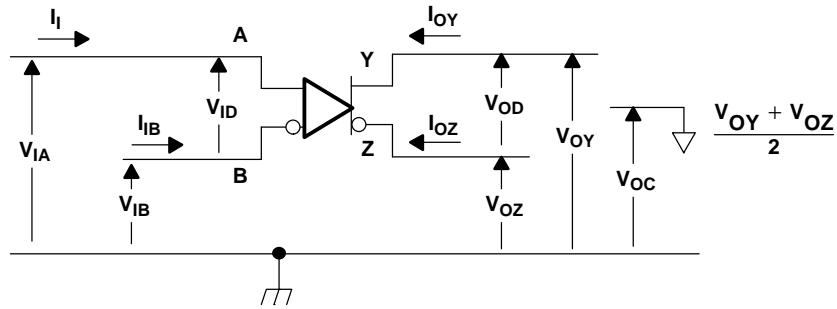

Figure 1. 'LVDS104 Voltage and Current Definitions

Table 1. SN65LVDS104 Minimum and Maximum Input Threshold Test Voltages

APPLIED VOLTAGES		RESULTING DIFFERENTIAL INPUT VOLTAGE	RESULTING COMMON-MODE INPUT VOLTAGE
$V_{IA}$	$V_{IB}$	$V_{ID}$	$V_{IC}$
1.25 V	1.15 V	100 mV	1.2 V
1.15 V	1.25 V	-100 mV	1.2 V
2.4 V	2.3 V	100 mV	2.35 V
2.3 V	2.4 V	-100 mV	2.35 V
0.1 V	0 V	100 mV	0.05 V
0 V	0.1 V	-100 mV	0.05 V
1.5 V	0.9 V	600 mV	1.2 V
0.9 V	1.5 V	-600 mV	1.2 V
2.4 V	1.8 V	600 mV	2.1 V
1.8 V	2.4 V	-600 mV	2.1 V
0.6 V	0 V	600 mV	0.3 V
0 V	0.6 V	-600 mV	0.3 V

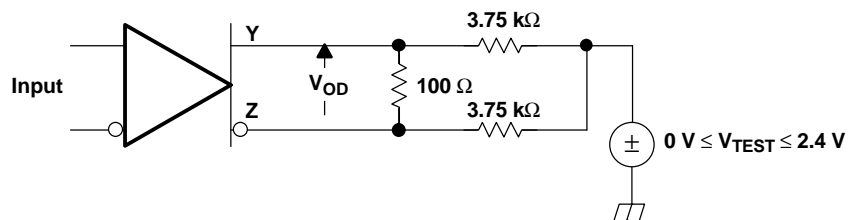
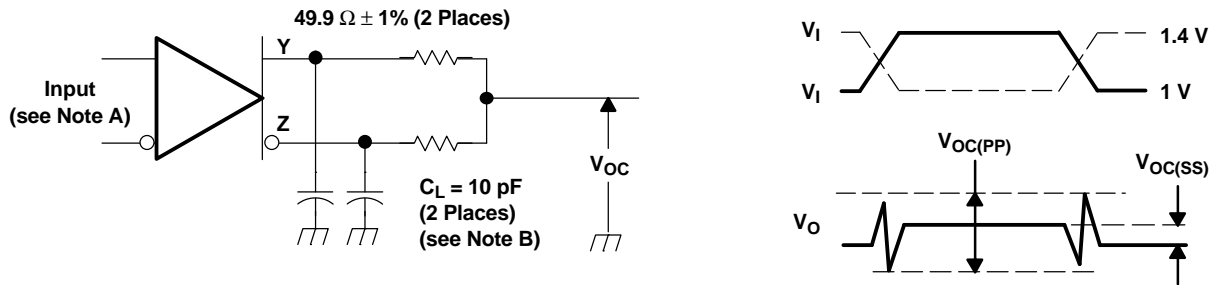
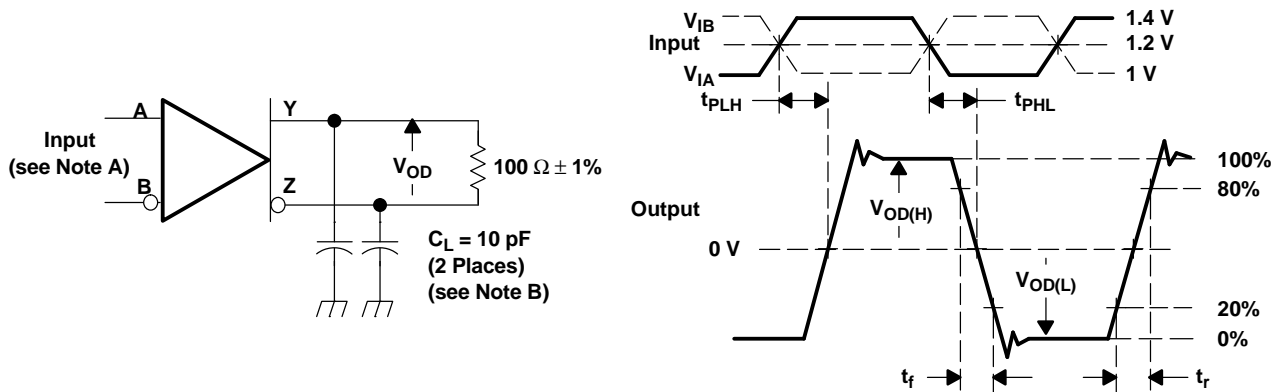

Figure 2. 'LVDS104  $V_{OD}$  Test Circuit



- A. All input pulses are supplied by a generator having the following characteristics:  $t_r$  or  $t_f \leq 1$  ns, pulse repetition rate (PRR) = 0.5 Mpps, pulsewidth =  $500 \pm 10$  ns.
- B.  $C_L$  includes instrumentation and fixture capacitance within 0,06 m of the D.U.T. The measurement of  $V_{OC(PP)}$  is made on test equipment with a  $-3$  dB bandwidth of at least 300 MHz.

Figure 3. 'LVDS104 Test Circuit and Definitions for the Driver Common-Mode Output Voltage



- A. All input pulses are supplied by a generator having the following characteristics:  $t_r$  or  $t_f \leq 1$  ns, pulse repetition rate (PRR) = 50 Mpps, pulsewidth =  $10 \pm 0.2$  ns.
- B.  $C_L$  includes instrumentation and fixture capacitance within 0,06 m of the D.U.T.

Figure 4. 'LVDS104 Test Circuit, Timing, and Voltage Definitions for the Differential Output Signal

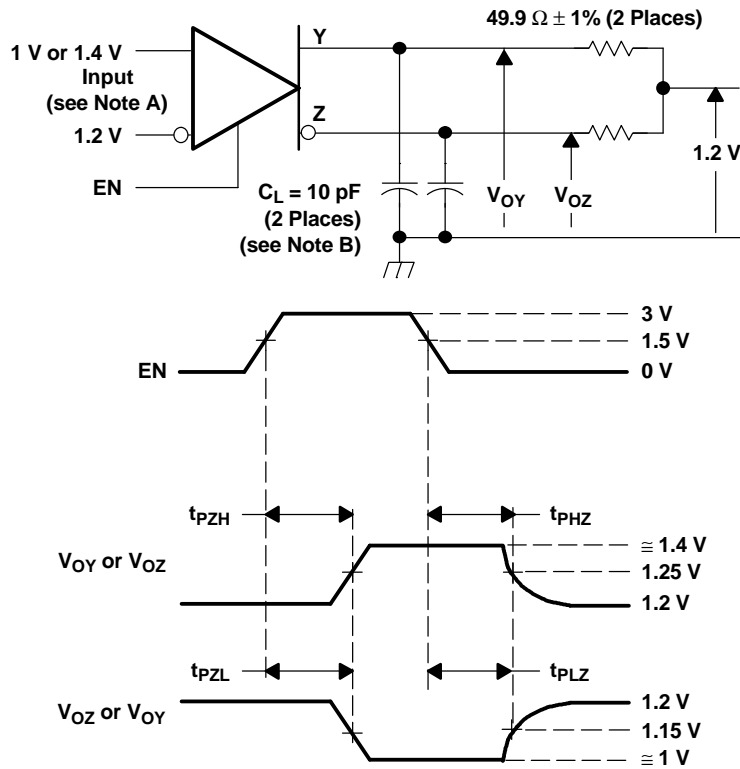

- A. All input pulses are supplied by a generator having the following characteristics:  $t_r$  or  $t_f \leq 1$  ns, pulse repetition rate (PRR) = 0.5 Mpps, pulsewidth =  $500 \pm 10$  ns.
- B.  $C_L$  includes instrumentation and fixture capacitance within 0,06 m of the D.U.T.

Figure 5. 'LVDS104 Enable and Disable Time Circuit and Definitions

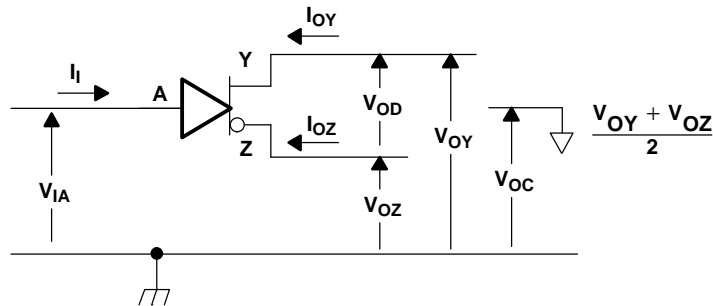

Figure 6. 'LVDS105 Voltage and Current Definitions

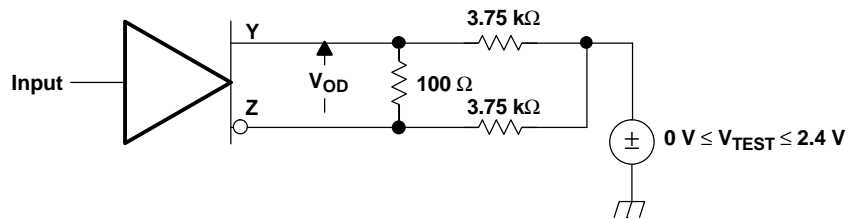
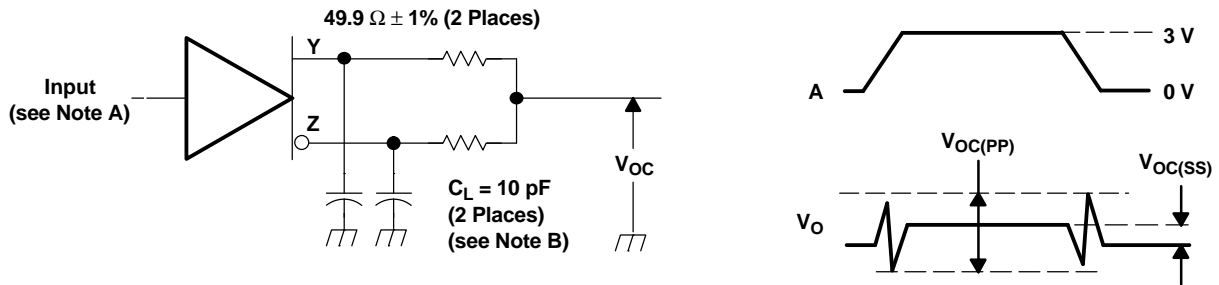
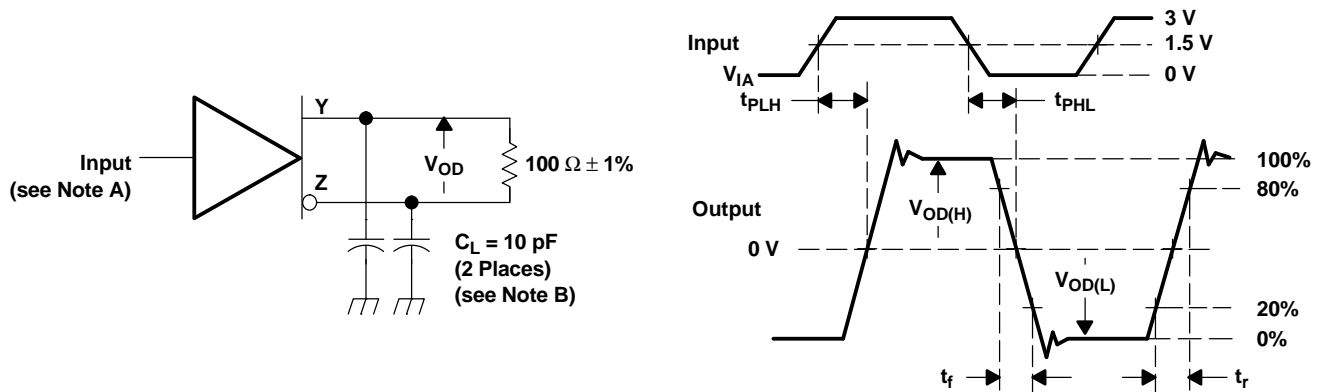

Figure 7. 'LVDS105 VOD Test Circuit



- A. All input pulses are supplied by a generator having the following characteristics:  $t_r$  or  $t_f \leq 1$  ns, pulse repetition rate (PRR) = 0.5 Mpps, pulsewidth =  $500 \pm 10$  ns.
- B.  $C_L$  includes instrumentation and fixture capacitance within 0,06 m of the D.U.T. The measurement of  $V_{OC(PP)}$  is made on test equipment with a -3 dB bandwidth of at least 300 MHz.

**Figure 8. 'LVDS105 Test Circuit and Definitions for the Driver Common-Mode Output Voltage**



- A. All input pulses are supplied by a generator having the following characteristics:  $t_r$  or  $t_f \leq 1$  ns, pulse repetition rate (PRR) = 50 Mpps, pulsewidth =  $10 \pm 0.2$  ns.
- B.  $C_L$  includes instrumentation and fixture capacitance within 0,06 m of the D.U.T.

**Figure 9. 'LVDS105 Test Circuit, Timing, and Voltage Definitions for the Differential Output Signal**

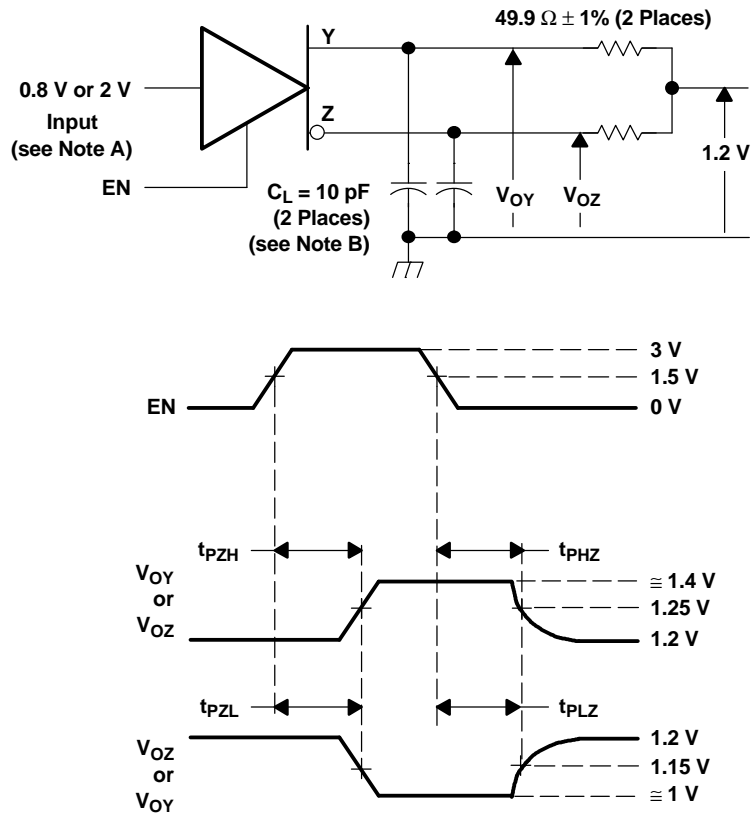

- A. All input pulses are supplied by a generator having the following characteristics:  $t_r$  or  $t_f \leq 1$  ns, pulse repetition rate (PRR) = 0.5 Mpps, pulsewidth =  $500 \pm 10$  ns.
- B.  $C_L$  includes instrumentation and fixture capacitance within 0,06 m of the D.U.T.

**Figure 10. 'LVDS105 Enable and Disable Time Circuit and Definitions**

**TYPICAL CHARACTERISTIC**

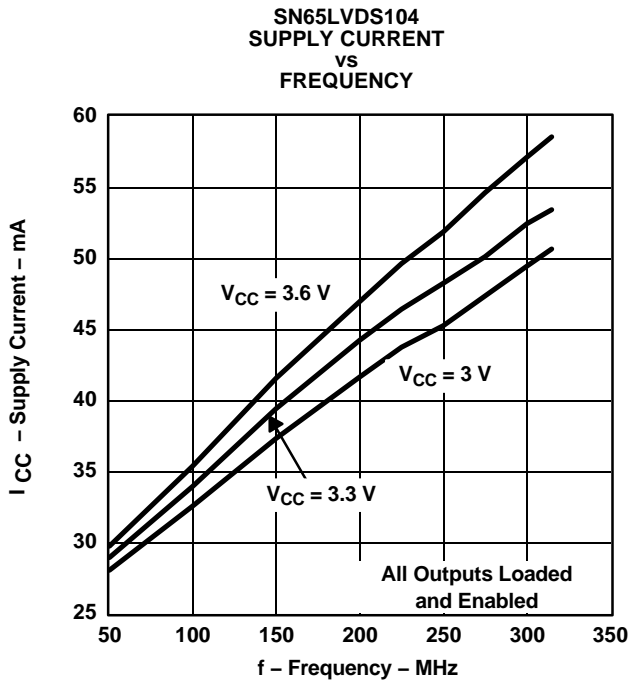

Figure 11.

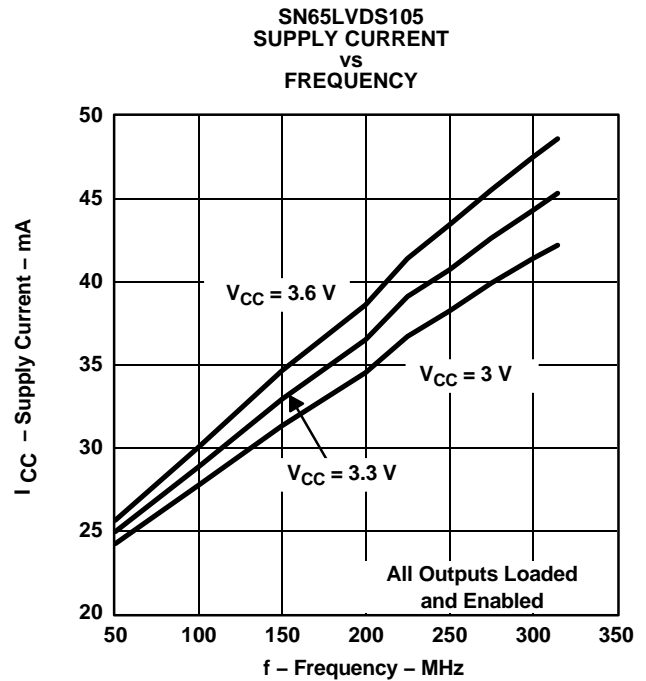

Figure 12.

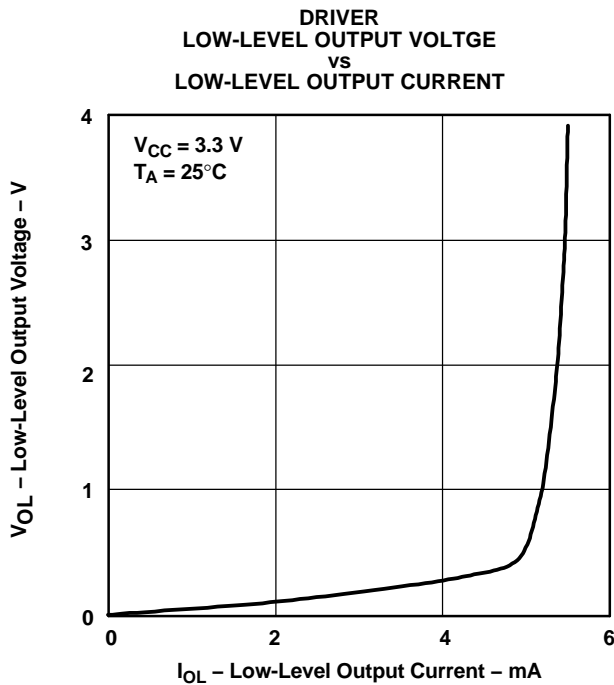

Figure 13.

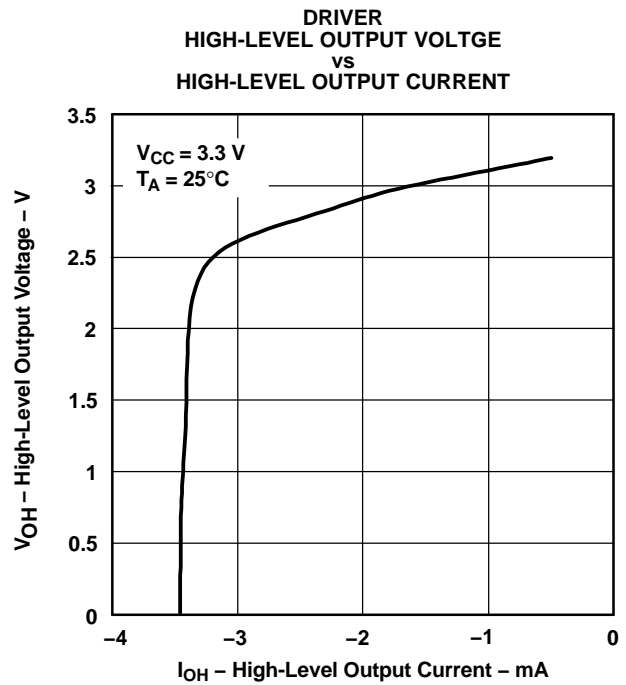

Figure 14.

TYPICAL CHARACTERISTIC (continued)

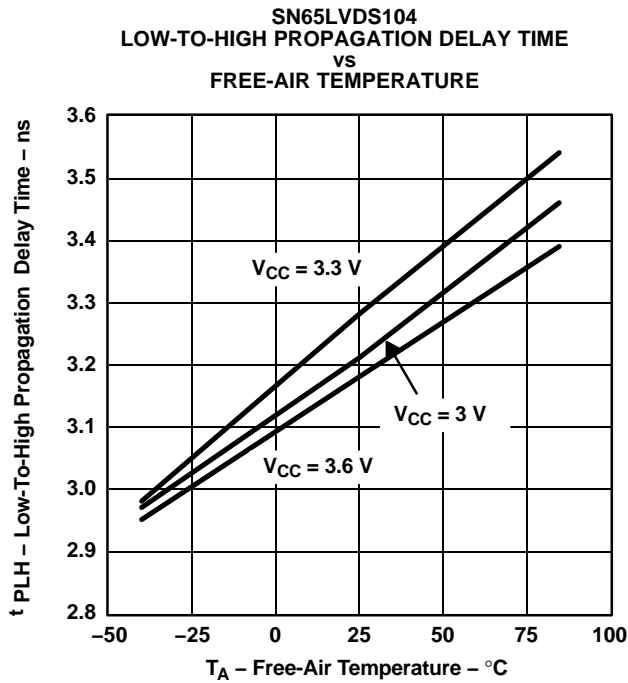

Figure 15.

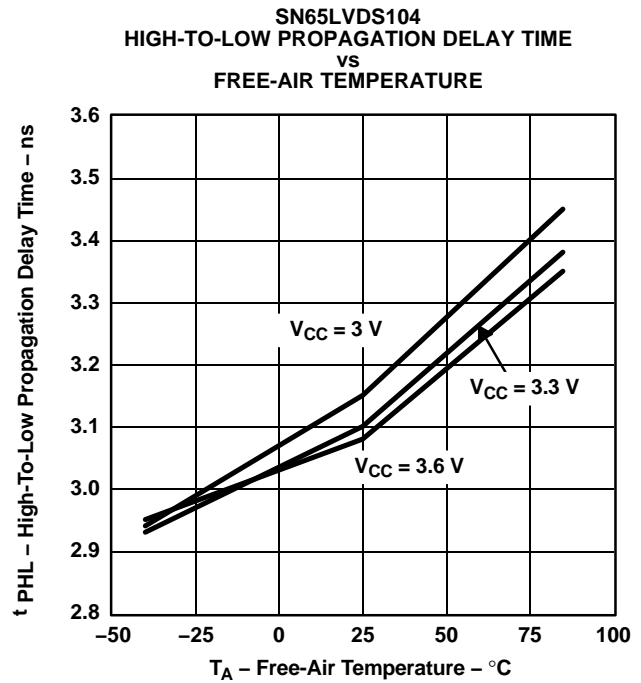

Figure 16.

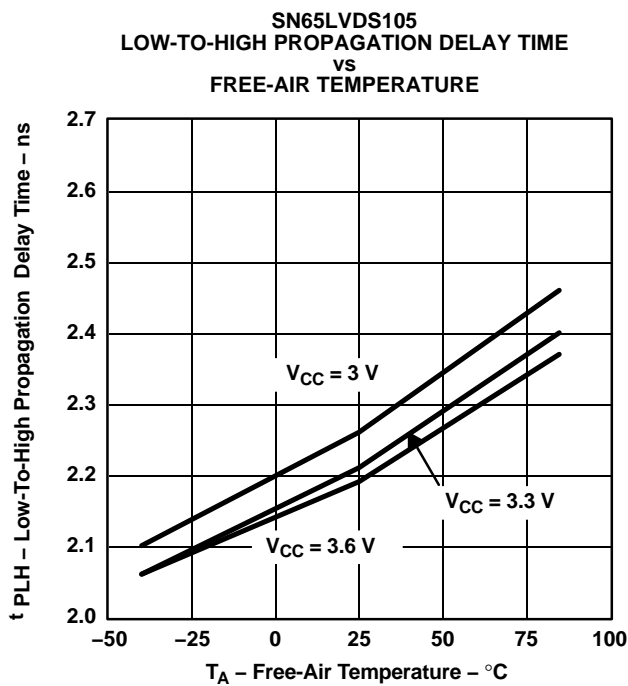

Figure 17.

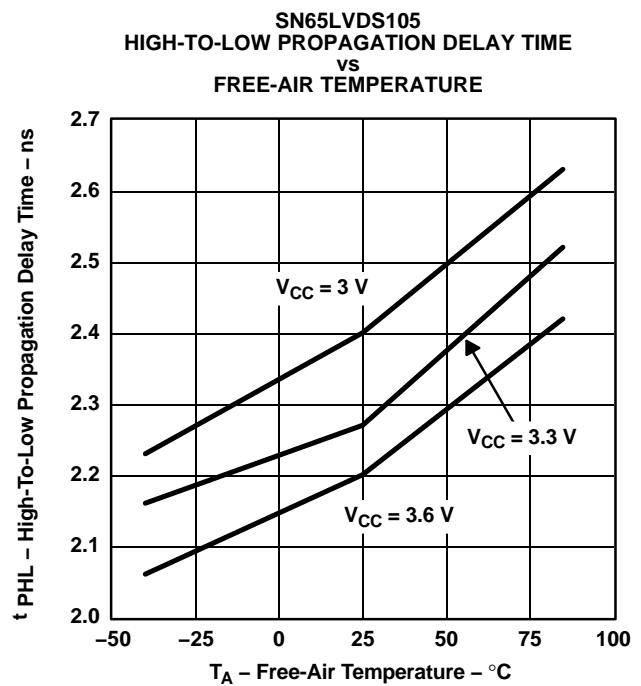
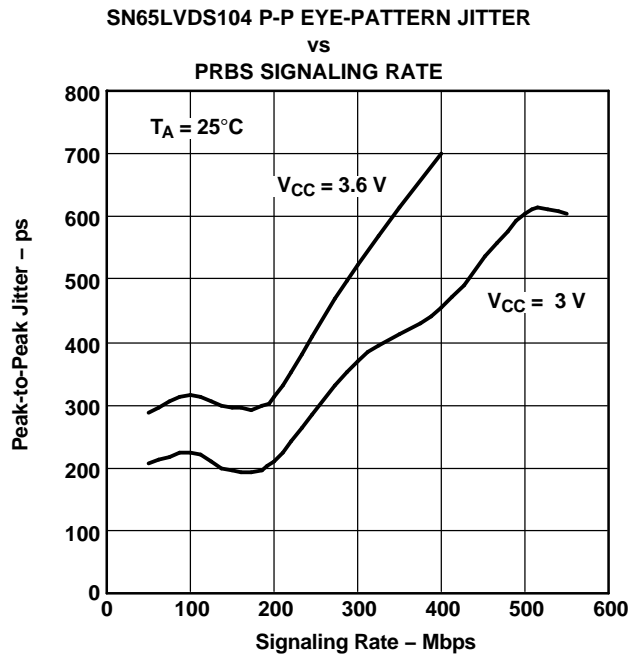

Figure 18.

TYPICAL CHARACTERISTIC (continued)



NOTES: Input: 2<sup>15</sup> PRBS with peak-to-peak jitter <115 ps at 100 Mbps. Test board adds about 70 ps p-p jitter. All outputs enabled and loaded with differential 100-Ω loads, worst-case output, supply decoupled with 0.1-μF ceramic 0603-style capacitors 1 cm from the device.

Figure 19.

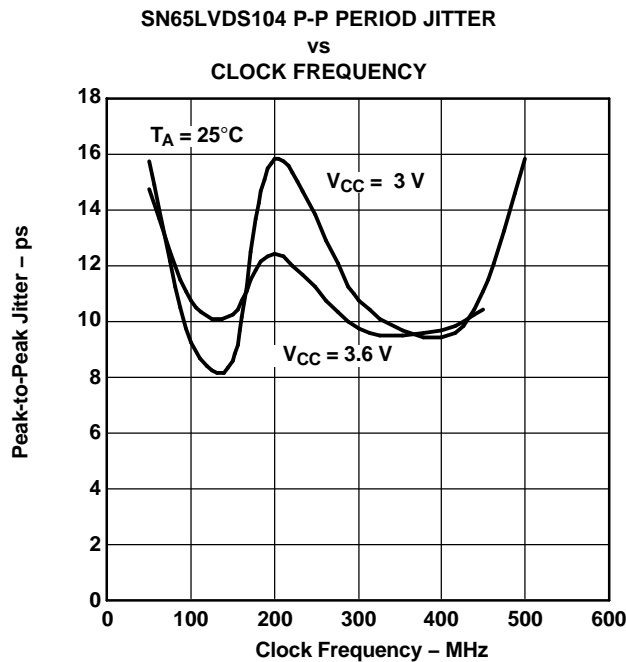

NOTES: Input: 50% duty cycle square wave with period jitter < 9 ps at 100 MHz. Test board adds about 5 ps p-p jitter. All outputs enabled and loaded with differential 100-Ω loads, worst-case output, supply decoupled with 0.1-μF and 0.001-μF ceramic 0603-style capacitors 1 cm from the device.

Figure 20.

TYPICAL CHARACTERISTIC (continued)

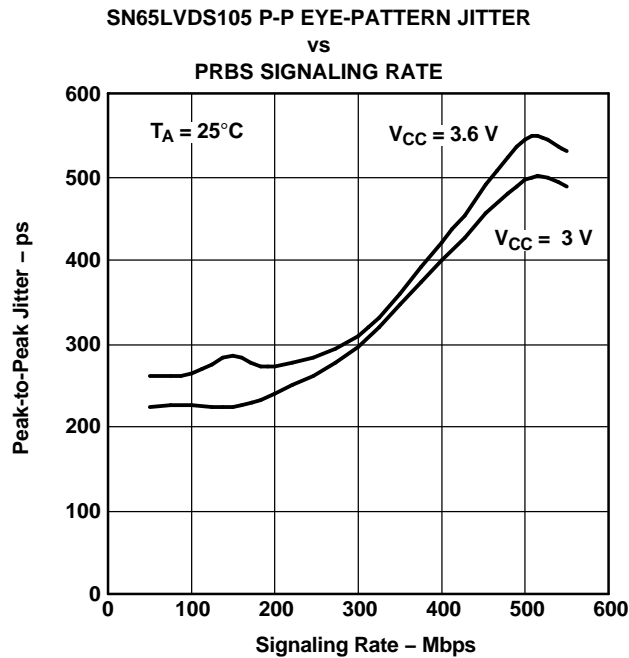

NOTES: Input:  $2^{15}$  PRBS with peak-to-peak Jitter < 147 ps at 100 Mbps, Test board adds about 43 ps p-p jitter. All outputs enabled and loaded with differential 100-Ω loads, worst-case output, supply decoupled with 0.1-μF and 0.001-μF ceramic 0603-style capacitors 1 cm from the device.

Figure 21.

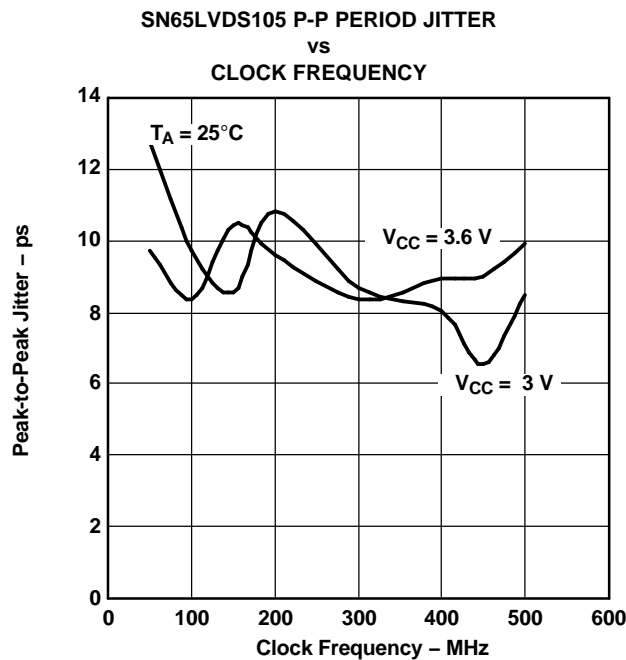

NOTES: Input: 50% duty cycle square wave with period jitter < 10 ps at 100 MHz. Test board adds about 5 ps p-p jitter. All outputs enabled and loaded with differential 100-Ω loads, worst-case output, supply decoupled with 0.1-μF and 0.001-μF ceramic 0603-style capacitors 1 cm from the device.

Figure 22.

## APPLICATION INFORMATION

### INPUT LEVEL TRANSLATION

An LVDS receiver can be used to receive various other types of logic signals. Figure 23 through Figure 32 show the termination circuits for SSTL, HSTL, GTL, BTL, LVPECL, PECL, CMOS, and TTL.

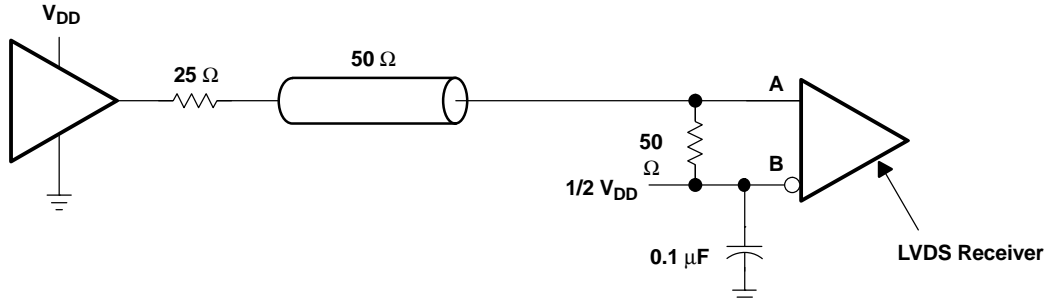

Figure 23. Stub-Series Terminated (SSTL) or High-Speed Transceiver Logic (HSTL)

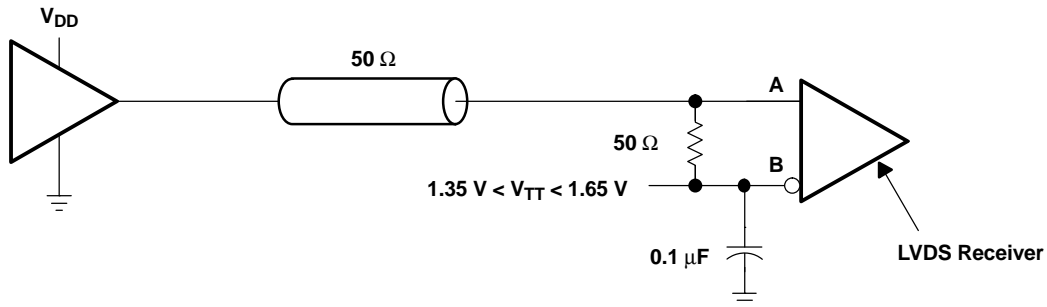

Figure 24. Center-Tap Termination (CTT)

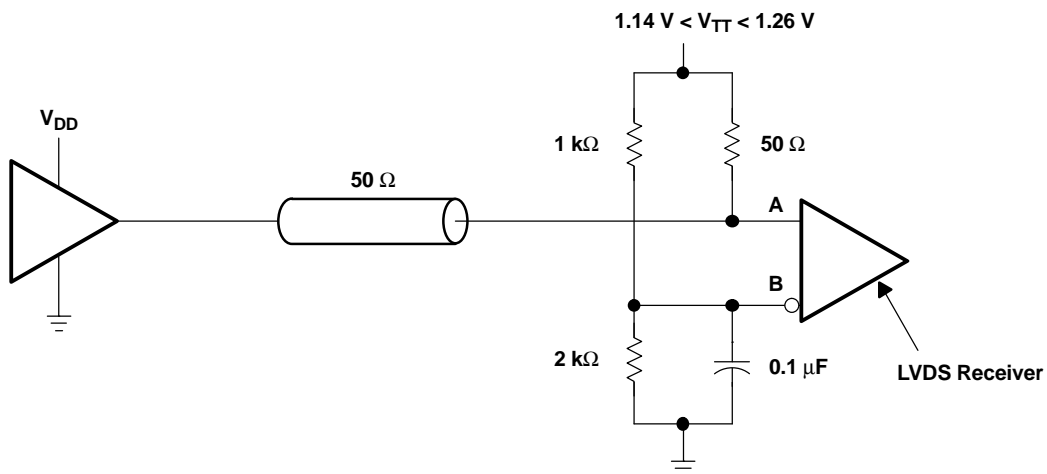

Figure 25. Gunning Transceiver Logic (GTL)

APPLICATION INFORMATION (continued)

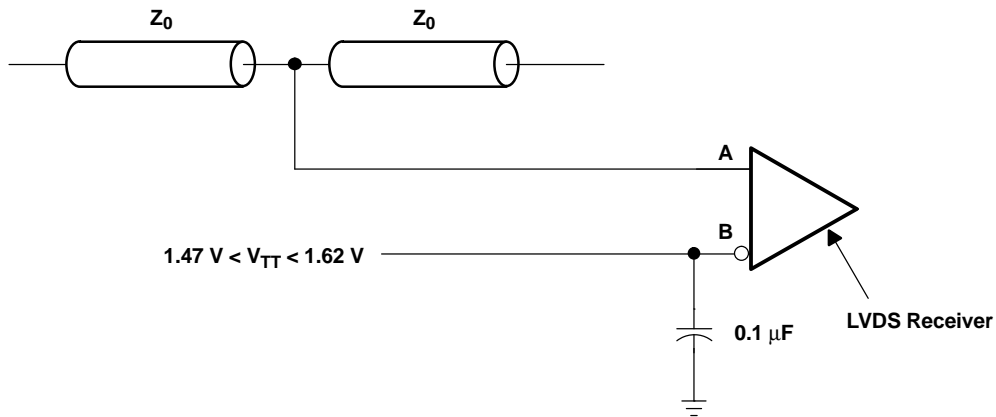

Figure 26. Backplane Transceiver Logic (BTL)

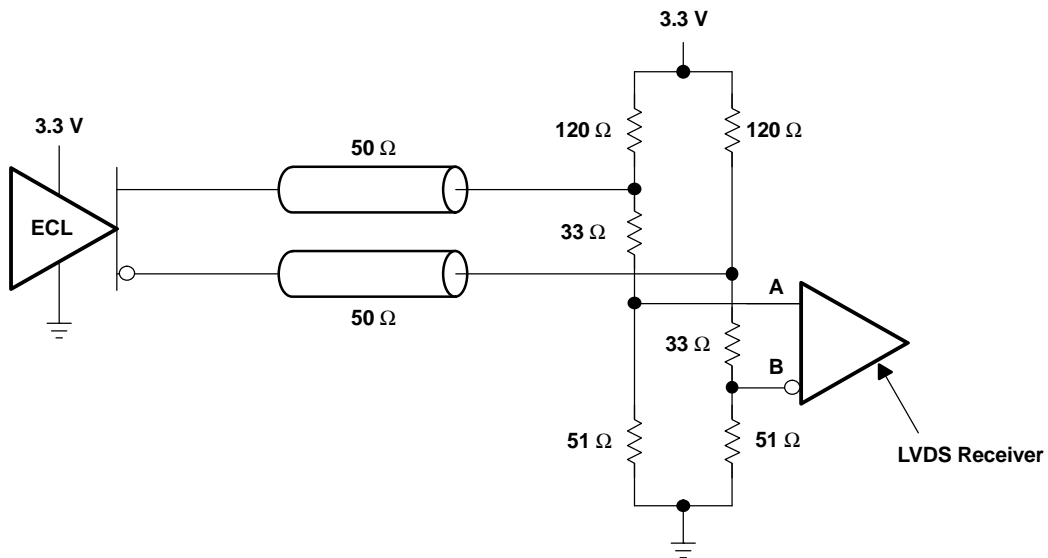
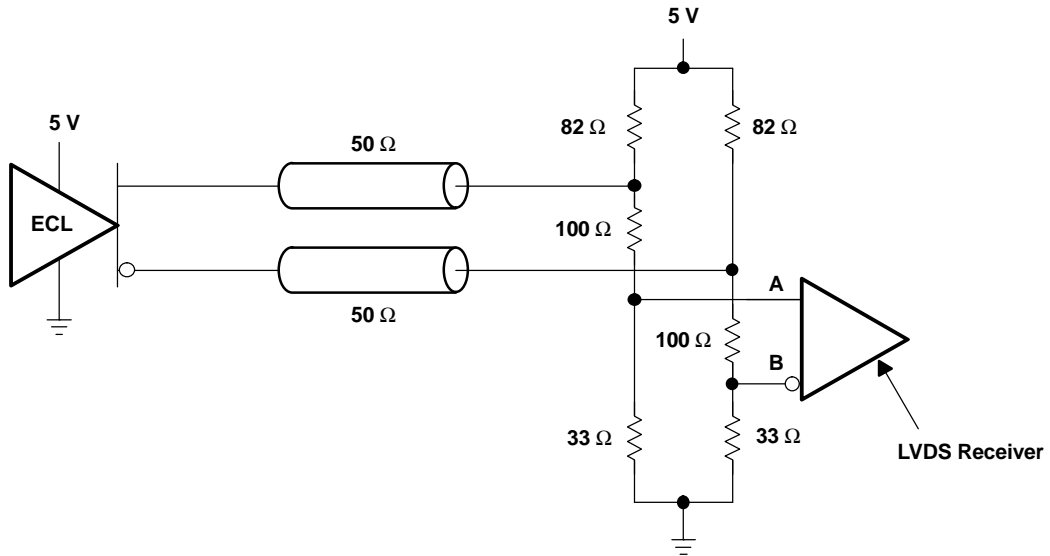
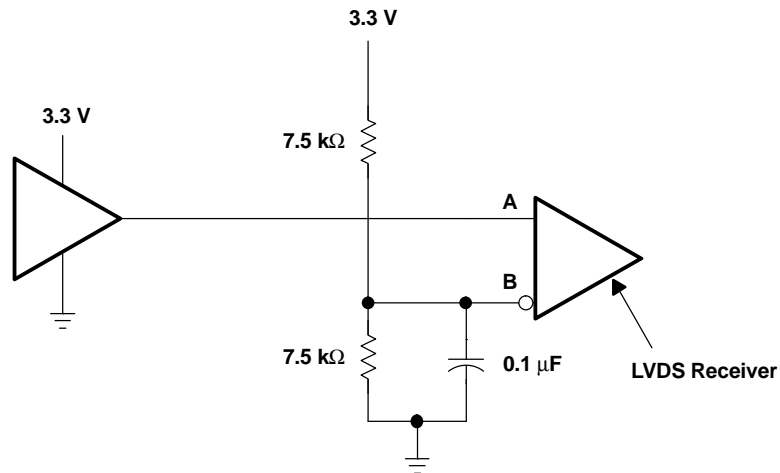

Figure 27. Low-Voltage Positive Emitter-Coupled Logic (LVPECL)

**APPLICATION INFORMATION (continued)**



**Figure 28. Positive Emitter-Coupled Logic (PECL)**



**Figure 29. 3.3-V CMOS**

APPLICATION INFORMATION (continued)

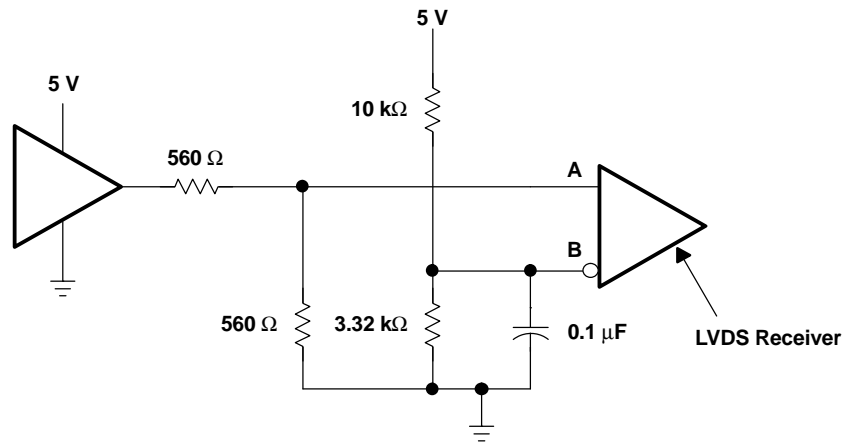

Figure 30. 5-V CMOS

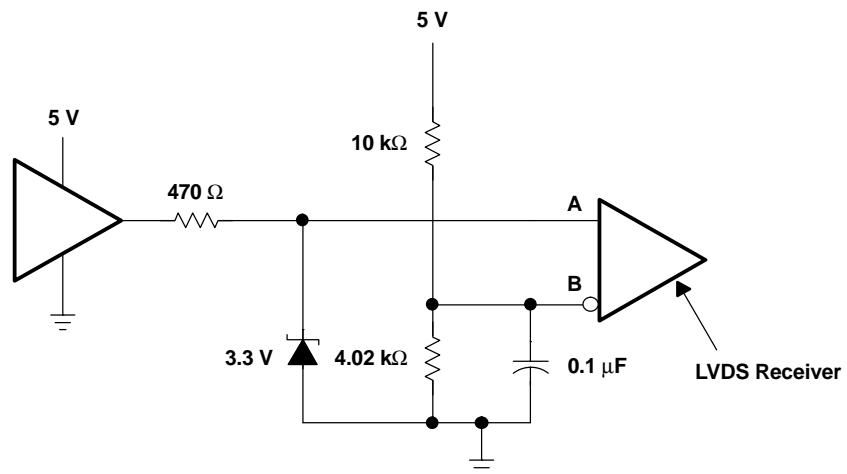

Figure 31. 5-V TTL

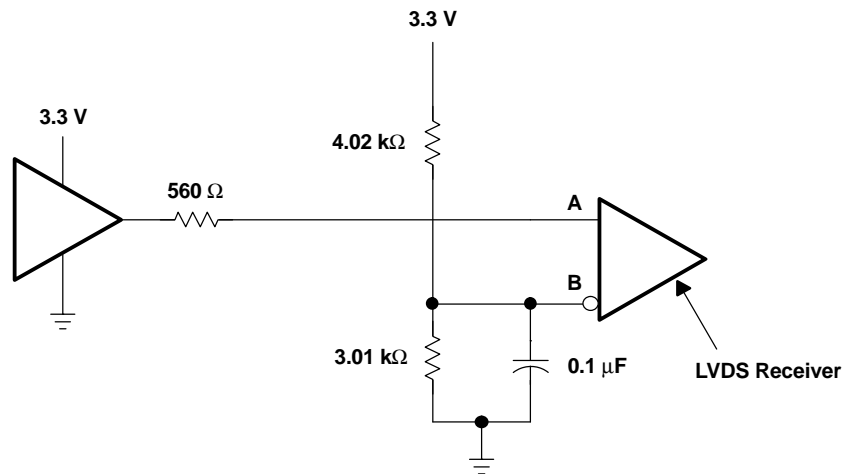

Figure 32. LVTTTL

## APPLICATION INFORMATION (continued)

### FAIL SAFE

A common problem with differential signaling applications is how the system responds when no differential voltage is present on the signal pair. The LVDS receiver is like most differential line receivers, in that its output logic state can be indeterminate when the differential input voltage is between  $-100\text{ mV}$  and  $100\text{ mV}$  and within its recommended input common-mode voltage range. However, TI LVDS receivers handles the open-input circuit situation differently.

Open-circuit means that there is little or no input current to the receiver from the data line itself. This could be when the driver is in a high-impedance state or the cable is disconnected. When this occurs, the LVDS receiver pulls each line of the signal pair to near  $V_{CC}$  through  $300\text{-k}\Omega$  resistors as shown in Figure 33. The fail-safe feature uses an AND gate with input voltage thresholds at about  $2.3\text{ V}$  to detect this condition and force the output to a high-level regardless of the differential input voltage.

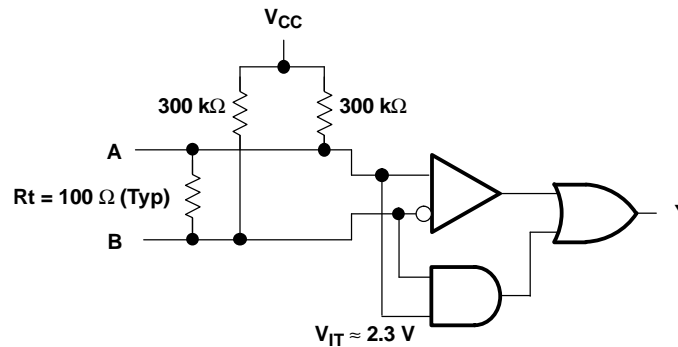

**Figure 33. Open-Circuit Fail Safe of the LVDS Receiver**

It is only under these conditions that the output of the receiver will be valid with less than a  $100\text{ mV}$  differential input voltage magnitude. The presence of the termination resistor,  $R_t$ , does not affect the fail-safe function as long as it is connected as shown in Figure 33. Other termination circuits may allow a dc current to ground that could defeat the pullup currents from the receiver and the fail-safe feature.

**PACKAGING INFORMATION**

Orderable Device	Status (1)	Package Type	Package Drawing	Pins	Package Qty	Eco Plan (2)	Lead/Ball Finish (6)	MSL Peak Temp (3)	Op Temp (°C)	Device Marking (4/5)	Samples
SN65LVDS104D	ACTIVE	SOIC	D	16	40	Green (RoHS & no Sb/Br)	CU NIPDAU	Level-1-260C-UNLIM	-40 to 85	LVDS104	<a href="#">Samples</a>
SN65LVDS104DG4	ACTIVE	SOIC	D	16	40	Green (RoHS & no Sb/Br)	CU NIPDAU	Level-1-260C-UNLIM	-40 to 85	LVDS104	<a href="#">Samples</a>
SN65LVDS104DR	ACTIVE	SOIC	D	16	2500	Green (RoHS & no Sb/Br)	CU NIPDAU	Level-1-260C-UNLIM	-40 to 85	LVDS104	<a href="#">Samples</a>
SN65LVDS104DRG4	ACTIVE	SOIC	D	16	2500	Green (RoHS & no Sb/Br)	CU NIPDAU	Level-1-260C-UNLIM	-40 to 85	LVDS104	<a href="#">Samples</a>
SN65LVDS104PW	ACTIVE	TSSOP	PW	16	90	Green (RoHS & no Sb/Br)	CU NIPDAU	Level-1-260C-UNLIM	-40 to 85	LVDS104	<a href="#">Samples</a>
SN65LVDS104PWG4	ACTIVE	TSSOP	PW	16	90	Green (RoHS & no Sb/Br)	CU NIPDAU	Level-1-260C-UNLIM	-40 to 85	LVDS104	<a href="#">Samples</a>
SN65LVDS104PWR	ACTIVE	TSSOP	PW	16	2000	Green (RoHS & no Sb/Br)	CU NIPDAU	Level-1-260C-UNLIM	-40 to 85	LVDS104	<a href="#">Samples</a>
SN65LVDS104PWRG4	ACTIVE	TSSOP	PW	16	2000	Green (RoHS & no Sb/Br)	CU NIPDAU	Level-1-260C-UNLIM	-40 to 85	LVDS104	<a href="#">Samples</a>
SN65LVDS105D	ACTIVE	SOIC	D	16	40	Green (RoHS & no Sb/Br)	CU NIPDAU	Level-1-260C-UNLIM	-40 to 85	LVDS105	<a href="#">Samples</a>
SN65LVDS105DG4	ACTIVE	SOIC	D	16	40	Green (RoHS & no Sb/Br)	CU NIPDAU	Level-1-260C-UNLIM	-40 to 85	LVDS105	<a href="#">Samples</a>
SN65LVDS105DR	ACTIVE	SOIC	D	16	2500	Green (RoHS & no Sb/Br)	CU NIPDAU	Level-1-260C-UNLIM	-40 to 85	LVDS105	<a href="#">Samples</a>
SN65LVDS105PW	ACTIVE	TSSOP	PW	16	90	Green (RoHS & no Sb/Br)	CU NIPDAU	Level-1-260C-UNLIM	-40 to 85	LVDS105	<a href="#">Samples</a>
SN65LVDS105PWG4	ACTIVE	TSSOP	PW	16	90	Green (RoHS & no Sb/Br)	CU NIPDAU	Level-1-260C-UNLIM	-40 to 85	LVDS105	<a href="#">Samples</a>
SN65LVDS105PWR	ACTIVE	TSSOP	PW	16	2000	Green (RoHS & no Sb/Br)	CU NIPDAU	Level-1-260C-UNLIM	-40 to 85	LVDS105	<a href="#">Samples</a>
SN65LVDS105PWRG4	ACTIVE	TSSOP	PW	16	2000	Green (RoHS & no Sb/Br)	CU NIPDAU	Level-1-260C-UNLIM	-40 to 85	LVDS105	<a href="#">Samples</a>

(1) The marketing status values are defined as follows:

**ACTIVE:** Product device recommended for new designs.

**LIFEBUY:** TI has announced that the device will be discontinued, and a lifetime-buy period is in effect.

**NRND:** Not recommended for new designs. Device is in production to support existing customers, but TI does not recommend using this part in a new design.

---

**PREVIEW:** Device has been announced but is not in production. Samples may or may not be available.

**OBSOLETE:** TI has discontinued the production of the device.

<sup>(2)</sup> Eco Plan - The planned eco-friendly classification: Pb-Free (RoHS), Pb-Free (RoHS Exempt), or Green (RoHS & no Sb/Br) - please check <http://www.ti.com/productcontent> for the latest availability information and additional product content details.

**TBD:** The Pb-Free/Green conversion plan has not been defined.

**Pb-Free (RoHS):** TI's terms "Lead-Free" or "Pb-Free" mean semiconductor products that are compatible with the current RoHS requirements for all 6 substances, including the requirement that lead not exceed 0.1% by weight in homogeneous materials. Where designed to be soldered at high temperatures, TI Pb-Free products are suitable for use in specified lead-free processes.

**Pb-Free (RoHS Exempt):** This component has a RoHS exemption for either 1) lead-based flip-chip solder bumps used between the die and package, or 2) lead-based die adhesive used between the die and leadframe. The component is otherwise considered Pb-Free (RoHS compatible) as defined above.

**Green (RoHS & no Sb/Br):** TI defines "Green" to mean Pb-Free (RoHS compatible), and free of Bromine (Br) and Antimony (Sb) based flame retardants (Br or Sb do not exceed 0.1% by weight in homogeneous material)

<sup>(3)</sup> MSL, Peak Temp. - The Moisture Sensitivity Level rating according to the JEDEC industry standard classifications, and peak solder temperature.

<sup>(4)</sup> There may be additional marking, which relates to the logo, the lot trace code information, or the environmental category on the device.

<sup>(5)</sup> Multiple Device Markings will be inside parentheses. Only one Device Marking contained in parentheses and separated by a "~" will appear on a device. If a line is indented then it is a continuation of the previous line and the two combined represent the entire Device Marking for that device.

<sup>(6)</sup> Lead/Ball Finish - Orderable Devices may have multiple material finish options. Finish options are separated by a vertical ruled line. Lead/Ball Finish values may wrap to two lines if the finish value exceeds the maximum column width.

**Important Information and Disclaimer:** The information provided on this page represents TI's knowledge and belief as of the date that it is provided. TI bases its knowledge and belief on information provided by third parties, and makes no representation or warranty as to the accuracy of such information. Efforts are underway to better integrate information from third parties. TI has taken and continues to take reasonable steps to provide representative and accurate information but may not have conducted destructive testing or chemical analysis on incoming materials and chemicals. TI and TI suppliers consider certain information to be proprietary, and thus CAS numbers and other limited information may not be available for release.

In no event shall TI's liability arising out of such information exceed the total purchase price of the TI part(s) at issue in this document sold by TI to Customer on an annual basis.

**TAPE AND REEL INFORMATION**

**QUADRANT ASSIGNMENTS FOR PIN 1 ORIENTATION IN TAPE**

\*All dimensions are nominal

Device	Package Type	Package Drawing	Pins	SPQ	Reel Diameter (mm)	Reel Width W1 (mm)	A0 (mm)	B0 (mm)	K0 (mm)	P1 (mm)	W (mm)	Pin1 Quadrant
SN65LVDS104DR	SOIC	D	16	2500	330.0	16.4	6.5	10.3	2.1	8.0	16.0	Q1
SN65LVDS104PWR	TSSOP	PW	16	2000	330.0	12.4	6.9	5.6	1.6	8.0	12.0	Q1
SN65LVDS105DR	SOIC	D	16	2500	330.0	16.4	6.5	10.3	2.1	8.0	16.0	Q1
SN65LVDS105PWR	TSSOP	PW	16	2000	330.0	12.4	6.9	5.6	1.6	8.0	12.0	Q1

**TAPE AND REEL BOX DIMENSIONS**

\*All dimensions are nominal

Device	Package Type	Package Drawing	Pins	SPQ	Length (mm)	Width (mm)	Height (mm)
SN65LVDS104DR	SOIC	D	16	2500	367.0	367.0	38.0
SN65LVDS104PWR	TSSOP	PW	16	2000	367.0	367.0	35.0
SN65LVDS105DR	SOIC	D	16	2500	367.0	367.0	38.0
SN65LVDS105PWR	TSSOP	PW	16	2000	367.0	367.0	35.0



D (R-PDSO-G16)

PLASTIC SMALL OUTLINE



4211283-4/E 08/12

- NOTES:
- A. All linear dimensions are in millimeters.
  - B. This drawing is subject to change without notice.
  - C. Publication IPC-7351 is recommended for alternate designs.
  - D. Laser cutting apertures with trapezoidal walls and also rounding corners will offer better paste release. Customers should contact their board assembly site for stencil design recommendations. Refer to IPC-7525 for other stencil recommendations.
  - E. Customers should contact their board fabrication site for solder mask tolerances between and around signal pads.

PW (R-PDSO-G16)

PLASTIC SMALL OUTLINE

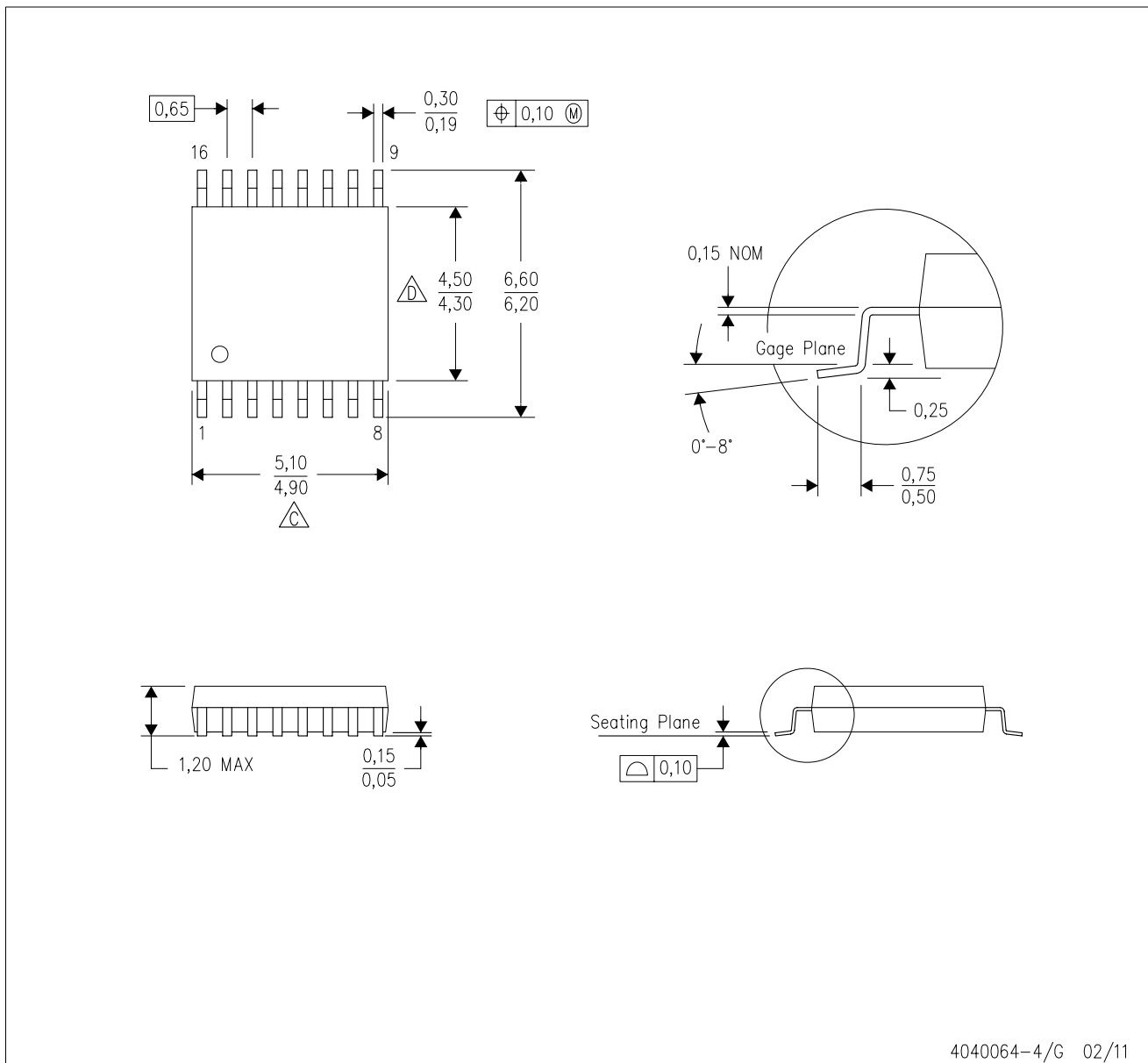

4040064-4/G 02/11

- NOTES:
- A. All linear dimensions are in millimeters. Dimensioning and tolerancing per ASME Y14.5M-1994.
  - B. This drawing is subject to change without notice.
  - C. Body length does not include mold flash, protrusions, or gate burrs. Mold flash, protrusions, or gate burrs shall not exceed 0,15 each side.
  - D. Body width does not include interlead flash. Interlead flash shall not exceed 0,25 each side.
  - E. Falls within JEDEC MO-153

PW (R-PDSO-G16)

PLASTIC SMALL OUTLINE

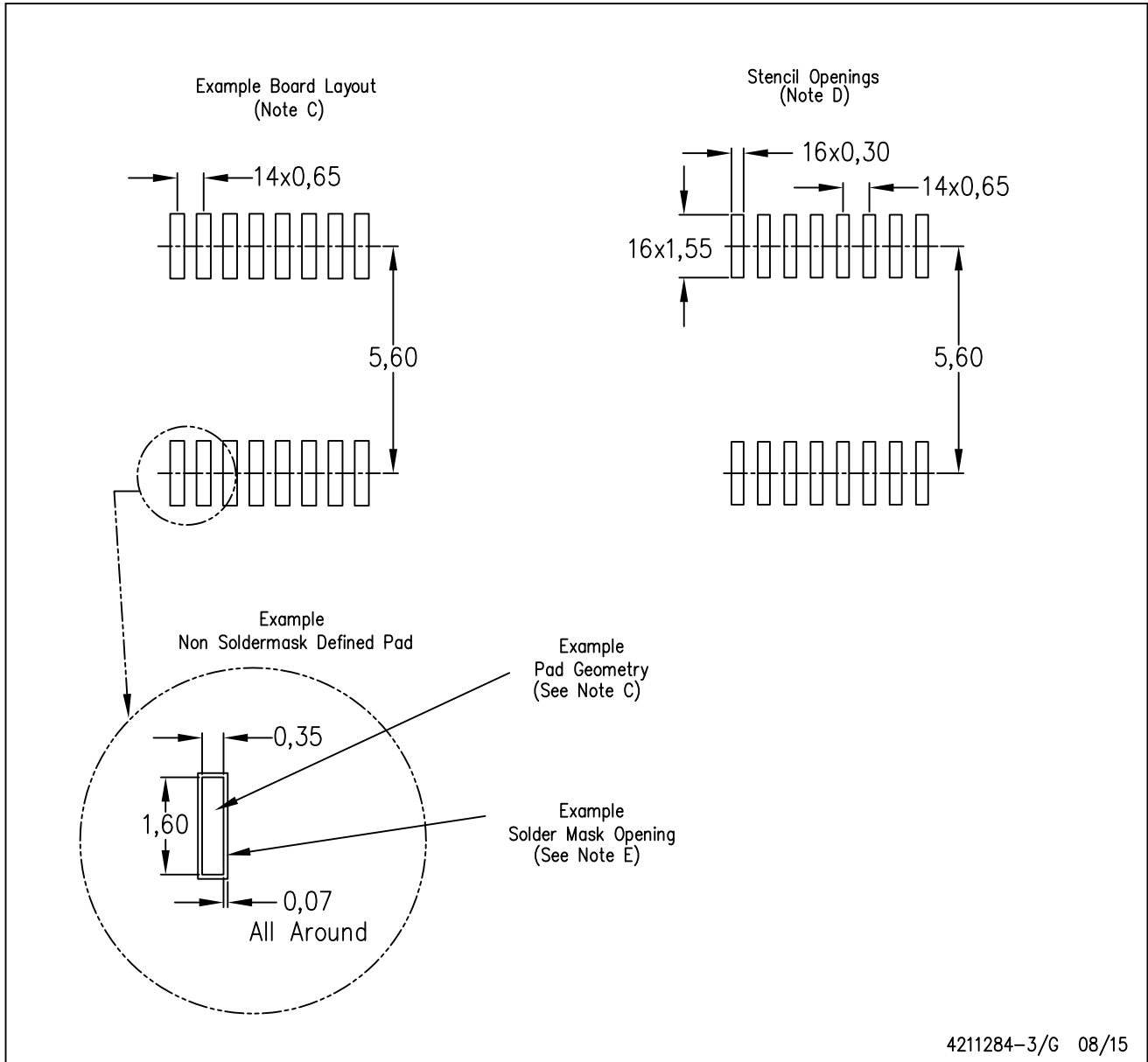

- NOTES:
- All linear dimensions are in millimeters.
  - This drawing is subject to change without notice.
  - Publication IPC-7351 is recommended for alternate designs.
  - Laser cutting apertures with trapezoidal walls and also rounding corners will offer better paste release. Customers should contact their board assembly site for stencil design recommendations. Refer to IPC-7525 for other stencil recommendations.
  - Customers should contact their board fabrication site for solder mask tolerances between and around signal pads.

## IMPORTANT NOTICE

Texas Instruments Incorporated and its subsidiaries (TI) reserve the right to make corrections, enhancements, improvements and other changes to its semiconductor products and services per JESD46, latest issue, and to discontinue any product or service per JESD48, latest issue. Buyers should obtain the latest relevant information before placing orders and should verify that such information is current and complete. All semiconductor products (also referred to herein as "components") are sold subject to TI's terms and conditions of sale supplied at the time of order acknowledgment.

TI warrants performance of its components to the specifications applicable at the time of sale, in accordance with the warranty in TI's terms and conditions of sale of semiconductor products. Testing and other quality control techniques are used to the extent TI deems necessary to support this warranty. Except where mandated by applicable law, testing of all parameters of each component is not necessarily performed.

TI assumes no liability for applications assistance or the design of Buyers' products. Buyers are responsible for their products and applications using TI components. To minimize the risks associated with Buyers' products and applications, Buyers should provide adequate design and operating safeguards.

TI does not warrant or represent that any license, either express or implied, is granted under any patent right, copyright, mask work right, or other intellectual property right relating to any combination, machine, or process in which TI components or services are used. Information published by TI regarding third-party products or services does not constitute a license to use such products or services or a warranty or endorsement thereof. Use of such information may require a license from a third party under the patents or other intellectual property of the third party, or a license from TI under the patents or other intellectual property of TI.

Reproduction of significant portions of TI information in TI data books or data sheets is permissible only if reproduction is without alteration and is accompanied by all associated warranties, conditions, limitations, and notices. TI is not responsible or liable for such altered documentation. Information of third parties may be subject to additional restrictions.

Resale of TI components or services with statements different from or beyond the parameters stated by TI for that component or service voids all express and any implied warranties for the associated TI component or service and is an unfair and deceptive business practice. TI is not responsible or liable for any such statements.

Buyer acknowledges and agrees that it is solely responsible for compliance with all legal, regulatory and safety-related requirements concerning its products, and any use of TI components in its applications, notwithstanding any applications-related information or support that may be provided by TI. Buyer represents and agrees that it has all the necessary expertise to create and implement safeguards which anticipate dangerous consequences of failures, monitor failures and their consequences, lessen the likelihood of failures that might cause harm and take appropriate remedial actions. Buyer will fully indemnify TI and its representatives against any damages arising out of the use of any TI components in safety-critical applications.

In some cases, TI components may be promoted specifically to facilitate safety-related applications. With such components, TI's goal is to help enable customers to design and create their own end-product solutions that meet applicable functional safety standards and requirements. Nonetheless, such components are subject to these terms.

No TI components are authorized for use in FDA Class III (or similar life-critical medical equipment) unless authorized officers of the parties have executed a special agreement specifically governing such use.

Only those TI components which TI has specifically designated as military grade or "enhanced plastic" are designed and intended for use in military/aerospace applications or environments. Buyer acknowledges and agrees that any military or aerospace use of TI components which have **not** been so designated is solely at the Buyer's risk, and that Buyer is solely responsible for compliance with all legal and regulatory requirements in connection with such use.

TI has specifically designated certain components as meeting ISO/TS16949 requirements, mainly for automotive use. In any case of use of non-designated products, TI will not be responsible for any failure to meet ISO/TS16949.

### Products

Audio	<a href="http://www.ti.com/audio">www.ti.com/audio</a>
Amplifiers	<a href="http://amplifier.ti.com">amplifier.ti.com</a>
Data Converters	<a href="http://dataconverter.ti.com">dataconverter.ti.com</a>
DLP® Products	<a href="http://www.dlp.com">www.dlp.com</a>
DSP	<a href="http://dsp.ti.com">dsp.ti.com</a>
Clocks and Timers	<a href="http://www.ti.com/clocks">www.ti.com/clocks</a>
Interface	<a href="http://interface.ti.com">interface.ti.com</a>
Logic	<a href="http://logic.ti.com">logic.ti.com</a>
Power Mgmt	<a href="http://power.ti.com">power.ti.com</a>
Microcontrollers	<a href="http://microcontroller.ti.com">microcontroller.ti.com</a>
RFID	<a href="http://www.ti-rfid.com">www.ti-rfid.com</a>
OMAP Applications Processors	<a href="http://www.ti.com/omap">www.ti.com/omap</a>
Wireless Connectivity	<a href="http://www.ti.com/wirelessconnectivity">www.ti.com/wirelessconnectivity</a>

### Applications

Automotive and Transportation	<a href="http://www.ti.com/automotive">www.ti.com/automotive</a>
Communications and Telecom	<a href="http://www.ti.com/communications">www.ti.com/communications</a>
Computers and Peripherals	<a href="http://www.ti.com/computers">www.ti.com/computers</a>
Consumer Electronics	<a href="http://www.ti.com/consumer-apps">www.ti.com/consumer-apps</a>
Energy and Lighting	<a href="http://www.ti.com/energy">www.ti.com/energy</a>
Industrial	<a href="http://www.ti.com/industrial">www.ti.com/industrial</a>
Medical	<a href="http://www.ti.com/medical">www.ti.com/medical</a>
Security	<a href="http://www.ti.com/security">www.ti.com/security</a>
Space, Avionics and Defense	<a href="http://www.ti.com/space-avionics-defense">www.ti.com/space-avionics-defense</a>
Video and Imaging	<a href="http://www.ti.com/video">www.ti.com/video</a>

### TI E2E Community

[e2e.ti.com](http://e2e.ti.com)