

PROGRAMMABLE 27-BIT PARALLEL-TO-SERIAL RECEIVER

FEATURES

- FlatLink 3G Serial Interface Technology
- Compatible With FlatLink™ 3G Transmitters Such as SN65LVDS307
- Supports Video Interfaces up to 24-Bit RGB Data and 3 Control Bits Received Over Two Differential Data Lines
- SubLVDS Differential Voltage Levels
- Up to 810-Mbps Data Throughput
- Three Operating Modes to Conserve Power
 - Active mode VGA 60 fps: 17 mW
 - Typical Shutdown: 0.7 μ W
 - Typical Standby Mode: 67 μ W Typical
- ESD Rating > 4 kV (HBM)
- Pixel-Clock Range of 8 MHz–30 MHz
- Failsafe on all CMOS Inputs
- 4-mm \times 4-mm MicroStar Junior™ μ BGA® Package With 0,5-mm Ball Pitch
- Very Low EMI

APPLICATIONS

- Small Low-Emission Interface Between Graphics Controller and LCD Display
- Mobile Phones and Smart Phones
- Portable Multimedia Players

DESCRIPTION

The SN65LVDS308 receiver deserializes FlatLink 3G-compliant serial input data to 27 parallel data outputs. The SN65LVDS308 receiver contains one shift register to load 30 bits from two serial inputs and latches the 24 pixel bits and 3 control bits out to the parallel CMOS outputs after checking the parity bit. If a parity error is detected, the data output bus disregards the newly received pixel. Instead, the last data word is held on the output bus for another clock cycle.

The serial data and clock are received via sub-low-voltage differential signalling (SubLVDS) lines. The SN65LVDS308 supports three operating power modes (shutdown, standby, and active) to conserve power.

When receiving, the PLL locks to the incoming clock, CLK, and generates an internal high-speed clock at the line rate of the data lines. The data is serially loaded into a shift register using the internal high-speed clock. The deserialized data is presented on the parallel output bus with a recreation of the pixel clock, PCLK, generated from the internal high-speed clock. If no input CLK signal is present, the output bus is held static with PCLK and DE held low, while all other parallel outputs are pulled high.

The F/S control input selects between a slow CMOS bus output rise time for best EMI and power consumption and a fast CMOS output for increased speed or higher-load designs.

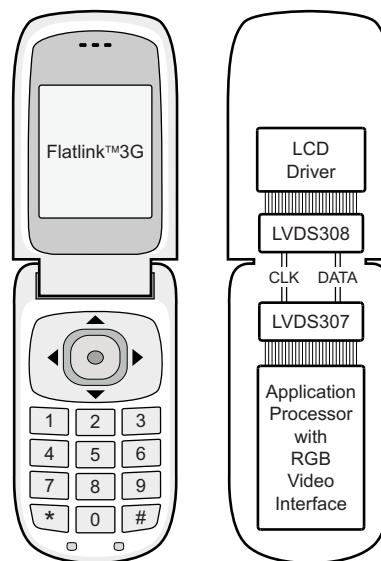

M0056-03



Please be aware that an important notice concerning availability, standard warranty, and use in critical applications of Texas Instruments semiconductor products and disclaimers thereto appears at the end of this data sheet.

FlatLink, MicroStar Junior are trademarks of Texas Instruments.
 μ BGA is a registered trademark of Tessera, Inc.



These devices have limited built-in ESD protection. The leads should be shorted together or the device placed in conductive foam during storage or handling to prevent electrostatic damage to the MOS gates.

DESCRIPTION (CONTINUED)

The RXEN input can be used to put the SN65LVDS308 in a shutdown mode. The SN65LVDS308 enters an active standby mode if the common-mode voltage of the CLK input becomes shifted to $V_{DD_{LVDS}}$ (e.g., the transmitter releases the CLK output into high-impedance). This minimizes power consumption without the need of switching an external control pin. The SN65LVDS308 is characterized for operation over ambient air temperatures of -40°C to 85°C . All CMOS and SubLVDS signals are 2-V tolerant with $V_{DD} = 0\text{ V}$. This feature allows powering up I/Os before V_{DD} is stabilized.

FUNCTIONAL BLOCK DIAGRAM

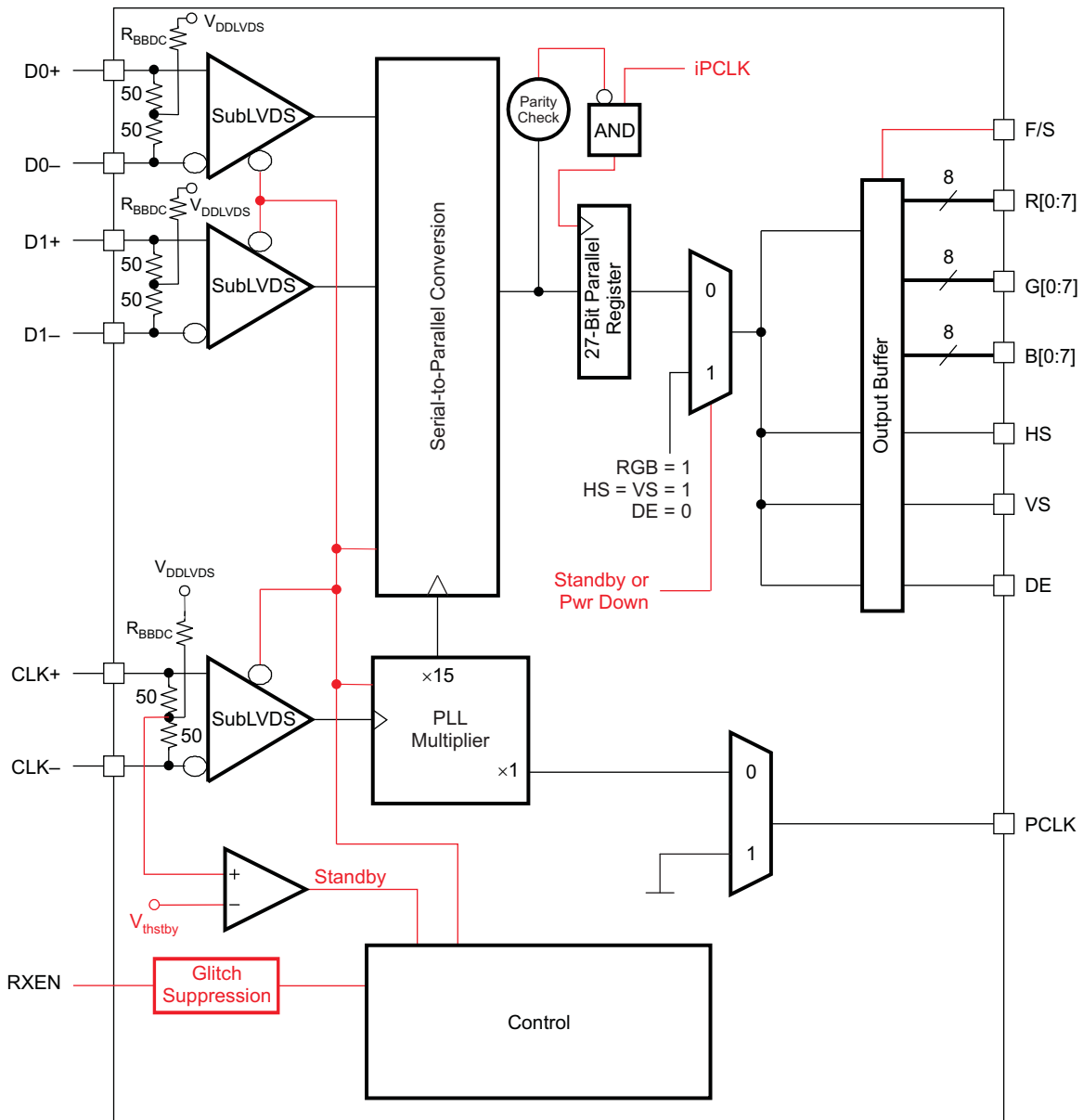

B0177-03

PINOUT – TOP VIEW

**ZQC PACKAGE
(TOP VIEW)**

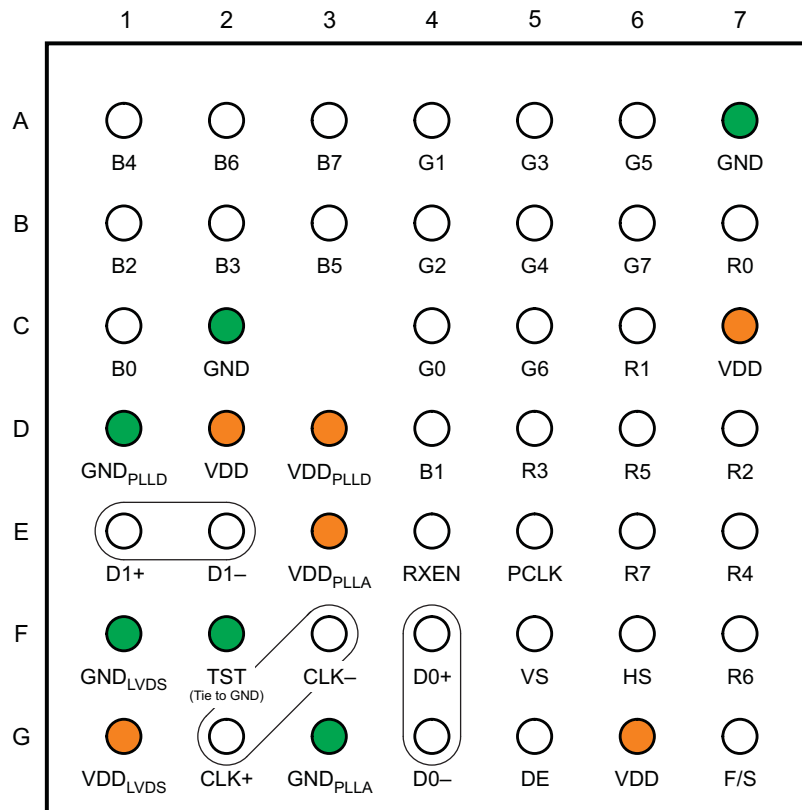

P0063-02

PINOUT – TOP VIEW (continued)**Table 1. Numeric Terminal List**

TERMINAL	SIGNAL	TERMINAL	SIGNAL	TERMINAL	SIGNAL	TERMINAL	SIGNAL
A1	B4	B7	R0	D6	R5	F5	VS
A2	B6	C1	B0	D7	R2	F6	HS
A3	B7	C2	GND	E1	D1+	F7	R6
A4	G1	C3	–	E2	D1–	G1	VDD _{LVDS}
A5	G3	C4	G0	E3	VDD _{PLLA}	G2	CLK+
A6	G5	C5	G6	E4	RXEN	G3	GND _{PLLA}
A7	GND	C6	R1	E5	PCLK	G4	D0–
B1	B2	C7	VDD	E6	R7	G5	DE
B2	B3	D1	GND _{PLLD}	E7	R4	G6	VDD
B3	B5	D2	VDD	F1	GND _{LVDS}	G7	F/S
B4	G2	D3	VDD _{PLLD}	F2	TST		
B5	G4	D4	B1	F3	CLK–		
B6	G7	D5	R3	F4	D0+		

Table 2. TERMINAL FUNCTIONS

NAME	I/O	DESCRIPTION
D0+, D0–	SubLVDS in	SubLVDS data link
D1+, D1–		SubLVDS data link
CLK+, CLK–		SubLVDS input pixel clock; polarity is fixed.
R0–R7	CMOS out	Red-pixel data (8)
G0–G7		Green-pixel data (8)
B0–B7		Blue-pixel data (8)
HS		Horizontal sync
VS		Vertical sync
DE		Data enable
PCLK		Output pixel clock (rising clock polarity)
RXEN		CMOS in
F/S	CMOS bus rise time select 1 – fast-output rise time 0 – slow-output rise time	
TST	Test – this input is used for TI internal test purposes only and must be tied permanently to VSS.	
VDD	Power supply	Supply voltage
GND		Supply ground
VDD _{LVDS}		SubLVDS I/O supply voltage
GND _{LVDS}		SubLVDS ground
VDD _{PLLA}		PLL analog supply voltage
GND _{PLLA}		PLL analog GND
VDD _{PLLD}		PLL digital supply voltage
GND _{PLLD}		PLL digital GND

FUNCTIONAL DESCRIPTION

The SN65LVDS308 receives payload data over two SubLVDS data pairs, D0 and D1. The PLL locks to the SubLVDS clock input and internally multiplies the clock by a factor of 15. The internal high-speed clock is used to shift in the data payload on D0 and D1 and to deserialize 15 bits of data from each pair. Figure 1 illustrates the timing and the mapping of the data payload into the 30-bit frame. The internal high-speed clock is divided by a factor of 15 to recreate the pixel clock, and the data payload with pixel clock is presented on the output bus. The reserved bits and parity bit are not output.

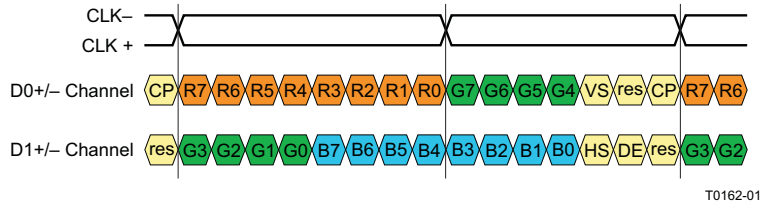

Figure 1. Data and Clock Input

POWER-DOWN MODES

The SN65LVDS308 receiver has two power-down modes to facilitate efficient power management.

Shutdown Mode

A low input signal on the RXEN pin puts the SN65LVDS308 into shutdown mode. This turns off most of the receiver circuitry, including the SubLVDS receivers, PLL, and deserializers. The SubLVDS differential-input resistance remains 100 Ω , and any input signal is ignored. All outputs hold a static output pattern:

$$R[0:7] = G[0:7] = B[0:7] = VS = HS = \text{high}; DE = PCLK = \text{low}.$$

The current draw in shutdown mode is nearly zero if the SubLVDS inputs are left open or pulled high.

Standby Mode

The SN65LVDS308 enters the standby mode when the SN65LVDS308 is not in shutdown mode but the clock-input common-mode voltage on the SubLVDS clock input is above $0.9 \times VDD_{LVDS}$. The CLK input incorporates pullup circuitry. This circuit shifts the SubLVDS clock-input common-mode voltage to VDD_{LVDS} in the absence of an input signal. All circuitry except the SubLVDS clock-input standby monitor is shut down. The SN65LVDS308 also enters the standby mode when the input clock frequency on the CLK input is less than 500 kHz. The SubLVDS input resistance remains 100 Ω , and any input signal on data inputs D0 and D1 is ignored. All outputs hold a static output pattern:

$$R[0:7] = G[0:7] = B[0:7] = VS = HS = \text{high}; DE = PCLK = \text{low}.$$

The current draw in standby mode is very low.

ACTIVE MODES

A high input signal on RXEN combined with a CLK input signal switching faster than 3 MHz and V_{ICM} smaller than 0.9 VDD forces the SN65LVDS308 into the active mode. Current consumption in the active mode depends on operating frequency and the number of data transitions in the data payload. CLK-input frequencies between 3 MHz and 8 MHz activate the device, but proper PLL functionality is not assured.

Acquire Mode (PLL Approaches Lock)

When the SN65LVDS308 is enabled and a SubLVDS clock input is present, the PLL pursues lock to the input clock. While the PLL pursues lock, the output data bus holds a static output pattern:

$$R[0:7] = G[0:7] = B[0:7] = VS = HS = \text{high}; DE = PCLK = \text{low}.$$

FUNCTIONAL DESCRIPTION (continued)

For proper device operation, the pixel clock frequency must fall within the valid f_{PCLK} range specified under recommended operating conditions. If the pixel clock frequency is larger than 3 MHz but smaller than $f_{PCLK(min)}$, the SN65LVDS308 PLL is enabled. Under such conditions, it is possible for the PLL to lock temporarily to the pixel clock, causing the PLL monitor to release the device into active receive mode. If this happens, the PLL may or may not be properly locked to the pixel clock input, potentially causing data errors, frequency oscillation, and PLL deadlock (loss of VCO oscillation).

Receive Mode

After the PLL achieves lock the device enters the normal receive mode. The output data bus presents the deserialized data. The PCLK output pin outputs the recovered pixel clock.

PARITY ERROR DETECTION AND HANDLING

The SN65LVDS308 receiver performs error checking on the basis of a parity bit that is transmitted across the SubLVDS interface from the transmitting device. Once the SN65LVDS308 detects the presence of the clock and the PLL has locked onto PCLK, then the parity is checked. Parity-error detection ensures detection of all single-bit errors in one pixel and 50% of all multibit errors.

The parity bit covers the 27-bit data payload consisting of 24 bits of pixel data plus VS, HS, and DE. Odd-parity bit signalling is used. If the sum of the 27 data bits and the parity bit is an odd number, the receive data are assumed to be valid. If the sum equals an even number, parity error is declared.

If a parity error is detected, then the data on that PCLK cycle is not output. Instead, the last valid data from a previous PCLK cycle is repeated on the output bus. This is to prevent any bit error that occurs on the LVDS link from causing perturbations in VS, HS, or DE that might be visually disruptive to a display.

The reserved bits are not covered in the parity calculations.

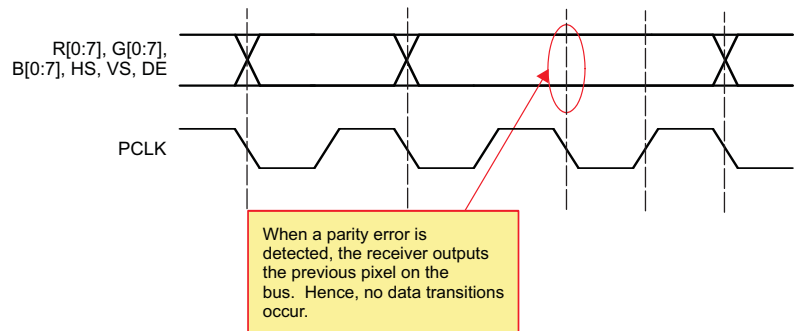

T0163-02

Figure 2. Output Response When Parity Error Is Detected

FUNCTIONAL DESCRIPTION (continued)

STATUS-DETECT AND OPERATING-MODES FLOW DIAGRAM

The SN65LVDS308 switches between the power saving and active modes in the following way:

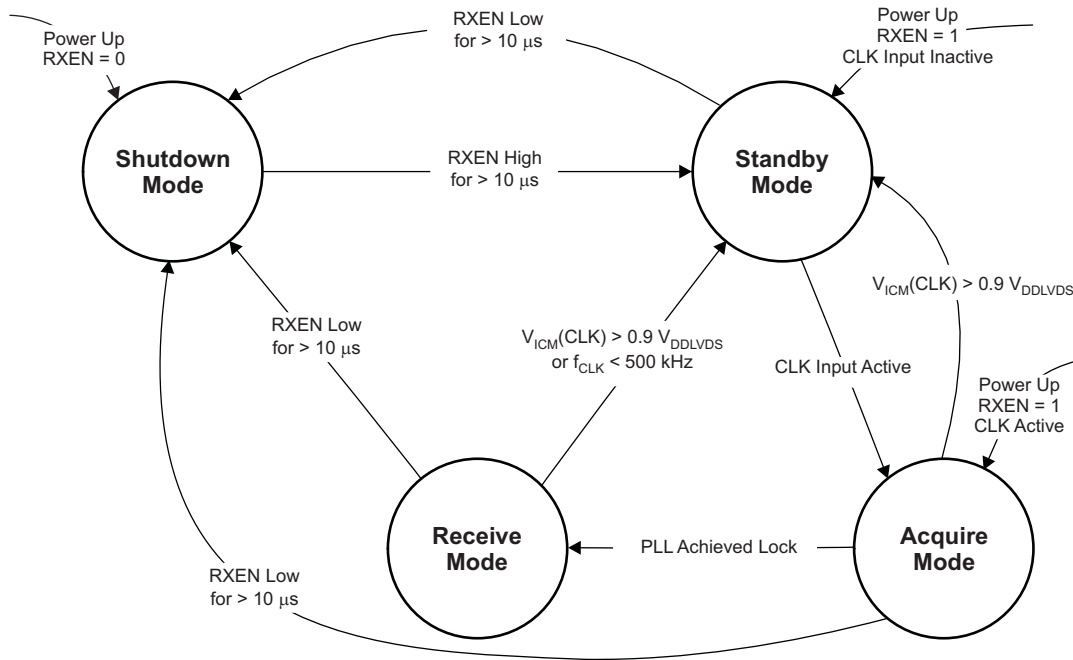

F0017-01

Figure 3. Operating Modes Flow Diagram

Table 3. Status Detect and Operating Modes Descriptions

MODE	CHARACTERISTICS	CONDITIONS
Shutdown mode	Least amount of power consumption (most circuitry turned off); all outputs held static: R[0:7] = G[0:7] = B[0:7] = VS = HS = high; DE = PCLK = low	RXEN is set low for longer than 10 μs. (1)(2)
Standby mode	Low power consumption (standby monitor circuit active; PLL is shut down to conserve power); All outputs held static: R[0:7] = G[0:7] = B[0:7] = VS = HS = high; DE = PCLK = low	RXEN is high for longer than 10 μs and both CLK inputs are common-mode, V _{ICM(CLK)} is above 0.9 × V _{DDLVDs} , or CLK inputs are floating (2)
Acquire mode	PLL pursues lock; all outputs held static: R[0:7] = G[0:7] = B[0:7] = VS = HS = high; DE = PCLK = low	RXEN is high; CLK input monitor detected clock input common mode and woke up receiver from standby mode.
Receive mode	Data transfer (normal operation); receiver deserializes data and provides data on parallel output	RXEN is high and PLL is locked to incoming clock.

- (1) In shutdown mode, all SN65LVDS308 internal switching circuits (e.g., PLL, serializer, etc.) are turned off to minimize power consumption. The input stage of any input pin remains active.
- (2) Leaving inputs unconnected can cause random noise to toggle the input stage and potentially harm the device. All CMOS inputs must be tied to a valid logic level, V_{IL} or V_{IH}, during shutdown or standby mode. Exceptions are the SubLVDS inputs CLK and Dx, which can be left unconnected while not in use.

Table 4. Operating Mode Transitions

MODE TRANSITION	USE CASE	TRANSITION SPECIFICS
Shutdown → standby	Drive RXEN high to enable receiver.	<ol style="list-style-type: none"> 1. RXEN high > 10 μs 2. Receiver enters standby mode. <ol style="list-style-type: none"> a. R[0:7] = G[0:7] = B[0:7] = VS = HS remain high and DE = PCLK low b. Receiver activates clock input monitor.
Standby → acquire	Transmitter activity detected	<ol style="list-style-type: none"> 1. CLK input monitor detects clock input activity. 2. Outputs remain static. 3. PLL circuit is enabled.
Acquire → receive	Link is ready to receive data.	<ol style="list-style-type: none"> 1. PLL is active and approaches lock. 2. PLL achieves lock within t_{wakeUp}. 3. First data word is recovered. 4. Parallel output bus turns on switching from a static output pattern to output the first valid data word.
Receive → standby	Transmitter requested to enter standby mode by input common-mode voltage $V_{\text{ICM}} > 0.9 V_{\text{DDLVDs}}$ (e.g., transmitter output clock enters high-impedance state)	<ol style="list-style-type: none"> 1. Receiver disables outputs within t_{sleep}. 2. RX input monitor detects $V_{\text{ICM}} > 0.9 V_{\text{DDLVDs}}$. 3. R[0:7] = G[0:7] = B[0:7] = VS = HS transition to high and DE = PCLK to low on next falling PLL clock edge. 4. PLL shuts down. 5. Clock activity input monitor remains active.
Receive/standby → shutdown	Turn off receiver.	<ol style="list-style-type: none"> 1. RXEN pulled low for > t_{pwrDn}. 2. Receiver switches all outputs to high-impedance state. 3. Most IC circuitry is shut down for least power consumption.

ABSOLUTE MAXIMUM RATINGS⁽¹⁾

		VALUE	UNIT
Supply voltage range, VDD ⁽²⁾ , VDD _{PLLA} , VDD _{PLLD} , VDD _{LVDS}		–0.3 to 2.175	V
Voltage range at any input or output terminal	When VDD _x > 0 V	–0.5 to 2.175	V
	When VDD _x ≤ 0 V	–0.5 to VDD + 2.175	
Electrostatic discharge	Human body model ⁽³⁾ (all pins)	±4	kV
	Charged-device model ⁽⁴⁾ (all pins)	±1500	V
	Machine model ⁽⁵⁾ (all pins)	±200	
Continuous power dissipation		See Dissipation Ratings Table	
Output current, I _O		±5	mA

(1) Stresses beyond those listed under *absolute maximum ratings* may cause permanent damage to the device. These are stress ratings only and functional operation of the device at these or any other conditions beyond those indicated under *recommended operating conditions* is not implied. Exposure to absolute maximum-rated conditions for extended periods may affect device reliability.

(2) All voltage values are with respect to the GND terminals.

(3) In accordance with JEDEC Standard 22, Test Method A114-B

(4) In accordance with JEDEC Standard 22, Test Method C101

(5) In accordance with JEDEC Standard 22, Test Method A115-A

DISSIPATION RATINGS

PACKAGE	CIRCUIT BOARD MODEL	T _A < 25°C	DERATING FACTOR ⁽¹⁾ ABOVE T _A = 25°C	T _A = 85°C POWER RATING
ZQC	Low-K ⁽²⁾	496 mW	6.21 mW/°C	124 mW

(1) This is the inverse of the junction-to-ambient thermal resistance when board-mounted and with no air flow.

(2) In accordance with the low-K thermal metric definitions of EIA/JESD51-2.

DEVICE POWER DISSIPATION

PARAMETER	TEST CONDITIONS	TYP	MAX	UNIT
P _D Device power dissipation	VDD _x = 1.8 V, T _A = 25°C, all outputs terminated with 10 pF, f _{CLK} at 8 MHz	11.5		mW
	VDD _x = 1.95 V, T _A = –40°C, all outputs terminated with 10 pF, f _{CLK} at 30 MHz		72.2	

RECOMMENDED OPERATING CONDITIONS⁽¹⁾

		MIN	TYP	MAX	UNIT	
VDD VDD _{PLLA} VDD _{PLLD} VDD _{LVDS}	Supply voltages	1.65	1.8	1.95	V	
VDD _{n(PP)}	Supply voltage noise magnitude	Test setup shown in Figure 5; f(noise) = 1Hz to 2 GHz		100	mV	
		f(noise) = 1Hz to 1MHz		100		
		f(noise) > 1MHz		40		
T _A	Operating free-air temperature	-40		85	°C	
CLK+ and CLK-						
f _{CLK±}	Input pixel clock frequency	See Figure 1		8	30	MHz
		Standby mode ⁽²⁾ , see Figure 14			500	kHz
t _{DUTCLK}	CLK input duty cycle		35	65	%	
D0+, D0-, D1+, D1-, CLK+, and CLK-						
V _{ID}	Magnitude of differential input voltage	V _{D0+} - V _{D0-} , V _{D1+} - V _{D1-} , V _{CLK+} - V _{CLK-} during normal operation		70	200	mV
V _{ICM}	Input voltage common mode range	Receive or acquire mode		0.6	1.2	V
		Standby mode		VDD _{LVDS}		
ΔV _{ICM}	Input voltage common mode variation among all SubLVDS inputs	V _{ICM(n)} - V _{ICM(m)} with n = D0, D1, or CLK and m = D0, D1, or CLK		-100	100	mV
ΔV _{ID}	Differential input voltage amplitude variation among all SubLVDS inputs	V _{ID(n)} - V _{ID(m)} with n = D0, D1, or CLK and m = D0, D1, or CLK		-10	10	%
t _{r/f}	Input rise and fall times	RXEN at VDD; see Figure 8			800	ps
Δt _{r/f}	Input rise or fall time mismatch among all SubLVDS inputs	t _{r(n)} - t _{r(m)} and t _{f(n)} - t _{f(m)} with n = D0, D1, or CLK and m = D0, D1, or CLK		-100	100	ps
RXEN, F/S						
V _{ICMOSH}	High-level input voltage	0.7 VDD		VDD	V	
V _{ICMOSL}	Low-level input voltage	0		0.3 VDD	V	
t _{inRXEN}	RXEN input pulse duration	10			μs	
R[7:0], G[7:0], B[7:0], VS, HS, PCLK						
C _L	Output load capacitance			10	pF	

- (1) Unused single-ended inputs must be held high or low to prevent them from floating.
(2) PCLK input frequencies lower than 500 kHz force the SN65LVDS308 into standby mode. Input frequencies between 500 kHz and 3 MHz may or may not activate the SN65LVDS308. Input frequencies beyond 3 MHz activate the SN65LVDS308. Input frequencies between 500 kHz and 4 MHz are not recommended, and can cause PLL malfunction.

DEVICE ELECTRICAL CHARACTERISTICS

over recommended operating conditions (unless otherwise noted)

PARAMETER	TEST CONDITIONS	MIN	TYP ⁽¹⁾	MAX	UNIT
I _D D RMS supply current	Alternating 1010 test pattern (see Table 8***); all CMOS outputs terminated with 10 pF; F/S and RXEN at VDD; V _{IH} = VDD, V _{IL} = 0 V; VDD = VDD _{PLLA} = VDD _{PLLD} = VDD _{LVDS}	f _{PCLK} = 8 MHz	14.3	19.4	mA
		f _{PCLK} = 22 MHz	25	33	
		f _{PCLK} = 30 MHz	26.8	37	
	Typical power test pattern (see Table 6); V _{ID} = 70 mV, all CMOS outputs terminated with 10 pF; F/S at GND and RXEN at VDD; V _{IH} = VDD, V _{IL} = 0 V; VDD = VDD _{PLLA} = VDD _{PLLD} = VDD _{LVDS}	f _{PCLK} = 8 MHz		6.4	mA
		f _{PCLK} = 22 MHz		13.7	
		f _{PCLK} = 30 MHz		18.3	
CLK and Dx inputs are left open; all control inputs held static high or low; All CMOS outputs terminated with 10 pF; V _{IH} = VDD, V _{IL} = 0 V; VDD = VDD _{PLLA} = VDD _{PLLD} = VDD _{LVDS}	Standby mode; RXEN = V _{IH}		15	100	μA
	Shutdown mode; RXEN = V _{IL}		0.4	10	

- (1) All typical values are at 25°C and with 1.8-V supply, unless otherwise noted.

INPUT ELECTRICAL CHARACTERISTICS

over operating free-air temperature range (unless otherwise noted)

PARAMETER	TEST CONDITIONS	MIN	TYP ⁽¹⁾	MAX	UNIT	
D0+, D0-, D1+, D1-, CLK+, and CLK-						
V_{thstby}	Input voltage common mode threshold to switch between receive/acquire mode and standby mode		1.3	0.9 VDD _{LVDS}	V	
V_{THL}	Low-level differential input voltage threshold	$V_{D0+} - V_{D0-}$, $V_{D1+} - V_{D1-}$, $V_{CLK+} - V_{CLK-}$	-40		mV	
V_{THH}	High-level differential input voltage threshold			40	mV	
I_{I+} , I_{I-}	Input leakage current	VDD = 1.95 V; $V_{I+} = V_{I-}$; $V_I = 0.4$ V or $V_I = 1.5$ V		75	μ A	
I_{IOFF}	Power-off input current	VDD = GND; $V_I = 1.5$ V		-75	μ A	
R_{ID}	Differential input termination resistor value		78	100	122	Ω
C_{IN}	Input capacitance	Measured between input terminal and GND		1		pF
ΔC_{IN}	Input capacitance variation	Within one signal pair		0.2		pF
		Between all signals		1		
R_{BBDC}	Pullup resistor for standby detection		21	30	39	k Ω
RXEN, F/S						
V_{IK}	Input clamp voltage	$I_I = -18$ mA, VDD = VDD(min)		-1.2		V
I_{ICMOS}	Input current ⁽²⁾	0 V \leq VDD \leq 1.95 V; $V_I =$ GND or $V_I = 1.95$ V		100		nA
C_{IN}	Input capacitance			2		pF
I_{IH}	High-level input current	$V_{IN} = 0.7$ VDD	-200	200		nA
I_{IL}	Low-level input current	$V_{IN} = 0.3$ VDD	-200	200		
V_{IH}	High-level input voltage		0.7 VDD	VDD		V
V_{IL}	Low-level input voltage		0	0.3 VDD		

(1) All typical values are at 25°C and with 1.8-V supply unless otherwise noted.

(2) Do not leave any CMOS input unconnected or floating to minimize leakage currents. Every input must be connected to a valid logic level, V_{IH} or V_{OL} , while power is supplied to VDD.

OUTPUT ELECTRICAL CHARACTERISTICS

over operating free-air temperature range (unless otherwise noted)

PARAMETER	TEST CONDITIONS	MIN	TYP	MAX	UNIT
R[0:7], G[0:7], B[0:7], VS, HS, PCLK					
V_{OH}	High-level output current	F/S = L, $I_{OH} = -500$ μ A	0.8 VDD	VDD	V
		F/S = H, $I_{OH} = -2$ mA			
V_{OL}	Low-level output current	F/S = L, $I_{OL} = 500$ μ A	0	0.2 VDD	V
		F/S = H, $I_{OL} = 2$ mA			
I_{OH}	High-level output current	F/S = L	-500		μ A
		F/S = H	-2000		
I_{OL}	Low-level output current	F/S = L		500	μ A
		F/S = H		2000	

SWITCHING CHARACTERISTICS

over recommended operating conditions (unless otherwise noted)

PARAMETER	TEST CONDITIONS	MIN	TYP ⁽¹⁾	MAX	UNIT			
D0+, D0–, D1+, D1–, CLK+, and CLK–								
$t_{r/f}$	Input rise and fall times	RXEN at VDD; see Figure 8			800	ps		
$\Delta t_{r/f}$	Input rise or fall time mismatch between all SubLVDS inputs	$t_r(n) - t_r(m)$ and $t_f(n) - t_f(m)$ with $n = D0, D1,$ or CLK and $m = D0, D1,$ or CLK			–100	100	ps	
R[7:0], G[7:0], B[7:0], VS, HS, PCLK								
$t_{r/f}$	Rise and fall time 20%–80% of VDD ⁽²⁾	$C_L = 10$ pF ⁽³⁾ ; see Figure 7	F/S = L	4	8	ns		
			F/S = H	1	2			
t_{OUTP}	PCLK output duty cycle				48%	53%	59%	
t_{OSK}	Output skew between PCLK and R[0:7], G[0:7], B[0:7], HS, VS, and DE	See Figure 7.			–500	500	ps	
INPUT-TO-OUTPUT RESPONSE TIME								
$t_{PD(L)}$	Propagation delay time from CLK+ input to PCLK output	RXEN at VDD, $V_{IH} = VDD,$ $V_{IL} = GND,$ $C_L = 10$ pF, see Figure 12			$1.4/f_{PCLK}$	$1.9/f_{PCLK}$	$2.5/f_{PCLK}$	s
t_{GS}	RXEN glitch suppression pulse width ⁽⁴⁾	$V_{IH} = VDD,$ $V_{IL} = GND,$ RXEN toggles between V_{IL} and V_{IH} ; see Figure 13 and Figure 14.			3.8		μ s	
t_{pwrap}	Enable time from power down (\uparrow RXEN)	Time from RXEN pulled high to data outputs enabled and transmit valid data; see Figure 14.			2		ms	
t_{pwrdn}	Disable time from active mode (\downarrow RXEN)	RXEN is pulled low during receive mode; time measurement until all outputs held static: R[0:7] = G[0:7] = B[0:7] = VS = HS = high, DE = PCLK = low and PLL is shut down; see Figure 14.			11		μ s	
t_{wakeup}	Enable time from standby (\uparrow CLK)	RXEN at VDD; device is in standby; time measurement from CLK input start of switching until PCLK and data outputs enabled and transmitting valid data; see Figure 15.			2		ms	
t_{sleep}	Disable time from active mode (CLK transitions to high-impedance)	RXEN at VDD; device is receiving data; time measurement from CLK input signal stops (input open or input common mode V_{ICM} exceeds threshold voltage V_{thstby}) until all outputs held static: R[0:7] = G[0:7] = B[0:7] = VS = HS = high; DE = PCLK = low and PLL is shut down; see Figure 15.			3		μ s	
f_{BW}	PLL bandwidth ⁽⁵⁾	Tested from CLK input to PCLK output; $f_{PCLK} = 22$ MHz			$0.087 f_{PCLK}$		MHz	

- (1) All typical values are at 25°C and with 1.8-V supply, unless otherwise noted.
- (2) $t_{r/f}$ depends on the F/S setting and the capacitive load connected to each output. Some application information of how to calculate $t_{r/f}$ based on the output load and how to estimate the timing budget to interconnect to an LCD driver are provided in the application section near the end of this data sheet.
- (3) The output rise and fall times are optimized for an output load of 10 pF. The rise and fall times can be adjusted by changing the output load capacitance.
- (4) The RXEN input incorporates glitch-suppression logic to disregard short input pulses. t_{GS} is the duration of either a high-to-low or low-to-high transition that is suppressed.
- (5) When using the SN65LVDS308 receiver in conjunction with the SN65LVDS307 transmitter in one link, the PLL bandwidth of the SN65LVDS308 receiver always exceeds the bandwidth of the SN65LVDS307 transmit PLL. This ensures stable PLL tracking under all operating conditions and maximizes the receiver skew margin.

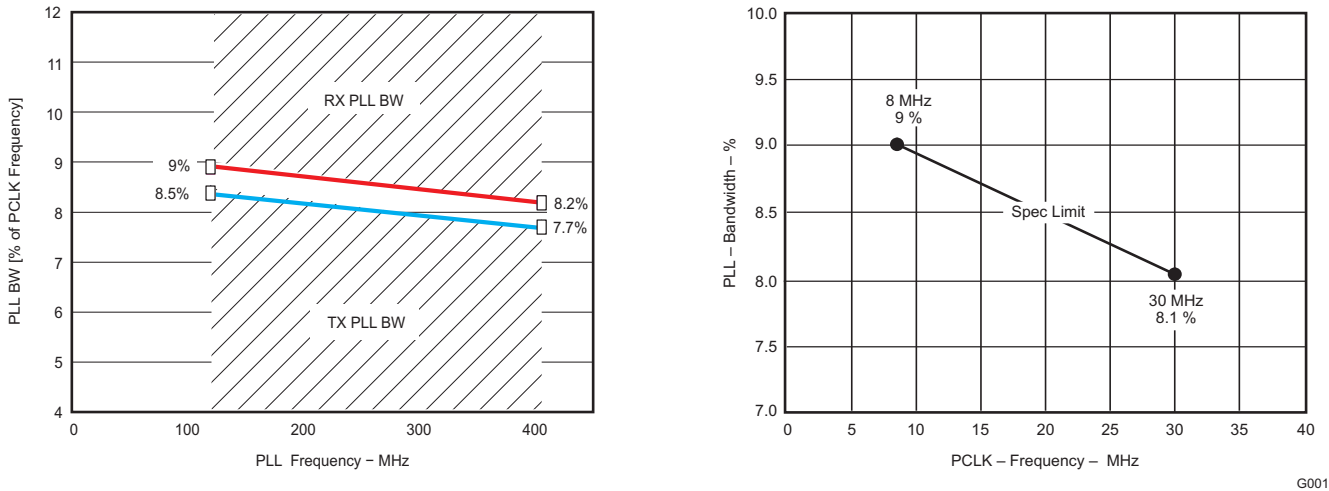

Figure 4. SN65LVDS308 PLL Bandwidth (Also Showing the SN65LVDS307 PLL Bandwidth)

TIMING CHARACTERISTICS

PARAMETER	TEST CONDITIONS	MIN	MAX	UNIT	
t_{RSKMx} (1)(2)	Receiver input skew margin; See (3) and Figure 30	$x = 0..14,$ $f_{PCLK} = 30$ MHz RXEN at VDD, $V_{IH} = VDD,$ $V_{IL} =$ GND, $R_L = 100 \Omega,$ test setup as in Figure 6, test pattern as in Table 9	$f_{CLK} = 30$ MHz ⁽⁴⁾	630	ps
		$f_{CLK} = 8$ MHz to 30 MHz ⁽⁵⁾	$\frac{1}{2 \cdot 15 \cdot f_{CLK}} - 480$ ps		

- (1) Receiver input skew margin (t_{RSKM}) is the timing margin available for transmitter output pulse position (t_{PPOS}), interconnect skew, and interconnect inter-symbol interference. t_{RSKM} represents the remainder of the serial bit time not taken up by the receiver strobe uncertainty. t_{RSKM} assumes a bit error rate better than 10^{-12} .
- (2) t_{RSKM} is inversely proportional to the internal setup and hold time uncertainty, ISI and duty cycle distortion from the front end receiver, the skew mismatch between CLK and data D0 and D1, as well as the PLL cycle-to-cycle jitter.
- (3) This includes the receiver internal setup and hold time uncertainty, all PLL-related high-frequency random and deterministic jitter components that impact the jitter budget, ISI and duty cycle distortion from the front-end receiver, and the skew between CLK and data D0 and D1; the pulse position minimum/maximum variation is given with a bit error rate target of 10^{-12} ; measurements of the total jitter are taken over $>10^{12}$ samples.
- (4) The minimum and maximum limits are based on statistical analysis of the device performance over process, voltage, and temperature ranges.
- (5) These minimum and maximum limits are simulated only.

PARAMETER MEASUREMENT INFORMATION

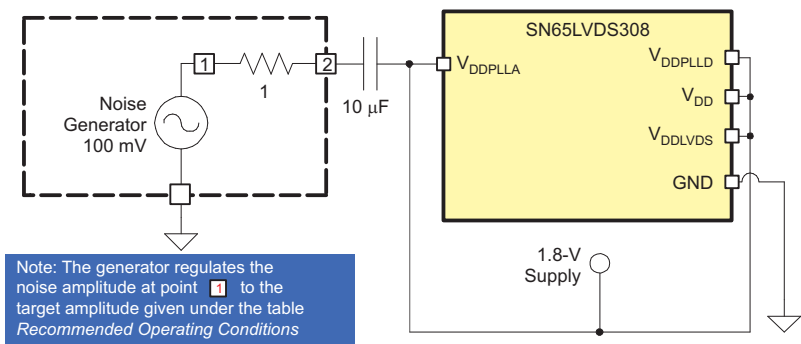
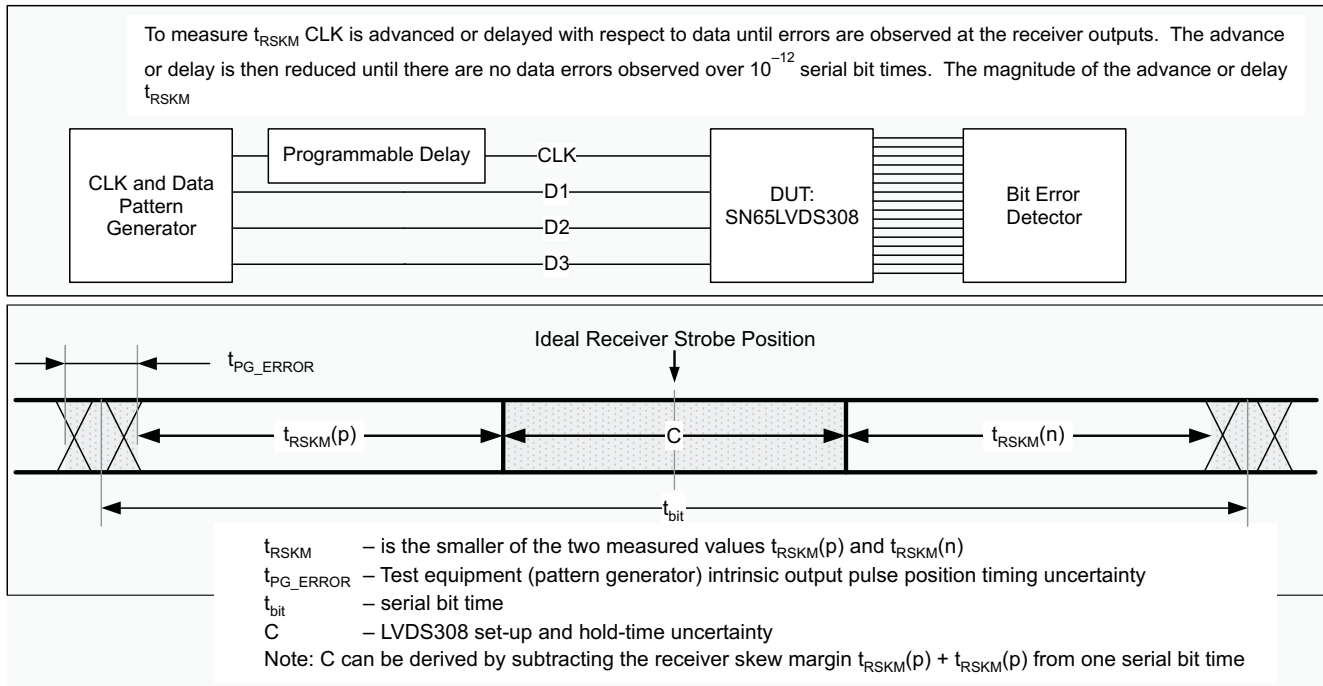

Figure 5. Power-Supply Noise Test Setup

PARAMETER MEASUREMENT INFORMATION (continued)



T0164-03

Figure 6. Receiver Jitter-Budget Test Setup

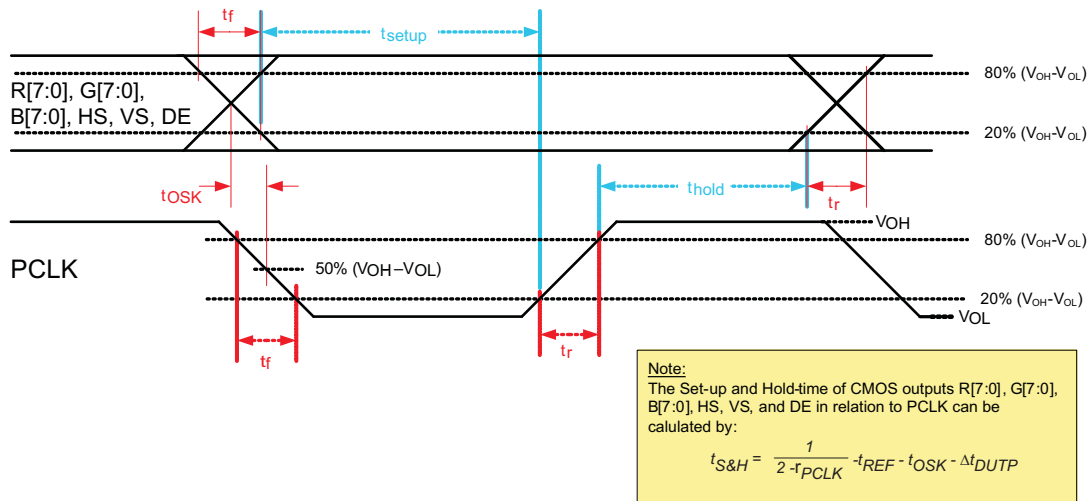

T0256-01

Figure 7. Output Rise/Fall, Setup/Hold Time

PARAMETER MEASUREMENT INFORMATION (continued)

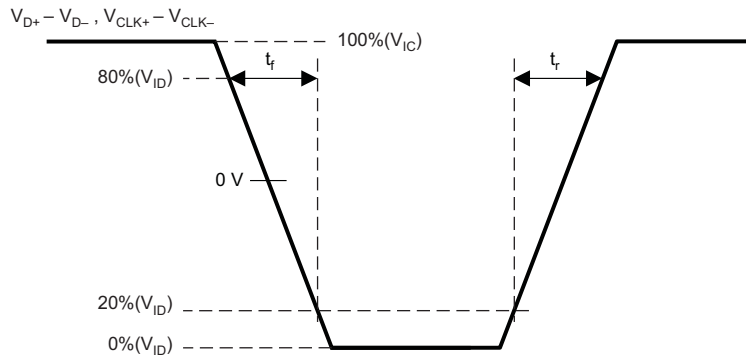

T0167-01

Figure 8. SubLVDS Differential Input Rise and Fall Time Definition

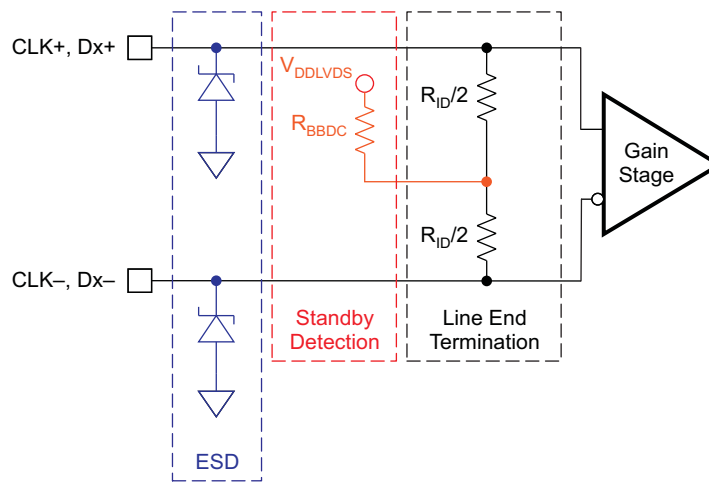

S0224-02

Figure 9. Equivalent Input Circuit Design

PARAMETER MEASUREMENT INFORMATION (continued)

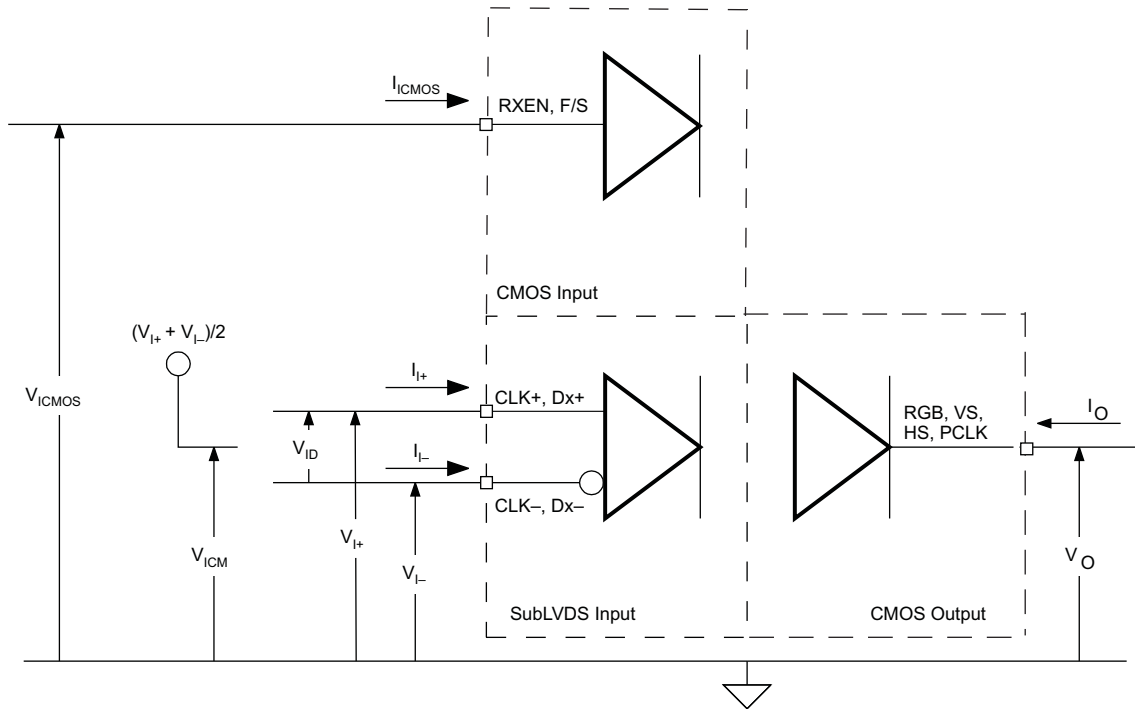

S0217-03

Figure 10. I/O Voltage and Current Definition

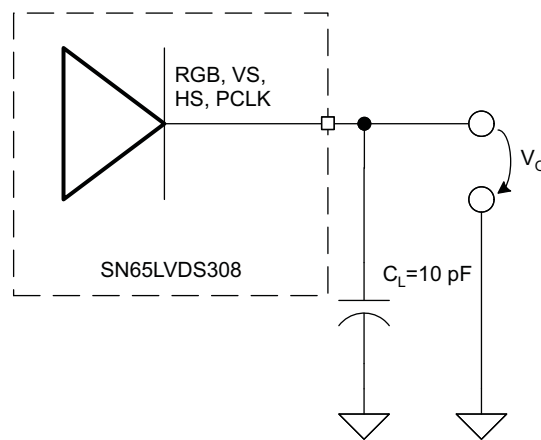

S0218-03

Figure 11. CMOS Output Test Circuit, Signal, and Timing Definition

PARAMETER MEASUREMENT INFORMATION (continued)

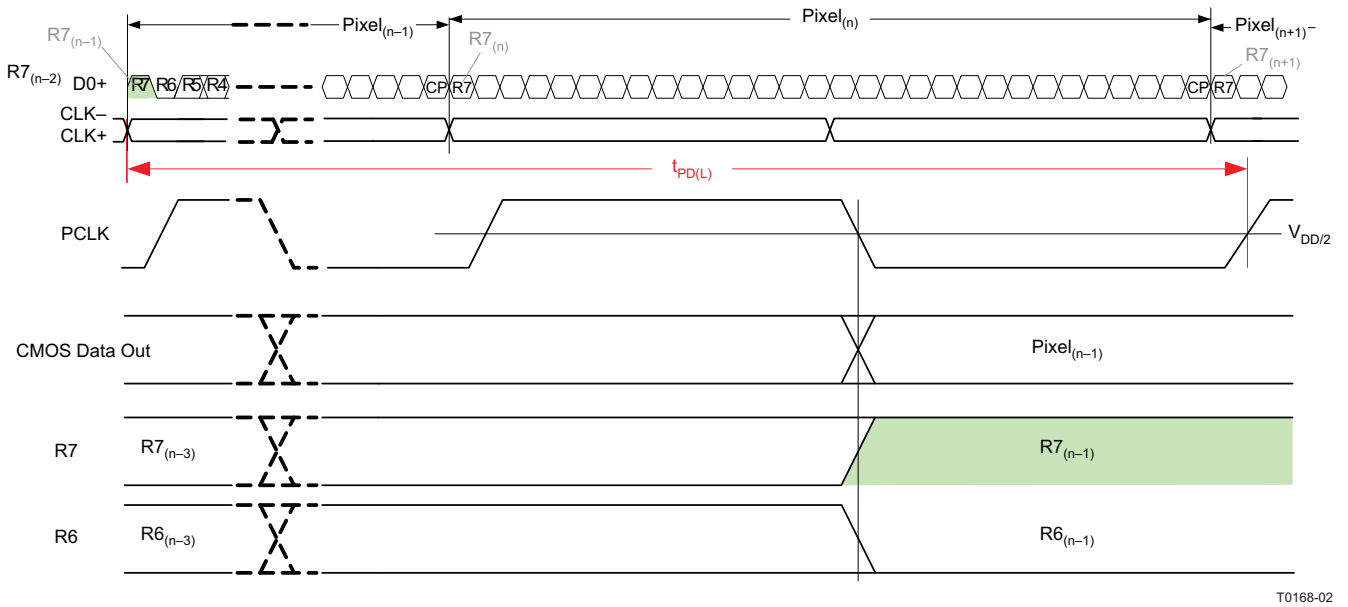

T0168-02

Figure 12. Propagation Delay, Input to Output

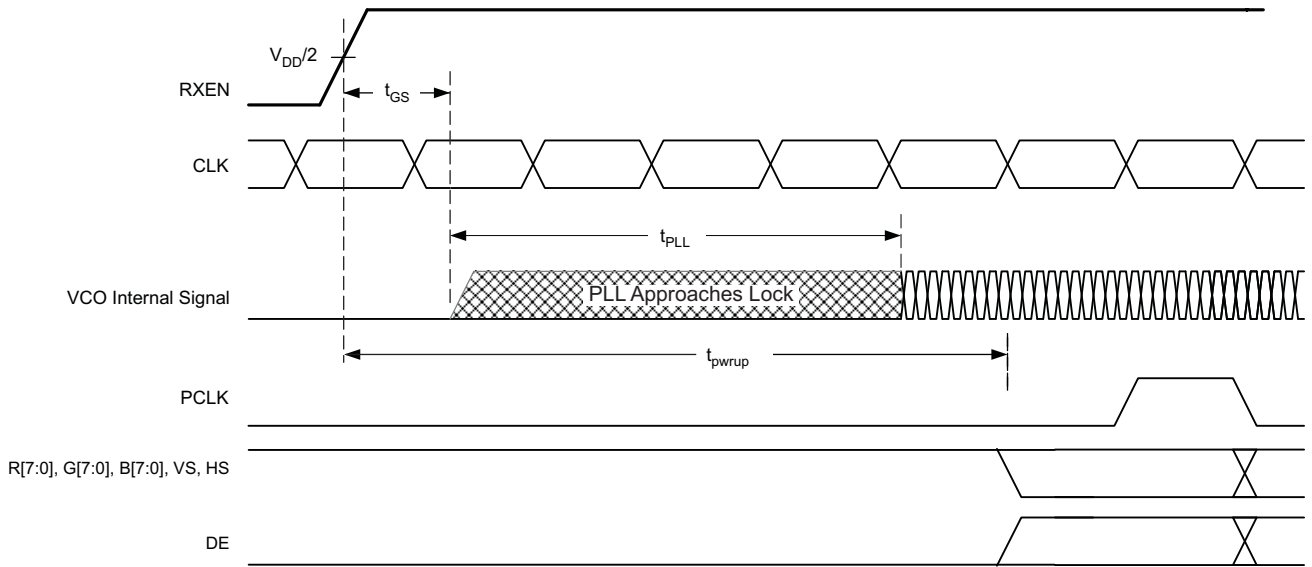

T0257-01

Figure 13. Receiver Phase-Locked Loop Set Time and Receiver Enable Time

PARAMETER MEASUREMENT INFORMATION (continued)

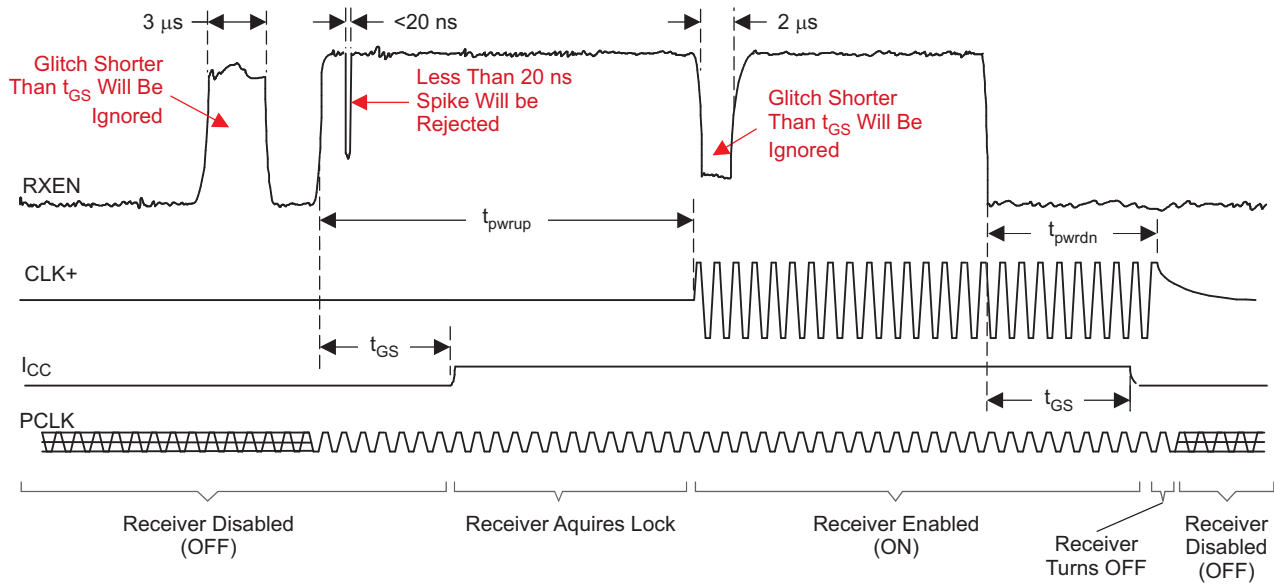

T0254-01

Figure 14. Receiver Enable/Disable Glitch Suppression Time

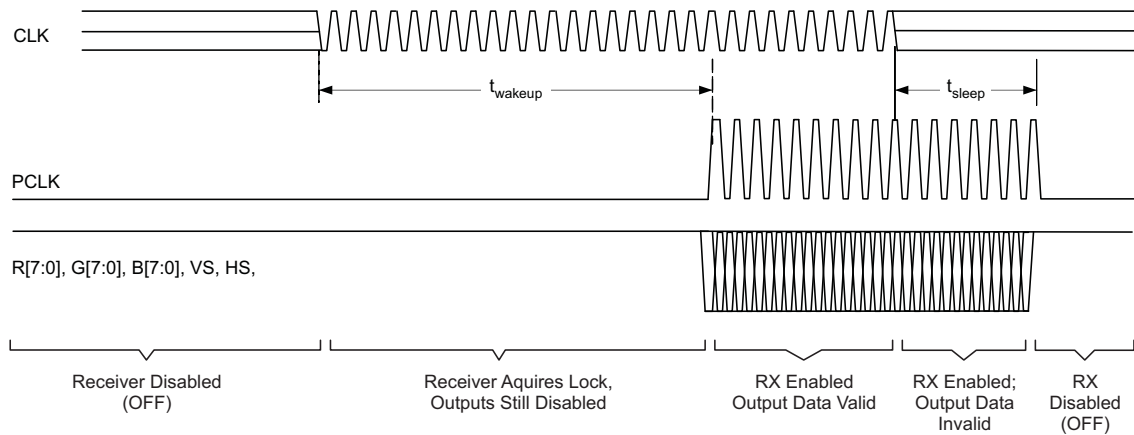

T0255-01

Figure 15. Standby Detection

PARAMETER MEASUREMENT INFORMATION (continued)

POWER CONSUMPTION TESTS

Table 5 shows an example test pattern word.

Table 5. Example Test Pattern Word

WORD	R[7:4], R[3:0], G[7:4], G[3:0], B[7:4], B[3:0], 0, VS, HS, DE
1	0x7C3E1E7

7				C				3				E				1				E				7			
R7	R6	R5	R4	R3	R2	R1	R0	G7	G6	G5	G4	G3	G2	G1	G0	B7	B6	B5	B4	B3	B2	B1	B0	0	VS	HS	DE
0	1	1	1	1	1	0	0	0	0	1	1	1	1	1	0	0	0	0	1	1	1	1	0	0	1	1	1

TYPICAL IC POWER-CONSUMPTION TEST PATTERN

Typical power-consumption test patterns consist of eight 30-bit transmit words. The pattern repeats itself throughout the entire measurement. It is assumed that every possible transmit code on RGB inputs has the same probability to occur during typical device operation.

Table 6. Typical IC Power-Consumption Test Pattern

WORD	TEST PATTERN: R[7:4], R[3:0], G[7:4], G[3:0], B[7:4], B[3:0], 0, VS, HS, DE
1	0x0000001
2	0x03F03F1
3	0xBF0BFF1
4	0x1D71D71
5	0x4C74C71
6	0xC45C451
7	0xA3aA3A5
8	0x5555553

MAXIMUM POWER-CONSUMPTION TEST PATTERN

The maximum (or worst-case) power consumption of the SN65LVDS308 is tested using the two different test patterns shown in Table 7. Test patterns consist of eight 30-bit transmit words. The pattern repeats itself throughout the entire measurement. It is assumed that every possible transmit code on the RGB inputs has the same probability to occur during typical device operation.

**Table 7. Worst-Case Power-Consumption
Test Pattern 1**

WORD	TEST PATTERN: R[7:4], R[3:0], G[7:4], G[3:0], B[7:4], B[3:0], 0, VS, HS, DE
1	0x0000000
2	0xFFFFFFFF7

**Table 8. Worst-Case Power-Consumption
Test Pattern 2**

WORD	TEST PATTERN: R[7:4], R[3:0], G[7:4], G[3:0], B[7:4], B[3:0], 0, VS, HS, DE
1	0x0000000
2	0xFFFFFFFF7

OUTPUT SKEW PULSE POSITION and JITTER PERFORMANCE

The following test pattern is used to measure the output skew pulse position and the jitter performance of the SN65LVDS308. The jitter test pattern stresses the interconnect, particularly to test for ISI, using very long run-lengths of consecutive bits, and incorporating very high and low data rates, maximizing switching noise. The pattern is self-repeating for the duration of the test.

Table 9. Transmit Jitter Test Pattern

WORD	TEST PATTERN: R[7:4], R[3:0], G[7:4], G[3:0], B[7:4], B[3:0], 0, VS, HS, DE
1	0x0000001
2	0x000FFF3
3	0x8008001
4	0x0030037
5	0xE00E001
6	0x00FF001
7	0x007E001
8	0x003C001
9	0x0018001
10	0x1C7E381
11	0x3333331
12	0x555AAA5
13	0x6DBDB61
14	0x7777771
15	0x555AAA3
16	0xAAAAAA5
17	0x5555553
18	0xAAA5555
19	0x8888881
20	0x9242491
21	0xAAA5571
22	0xCCCCCC1
23	0xE3E1C71
24	0xFFE7FF1
25	0xFFC3FF1
26	0xFF81FF1
27	0xFE00FF1
28	0x1FF1FF1
29	0xFFCFFC3
30	0x7FF7FF1
31	0xFFF0007
32	0xFFFFFFFF1

TYPICAL CHARACTERISTIC CURVES

Some of the plots in this section show more than one curve representing various device pin relationships. Taken together, they represent a working range for the tested parameter.

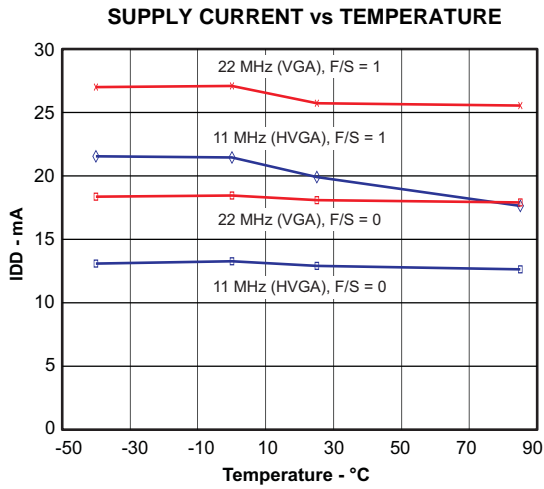

Figure 16.

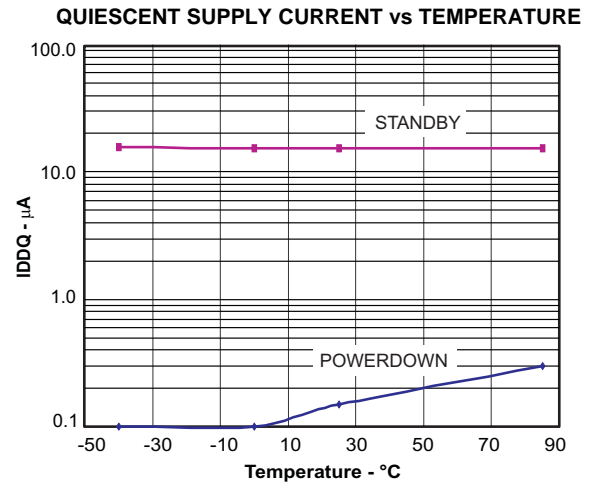

Figure 17.

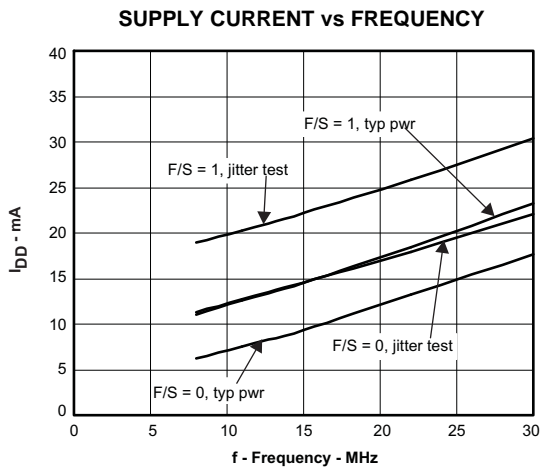

Figure 18.

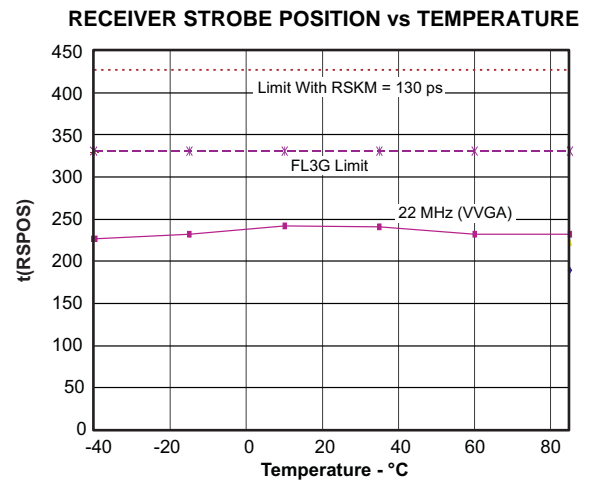

Figure 19.

TYPICAL CHARACTERISTIC CURVES (continued)

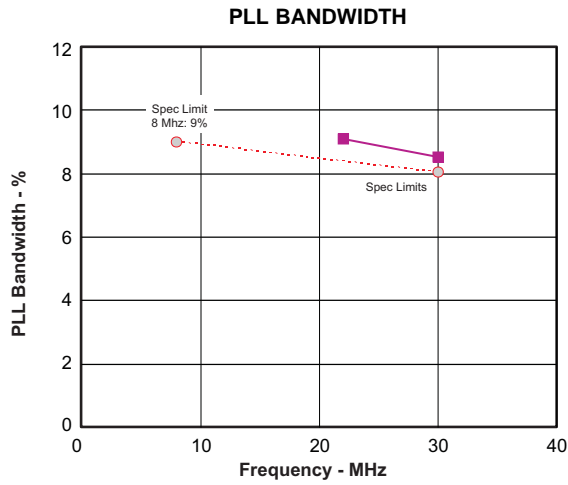

Figure 20.

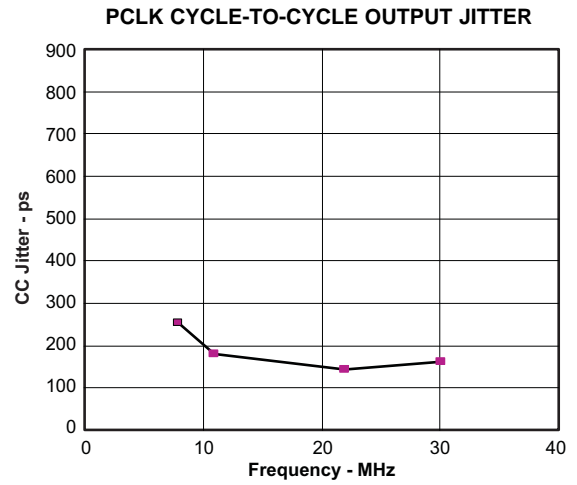

Figure 21.

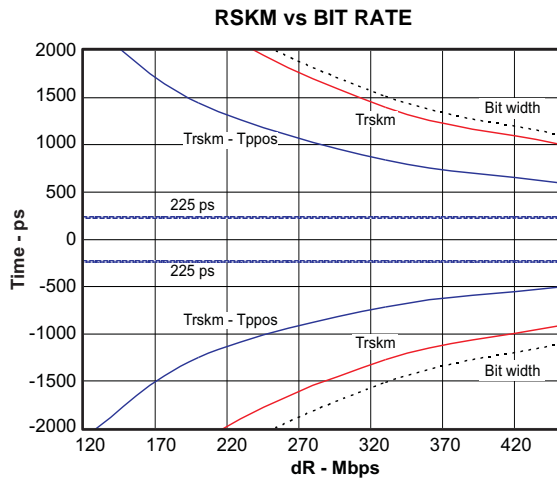

Figure 22.

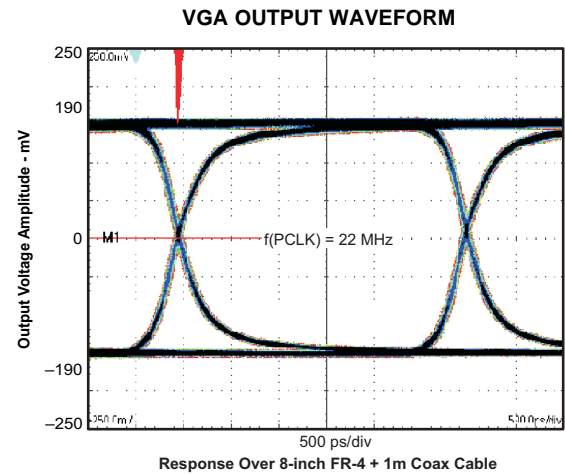

Figure 23.

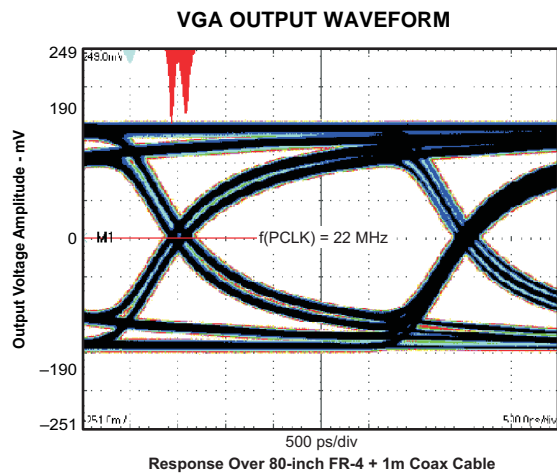

Figure 24.

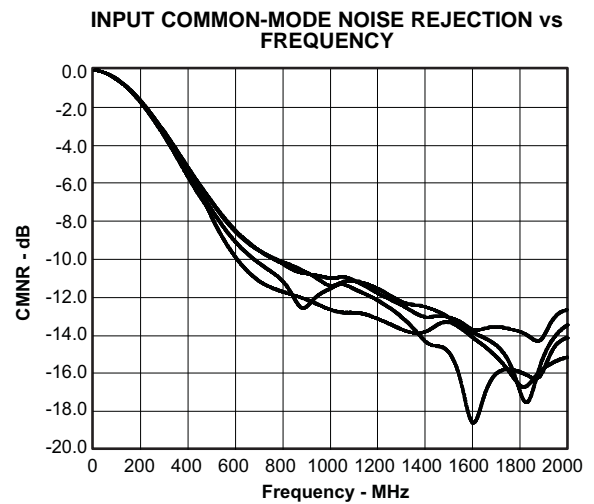

Figure 25.

TYPICAL CHARACTERISTIC CURVES (continued)

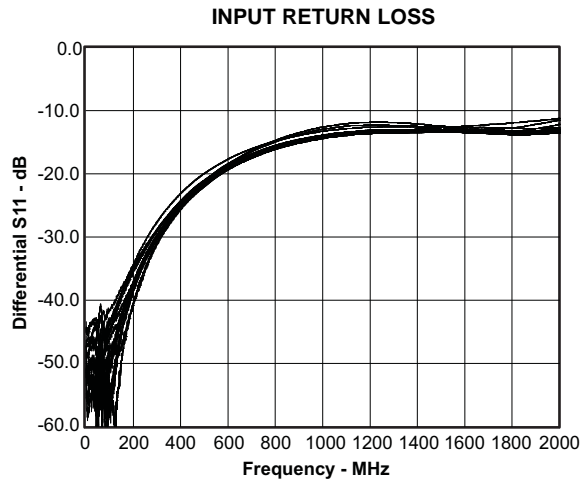

Figure 26.

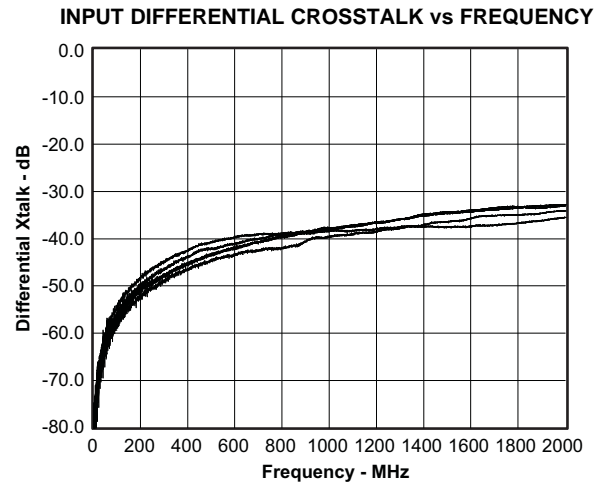

Figure 27.

APPLICATION INFORMATION

PREVENTING INCREASED LEAKAGE CURRENTS IN CONTROL INPUTS

A floating (left open) CMOS input allows leakage currents to flow from VDD to GND. Do not leave any CMOS input unconnected or floating. Every input must be connected to a valid logic level, V_{IH} or V_{IL} , while power is supplied to VDD. This also minimizes the power consumption of standby and power-down modes.

POWER-SUPPLY DESIGN RECOMMENDATION

For a multilayer PCB, it is recommended to keep one common GND layer underneath the device and connect all ground terminals directly to this plane.

SN65LVDS308 DECOUPLING RECOMMENDATION

The SN65LVDS308 was designed to operate reliably in a constricted environment with other digital switching ICs. In cell phone designs, the SN65LVDS308 often shares a power supply with various other ICs. The SN65LVDS308 can operate with power-supply noise as specified in the [Recommended Operating Conditions](#). To minimize the power-supply noise floor, provide good decoupling near the SN65LVDS308 power pins. The use of four ceramic capacitors (two 0.01- μF and two 0.1- μF) provides good performance. At the very least, it is recommended to install one 0.1- μF and one 0.01- μF capacitor near the SN65LVDS308. To avoid large current loops and trace inductance, the trace length between the decoupling capacitors and IC power input pins must be minimized. Placing the capacitor underneath the SN65LVDS308 on the bottom of the PCB is often a good choice.

VGA APPLICATION

Figure 28 shows a possible implementation of a standard 640×480 VGA display. The SN65LVDS307 interfaces to the SN65LVDS308, which is the corresponding receiver device, to deserialize the data and drive the display driver. The pixel clock rate of 22 MHz assumes $\sim 10\%$ blanking overhead and 60-Hz display refresh rate. The application assumes 24-bit color resolution. Also shown is how the application processor provides a power-down (reset) signal for both the serializer and the display driver. The signal count over the flexible printed circuit board (FPC) could be further decreased by using the standby detection feature of the SN65LVDS307 and SN65LVDS308 and pulling RXEN high.

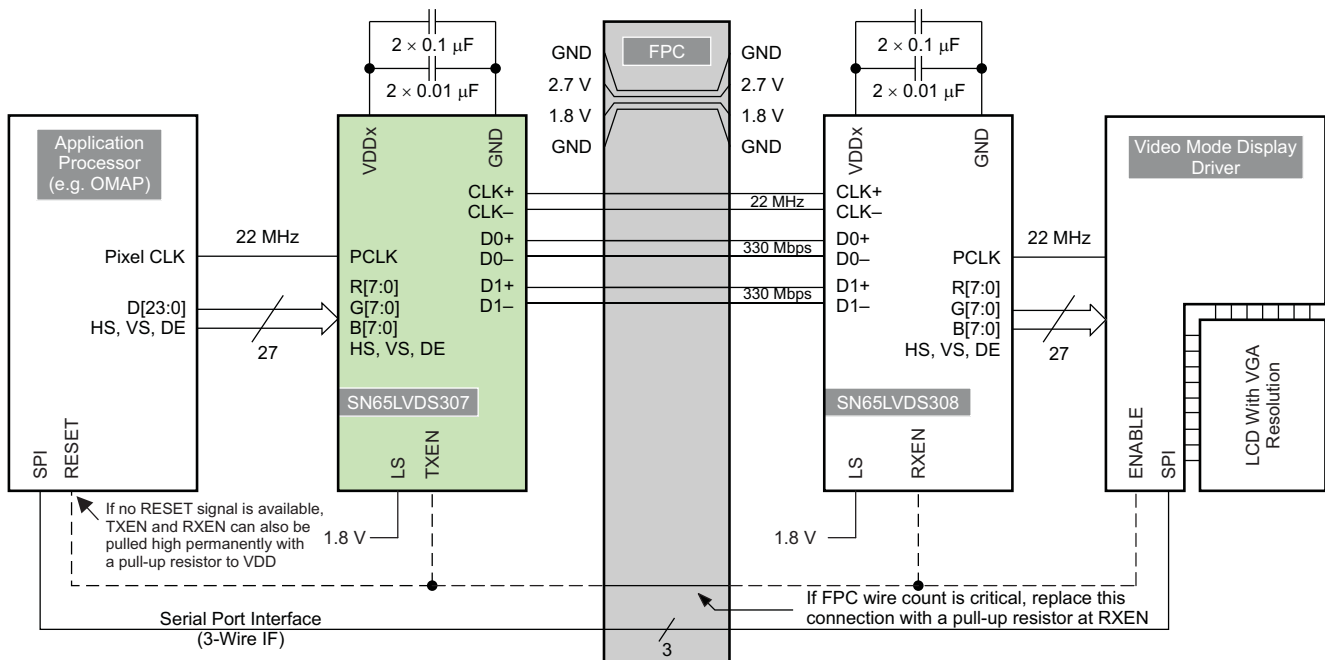

B0178-03

Figure 28. Typical VGA Display Application

APPLICATION INFORMATION (continued)

TYPICAL APPLICATION FREQUENCIES

The SN65LVDS308 supports pixel clock frequencies from 8 MHz to 30 MHz over two data pairs. [Table 10](#) provides a few typical display resolution examples and shows the number of data pairs necessary to connect the SN65LVDS308 with the display. The blanking overhead is assumed to be 20%. Often, blanking overhead is smaller, resulting in a lower data rate. Furthermore, the examples in the table assumes a display frame refresh rate of 60 Hz. The actual refresh rate may differ, depending on the application-processor clock implementation.

Table 10. Typical Application Data Rates and Serial Pair Usage

Display Screen Resolution	Visible Pixel Count	Blanking Overhead	Display Refresh Rate [Hz]	Pixel Clock Frequency [MHz]	Data Rate on D0 and D1 [Mbps]
240 × 320 (QVGA)	76,800	20%	90	8.3	124
640 × 200	128,000		60	9.2	138
352 × 416 (CIF+)	146,432			10.5	158
352 × 440	154,880			11.2	167
320 × 480 (HVGA)	153,600			11.1	166
800 × 250	200,000			14.4	216
640 × 320	204,800			14.7	221
640 × 480 (VGA)	307,200			30	11.1
640 × 480 (VGA)	307,200		60	22.1	332
1024 × 320	327,680			23.6	354
854 × 480 (WVGA)	409,920			29.5	443
800 × 600 (SVGA)	480,000		30	17.3	259
1024 × 768 (XGA)	786,432			28.3	425

CALCULATION EXAMPLE: HVGA DISPLAY

The following calculation shows an example for a half-VGA display with the following parameters:

Display resolution:	480 × 320
Frame refresh rate:	58.4 Hz
Vertical visible pixels:	320 lines
Vertical front porch:	10 lines
Vertical sync:	5 lines
Vertical back porch:	3 lines
Horizontal visible pixels:	480 columns
Horizontal front porch:	20 columns
Horizontal sync:	5 columns
Horizontal back porch:	3 columns

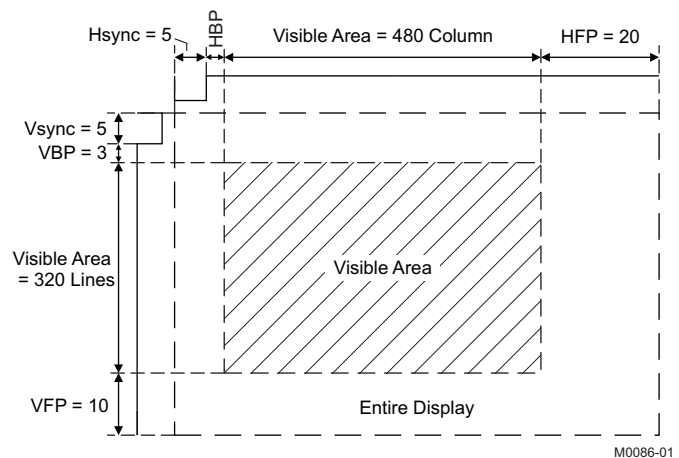

Figure 29. HVGA Display

Calculation of the total number of pixels and blanking overhead:

Visible area pixel count:	$480 \times 320 = 153,600$ pixels
Total frame pixel count:	$(320 + 10 + 5 + 3) \times (480 + 20 + 5 + 3) = 171,704$ pixels
Blanking overhead:	$(171,704 - 153,600) \div 153,600 \approx 11.8\%$

The application requires the following serial-link parameters:

Pixel clock frequency:	$171,704 \times 58.4 \text{ Hz} = 10 \text{ MHz}$
Serial data rate:	$10 \text{ MHz} \times 15 \text{ bits/channel} = 150 \text{ Mbps}$

HOW TO DETERMINE INTERCONNECT SKEW AND JITTER BUDGET

Designing a reliable data link requires examining the interconnect skew and jitter budget. The sum of all transmitter, PCB, connector, FPC, and receiver uncertainties must be smaller than the available serial bit time. The highest pixel clock frequency defines the available serial bit time. The transmitter timing uncertainty is defined by t_{PPOS} in the transmitter data sheet. For a bit-error-rate target of $\leq 10^{-12}$, the measurement duration for t_{PPOS} is $\geq 10^{12}$. The SN65LVDS308 receiver can tolerate a maximum timing uncertainty defined by t_{RSKM} . The interconnect budget is calculated by:

$$t_{interconnect} = t_{RSKM} - t_{PPOS}$$

Example:

$f_{PCLK}(\text{max}) = 23 \text{ MHz}$ (VGA display resolution, 60 Hz)

Transmission mode: 2-ChM; $t_{PPOS}(\text{SN65LVDS307}) = 330 \text{ ps}$

Target bit error rate: 10^{-12}

$t_{RSKM}(\text{SN65LVDS308}) = 1/(2 \times 15 \times f_{PCLK}) - 480 \text{ ps} = 969 \text{ ps}$

The interconnect budget for cable skew and ISI must be smaller than:

$$t_{interconnect} = t_{RSKM} - t_{PPOS} = 639 \text{ ps}$$

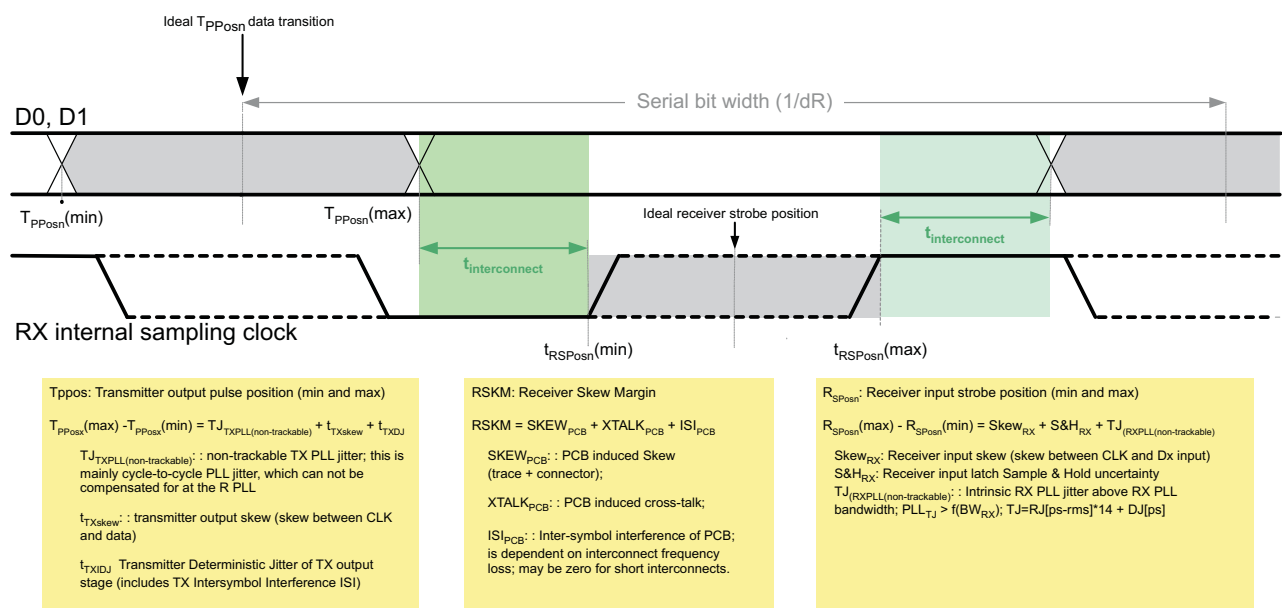

T0165-03

Figure 30. Jitter Budget

F/S-PIN SETTING AND CONNECTING THE SN65LVDS308 TO AN LCD DRIVER

NOTE:

Receiver PLL tracking: To maximize the design margin for the interconnect, good RX PLL tracking of the TX PLL is important. FlatLink3G requires the RX PLL to have a bandwidth higher than the bandwidth of the TX PLL. The SN65LVDS308 PLL design is optimized to track the SN65LVDS307 PLL particularly well, thus providing a very large receiver skew margin. A FlatLink3G-compliant link must provide at least ± 225 ppm of receiver skew margin for the interconnect.

It is important to understand the tradeoff between power consumption, EMI, and maximum speed when selecting the F/S signal. It is beneficial to choose the slowest rise time possible to minimize EMI and power consumption. Unfortunately, a slower rise time also reduces the timing margin left for the LCD driver. Hence, it is necessary to calculate the timing margin to select the correct F/S pin setting.

The output rise time depends on the output driver strength and the output load. An LCD driver typical capacitive load is assumed with ~ 10 pF. The higher the capacitive load, the slower is the rise time. Rise time of the SN65LVDS308 is measured as the time duration it takes the output voltage to rise from 20% of VDD to 80% of VDD, and fall time is defined as the time for the output voltage to transition from 80% of VDD down to 20% of VDD.

The rise time of the output stage is fixed and does not adjust to the pixel frequency. Only setting F/S changes the output rise time. Due to the short bit time at very fast pixel clock speeds and the real capacitive load of the display driver, the output amplitude might not reach VDD and GND saturation fully. To ensure sufficient signal swing and verify the design margin, it becomes necessary to determine that the output amplitude under any circumstance reaches the display driver's input stage logic threshold (usually 30% and 70% of VDD).

Figure 31 shows a worst-case rise time simulation assuming an LCD driver load of 16 pF at VGA display resolution. PCLK is the fastest-switching output. With F/S set to GND (Figure 31-b), the PCLK output voltage amplitude is significantly reduced. The voltage amplitude of the output data RGB[7:0], VS, HS, and DE shows less amplitude attenuation because these outputs carry random data patterns and toggle at half of the PCLK frequency or less. It is necessary to determine the timing margin between the SN65LVDS308 output and LCD driver input.

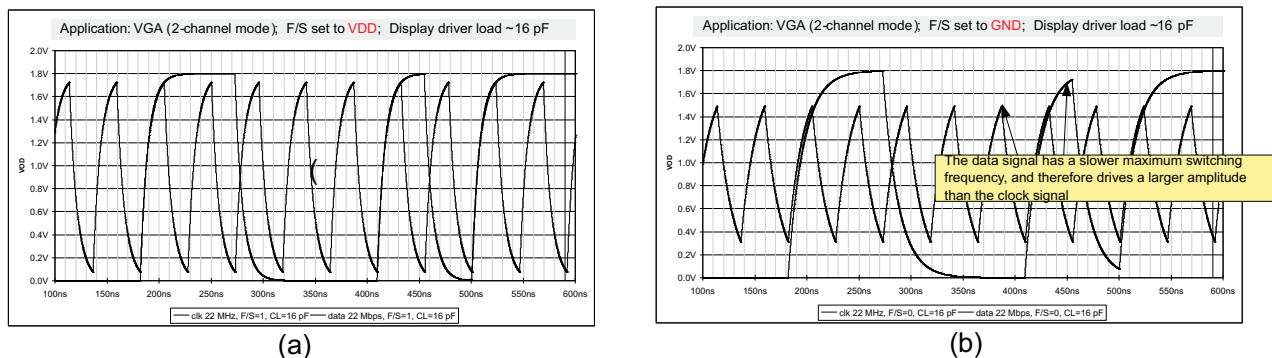

Figure 31. Output Amplitude as a Function of Output Toggling Frequency, Capacitive Load, and F/S Setting

HOW TO DETERMINE THE LCD DRIVER TIMING MARGIN

To determine the timing margin, it is necessary to specify the frequency of operation, identify the setup and hold times of the LCD driver, and specify the output load of the SN65LVDS308 as a combination of the LCD driver input parasitics plus any capacitance caused by the connecting PCB trace. Furthermore, the setting of pin F/S and the SN65LVDS308 output skew impact the margin. The total remaining design margin calculates as follows:

$$t_{DM} = \frac{1}{2 \times f_{PCLK}} - t_{DUTP(max_error)} - \frac{t_{rise(max)} \times C_{LOAD}}{10 \text{ pF}} - |t_{OSK}| \quad (3)$$

where:

- t_{DM} – Design margin
- f_{PCLK} – Pixel clock frequency
- $t_{DUTP(max_error)}$ – maximum duty cycle error
- $t_{rise(max)}$ – maximum rise or fall time; see $t_{r/f}$ under switching characteristics
- C_{LOAD} – parasitic capacitance (sum of LCD driver input parasitics + connecting PCB trace)
- t_{skew} – clock to data output skew of the SN65LVDS308

Example:

At a pixel clock frequency of 11 MHz (HVGA), and an assumed LCD driver load of 15 pF, the remaining timing margin is:

$$t_{DUTP(max_error)} = \frac{|t_{DUTP(max)} - 50|}{100\%} \times t_{PCLK} = \frac{5\%}{100\%} \times \frac{1}{11 \text{ MHz}} = 4.5 \text{ ns}$$

$$t_{DM} = \frac{1}{2 \times 11 \text{ MHz}} - 4.5 \text{ ns} - \frac{16 \text{ ns}_{(F/S=GND)} \times 15 \text{ pF}}{10 \text{ pF}} - 500 \text{ ps} = 16 \text{ ns}$$

As long as the setup and hold times of the LCD driver are each less than 16 ns, the timing budget is met sufficiently.

PACKAGING INFORMATION

Orderable Device	Status (1)	Package Type	Package Drawing	Pins	Package Qty	Eco Plan (2)	Lead/Ball Finish (6)	MSL Peak Temp (3)	Op Temp (°C)	Device Marking (4/5)	Samples
SN65LVDS308ZQCR	ACTIVE	BGA MICROSTAR JUNIOR	ZQC	48	2500	Green (RoHS & no Sb/Br)	SNAGCU	Level-3-260C-168 HR	-40 to 85	LVDS308	Samples

(1) The marketing status values are defined as follows:

ACTIVE: Product device recommended for new designs.

LIFEBUY: TI has announced that the device will be discontinued, and a lifetime-buy period is in effect.

NRND: Not recommended for new designs. Device is in production to support existing customers, but TI does not recommend using this part in a new design.

PREVIEW: Device has been announced but is not in production. Samples may or may not be available.

OBsolete: TI has discontinued the production of the device.

(2) Eco Plan - The planned eco-friendly classification: Pb-Free (RoHS), Pb-Free (RoHS Exempt), or Green (RoHS & no Sb/Br) - please check <http://www.ti.com/productcontent> for the latest availability information and additional product content details.

TBD: The Pb-Free/Green conversion plan has not been defined.

Pb-Free (RoHS): TI's terms "Lead-Free" or "Pb-Free" mean semiconductor products that are compatible with the current RoHS requirements for all 6 substances, including the requirement that lead not exceed 0.1% by weight in homogeneous materials. Where designed to be soldered at high temperatures, TI Pb-Free products are suitable for use in specified lead-free processes.

Pb-Free (RoHS Exempt): This component has a RoHS exemption for either 1) lead-based flip-chip solder bumps used between the die and package, or 2) lead-based die adhesive used between the die and leadframe. The component is otherwise considered Pb-Free (RoHS compatible) as defined above.

Green (RoHS & no Sb/Br): TI defines "Green" to mean Pb-Free (RoHS compatible), and free of Bromine (Br) and Antimony (Sb) based flame retardants (Br or Sb do not exceed 0.1% by weight in homogeneous material)

(3) MSL, Peak Temp. - The Moisture Sensitivity Level rating according to the JEDEC industry standard classifications, and peak solder temperature.

(4) There may be additional marking, which relates to the logo, the lot trace code information, or the environmental category on the device.

(5) Multiple Device Markings will be inside parentheses. Only one Device Marking contained in parentheses and separated by a "~" will appear on a device. If a line is indented then it is a continuation of the previous line and the two combined represent the entire Device Marking for that device.

(6) Lead/Ball Finish - Orderable Devices may have multiple material finish options. Finish options are separated by a vertical ruled line. Lead/Ball Finish values may wrap to two lines if the finish value exceeds the maximum column width.

Important Information and Disclaimer: The information provided on this page represents TI's knowledge and belief as of the date that it is provided. TI bases its knowledge and belief on information provided by third parties, and makes no representation or warranty as to the accuracy of such information. Efforts are underway to better integrate information from third parties. TI has taken and continues to take reasonable steps to provide representative and accurate information but may not have conducted destructive testing or chemical analysis on incoming materials and chemicals. TI and TI suppliers consider certain information to be proprietary, and thus CAS numbers and other limited information may not be available for release.

In no event shall TI's liability arising out of such information exceed the total purchase price of the TI part(s) at issue in this document sold by TI to Customer on an annual basis.

TAPE AND REEL INFORMATION



QUADRANT ASSIGNMENTS FOR PIN 1 ORIENTATION IN TAPE



*All dimensions are nominal

Device	Package Type	Package Drawing	Pins	SPQ	Reel Diameter (mm)	Reel Width W1 (mm)	A0 (mm)	B0 (mm)	K0 (mm)	P1 (mm)	W (mm)	Pin1 Quadrant
SN65LVDS308ZQCR	BGA MICROSTAR JUNIOR	ZQC	48	2500	330.0	12.4	4.3	4.3	1.5	8.0	12.0	Q1

TAPE AND REEL BOX DIMENSIONS



*All dimensions are nominal

Device	Package Type	Package Drawing	Pins	SPQ	Length (mm)	Width (mm)	Height (mm)
SN65LVDS308ZQCR	BGA MICROSTAR JUNIOR	ZQC	48	2500	338.1	338.1	20.6

ZQC (S-PBGA-N48)

PLASTIC BALL GRID ARRAY

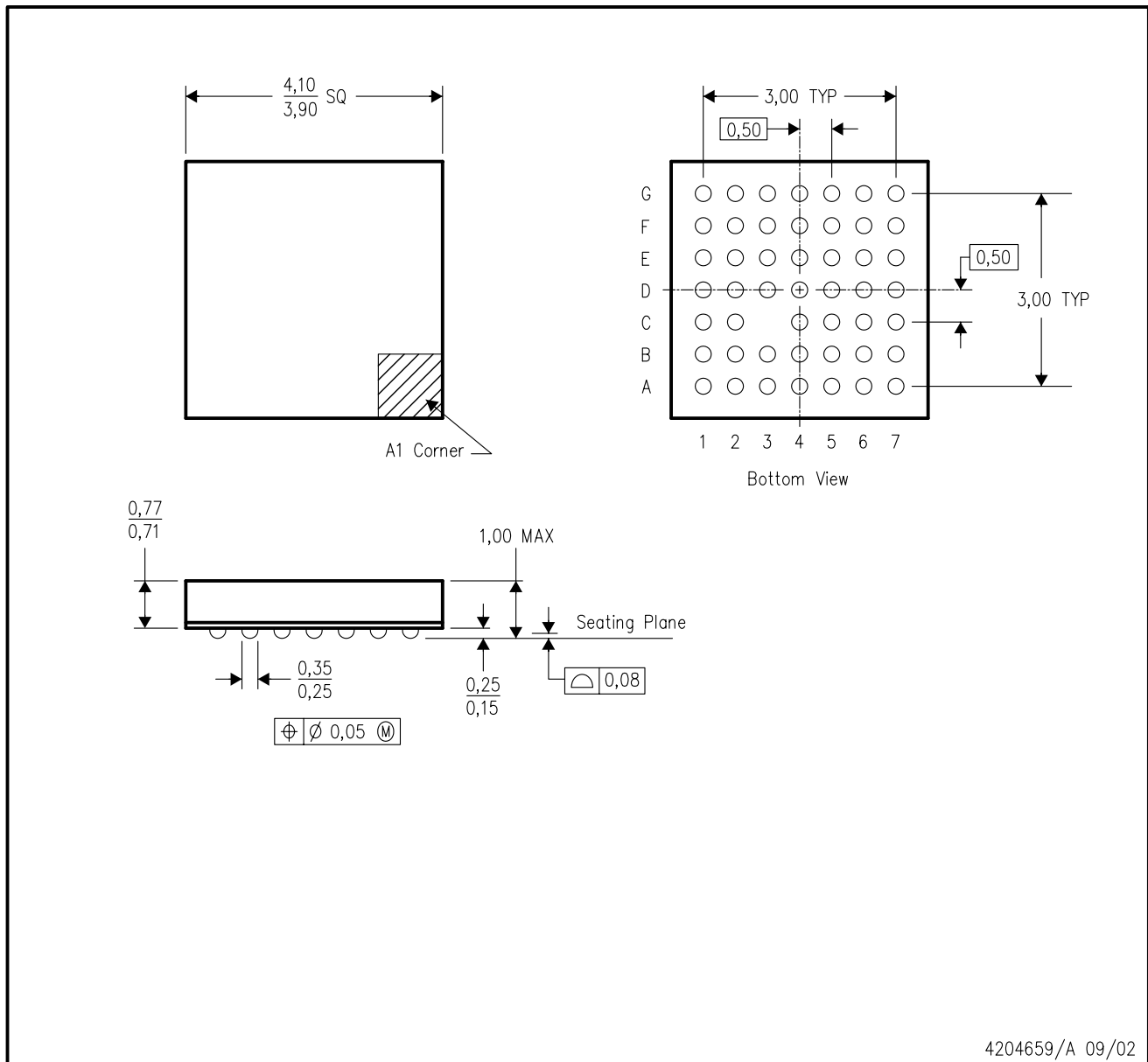

- NOTES:
- A. All linear dimensions are in millimeters.
 - B. This drawing is subject to change without notice.
 - C. MicroStar Junior™ BGA configuration
 - D. Falls within JEDEC MO-225
 - E. This package is lead-free.

MicroStar Junior is a trademark of Texas Instruments.

IMPORTANT NOTICE

Texas Instruments Incorporated and its subsidiaries (TI) reserve the right to make corrections, enhancements, improvements and other changes to its semiconductor products and services per JESD46, latest issue, and to discontinue any product or service per JESD48, latest issue. Buyers should obtain the latest relevant information before placing orders and should verify that such information is current and complete. All semiconductor products (also referred to herein as "components") are sold subject to TI's terms and conditions of sale supplied at the time of order acknowledgment.

TI warrants performance of its components to the specifications applicable at the time of sale, in accordance with the warranty in TI's terms and conditions of sale of semiconductor products. Testing and other quality control techniques are used to the extent TI deems necessary to support this warranty. Except where mandated by applicable law, testing of all parameters of each component is not necessarily performed.

TI assumes no liability for applications assistance or the design of Buyers' products. Buyers are responsible for their products and applications using TI components. To minimize the risks associated with Buyers' products and applications, Buyers should provide adequate design and operating safeguards.

TI does not warrant or represent that any license, either express or implied, is granted under any patent right, copyright, mask work right, or other intellectual property right relating to any combination, machine, or process in which TI components or services are used. Information published by TI regarding third-party products or services does not constitute a license to use such products or services or a warranty or endorsement thereof. Use of such information may require a license from a third party under the patents or other intellectual property of the third party, or a license from TI under the patents or other intellectual property of TI.

Reproduction of significant portions of TI information in TI data books or data sheets is permissible only if reproduction is without alteration and is accompanied by all associated warranties, conditions, limitations, and notices. TI is not responsible or liable for such altered documentation. Information of third parties may be subject to additional restrictions.

Resale of TI components or services with statements different from or beyond the parameters stated by TI for that component or service voids all express and any implied warranties for the associated TI component or service and is an unfair and deceptive business practice. TI is not responsible or liable for any such statements.

Buyer acknowledges and agrees that it is solely responsible for compliance with all legal, regulatory and safety-related requirements concerning its products, and any use of TI components in its applications, notwithstanding any applications-related information or support that may be provided by TI. Buyer represents and agrees that it has all the necessary expertise to create and implement safeguards which anticipate dangerous consequences of failures, monitor failures and their consequences, lessen the likelihood of failures that might cause harm and take appropriate remedial actions. Buyer will fully indemnify TI and its representatives against any damages arising out of the use of any TI components in safety-critical applications.

In some cases, TI components may be promoted specifically to facilitate safety-related applications. With such components, TI's goal is to help enable customers to design and create their own end-product solutions that meet applicable functional safety standards and requirements. Nonetheless, such components are subject to these terms.

No TI components are authorized for use in FDA Class III (or similar life-critical medical equipment) unless authorized officers of the parties have executed a special agreement specifically governing such use.

Only those TI components which TI has specifically designated as military grade or "enhanced plastic" are designed and intended for use in military/aerospace applications or environments. Buyer acknowledges and agrees that any military or aerospace use of TI components which have **not** been so designated is solely at the Buyer's risk, and that Buyer is solely responsible for compliance with all legal and regulatory requirements in connection with such use.

TI has specifically designated certain components as meeting ISO/TS16949 requirements, mainly for automotive use. In any case of use of non-designated products, TI will not be responsible for any failure to meet ISO/TS16949.

Products

Audio	www.ti.com/audio
Amplifiers	amplifier.ti.com
Data Converters	dataconverter.ti.com
DLP® Products	www.dlp.com
DSP	dsp.ti.com
Clocks and Timers	www.ti.com/clocks
Interface	interface.ti.com
Logic	logic.ti.com
Power Mgmt	power.ti.com
Microcontrollers	microcontroller.ti.com
RFID	www.ti-rfid.com
OMAP Applications Processors	www.ti.com/omap
Wireless Connectivity	www.ti.com/wirelessconnectivity

Applications

Automotive and Transportation	www.ti.com/automotive
Communications and Telecom	www.ti.com/communications
Computers and Peripherals	www.ti.com/computers
Consumer Electronics	www.ti.com/consumer-apps
Energy and Lighting	www.ti.com/energy
Industrial	www.ti.com/industrial
Medical	www.ti.com/medical
Security	www.ti.com/security
Space, Avionics and Defense	www.ti.com/space-avionics-defense
Video and Imaging	www.ti.com/video

TI E2E Community

e2e.ti.com