



QUAD CHANNEL M-LVDS RECEIVERS

Check for Samples: [SN65MLVD048](#)

FEATURES

- Low-Voltage Differential 30-Ω to 55-Ω Line Receivers for Signaling Rates⁽¹⁾ up to 250Mbps; Clock Frequencies up to 125MHz
- Type-1 Receiver Incorporates 25 mV of Input Threshold Hysteresis
- Type-2 Receiver Provides 100 mV Offset Threshold to Detect Open-Circuit and Idle-Bus Conditions
- Wide Receiver Input Common-Mode Voltage Range, -1 V to 3.4 V, Allows 2 V of Ground Noise
- Meets or Exceeds the M-LVDS Standard TIA/EIA-899 for Multipoint Topology
- High Input Impedance when $V_{CC} \leq 1.5V$
- Enhanced ESD Protection: 7 kV HBM on all pins
- 48-Pin 7 X 7 QFN (RGZ)

⁽¹⁾ The signaling rate of a line is the number of voltage transitions that are made per second, expressed in the units bps (bits per second).

APPLICATIONS

- Parallel Multipoint Data and Clock Transmission via Backplanes and Cables
- Cellular Base Stations
- Central Office Switches
- Network Switches and Routers

LOGIC DIAGRAM (POSITIVE LOGIC)

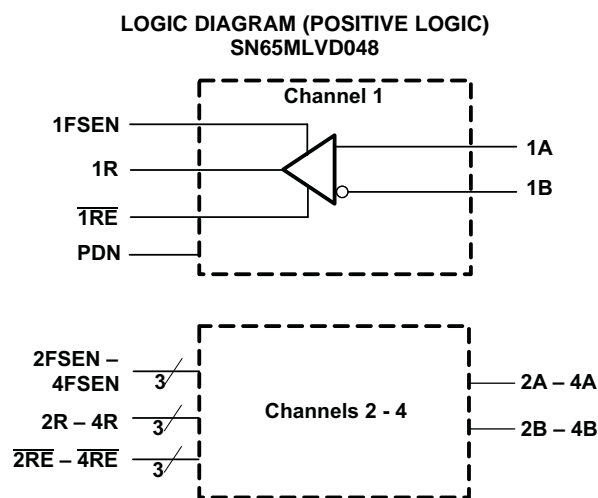

DESCRIPTION

The SN65MLVD048 is a quad-channel M-LVDS receiver. This device is designed in full compliance with the TIA/EIA-899 (M-LVDS) standard, which is optimized to operate at signaling rates up to 250 Mbps. Each receiver channel is controlled by a receive enable (\overline{RE}). When $\overline{RE} = \text{low}$, the corresponding channel is enabled; when $\overline{RE} = \text{high}$, the corresponding channel is disabled.

The M-LVDS standard defines two types of receivers, designated as Type-1 and Type-2. Type-1 receivers have thresholds centered about zero with 25 mV of hysteresis to prevent output oscillations with loss of input; Type-2 receivers implement a failsafe by using an offset threshold. Receiver outputs are slew rate controlled to reduce EMI and crosstalk effects associated with large current surges.

The devices are characterized for operation from -40°C to 85°C .



Please be aware that an important notice concerning availability, standard warranty, and use in critical applications of Texas Instruments semiconductor products and disclaimers thereto appears at the end of this data sheet.

PowerPAD is a trademark of Texas Instruments.

SN65MLVD048

SLLS903 – DECEMBER 2009

www.ti.com

These devices have limited built-in ESD protection. The leads should be shorted together or the device placed in conductive foam during storage or handling to prevent electrostatic damage to the MOS gates.

PIN FUNCTIONS

PIN		I/O	DESCRIPTION
NAME	NO.		
1R–4R	36, 33, 29, 26	O	Data output from receivers
1A–4A	47, 3, 9, 13	I/O	M-LVDS bus non-inverting input/output
1B–4B	48, 4, 10, 14	I/O	M-LVDS bus inverting input/output
GND	6, 7, 18, 23, 27, 31, 34, 38, 43	I	Circuit ground. ALL GND pins must be connected to ground.
V _{CC}	2, 11, 15, 16, 24, 37, 45, 46	I	Supply voltage. ALL VCC pins must be connected to supply.
$\overline{1RE-4RE}$	40, 42, 19, 21	I	Receiver enable, active low, enables individual receivers. When this pin is left floating, internally this pin will be pulled to logic HIGH.
1FSEN–4FSEN	39, 41, 20, 22	I	Failsafe enable pin. When this pin is left floating, internally this pin will be pulled to logic HIGH. This pin enables the Type 2 receiver for the respective channel. xFSEN = L → Type 1 receiver inputs xFSEN = H → Type 2 receiver inputs
PDN	30		Power Down pin. When this pin is left floating, internally this pin will be pulled to logic LOW. When PDN is HIGH, the device is powered up. When PDN is LOW, the device overrides all other control and powers down. All outputs are Hi-Z
NC	1, 5, 8, 12, 17, 25, 28, 32, 35		Not Connected
NC	44		Not Connected. Internal TI Test pin. This pin must be left unconnected.
PowerPAD™	–		Connected to GND

RGZ PACKAGE (TOP VIEW)

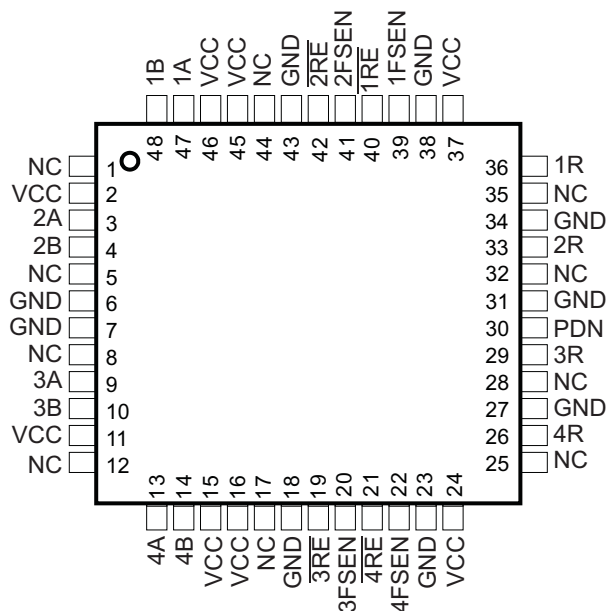

Table 1. DEVICE FUNCTION TABLE

INPUTS ⁽¹⁾				RECEIVER TYPE	OUTPUT ⁽¹⁾
$V_{ID} = V_A - V_B$	PDN	FSEN	\overline{RE}		R
$V_{ID} > 35 \text{ mV}$	H	L	L	Type 1	H
$-35 \text{ mV} \leq V_{ID} \leq 35 \text{ mV}$	H	L	L	Type 1	?
$V_{ID} < -35 \text{ mV}$	H	L	L	Type 1	L
$V_{ID} > 135 \text{ mV}$	H	H	L	Type 2	H
$65 \text{ mV} \leq V_{ID} \leq 135 \text{ mV}$	H	H	L	Type 2	?
$V_{ID} < 65 \text{ mV}$	H	H	L	Type 2	L
Open Circuit	H	L	L	Type 1	?
Open Circuit	H	H	L	Type 2	L
X	H	X	H	X	Z
X	H	X	OPEN	X	Z
X	L	X	X	X	Z

(1) H=high level, L=low level, Z=high impedance, X=Don't care, ?=indeterminate

ORDERING INFORMATION⁽¹⁾

PART NUMBER	FUNCTION	PART MARKING	PACKAGE / CARRIER
SN65MLVD048RGZR	M-LVDS Type 1 and 2 Receiver	MLVD048	48-Pin QFN / Tape and Reel
SN65MLVD048RGZT		MLVD048	48-Pin QFN / Small Tape and Reel

(1) For the most current package and ordering information, see the Package Option Addendum at the end of this document, or see the TI website at www.ti.com.

PACKAGE DISSIPATION RATINGS⁽¹⁾

PACKAGE	PCB TYPE	$T_A \leq 25^\circ\text{C}$ POWER RATING	DERATING FACTOR ⁽²⁾ ABOVE $T_A = 25^\circ\text{C}$	$T_A = 85^\circ\text{C}$ POWER RATING
48-Pin QFN (RGZ)	Low-K	1298 mW	12.98 mW/°C	519 mW
	High-K	3448 mW	34.48 mW/°C	1379 mW

(1) The thermal dissipations are in the consideration of soldering down the powerPAD without via on each type of boards.

(2) This is the inverse of the junction-to-ambient thermal resistance when board-mounted and with no air flow.

THERMAL CHARACTERISTICS

PARAMETER		TEST CONDITIONS	MIN	TYP	MAX	UNIT
$R_{\theta JB}$	Junction-to-board thermal resistance			9		°C/W
$R_{\theta JC}$	Junction-to-case thermal resistance			20		°C/W
$R_{\theta JP}$	Junction-to-pad thermal resistance			1.37		°C/W
P_D	Device power dissipation	\overline{RE} at 0 V, $C_L = 15 \text{ pF}$, $V_{ID} = 400 \text{ mV}$, 125 MHz			339	mW

ABSOLUTE MAXIMUM RATINGS

 over operating free-air temperature range (unless otherwise noted) ⁽¹⁾

		VALUE	UNIT
V _{CC}	Supply voltage range ⁽²⁾	–0.5 to 4	V
	Input voltage range	\overline{RE} , FSEN	–0.5 to 4
		A or B	–1.8 to 4
	Output voltage range	R	–0.3 to 4
	Electrostatic discharge	Human-body model ⁽³⁾	All other pins
		Charged-device model ⁽⁴⁾	All pins

- (1) Stresses beyond those listed under *absolute maximum ratings* may cause permanent damage to the device. These are stress ratings only, and functional operation of the device at these or any other conditions beyond those indicated under *recommended operating conditions* is not implied. Exposure to absolute-maximum-rated conditions for extended periods may affect device reliability.
- (2) All voltage values, except differential I/O bus voltages, are with respect to network ground terminal.
- (3) Tested in accordance with JEDEC Standard 22, Test Method A114-E. Bus pin stressed with respect to a common connection of GND and V_{CC}.
- (4) Tested in accordance with EIA-JEDEC JESD22-C101D.

RECOMMENDED OPERATING CONDITIONS

over operating free-air temperature range (unless otherwise noted)

		MIN	NOM	MAX	UNIT
V _{CC}	Supply voltage	3	3.3	3.6	V
V _{IH}	High-level input voltage	2		V _{CC}	V
V _{IL}	Low-level input voltage	GND		0.8	V
V _A or V _B	Voltage at any bus terminal	–1.4		3.8	V
V _{ID}	Magnitude of differential input voltage	0.05		V _{CC}	V
V _{IC}	Differential common-mode input voltage	–1		3.4	V
R _L	Differential load resistance	30	50		Ω
1/t _{UI}	Signaling rate			250	Mbps
T _A	Operating free-air temperature	–40		85	°C

DEVICE ELECTRICAL CHARACTERISTICS

over recommended operating conditions (unless otherwise noted)

PARAMETER	TEST CONDITIONS	MIN	TYP ⁽¹⁾	MAX	UNIT
I _{CC}	Supply current		86	94	mA
	Power down		0.75	1.5	mA

- (1) All typical values are at 25°C and with a 3.3-V supply voltage.

RECEIVER ELECTRICAL CHARACTERISTICS

over recommended operating conditions (unless otherwise noted)

PARAMETER		TEST CONDITIONS	MIN	TYP ⁽¹⁾	MAX	UNIT	
V _{IT+}	Positive-going differential input voltage threshold	Type 1			35	mV	
		Type 2			135		
V _{IT-}	Negative-going differential input voltage threshold	Type 1	See Table 2 and Table 3		-35	mV	
		Type 2			65		
V _{HYS}	Differential input voltage hysteresis (V _{IT+} - V _{IT-})	Type 1			25	mV	
		Type 2			0		
V _{OH}	High-level output voltage	I _{OH} = -8 mA		2.4			V
V _{OL}	Low-level output voltage	I _{OL} = 8 mA				0.4	V
I _{IH}	High-level input current	V _{IH} = 2 V to V _{CC}	-10			μA	
I _{IL}	Low-level input current	V _{IL} = GND to 0.8 V	-10			μA	
I _{OZ}	High-impedance output current	V _O = 0 V or V _{CC}	-10		15	μA	
I _A or I _B	Receiver input current	One input (V _A or V _B) = -1.4 V or 3.8 V, Other input = 1.2 V	-20		20	μA	
I _{AB}	Receiver differential input current (I _A - I _B)	V _A = V _B = -1.4 V or 3.8 V	-4		4	μA	
I _{A(OFF)} or I _{B(OFF)}	Receiver input current	One input (V _A or V _B) = -1.4 V or 3.8 V, Other input = 1.2 V, V _{CC} = GND or 1.5 V	-32		32	μA	
I _{AB(OFF)}	Receiver power-off differential input current (I _A - I _B)	V _A = V _B = -1.4 V or 3.8 V, V _{CC} = GND or 1.5 V	-4		4	μA	
C _A or C _B	Input capacitance	V _I = 0.4sin(30E6πt) + 0.5V, ⁽²⁾ Other input at 1.2 V		5		pF	
C _{AB}	Differential input capacitance	V _{AB} = 0.4sin(30E6πt) + 0.5 V ⁽²⁾			3	pF	
C _{A/B}	Input capacitance balance, (C _A /C _B)		0.99		1.01		

(1) All typical values are at 25°C and with a 3.3-V supply voltage.

(2) HP4194A impedance analyzer (or equivalent)

RECEIVER SWITCHING CHARACTERISTICS

over recommended operating conditions (unless otherwise noted)

PARAMETER		TEST CONDITIONS	MIN	TYP ⁽¹⁾	MAX	UNIT	
t_{PLH}	Propagation delay time, low-to-high-level output	$C_L = 15$ pF, See Figure 2	2		6	ns	
t_{PHL}	Propagation delay time, high-to-low-level output		2		6	ns	
t_r	Output signal rise time		1		2.3		
t_f	Output signal fall time		1		2.3	ns	
$t_{sk(p)}$	Pulse skew ($ t_{PHL} - t_{PLH} $)		Type 1		35	270	ps
			Type 2		150	460	
$t_{sk(pp)}$	Part-to-part skew				800	ps	
$t_{jit(per)}$	Period jitter, rms (1 standard deviation) ⁽²⁾		All channels switching, 125 MHz clock input ⁽³⁾ , See Figure 4			6	ps
$t_{jit(c-c)}$	Cycle-to-cycle jitter, rms ⁽²⁾					13	ps
$t_{jit(det)}$	Deterministic jitter ⁽²⁾		Type 1			800	ps
		Type 2			945	ps	
$t_{jit(ran)}$	Random jitter ⁽²⁾	Type 1			9	ps	
		Type 2			8	ps	
t_{PZH}	Enable time, high-impedance-to-high-level output	$C_L = 15$ pF, See Figure 3			15	ns	
t_{PZL}	Enable time, high-impedance-to-low-level output	$C_L = 15$ pF, See Figure 3			15	ns	
t_{PHZ}	Disable time, high-level-to-high-impedance output	$C_L = 15$ pF, See Figure 3			10	ns	
t_{PLZ}	Disable time, low-level-to-high-impedance output	$C_L = 15$ pF, See Figure 3			10	ns	

(1) All typical values are at 25°C and with a 3.3-V supply voltage.

(2) Jitter is ensured by design and characterization. Stimulus jitter has been subtracted from the numbers.

 (3) $t_r = t_f = 0.5$ ns (10% to 90%)

EQUIVALENT INPUT AND OUTPUT SCHEMATIC DIAGRAMS

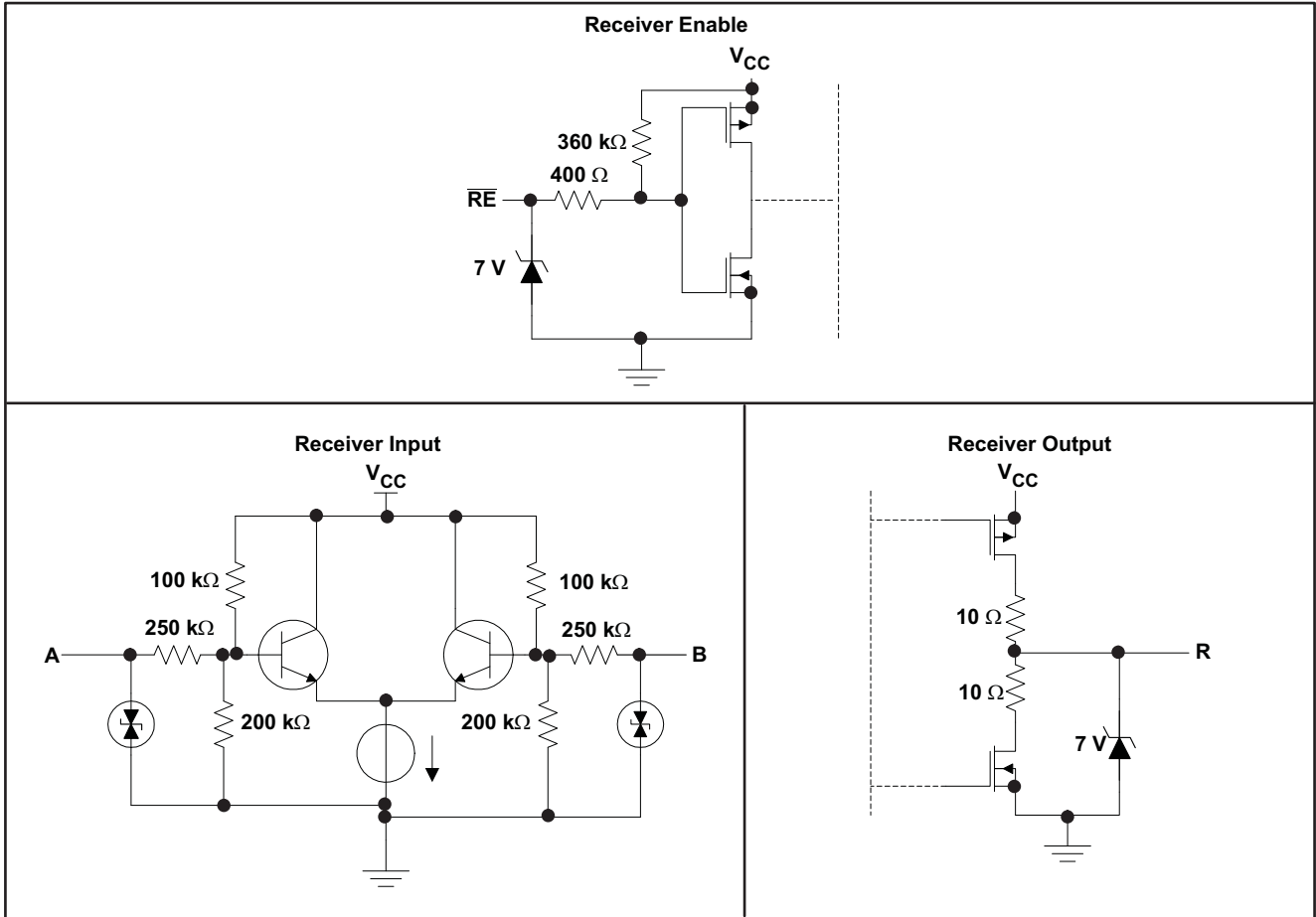

PARAMETER MEASUREMENT INFORMATION

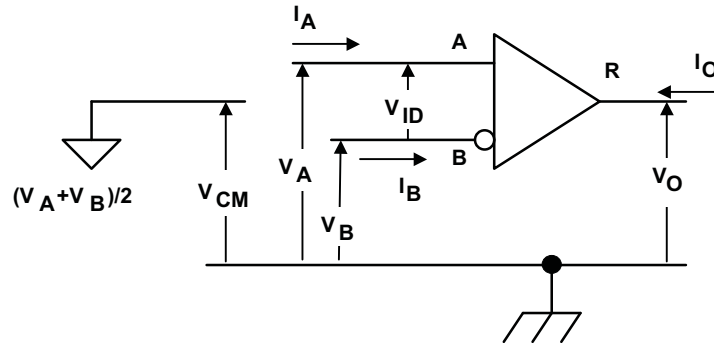

Figure 1. Receiver Voltage and Current Definitions

Table 2. Type-1 Receiver Input Threshold Test Voltages

APPLIED VOLTAGES		RESULTING DIFFERENTIAL INPUT VOLTAGE	RESULTING COMMON-MODE INPUT VOLTAGE	RECEIVER OUTPUT ⁽¹⁾
V_{IA}	V_{IB}	V_{ID}	V_{IC}	
2.400	0.000	2.400	1.200	H
0.000	2.400	-2.400	1.200	L
3.400	3.365	0.035	3.3825	H
3.365	3.400	-0.035	3.3825	L
-0.965	-1	0.035	-0.9825	H
-1	-0.965	-0.035	-0.9825	L

(1) H= high level, L = low level, output state assumes receiver is enabled ($\overline{RE} = L$)

Table 3. Type-2 Receiver Input Threshold Test Voltages

APPLIED VOLTAGES		RESULTING DIFFERENTIAL INPUT VOLTAGE	RESULTING COMMON-MODE INPUT VOLTAGE	RECEIVER OUTPUT ⁽¹⁾
V_{IA}	V_{IB}	V_{ID}	V_{IC}	
2.400	0.000	2.400	1.200	H
0.000	2.400	-2.400	1.200	L
3.400	3.265	0.135	3.3325	H
3.4000	3.335	0.05065	3.3675	L
-0.865	-1	0.135	-0.9325	H
-0.935	-1	0.065	-0.9675	L

(1) H= high level, L = low level, output state assumes receiver is enabled ($\overline{RE} = L$)

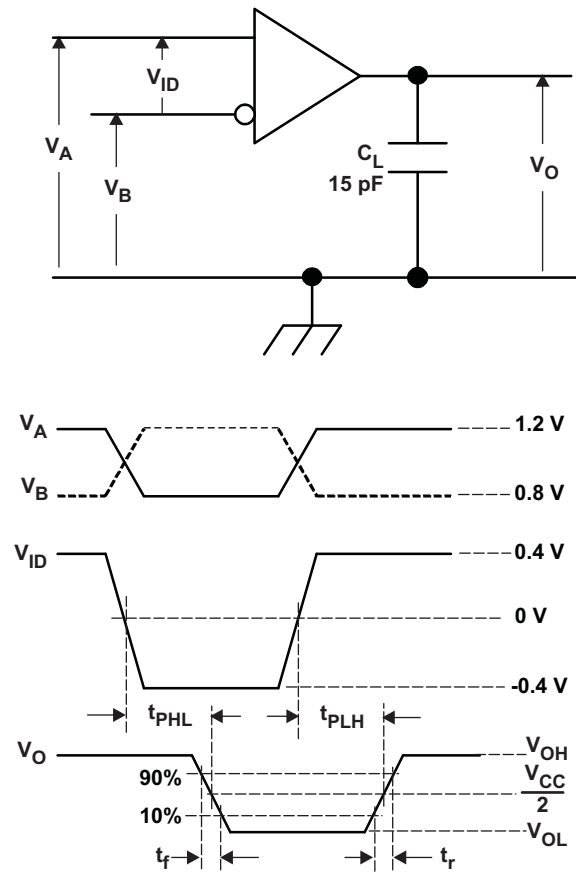

- A. All input pulses are supplied by a generator having the following characteristics: t_r or $t_f \leq 1$ ns, Frequency = 1 MHz, duty cycle = $50 \pm 5\%$. C_L is a combination of a 20%-tolerance, low-loss ceramic, surface-mount capacitor and fixture capacitance within 2 cm of the D.U.T.
- B. The measurement is made on test equipment with a -3dB bandwidth of at least 1 GHz.

Figure 2. Receiver Timing Test Circuit and Waveforms

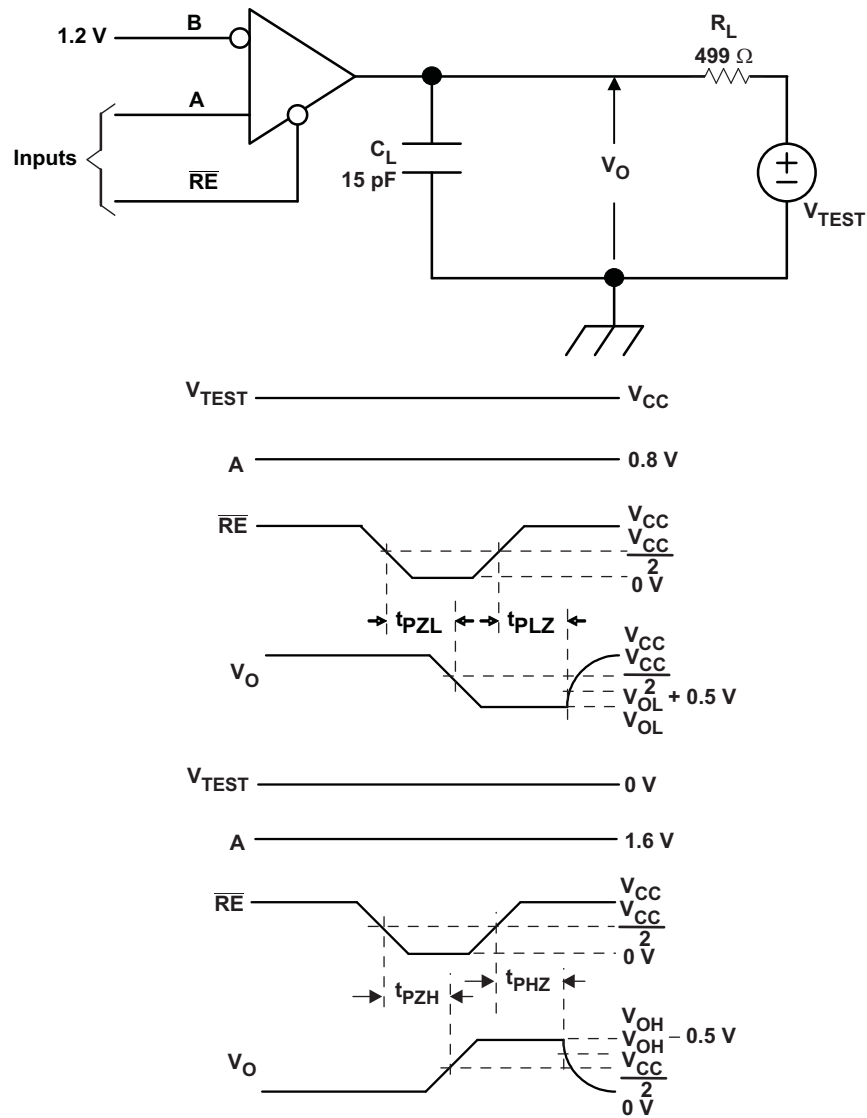

- A. All input pulses are supplied by a generator having the following characteristics: t_r or $t_f \leq 1$ ns, frequency = 1 MHz, duty cycle = $50 \pm 5\%$.
- B. R_L is 1% tolerance, metal film, surface mount, and located within 2 cm of the D.U.T
- C. C_L is the instrumentation and fixture capacitance within 2 cm of the D.U.T. and $\pm 20\%$. The measurement is made on test equipment with a -3 dB bandwidth of at least 1GHz.

Figure 3. Receiver Enable/Disable Time Test Circuit and Waveforms

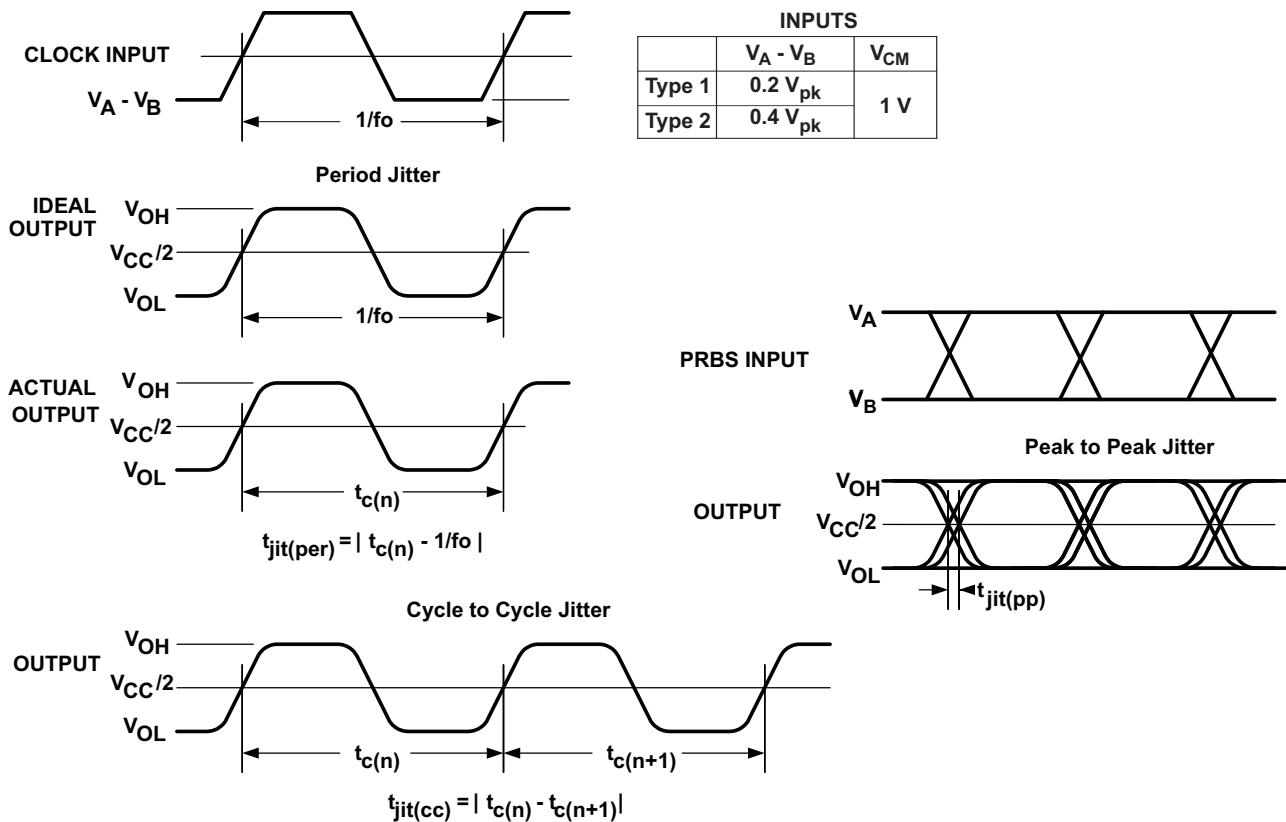

- A. All input pulses are supplied by the Agilent 81250 Parallel BERT Stimulus System with plug-in E4832A.
- B. The cycle-to-cycle jitter measurement is made on a TEK TDS6604 running TDSJIT3 application software.
- C. All other jitter measurements are made with an Agilent Infiniium DCA-J 86100C Digital Communications Analyzer.
- D. Period jitter and cycle-to-cycle jitter are measured using a 125-MHz 50 ± 1% duty cycle clock input. Measured over 75K samples.
- E. Deterministic jitter and random jitter are measured using a 250-Mbps 2¹⁵-1 PRBS input. Measured over BER = 10⁻¹²

Figure 4. Receiver Jitter Measurement Waveforms

TYPICAL CHARACTERISTICS

**SUPPLY CURRENT
vs
FREQUENCY**

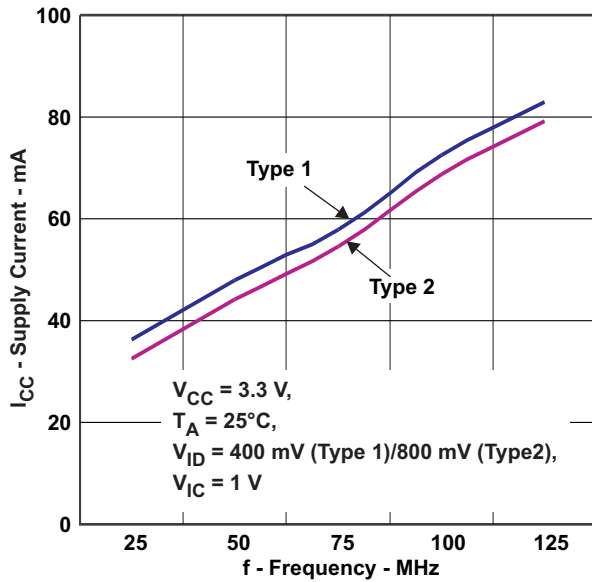

Figure 5.

**RECEIVER (TYPE-1) PROPAGATION DELAY TIME
vs
FREE-AIR TEMPERATURE**

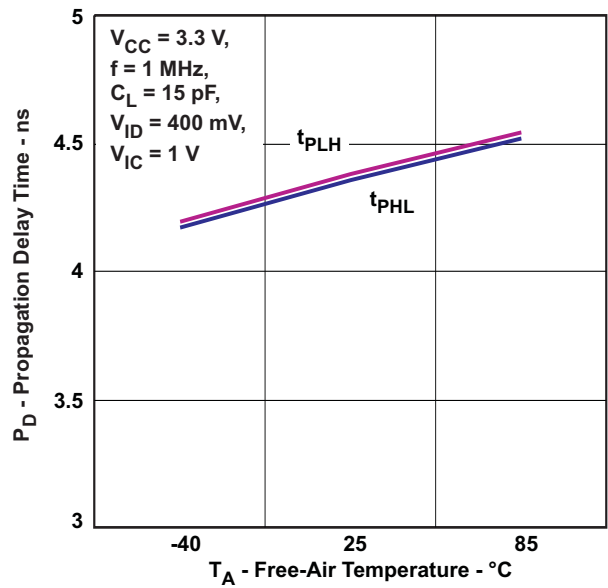

Figure 6.

**RECEIVER (TYPE-2) PROPAGATION DELAY TIME
vs
FREE-AIR TEMPERATURE**

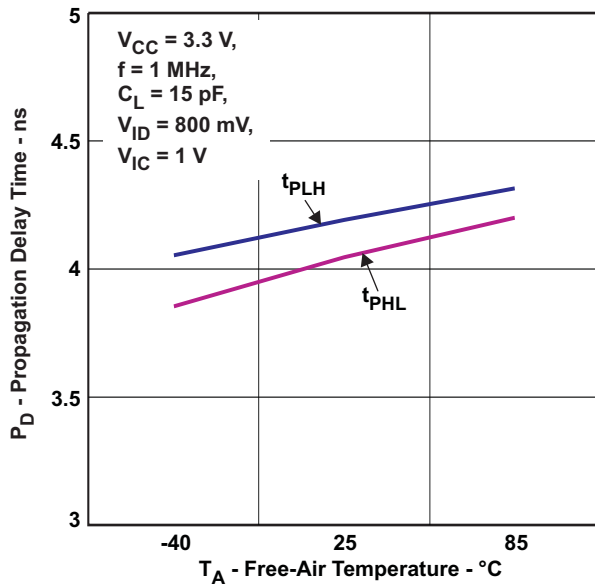

Figure 7.

**RECEIVER (TYPE-1) TRANSITION TIME
vs
FREE-AIR TEMPERATURE**

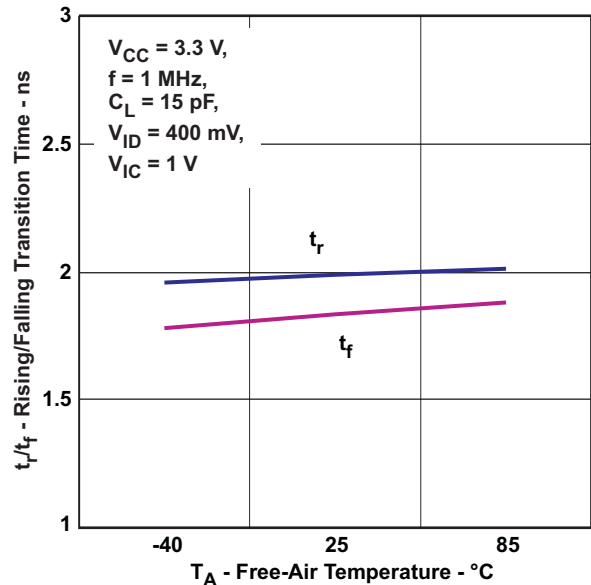

Figure 8.

TYPICAL CHARACTERISTICS (continued)

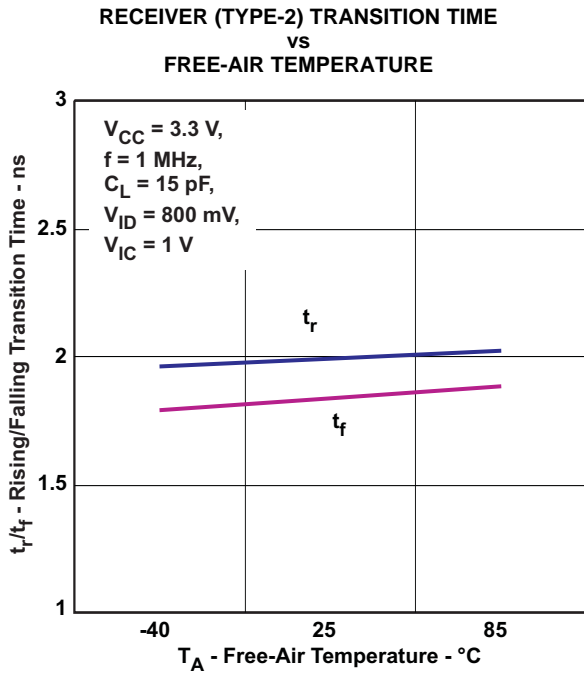

Figure 9.

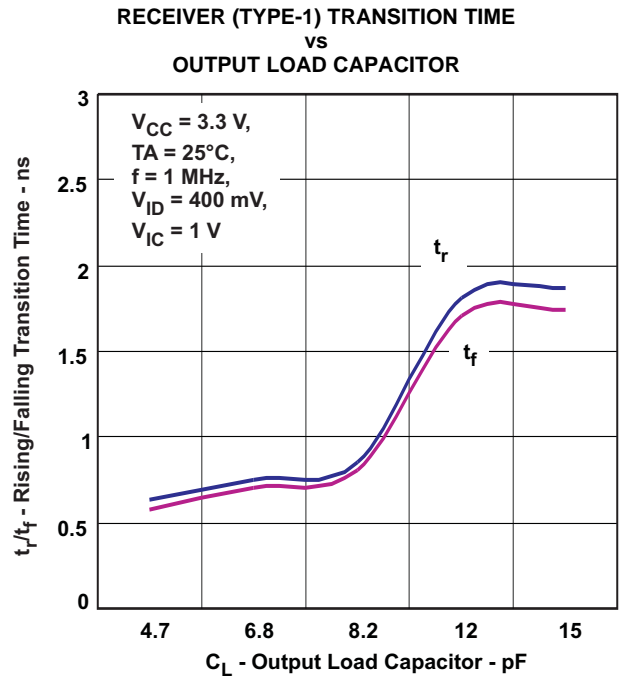

Figure 10.

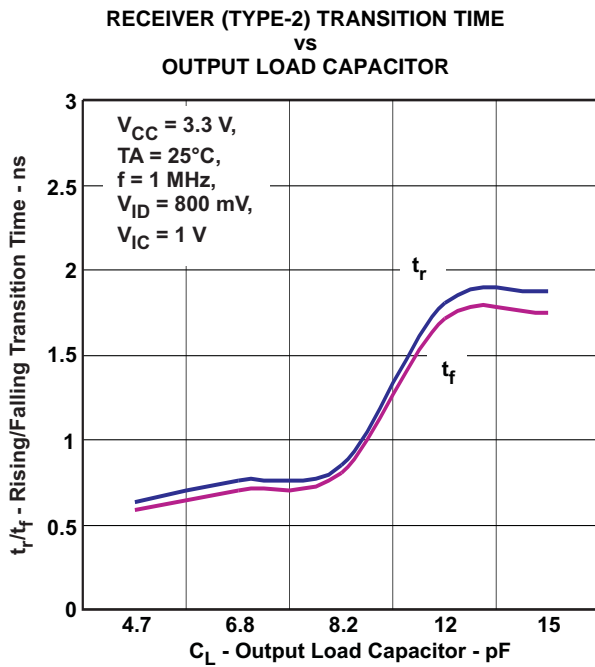

Figure 11.

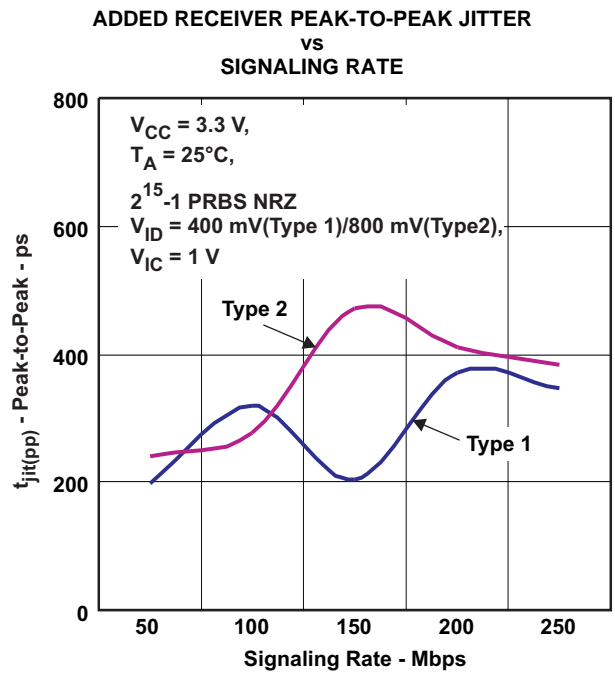

Figure 12.

TYPICAL CHARACTERISTICS (continued)

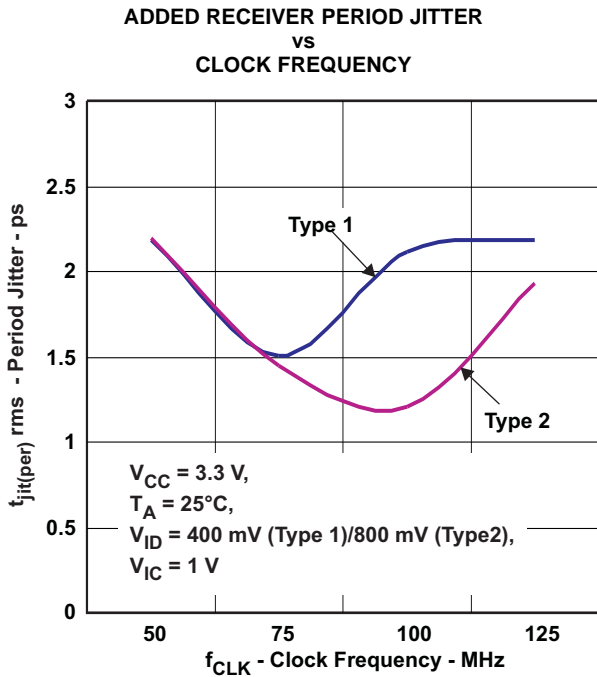

Figure 13.

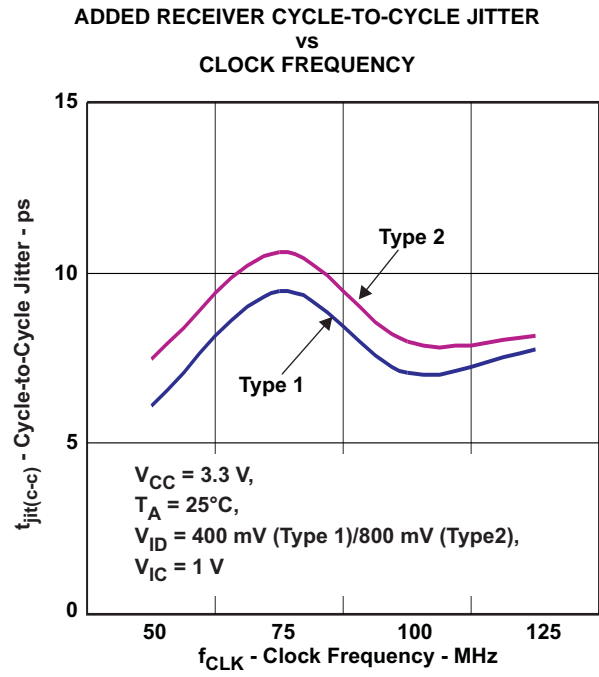

Figure 14.

EYE PATTERNS

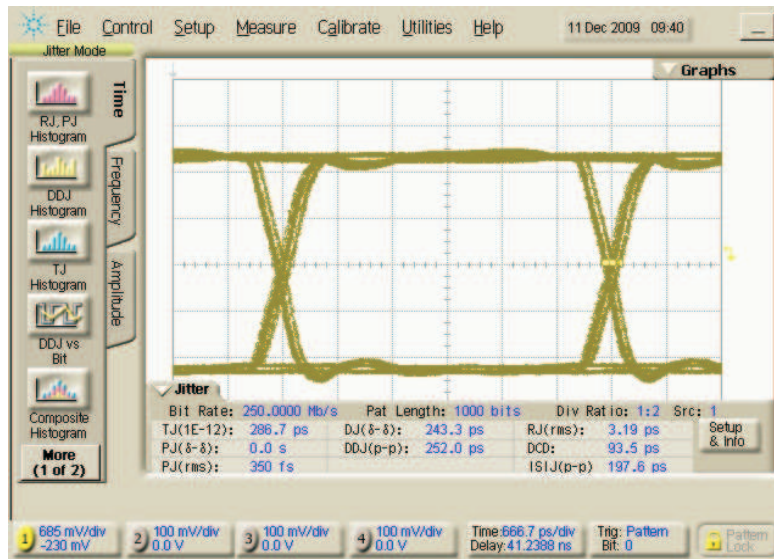

Figure 15. SN65MLVD048 Output ($V_{CC} = 3.3 \text{ V}$, $V_{ID} = 400 \text{ mV}$) 250 Mbps $2^{15}-1$ PRBS, Receiver Type 1

TYPICAL CHARACTERISTICS (continued)

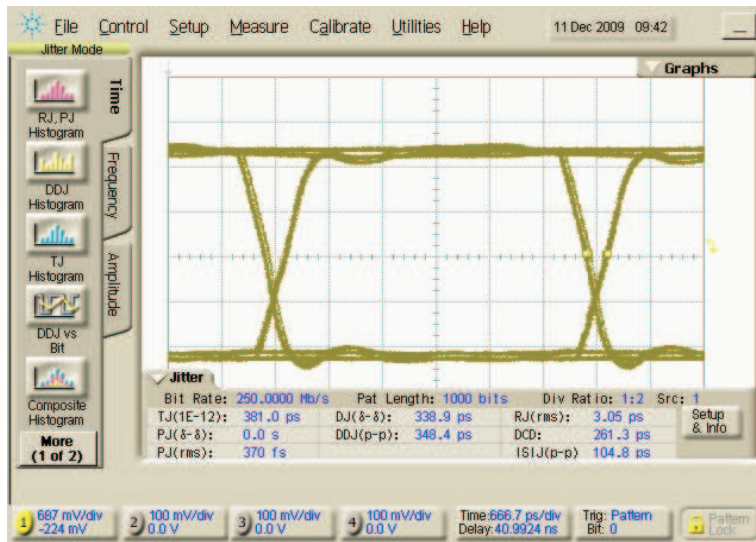

Figure 16. SN65MLVD048 Output ($V_{CC} = 3.3\text{ V}$, $V_{ID} = 800\text{ mV}$) 250 Mbps $2^{15}-1$ PRBS, Receiver Type 2

PACKAGING INFORMATION

Orderable Device	Status (1)	Package Type	Package Drawing	Pins	Package Qty	Eco Plan (2)	Lead/Ball Finish	MSL Peak Temp (3)	Op Temp (°C)	Top-Side Markings (4)	Samples
SN65MLVD048RGZR	ACTIVE	VQFN	RGZ	48	2500	Green (RoHS & no Sb/Br)	CU NIPDAU	Level-3-260C-168 HR	-40 to 85	MLVD048	Samples
SN65MLVD048RGZT	ACTIVE	VQFN	RGZ	48	250	Green (RoHS & no Sb/Br)	CU NIPDAU	Level-3-260C-168 HR	-40 to 85	MLVD048	Samples

(1) The marketing status values are defined as follows:

ACTIVE: Product device recommended for new designs.

LIFEBUY: TI has announced that the device will be discontinued, and a lifetime-buy period is in effect.

NRND: Not recommended for new designs. Device is in production to support existing customers, but TI does not recommend using this part in a new design.

PREVIEW: Device has been announced but is not in production. Samples may or may not be available.

OBsolete: TI has discontinued the production of the device.

(2) Eco Plan - The planned eco-friendly classification: Pb-Free (RoHS), Pb-Free (RoHS Exempt), or Green (RoHS & no Sb/Br) - please check <http://www.ti.com/productcontent> for the latest availability information and additional product content details.

TBD: The Pb-Free/Green conversion plan has not been defined.

Pb-Free (RoHS): TI's terms "Lead-Free" or "Pb-Free" mean semiconductor products that are compatible with the current RoHS requirements for all 6 substances, including the requirement that lead not exceed 0.1% by weight in homogeneous materials. Where designed to be soldered at high temperatures, TI Pb-Free products are suitable for use in specified lead-free processes.

Pb-Free (RoHS Exempt): This component has a RoHS exemption for either 1) lead-based flip-chip solder bumps used between the die and package, or 2) lead-based die adhesive used between the die and leadframe. The component is otherwise considered Pb-Free (RoHS compatible) as defined above.

Green (RoHS & no Sb/Br): TI defines "Green" to mean Pb-Free (RoHS compatible), and free of Bromine (Br) and Antimony (Sb) based flame retardants (Br or Sb do not exceed 0.1% by weight in homogeneous material)

(3) MSL, Peak Temp. -- The Moisture Sensitivity Level rating according to the JEDEC industry standard classifications, and peak solder temperature.

(4) Multiple Top-Side Markings will be inside parentheses. Only one Top-Side Marking contained in parentheses and separated by a "~" will appear on a device. If a line is indented then it is a continuation of the previous line and the two combined represent the entire Top-Side Marking for that device.

Important Information and Disclaimer: The information provided on this page represents TI's knowledge and belief as of the date that it is provided. TI bases its knowledge and belief on information provided by third parties, and makes no representation or warranty as to the accuracy of such information. Efforts are underway to better integrate information from third parties. TI has taken and continues to take reasonable steps to provide representative and accurate information but may not have conducted destructive testing or chemical analysis on incoming materials and chemicals. TI and TI suppliers consider certain information to be proprietary, and thus CAS numbers and other limited information may not be available for release.

In no event shall TI's liability arising out of such information exceed the total purchase price of the TI part(s) at issue in this document sold by TI to Customer on an annual basis.

TAPE AND REEL INFORMATION



QUADRANT ASSIGNMENTS FOR PIN 1 ORIENTATION IN TAPE



*All dimensions are nominal

Device	Package Type	Package Drawing	Pins	SPQ	Reel Diameter (mm)	Reel Width W1 (mm)	A0 (mm)	B0 (mm)	K0 (mm)	P1 (mm)	W (mm)	Pin1 Quadrant
SN65MLVD048RGZR	VQFN	RGZ	48	2500	330.0	16.4	7.3	7.3	1.5	12.0	16.0	Q2
SN65MLVD048RGZT	VQFN	RGZ	48	250	180.0	16.4	7.3	7.3	1.5	12.0	16.0	Q2

TAPE AND REEL BOX DIMENSIONS

*All dimensions are nominal

Device	Package Type	Package Drawing	Pins	SPQ	Length (mm)	Width (mm)	Height (mm)
SN65MLVD048RGZR	VQFN	RGZ	48	2500	367.0	367.0	38.0
SN65MLVD048RGZT	VQFN	RGZ	48	250	210.0	185.0	35.0

RGZ (S-PVQFN-N48)

PLASTIC QUAD FLATPACK NO-LEAD

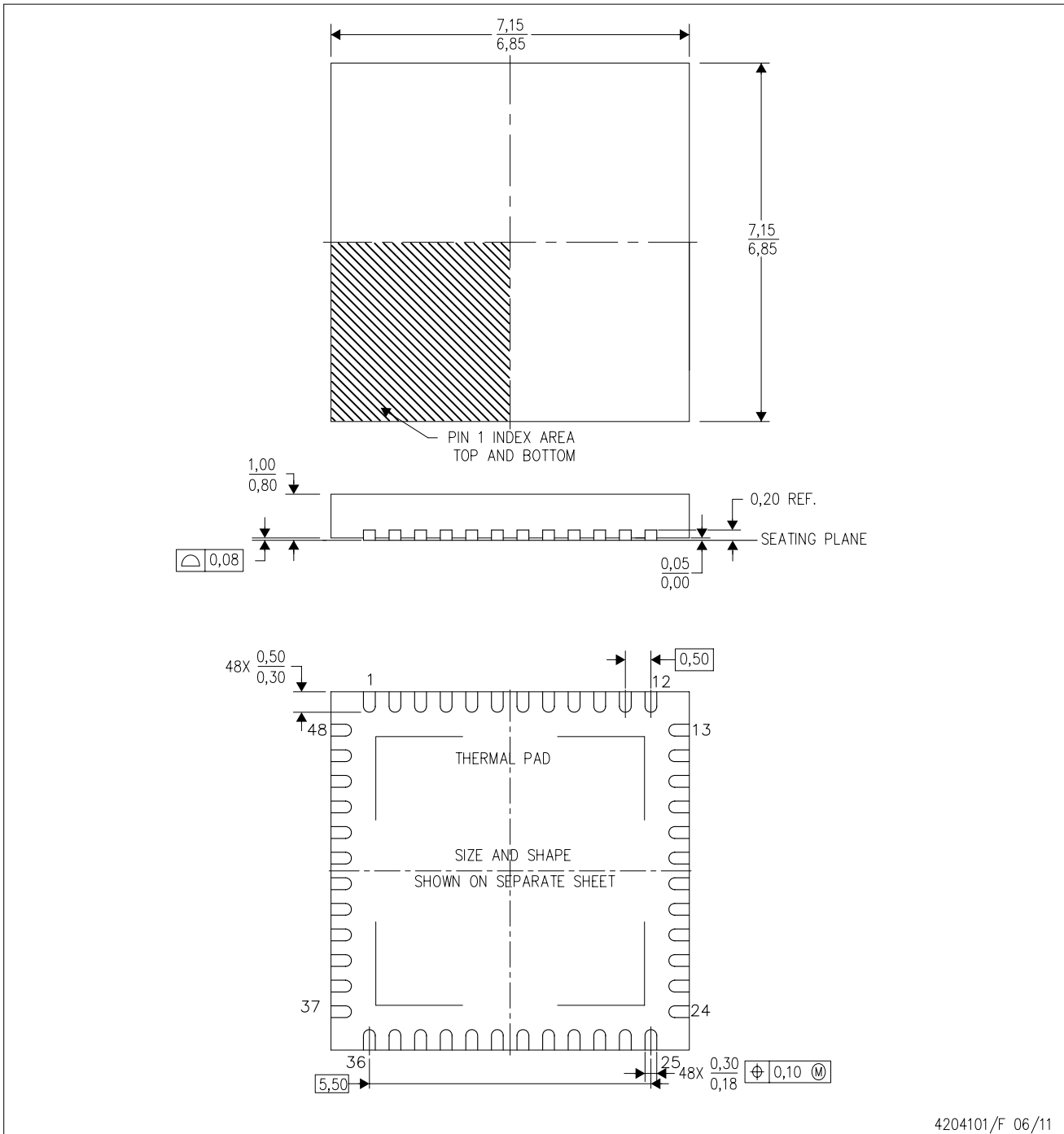

- NOTES:
- A. All linear dimensions are in millimeters. Dimensioning and tolerancing per ASME Y14.5M-1994.
 - B. This drawing is subject to change without notice.
 - C. Quad Flatpack, No-leads (QFN) package configuration.
 - D. The package thermal pad must be soldered to the board for thermal and mechanical performance.
 - E. See the additional figure in the Product Data Sheet for details regarding the exposed thermal pad features and dimensions.
 - F. Falls within JEDEC MO-220.

THEMAL INFORMATION

This package incorporates an exposed thermal pad that is designed to be attached directly to an external heatsink. The thermal pad must be soldered directly to the printed circuit board (PCB). After soldering, the PCB can be used as a heatsink. In addition, through the use of thermal vias, the thermal pad can be attached directly to the appropriate copper plane shown in the electrical schematic for the device, or alternatively, can be attached to a special heatsink structure designed into the PCB. This design optimizes the heat transfer from the integrated circuit (IC).

For information on the Quad Flatpack No-Lead (QFN) package and its advantages, refer to Application Report, QFN/SON PCB Attachment, Texas Instruments Literature No. SLUA271. This document is available at www.ti.com.

The exposed thermal pad dimensions for this package are shown in the following illustration.

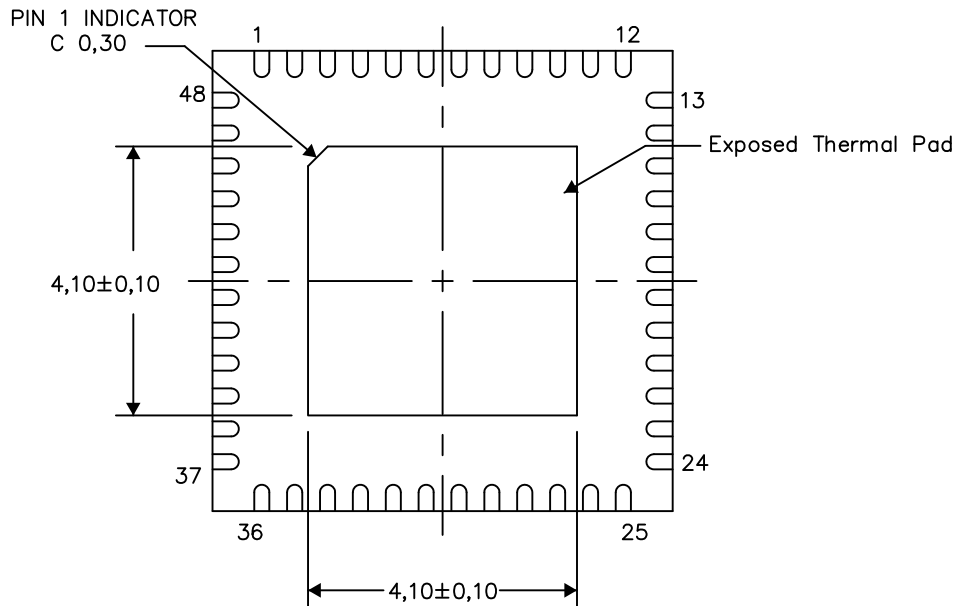

Bottom View

Exposed Thermal Pad Dimensions

4206354-3/Y 06/14

NOTE: All linear dimensions are in millimeters

RGZ (S-PVQFN-N48)

PLASTIC QUAD FLATPACK NO-LEAD

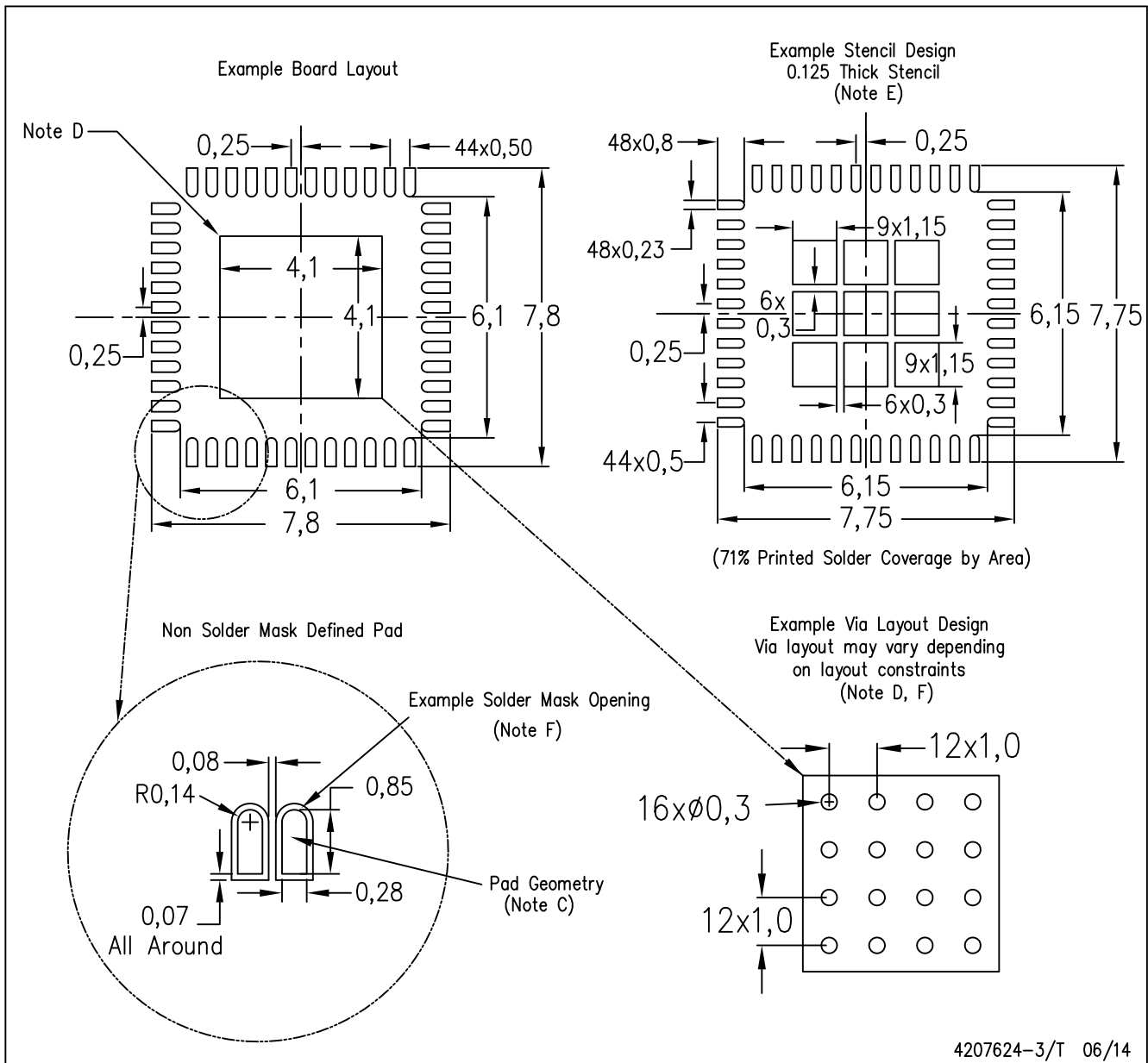

- NOTES:
- All linear dimensions are in millimeters.
 - This drawing is subject to change without notice.
 - Publication IPC-7351 is recommended for alternate designs.
 - This package is designed to be soldered to a thermal pad on the board. Refer to Application Note, Quad Flat-Pack Packages, Texas Instruments Literature No. SLUA271, and also the Product Data Sheets for specific thermal information, via requirements, and recommended board layout. These documents are available at www.ti.com <<http://www.ti.com>>.
 - Laser cutting apertures with trapezoidal walls and also rounding corners will offer better paste release. Customers should contact their board assembly site for stencil design recommendations. Refer to IPC 7525 for stencil design considerations.
 - Customers should contact their board fabrication site for recommended solder mask tolerances and via tenting recommendations for vias placed in the thermal pad.

IMPORTANT NOTICE

Texas Instruments Incorporated and its subsidiaries (TI) reserve the right to make corrections, enhancements, improvements and other changes to its semiconductor products and services per JESD46, latest issue, and to discontinue any product or service per JESD48, latest issue. Buyers should obtain the latest relevant information before placing orders and should verify that such information is current and complete. All semiconductor products (also referred to herein as "components") are sold subject to TI's terms and conditions of sale supplied at the time of order acknowledgment.

TI warrants performance of its components to the specifications applicable at the time of sale, in accordance with the warranty in TI's terms and conditions of sale of semiconductor products. Testing and other quality control techniques are used to the extent TI deems necessary to support this warranty. Except where mandated by applicable law, testing of all parameters of each component is not necessarily performed.

TI assumes no liability for applications assistance or the design of Buyers' products. Buyers are responsible for their products and applications using TI components. To minimize the risks associated with Buyers' products and applications, Buyers should provide adequate design and operating safeguards.

TI does not warrant or represent that any license, either express or implied, is granted under any patent right, copyright, mask work right, or other intellectual property right relating to any combination, machine, or process in which TI components or services are used. Information published by TI regarding third-party products or services does not constitute a license to use such products or services or a warranty or endorsement thereof. Use of such information may require a license from a third party under the patents or other intellectual property of the third party, or a license from TI under the patents or other intellectual property of TI.

Reproduction of significant portions of TI information in TI data books or data sheets is permissible only if reproduction is without alteration and is accompanied by all associated warranties, conditions, limitations, and notices. TI is not responsible or liable for such altered documentation. Information of third parties may be subject to additional restrictions.

Resale of TI components or services with statements different from or beyond the parameters stated by TI for that component or service voids all express and any implied warranties for the associated TI component or service and is an unfair and deceptive business practice. TI is not responsible or liable for any such statements.

Buyer acknowledges and agrees that it is solely responsible for compliance with all legal, regulatory and safety-related requirements concerning its products, and any use of TI components in its applications, notwithstanding any applications-related information or support that may be provided by TI. Buyer represents and agrees that it has all the necessary expertise to create and implement safeguards which anticipate dangerous consequences of failures, monitor failures and their consequences, lessen the likelihood of failures that might cause harm and take appropriate remedial actions. Buyer will fully indemnify TI and its representatives against any damages arising out of the use of any TI components in safety-critical applications.

In some cases, TI components may be promoted specifically to facilitate safety-related applications. With such components, TI's goal is to help enable customers to design and create their own end-product solutions that meet applicable functional safety standards and requirements. Nonetheless, such components are subject to these terms.

No TI components are authorized for use in FDA Class III (or similar life-critical medical equipment) unless authorized officers of the parties have executed a special agreement specifically governing such use.

Only those TI components which TI has specifically designated as military grade or "enhanced plastic" are designed and intended for use in military/aerospace applications or environments. Buyer acknowledges and agrees that any military or aerospace use of TI components which have **not** been so designated is solely at the Buyer's risk, and that Buyer is solely responsible for compliance with all legal and regulatory requirements in connection with such use.

TI has specifically designated certain components as meeting ISO/TS16949 requirements, mainly for automotive use. In any case of use of non-designated products, TI will not be responsible for any failure to meet ISO/TS16949.

Products

Audio	www.ti.com/audio
Amplifiers	amplifier.ti.com
Data Converters	dataconverter.ti.com
DLP® Products	www.dlp.com
DSP	dsp.ti.com
Clocks and Timers	www.ti.com/clocks
Interface	interface.ti.com
Logic	logic.ti.com
Power Mgmt	power.ti.com
Microcontrollers	microcontroller.ti.com
RFID	www.ti-rfid.com
OMAP Applications Processors	www.ti.com/omap
Wireless Connectivity	www.ti.com/wirelessconnectivity

Applications

Automotive and Transportation	www.ti.com/automotive
Communications and Telecom	www.ti.com/communications
Computers and Peripherals	www.ti.com/computers
Consumer Electronics	www.ti.com/consumer-apps
Energy and Lighting	www.ti.com/energy
Industrial	www.ti.com/industrial
Medical	www.ti.com/medical
Security	www.ti.com/security
Space, Avionics and Defense	www.ti.com/space-avionics-defense
Video and Imaging	www.ti.com/video

TI E2E Community

e2e.ti.com