

# SN54ABT823, SN74ABT823 9-BIT BUS-INTERFACE FLIP-FLOPS WITH 3-STATE OUTPUTS

SCBS158E – JANUARY 1991 – REVISED MAY 1997

- State-of-the-Art *EPIC-IIB™* BiCMOS Design Significantly Reduces Power Dissipation
- ESD Protection Exceeds 2000 V Per MIL-STD-883, Method 3015; Exceeds 200 V Using Machine Model (C = 200 pF, R = 0)
- Latch-Up Performance Exceeds 500 mA Per JEDEC Standard JESD-17
- Typical  $V_{OLP}$  (Output Ground Bounce) < 1 V at  $V_{CC} = 5$  V,  $T_A = 25^\circ\text{C}$
- High-Impedance State During Power Up and Power Down
- High-Drive Outputs (–32-mA  $I_{OH}$ , 64-mA  $I_{OL}$ )
- Buffered Control Inputs to Reduce dc Loading Effects
- Package Options Include Plastic Small-Outline (DW) and Shrink Small-Outline (DB) Packages, Ceramic Chip Carriers (FK) and Flatpacks (W), and Standard Plastic (NT) and Ceramic (JT) DIPs

## description

These 9-bit flip-flops feature 3-state outputs designed specifically for driving highly capacitive or relatively low-impedance loads. They are particularly suitable for implementing wider buffer registers, I/O ports, bidirectional bus drivers with parity, and working registers.

With the clock-enable ( $\overline{\text{CLKEN}}$ ) input low, the nine D-type edge-triggered flip-flops enter data on the low-to-high transitions of the clock. Taking  $\overline{\text{CLKEN}}$  high disables the clock buffer, thus latching the outputs. Taking the clear ( $\overline{\text{CLR}}$ ) input low causes the nine Q outputs to go low, independently of the clock.

A buffered output-enable ( $\overline{\text{OE}}$ ) input can be used to place the nine outputs in either a normal logic state (high or low logic level) or a high-impedance state. In the high-impedance state, the outputs neither load nor drive the bus lines significantly. The high-impedance state and increased drive provide the capability to drive bus lines without need for interface or pullup components.

When  $V_{CC}$  is between 0 and 2.1 V, the device is in the high-impedance state during power up or power down. However, to ensure the high-impedance state above 2.1 V,  $\overline{\text{OE}}$  should be tied to  $V_{CC}$  through a pullup resistor; the minimum value of the resistor is determined by the current-sinking capability of the driver.

The SN54ABT823 is characterized for operation over the full military temperature range of  $-55^\circ\text{C}$  to  $125^\circ\text{C}$ . The SN74ABT823 is characterized for operation from  $-40^\circ\text{C}$  to  $85^\circ\text{C}$ .

SN54ABT823 . . . JT OR W PACKAGE  
SN74ABT823 . . . DB, DW, OR NT PACKAGE  
(TOP VIEW)

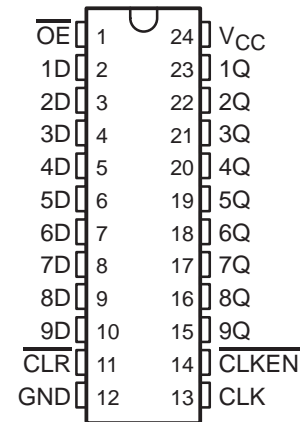

SN54ABT823 . . . FK PACKAGE  
(TOP VIEW)

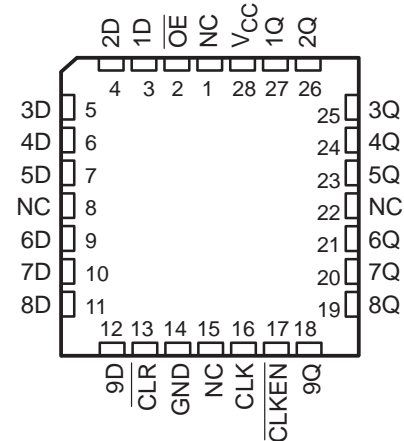

NC – No internal connection



Please be aware that an important notice concerning availability, standard warranty, and use in critical applications of Texas Instruments semiconductor products and disclaimers thereto appears at the end of this data sheet.

EPIC-IIB is a trademark of Texas Instruments Incorporated.

PRODUCTION DATA information is current as of publication date. Products conform to specifications per the terms of Texas Instruments standard warranty. Production processing does not necessarily include testing of all parameters.



POST OFFICE BOX 655303 • DALLAS, TEXAS 75265

Copyright © 1997, Texas Instruments Incorporated

# SN54ABT823, SN74ABT823 9-BIT BUS-INTERFACE FLIP-FLOPS WITH 3-STATE OUTPUTS

SCBS158E – JANUARY 1991 – REVISED MAY 1997

FUNCTION TABLE  
(each flip-flop)

INPUTS					OUTPUT
$\overline{OE}$	$\overline{CLR}$	$\overline{CLKEN}$	CLK	D	Q
L	L	X	X	X	L
L	H	L	↑	H	H
L	H	L	↑	L	L
L	H	H	X	X	Q <sub>0</sub>
H	X	X	X	X	Z

## logic symbol†

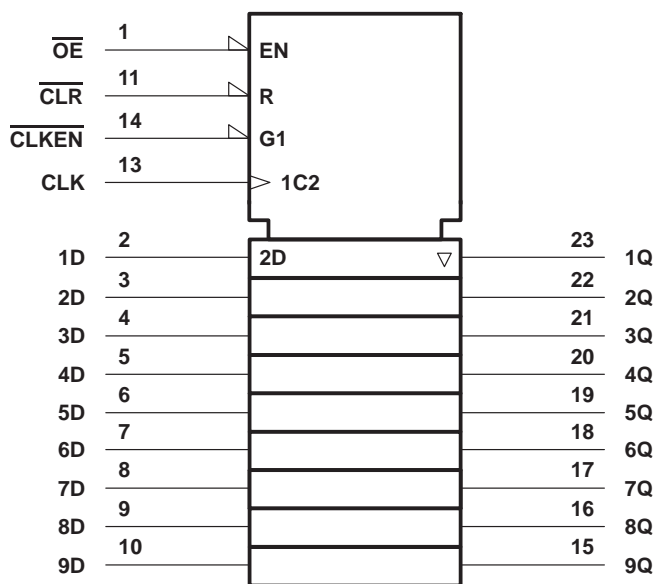

† This symbol is in accordance with ANSI/IEEE Std 91-1984 and IEC Publication 617-12. Pin numbers shown are for the DB, DW, JT, NT, and W packages.

**SN54ABT823, SN74ABT823**  
**9-BIT BUS-INTERFACE FLIP-FLOPS**  
**WITH 3-STATE OUTPUTS**

SCBS158E – JANUARY 1991 – REVISED MAY 1997

**logic diagram (positive logic)**

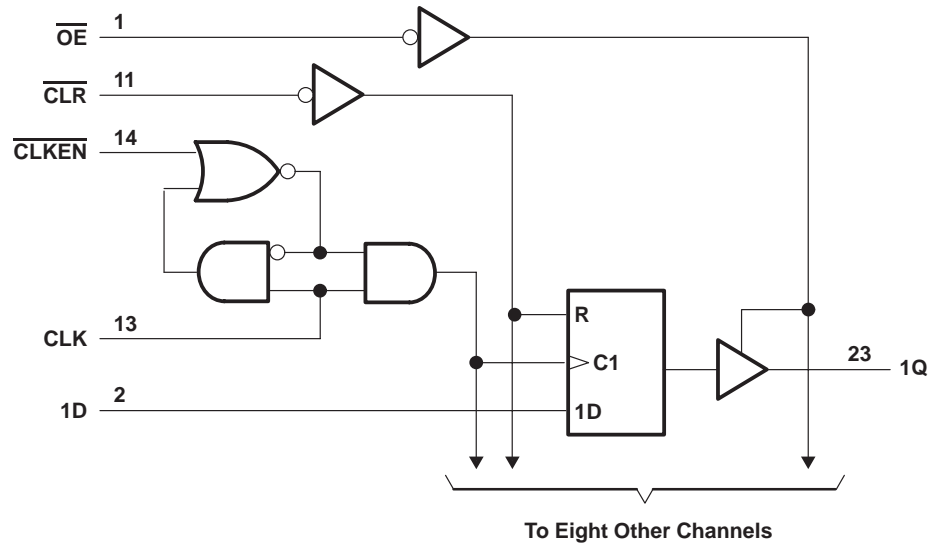

Pin numbers shown are for the DB, DW, JT, NT, and W packages.

**absolute maximum ratings over operating free-air temperature range (unless otherwise noted)†**

Supply voltage range, $V_{CC}$ .....	-0.5 V to 7 V
Input voltage range, $V_I$ (see Note 1) .....	-0.5 V to 7 V
Voltage range applied to any output in the high or power-off state, $V_O$ .....	-0.5 V to 5.5 V
Current into any output in the low state, $I_O$ : SN54ABT823 .....	96 mA
SN74ABT823 .....	128 mA
Input clamp current, $I_{IK}$ ( $V_I < 0$ ) .....	-18 mA
Output clamp current, $I_{OK}$ ( $V_O < 0$ ) .....	-50 mA
Package thermal impedance, $\theta_{JA}$ (see Note 2): DB package .....	104°C/W
DW package .....	81°C/W
NT package .....	67°C/W
Storage temperature range, $T_{Stg}$ .....	-65°C to 150°C

† Stresses beyond those listed under "absolute maximum ratings" may cause permanent damage to the device. This is a stress rating only, and functional operation of the device at these or any other conditions beyond those indicated in the "recommended operating conditions" section of this specification is not implied. Exposure to absolute-maximum-rated conditions for extended periods may affect device reliability.

- NOTES: 1. The input and output negative-voltage ratings may be exceeded if the input and output clamp-current ratings are observed.  
 2. The package thermal impedance is calculated in accordance with EIA/JEDEC Std JESD51, except for through-hole packages, which use a trace length of zero.

# SN54ABT823, SN74ABT823 9-BIT BUS-INTERFACE FLIP-FLOPS WITH 3-STATE OUTPUTS

SCBS158E – JANUARY 1991 – REVISED MAY 1997

## recommended operating conditions (see Note 3)

		SN54ABT823		SN74ABT823		UNIT
		MIN	MAX	MIN	MAX	
$V_{CC}$	Supply voltage	4.5	5.5	4.5	5.5	V
$V_{IH}$	High-level input voltage	2		2		V
$V_{IL}$	Low-level input voltage		0.8		0.8	V
$V_I$	Input voltage	0	$V_{CC}$	0	$V_{CC}$	V
$I_{OH}$	High-level output current		-24		-32	mA
$I_{OL}$	Low-level output current		48		64	mA
$\Delta t/\Delta v$	Input transition rise or fall rate		5		5	ns/V
$\Delta t/\Delta V_{CC}$	Power-up ramp rate	200		200		$\mu$ s/V
$T_A$	Operating free-air temperature	-55	125	-40	85	$^{\circ}$ C

NOTE 3: Unused inputs must be held high or low to prevent them from floating.

## electrical characteristics over recommended operating free-air temperature range (unless otherwise noted)

PARAMETER	TEST CONDITIONS	$T_A = 25^{\circ}$ C			SN54ABT823		SN74ABT823		UNIT
		MIN	TYP†	MAX	MIN	MAX	MIN	MAX	
$V_{IK}$	$V_{CC} = 4.5$ V, $I_I = -18$ mA			-1.2		-1.2		-1.2	V
$V_{OH}$	$V_{CC} = 4.5$ V, $I_{OH} = -3$ mA	2.5			2.5		2.5		V
	$V_{CC} = 5$ V, $I_{OH} = -3$ mA	3			3		3		
	$V_{CC} = 4.5$ V, $I_{OH} = -24$ mA	2			2			2	
$V_{OL}$	$V_{CC} = 4.5$ V	$I_{OL} = 48$ mA		0.55		0.55			V
		$I_{OL} = 64$ mA		0.55*			0.55		
$V_{hys}$			100						mV
$I_I$	$V_{CC} = 5.5$ V, $V_I = V_{CC}$ or GND			$\pm 1$		$\pm 1$		$\pm 1$	$\mu$ A
$I_{OZPU}^{\ddagger}$	$V_{CC} = 0$ to 2.1 V, $V_O = 0.5$ V to 2.7 V, $\overline{OE} = X$			$\pm 50$		$\pm 50$		$\pm 50$	$\mu$ A
$I_{OZPD}^{\ddagger}$	$V_{CC} = 2.1$ V to 0, $V_O = 0.5$ V to 2.7 V, $\overline{OE} = X$			$\pm 50$		$\pm 50$		$\pm 50$	$\mu$ A
$I_{OZH}$	$V_{CC} = 2.1$ V to 5.5 V, $V_O = 2.7$ V, $\overline{OE} \geq 2$ V			10§		10§		10§	$\mu$ A
$I_{OZL}$	$V_{CC} = 2.1$ V to 5.5 V, $V_O = 0.5$ V, $\overline{OE} \geq 2$ V			-10§		-10§		-10§	$\mu$ A
$I_{off}$	$V_{CC} = 0$ , $V_I$ or $V_O \leq 4.5$ V			$\pm 100$				$\pm 100$	$\mu$ A
$I_{CEX}$	$V_{CC} = 5.5$ V, $V_O = 5.5$ V			50		50		50	$\mu$ A
$I_{O}^{\parallel}$	$V_{CC} = 5.5$ V, $V_O = 2.5$ V	-50	-140	-180	-50	-180	-50	-180	mA
$I_{CC}$	$V_{CC} = 5.5$ V, $I_O = 0$ , $V_I = V_{CC}$ or GND	Outputs high	1	250	250	250	250	$\mu$ A	
		Outputs low	24	38	38	38	38	mA	
		Outputs disabled	0.5	250	250	250	250	$\mu$ A	
$\Delta I_{CC}^{\#}$	$V_{CC} = 5.5$ V, One input at 3.4 V, Other inputs at $V_{CC}$ or GND			1.5		1.5		1.5	mA
$C_i$	$V_I = 2.5$ V or 0.5 V			4					pF
$C_o$	$V_O = 2.5$ V or 0.5 V			7					pF

\* On products compliant to MIL-PRF-38535, this parameter does not apply.

† All typical values are at  $V_{CC} = 5$  V.

‡ This parameter is characterized, but not production tested.

§ This data sheet limit may vary among suppliers.

¶ Not more than one output should be tested at a time, and the duration of the test should not exceed one second.

# This is the increase in supply current for each input that is at the specified TTL voltage level rather than  $V_{CC}$  or GND.



**SN54ABT823, SN74ABT823**  
**9-BIT BUS-INTERFACE FLIP-FLOPS**  
**WITH 3-STATE OUTPUTS**

SCBS158E – JANUARY 1991 – REVISED MAY 1997

timing requirements over recommended ranges of supply voltage and operating free-air temperature (unless otherwise noted) (see Figure 1)

		$V_{CC} = 5\text{ V},$ $T_A = 25^\circ\text{C}$		SN54ABT823		SN74ABT823		UNIT
		MIN	MAX	MIN	MAX	MIN	MAX	
$f_{\text{clock}}$	Clock frequency	0	125	0	125	0	125	MHz
$t_w$	Pulse duration	CLR low	5.5	5.5	5.5	5.5	5.5	ns
		CLK high	2.9	2.9	2.9	2.9		
		CLK low	3.8	3.8	3.8	3.8		
$t_{\text{su}}$	Setup time before CLK $\uparrow$	CLR inactive	2.5	2.5	2.5	2.5	2.5	ns
		Data	2.1	2.1	2.1	2.1		
		CLKEN high	2	2	2	2		
		CLKEN low	3.3	3.3	3.3	3.3		
$t_h$	Hold time after CLK $\uparrow$	Data	1.3	1.3	1.3	1.3	ns	
		CLKEN high	1	1	1	1		
		CLKEN low	2	2	2	2		

switching characteristics over recommended ranges of supply voltage and operating free-air temperature,  $C_L = 50\text{ pF}$  (unless otherwise noted) (see Figure 1)

PARAMETER	FROM (INPUT)	TO (OUTPUT)	$V_{CC} = 5\text{ V},$ $T_A = 25^\circ\text{C}$			SN54ABT823		SN74ABT823		UNIT
			MIN	TYP	MAX	MIN	MAX	MIN	MAX	
$f_{\text{max}}$			125	200		125		125		MHz
$t_{\text{PLH}}$	CLK	Q	2.1	4.3	5.9	2.1	8.1	2.1	6.8	ns
$t_{\text{PHL}}$			2.2	4.4	6.1	2.2	7	2.2	6.7	
$t_{\text{PHL}}$	$\overline{\text{CLR}}$	Q	2	4.1	6.3	2	7.3	2	7.1	ns
$t_{\text{PZH}}$	$\overline{\text{OE}}$	Q	1	3	4.7 $\dagger$	1	6.3	1	6 $\dagger$	ns
$t_{\text{PZL}}$			2.2	4.1	5.6	2.2	6.6	2.2	6.5 $\dagger$	
$t_{\text{PHZ}}$	$\overline{\text{OE}}$	Q	2.7	4.8	6.5 $\dagger$	2.7	7.7	2.7	7.5 $\dagger$	ns
$t_{\text{PLZ}}$			1.9	5	6.4	1.9	7.4	1.9	6.9	

$\dagger$  This data sheet limit may vary among suppliers.

**SN54ABT823, SN74ABT823**  
**9-BIT BUS-INTERFACE FLIP-FLOPS**  
**WITH 3-STATE OUTPUTS**

SCBS158E – JANUARY 1991 – REVISED MAY 1997

**PARAMETER MEASUREMENT INFORMATION**

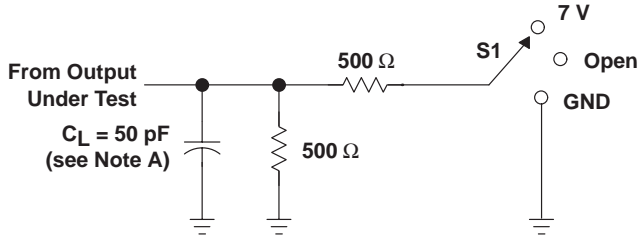

**LOAD CIRCUIT**

TEST	S1
$t_{PLH}/t_{PHL}$	Open
$t_{PLZ}/t_{PZL}$	7 V
$t_{PHZ}/t_{PZH}$	Open

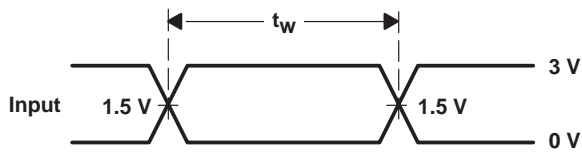

**VOLTAGE WAVEFORMS**  
**PULSE DURATION**

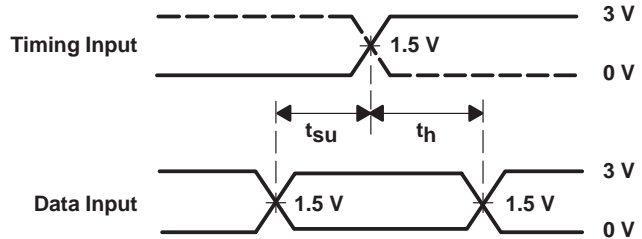

**VOLTAGE WAVEFORMS**  
**SETUP AND HOLD TIMES**

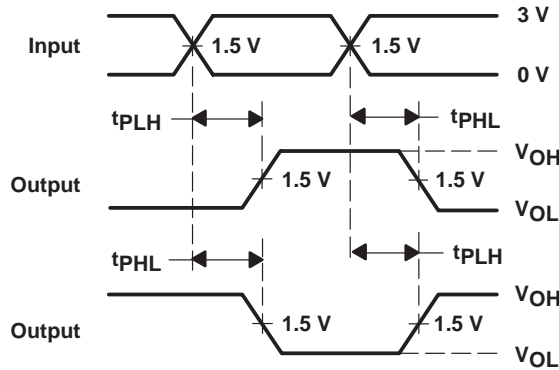

**VOLTAGE WAVEFORMS**  
**PROPAGATION DELAY TIMES**  
**INVERTING AND NONINVERTING OUTPUTS**

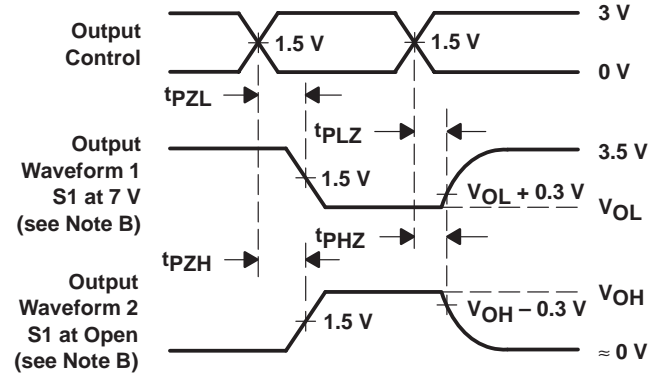

**VOLTAGE WAVEFORMS**  
**ENABLE AND DISABLE TIMES**  
**LOW- AND HIGH-LEVEL ENABLING**

- NOTES: A.  $C_L$  includes probe and jig capacitance.  
 B. Waveform 1 is for an output with internal conditions such that the output is low except when disabled by the output control. Waveform 2 is for an output with internal conditions such that the output is high except when disabled by the output control.  
 C. All input pulses are supplied by generators having the following characteristics:  $PRR \leq 10 \text{ MHz}$ ,  $Z_O = 50 \Omega$ ,  $t_r \leq 2.5 \text{ ns}$ ,  $t_f \leq 2.5 \text{ ns}$ .  
 D. The outputs are measured one at a time with one transition per measurement.

**Figure 1. Load Circuit and Voltage Waveforms**

**PACKAGING INFORMATION**

Orderable Device	Status (1)	Package Type	Package Drawing	Pins	Package Qty	Eco Plan (2)	Lead/Ball Finish (6)	MSL Peak Temp (3)	Op Temp (°C)	Device Marking (4/5)	Samples
5962-9450801Q3A	ACTIVE	LCCC	FK	28	1	TBD	POST-PLATE	N / A for Pkg Type	-55 to 125	5962-9450801Q3A SNJ54 ABT823FK	<a href="#">Samples</a>
5962-9450801QKA	ACTIVE	CFP	W	24	1	TBD	A42	N / A for Pkg Type	-55 to 125	5962-9450801QK A SNJ54ABT823W	<a href="#">Samples</a>
5962-9450801QLA	ACTIVE	CDIP	JT	24	1	TBD	A42	N / A for Pkg Type	-55 to 125	5962-9450801QL A SNJ54ABT823JT	<a href="#">Samples</a>
SN74ABT823DBLE	OBSOLETE	SSOP	DB	24		TBD	Call TI	Call TI	-40 to 85		
SN74ABT823DBR	ACTIVE	SSOP	DB	24	2000	Green (RoHS & no Sb/Br)	CU NIPDAU	Level-1-260C-UNLIM	-40 to 85	AB823	<a href="#">Samples</a>
SN74ABT823DBRG4	ACTIVE	SSOP	DB	24	2000	Green (RoHS & no Sb/Br)	CU NIPDAU	Level-1-260C-UNLIM	-40 to 85	AB823	<a href="#">Samples</a>
SN74ABT823DW	ACTIVE	SOIC	DW	24	25	Green (RoHS & no Sb/Br)	CU NIPDAU	Level-1-260C-UNLIM	-40 to 85	ABT823	<a href="#">Samples</a>
SN74ABT823DWR	ACTIVE	SOIC	DW	24	2000	Green (RoHS & no Sb/Br)	CU NIPDAU	Level-1-260C-UNLIM	-40 to 85	ABT823	<a href="#">Samples</a>
SNJ54ABT823FK	ACTIVE	LCCC	FK	28	1	TBD	POST-PLATE	N / A for Pkg Type	-55 to 125	5962-9450801Q3A SNJ54 ABT823FK	<a href="#">Samples</a>
SNJ54ABT823JT	ACTIVE	CDIP	JT	24	1	TBD	A42	N / A for Pkg Type	-55 to 125	5962-9450801QL A SNJ54ABT823JT	<a href="#">Samples</a>
SNJ54ABT823W	ACTIVE	CFP	W	24	1	TBD	A42	N / A for Pkg Type	-55 to 125	5962-9450801QK A SNJ54ABT823W	<a href="#">Samples</a>

(1) The marketing status values are defined as follows:

**ACTIVE:** Product device recommended for new designs.

**LIFEBUY:** TI has announced that the device will be discontinued, and a lifetime-buy period is in effect.

**NRND:** Not recommended for new designs. Device is in production to support existing customers, but TI does not recommend using this part in a new design.

**PREVIEW:** Device has been announced but is not in production. Samples may or may not be available.

**OBSOLETE:** TI has discontinued the production of the device.

(2) Eco Plan - The planned eco-friendly classification: Pb-Free (RoHS), Pb-Free (RoHS Exempt), or Green (RoHS & no Sb/Br) - please check <http://www.ti.com/productcontent> for the latest availability information and additional product content details.

**TBD:** The Pb-Free/Green conversion plan has not been defined.

**Pb-Free (RoHS):** TI's terms "Lead-Free" or "Pb-Free" mean semiconductor products that are compatible with the current RoHS requirements for all 6 substances, including the requirement that lead not exceed 0.1% by weight in homogeneous materials. Where designed to be soldered at high temperatures, TI Pb-Free products are suitable for use in specified lead-free processes.

**Pb-Free (RoHS Exempt):** This component has a RoHS exemption for either 1) lead-based flip-chip solder bumps used between the die and package, or 2) lead-based die adhesive used between the die and leadframe. The component is otherwise considered Pb-Free (RoHS compatible) as defined above.

**Green (RoHS & no Sb/Br):** TI defines "Green" to mean Pb-Free (RoHS compatible), and free of Bromine (Br) and Antimony (Sb) based flame retardants (Br or Sb do not exceed 0.1% by weight in homogeneous material)

(3) MSL, Peak Temp. - The Moisture Sensitivity Level rating according to the JEDEC industry standard classifications, and peak solder temperature.

(4) There may be additional marking, which relates to the logo, the lot trace code information, or the environmental category on the device.

(5) Multiple Device Markings will be inside parentheses. Only one Device Marking contained in parentheses and separated by a "~" will appear on a device. If a line is indented then it is a continuation of the previous line and the two combined represent the entire Device Marking for that device.

(6) Lead/Ball Finish - Orderable Devices may have multiple material finish options. Finish options are separated by a vertical ruled line. Lead/Ball Finish values may wrap to two lines if the finish value exceeds the maximum column width.

**Important Information and Disclaimer:** The information provided on this page represents TI's knowledge and belief as of the date that it is provided. TI bases its knowledge and belief on information provided by third parties, and makes no representation or warranty as to the accuracy of such information. Efforts are underway to better integrate information from third parties. TI has taken and continues to take reasonable steps to provide representative and accurate information but may not have conducted destructive testing or chemical analysis on incoming materials and chemicals. TI and TI suppliers consider certain information to be proprietary, and thus CAS numbers and other limited information may not be available for release.

In no event shall TI's liability arising out of such information exceed the total purchase price of the TI part(s) at issue in this document sold by TI to Customer on an annual basis.

**OTHER QUALIFIED VERSIONS OF SN54ABT823, SN74ABT823 :**

● Catalog: [SN74ABT823](#)

● Military: [SN54ABT823](#)

NOTE: Qualified Version Definitions:

● Catalog - TI's standard catalog product

- Military - QML certified for Military and Defense Applications

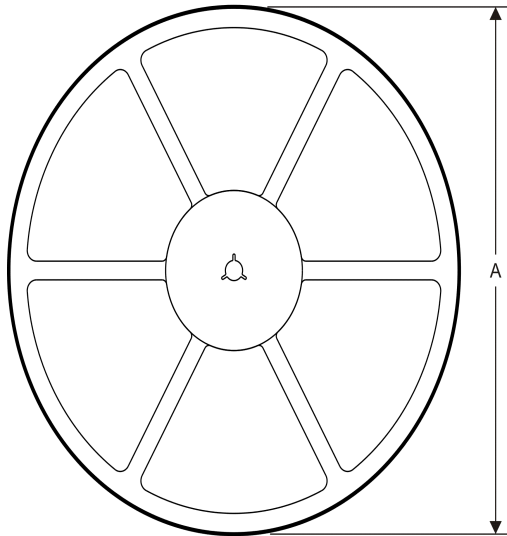
**TAPE AND REEL INFORMATION**
**REEL DIMENSIONS**

**TAPE DIMENSIONS**

A0	Dimension designed to accommodate the component width
B0	Dimension designed to accommodate the component length
K0	Dimension designed to accommodate the component thickness
W	Overall width of the carrier tape
P1	Pitch between successive cavity centers

**TAPE AND REEL INFORMATION**

\*All dimensions are nominal

Device	Package Type	Package Drawing	Pins	SPQ	Reel Diameter (mm)	Reel Width W1 (mm)	A0 (mm)	B0 (mm)	K0 (mm)	P1 (mm)	W (mm)	Pin1 Quadrant
SN74ABT823DBR	SSOP	DB	24	2000	330.0	16.4	8.2	8.8	2.5	12.0	16.0	Q1
SN74ABT823DWR	SOIC	DW	24	2000	330.0	24.4	10.75	15.7	2.7	12.0	24.0	Q1

**TAPE AND REEL BOX DIMENSIONS**

\*All dimensions are nominal

Device	Package Type	Package Drawing	Pins	SPQ	Length (mm)	Width (mm)	Height (mm)
SN74ABT823DBR	SSOP	DB	24	2000	367.0	367.0	38.0
SN74ABT823DWR	SOIC	DW	24	2000	367.0	367.0	45.0

JT (R-GDIP-T\*\*)

CERAMIC DUAL-IN-LINE

24 LEADS SHOWN



- NOTES: A. All linear dimensions are in inches (millimeters).  
 B. This drawing is subject to change without notice.  
 C. This package can be hermetically sealed with a ceramic lid using glass frit.  
 D. Index point is provided on cap for terminal identification.  
 E. Falls within MIL STD 1835 GDIP3-T24, GDIP4-T28, and JEDEC MO-058 AA, MO-058 AB

W (R-GDFP-F24)

CERAMIC DUAL FLATPACK

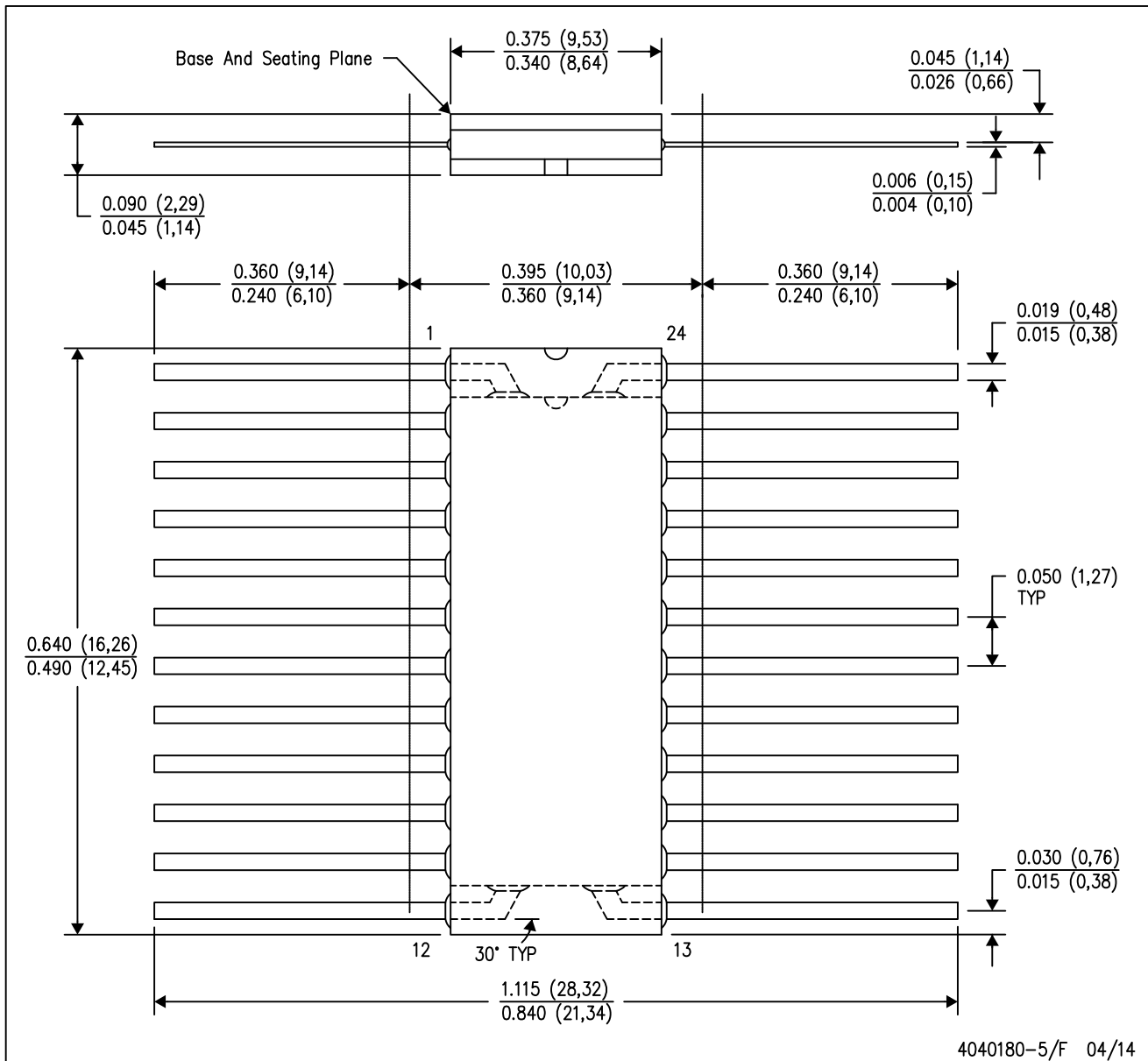

- NOTES:
- A. All linear dimensions are in inches (millimeters).
  - B. This drawing is subject to change without notice.
  - C. This package can be hermetically sealed with a ceramic lid using glass frit.
  - D. Index point is provided on cap for terminal identification only.
  - E. Falls within Mil-Std 1835 GDFP2-F20

FK (S-CQCC-N\*\*)

LEADLESS CERAMIC CHIP CARRIER

28 TERMINAL SHOWN



NO. OF TERMINALS **	A		B	
	MIN	MAX	MIN	MAX
20	0.342 (8,69)	0.358 (9,09)	0.307 (7,80)	0.358 (9,09)
28	0.442 (11,23)	0.458 (11,63)	0.406 (10,31)	0.458 (11,63)
44	0.640 (16,26)	0.660 (16,76)	0.495 (12,58)	0.560 (14,22)
52	0.740 (18,78)	0.761 (19,32)	0.495 (12,58)	0.560 (14,22)
68	0.938 (23,83)	0.962 (24,43)	0.850 (21,6)	0.858 (21,8)
84	1.141 (28,99)	1.165 (29,59)	1.047 (26,6)	1.063 (27,0)



4040140/D 01/11

- NOTES:
- All linear dimensions are in inches (millimeters).
  - This drawing is subject to change without notice.
  - This package can be hermetically sealed with a metal lid.
  - Falls within JEDEC MS-004

DW (R-PDSO-G24)

PLASTIC SMALL OUTLINE



- NOTES:
- A. All linear dimensions are in inches (millimeters). Dimensioning and tolerancing per ASME Y14.5M-1994.
  - B. This drawing is subject to change without notice.
  - C. Body dimensions do not include mold flash or protrusion not to exceed 0.006 (0,15).
  - D. Falls within JEDEC MS-013 variation AD.

DW (R-PDSO-G24)

PLASTIC SMALL OUTLINE

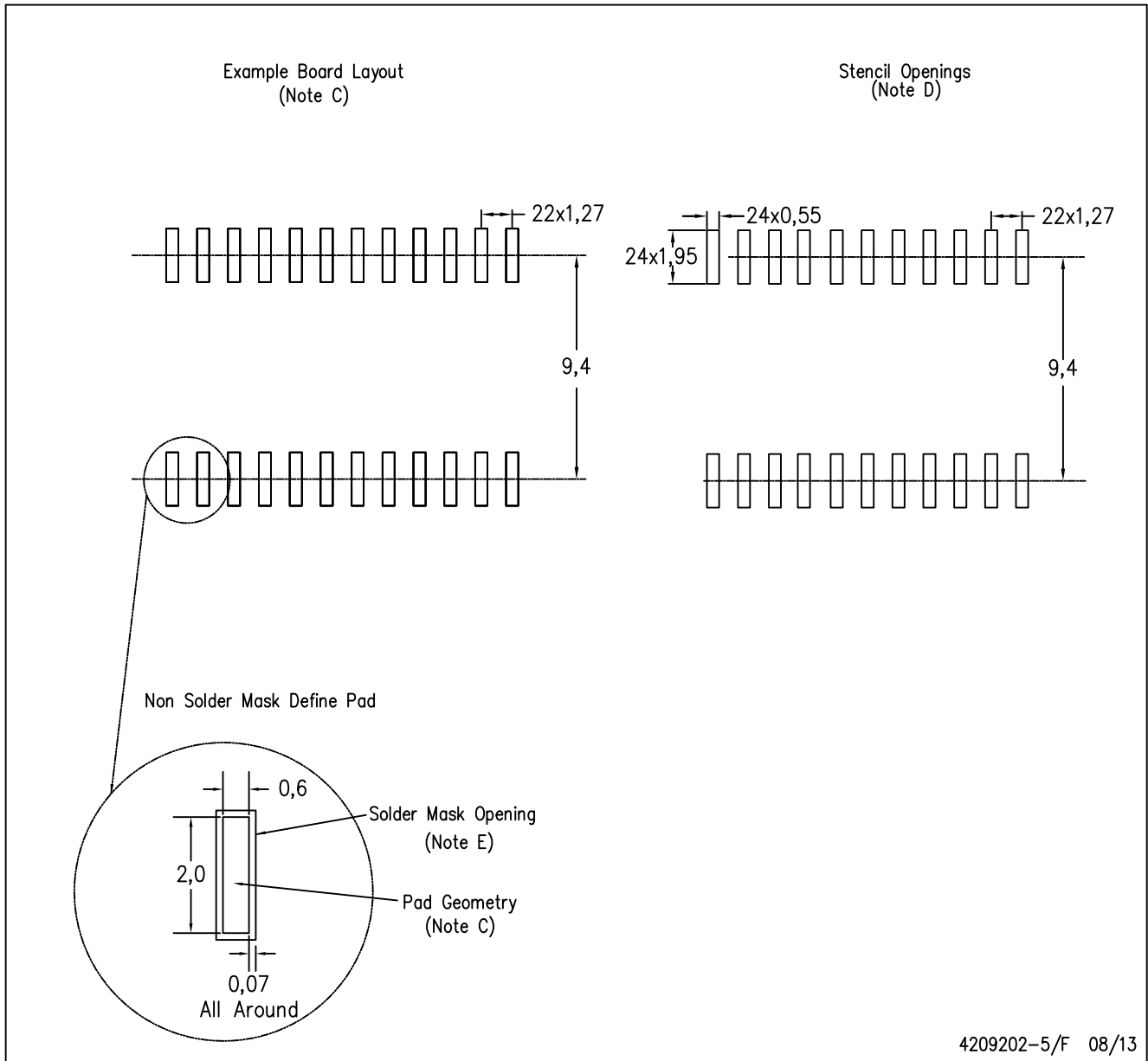

4209202-5/F 08/13

- NOTES:
- A. All linear dimensions are in millimeters.
  - B. This drawing is subject to change without notice.
  - C. Refer to IPC7351 for alternate board design.
  - D. Laser cutting apertures with trapezoidal walls and also rounding corners will offer better paste release. Customers should contact their board assembly site for stencil design recommendations. Refer to IPC-7525
  - E. Customers should contact their board fabrication site for solder mask tolerances between and around signal pads.

DB (R-PDSO-G\*\*)

PLASTIC SMALL-OUTLINE

28 PINS SHOWN



- NOTES: A. All linear dimensions are in millimeters.  
 B. This drawing is subject to change without notice.  
 C. Body dimensions do not include mold flash or protrusion not to exceed 0,15.  
 D. Falls within JEDEC MO-150

## IMPORTANT NOTICE

Texas Instruments Incorporated and its subsidiaries (TI) reserve the right to make corrections, enhancements, improvements and other changes to its semiconductor products and services per JESD46, latest issue, and to discontinue any product or service per JESD48, latest issue. Buyers should obtain the latest relevant information before placing orders and should verify that such information is current and complete. All semiconductor products (also referred to herein as "components") are sold subject to TI's terms and conditions of sale supplied at the time of order acknowledgment.

TI warrants performance of its components to the specifications applicable at the time of sale, in accordance with the warranty in TI's terms and conditions of sale of semiconductor products. Testing and other quality control techniques are used to the extent TI deems necessary to support this warranty. Except where mandated by applicable law, testing of all parameters of each component is not necessarily performed.

TI assumes no liability for applications assistance or the design of Buyers' products. Buyers are responsible for their products and applications using TI components. To minimize the risks associated with Buyers' products and applications, Buyers should provide adequate design and operating safeguards.

TI does not warrant or represent that any license, either express or implied, is granted under any patent right, copyright, mask work right, or other intellectual property right relating to any combination, machine, or process in which TI components or services are used. Information published by TI regarding third-party products or services does not constitute a license to use such products or services or a warranty or endorsement thereof. Use of such information may require a license from a third party under the patents or other intellectual property of the third party, or a license from TI under the patents or other intellectual property of TI.

Reproduction of significant portions of TI information in TI data books or data sheets is permissible only if reproduction is without alteration and is accompanied by all associated warranties, conditions, limitations, and notices. TI is not responsible or liable for such altered documentation. Information of third parties may be subject to additional restrictions.

Resale of TI components or services with statements different from or beyond the parameters stated by TI for that component or service voids all express and any implied warranties for the associated TI component or service and is an unfair and deceptive business practice. TI is not responsible or liable for any such statements.

Buyer acknowledges and agrees that it is solely responsible for compliance with all legal, regulatory and safety-related requirements concerning its products, and any use of TI components in its applications, notwithstanding any applications-related information or support that may be provided by TI. Buyer represents and agrees that it has all the necessary expertise to create and implement safeguards which anticipate dangerous consequences of failures, monitor failures and their consequences, lessen the likelihood of failures that might cause harm and take appropriate remedial actions. Buyer will fully indemnify TI and its representatives against any damages arising out of the use of any TI components in safety-critical applications.

In some cases, TI components may be promoted specifically to facilitate safety-related applications. With such components, TI's goal is to help enable customers to design and create their own end-product solutions that meet applicable functional safety standards and requirements. Nonetheless, such components are subject to these terms.

No TI components are authorized for use in FDA Class III (or similar life-critical medical equipment) unless authorized officers of the parties have executed a special agreement specifically governing such use.

Only those TI components which TI has specifically designated as military grade or "enhanced plastic" are designed and intended for use in military/aerospace applications or environments. Buyer acknowledges and agrees that any military or aerospace use of TI components which have **not** been so designated is solely at the Buyer's risk, and that Buyer is solely responsible for compliance with all legal and regulatory requirements in connection with such use.

TI has specifically designated certain components as meeting ISO/TS16949 requirements, mainly for automotive use. In any case of use of non-designated products, TI will not be responsible for any failure to meet ISO/TS16949.

### Products

Audio	<a href="http://www.ti.com/audio">www.ti.com/audio</a>
Amplifiers	<a href="http://amplifier.ti.com">amplifier.ti.com</a>
Data Converters	<a href="http://dataconverter.ti.com">dataconverter.ti.com</a>
DLP® Products	<a href="http://www.dlp.com">www.dlp.com</a>
DSP	<a href="http://dsp.ti.com">dsp.ti.com</a>
Clocks and Timers	<a href="http://www.ti.com/clocks">www.ti.com/clocks</a>
Interface	<a href="http://interface.ti.com">interface.ti.com</a>
Logic	<a href="http://logic.ti.com">logic.ti.com</a>
Power Mgmt	<a href="http://power.ti.com">power.ti.com</a>
Microcontrollers	<a href="http://microcontroller.ti.com">microcontroller.ti.com</a>
RFID	<a href="http://www.ti-rfid.com">www.ti-rfid.com</a>
OMAP Applications Processors	<a href="http://www.ti.com/omap">www.ti.com/omap</a>
Wireless Connectivity	<a href="http://www.ti.com/wirelessconnectivity">www.ti.com/wirelessconnectivity</a>

### Applications

Automotive and Transportation	<a href="http://www.ti.com/automotive">www.ti.com/automotive</a>
Communications and Telecom	<a href="http://www.ti.com/communications">www.ti.com/communications</a>
Computers and Peripherals	<a href="http://www.ti.com/computers">www.ti.com/computers</a>
Consumer Electronics	<a href="http://www.ti.com/consumer-apps">www.ti.com/consumer-apps</a>
Energy and Lighting	<a href="http://www.ti.com/energy">www.ti.com/energy</a>
Industrial	<a href="http://www.ti.com/industrial">www.ti.com/industrial</a>
Medical	<a href="http://www.ti.com/medical">www.ti.com/medical</a>
Security	<a href="http://www.ti.com/security">www.ti.com/security</a>
Space, Avionics and Defense	<a href="http://www.ti.com/space-avionics-defense">www.ti.com/space-avionics-defense</a>
Video and Imaging	<a href="http://www.ti.com/video">www.ti.com/video</a>

### TI E2E Community

[e2e.ti.com](http://e2e.ti.com)