

# SN54ALS646, SN54ALS648, SN54AS646 SN74ALS646A, SN74ALS648A, SN74AS646, SN74AS648 OCTAL BUS TRANSCEIVERS AND REGISTERS WITH 3-STATE OUTPUTS

SDAS039F – DECEMBER 1983 – REVISED JANUARY 1995

- Independent Registers for A and B Buses
- Multiplexed Real-Time and Stored Data
- Choice of True or Inverting Data Paths
- Choice of 3-State or Open-Collector Outputs
- Package Options Include Plastic Small-Outline (DW) Packages, Ceramic Chip Carriers (FK), and Standard Plastic (NT) and Ceramic (JT) 300-mil DIPs

SN54ALS646, SN54ALS648, SN54AS646 . . . JT PACKAGE  
SN74ALS646A, SN74ALS648A, SN74AS646,  
SN74AS648 . . . DW OR NT PACKAGE  
(TOP VIEW)

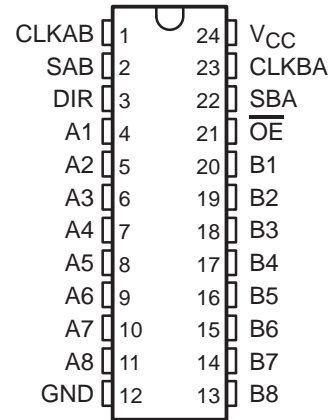

DEVICE	OUTPUT	LOGIC
SN54ALS646, SN74ALS646A, 'AS646	3 state	True
SN54ALS648, SN74ALS648A, SN74AS648	3 state	Inverting

## description

These devices consist of bus-transceiver circuits with 3-state or open-collector outputs, D-type flip-flops, and control circuitry arranged for multiplexed transmission of data directly from the data bus or from the internal storage registers. Data on the A or B bus is clocked into the registers on the low-to-high transition of the appropriate clock (CLKAB or CLKBA) input. Figure 1 illustrates the four fundamental bus-management functions that can be performed with the octal bus transceivers and registers.

Output-enable ( $\overline{OE}$ ) and direction-control (DIR) inputs control the transceiver functions. In the transceiver mode, data present at the high-impedance port may be stored in either or both registers.

The select-control (SAB and SBA) inputs can multiplex stored and real-time (transparent mode) data. The circuitry used for select control eliminates the typical decoding glitch that occurs in a multiplexer during the transition between stored and real-time data. DIR determines which bus receives data when  $\overline{OE}$  is low. In the isolation mode ( $\overline{OE}$  high), A data may be stored in one register and/or B data may be stored in the other register.

When an output function is disabled, the input function is still enabled and can be used to store and transmit data. Only one of the two buses, A or B, may be driven at a time.

The -1 version of the SN74ALS646A is identical to the standard version, except that the recommended maximum  $I_{OL}$  in the -1 version is increased to 48 mA. There are no -1 versions of the SN54ALS646, SN54ALS648, or SN74ALS648A.

The SN54ALS646, SN54ALS648, and SN54AS646 are characterized for operation over the full military temperature range of  $-55^{\circ}\text{C}$  to  $125^{\circ}\text{C}$ . The SN74ALS646A, SN74ALS648A, SN74AS646, and SN74AS648 are characterized for operation from  $0^{\circ}\text{C}$  to  $70^{\circ}\text{C}$ .

SN54ALS646, SN54ALS648, SN54AS646 . . . FK PACKAGE  
(TOP VIEW)

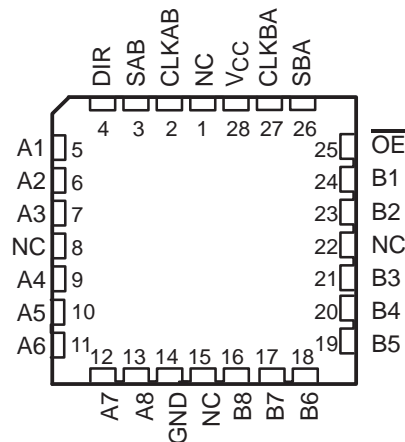

NC – No internal connection

SN54ALS646, SN54ALS648, SN54AS646  
 SN74ALS646A, SN74ALS648A, SN74AS646, SN74AS648  
**OCTAL BUS TRANSCEIVERS AND REGISTERS WITH 3-STATE OUTPUTS**

SDAS039F – DECEMBER 1983 – REVISED JANUARY 1995

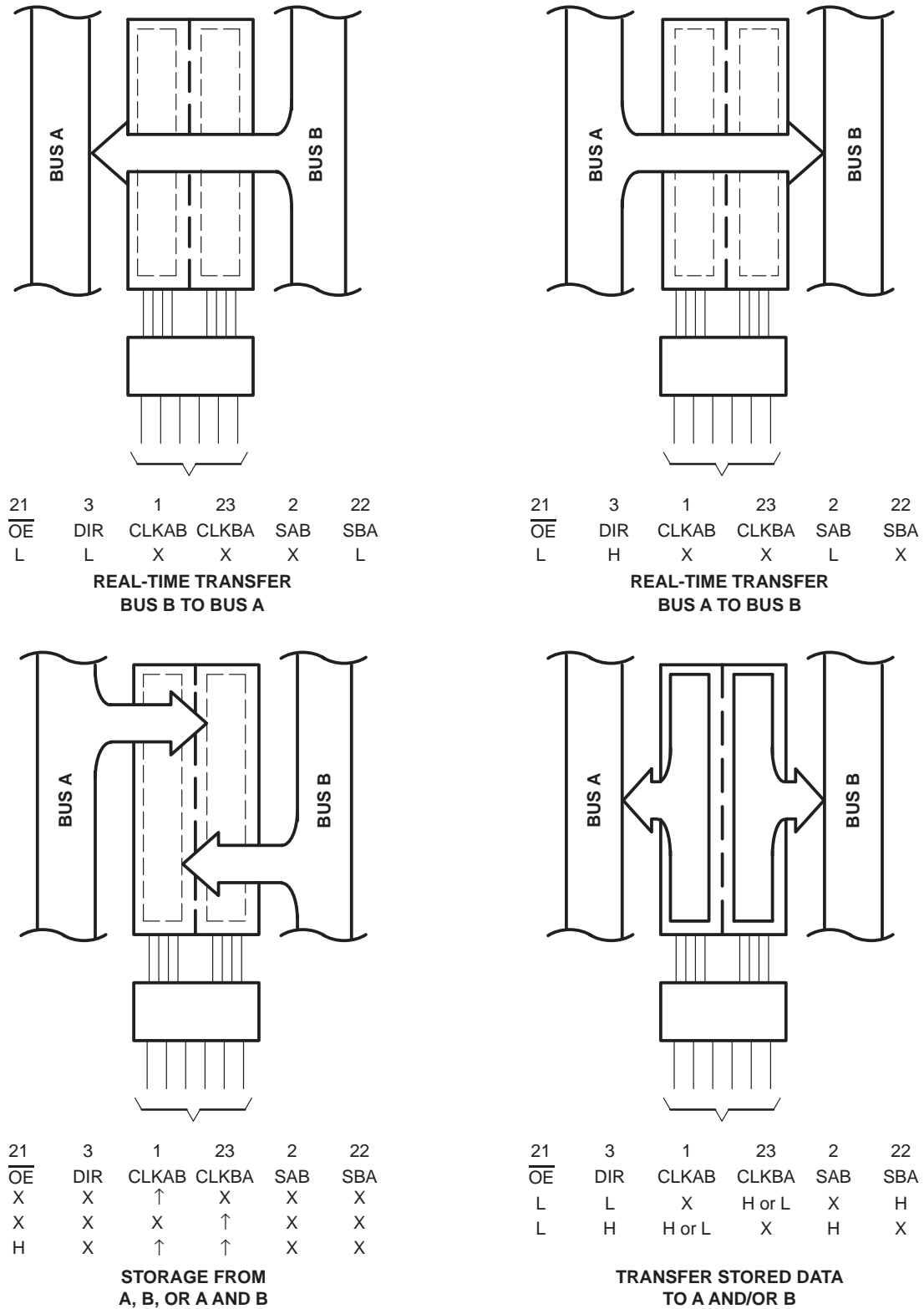

**Figure 1. Bus-Management Functions**

Pin numbers shown are for the DW, JT, and NT packages.

**SN54ALS646, SN54ALS648, SN54AS646**  
**SN74ALS646A, SN74ALS648A, SN74AS646, SN74AS648**  
**OCTAL BUS TRANSCEIVERS AND REGISTERS WITH 3-STATE OUTPUTS**  
SDAS039F – DECEMBER 1983 – REVISED JANUARY 1995

**Function Tables**

**SN54ALS646, SN54AS646, SN74ALS646A, SN74AS646**

INPUTS						DATA I/O		OPERATION OR FUNCTION
$\overline{OE}$	DIR	CLKAB	CLKBA	SAB	SBA	A1–A8	B1–B8	
X	X	↑	X	X	X	Input	Unspecified <sup>†</sup>	Store A, B unspecified <sup>†</sup>
X	X	X	↑	X	X	Unspecified <sup>†</sup>	Input	Store B, A unspecified <sup>†</sup>
H	X	↑	↑	X	X	Input	Input	Store A and B data
H	X	H or L	H or L	X	X	Input disabled	Input disabled	Isolation, hold storage
L	L	X	X	X	L	Output	Input	Real-time B data to A bus
L	L	X	H or L	X	H	Output	Input	Stored B data to A bus
L	H	X	X	L	X	Input	Output	Real-time A data to B bus
L	H	H or L	X	H	X	Input	Output	Stored A data to B bus

<sup>†</sup> The data output functions can be enabled or disabled by various signals at  $\overline{OE}$  and DIR. Data input functions are always enabled; i.e., data at the bus terminals is stored on every low-to-high transition of the clock inputs.

**SN54ALS648, SN74ALS648A, SN74AS648**

INPUTS						DATA I/O		OPERATION OR FUNCTION
$\overline{OE}$	DIR	CLKAB	CLKBA	SAB	SBA	A1–A8	B1–B8	
X	X	↑	X	X	X	Input	Unspecified <sup>†</sup>	Store A, B unspecified <sup>†</sup>
X	X	X	↑	X	X	Unspecified <sup>†</sup>	Input	Store B, A unspecified <sup>†</sup>
H	X	↑	↑	X	X	Input	Input	Store A and B data
H	X	H or L	H or L	X	X	Input disabled	Input disabled	Isolation, hold storage
L	L	X	X	X	L	Output	Input	Real-time $\overline{B}$ data to A bus
L	L	X	H or L	X	H	Output	Input	Stored $\overline{B}$ data to A bus
L	H	X	X	L	X	Input	Output	Real-time $\overline{A}$ data to B bus
L	H	H or L	X	H	X	Input	Output	Stored $\overline{A}$ data to B bus

<sup>†</sup> The data output functions can be enabled or disabled by various signals at  $\overline{OE}$  and DIR. Data input functions are always enabled; i.e., data at the bus terminals is stored on every low-to-high transition of the clock inputs.

**SN54ALS646, SN54ALS648, SN54AS646  
 SN74ALS646A, SN74ALS648A, SN74AS646, SN74AS648  
 OCTAL BUS TRANSCEIVERS AND REGISTERS WITH 3-STATE OUTPUTS**

SDAS039F – DECEMBER 1983 – REVISED JANUARY 1995

**logic symbols†**

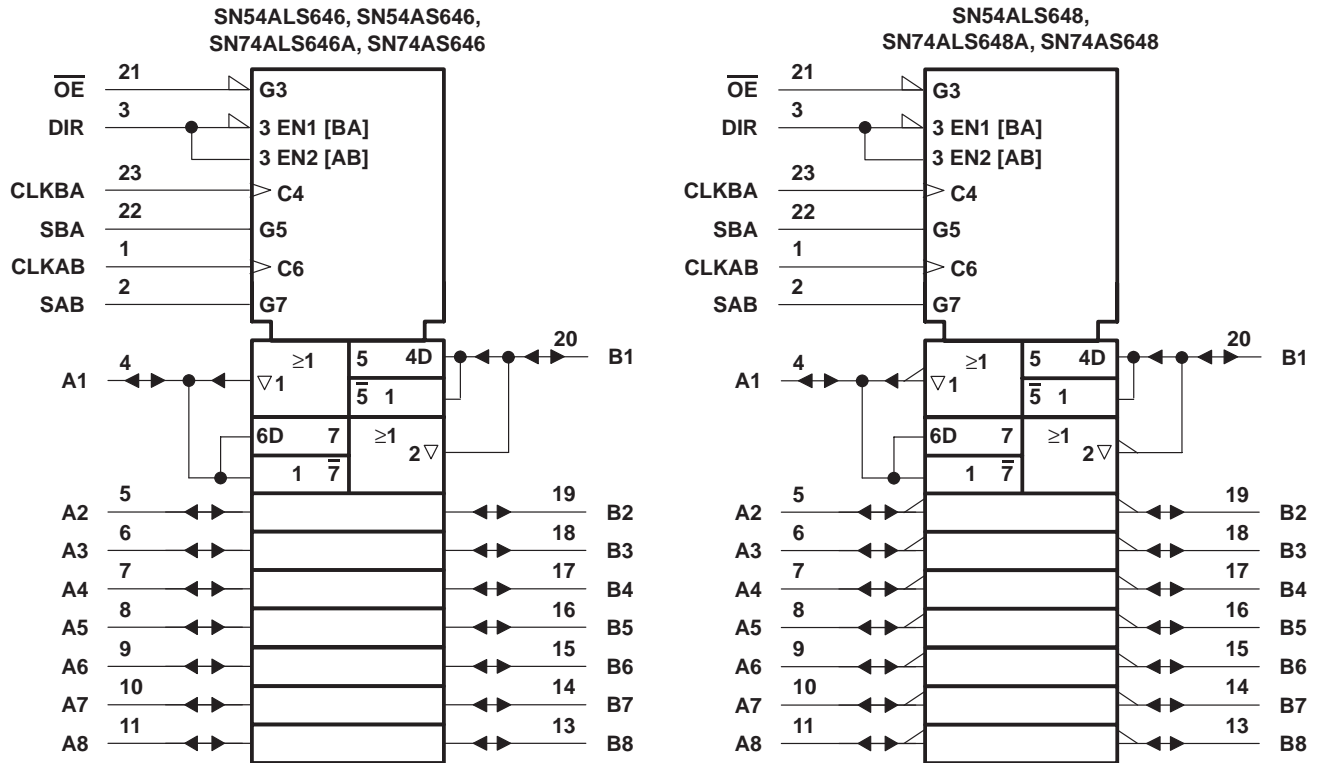

† These symbols are in accordance with ANSI/IEEE Std 91-1984 and IEC Publication 617-12. Pin numbers shown are for the DW, JT, and NT packages.

SN54ALS646, SN54ALS648, SN54AS646  
 SN74ALS646A, SN74ALS648A, SN74AS646, SN74AS648  
 OCTAL BUS TRANSCEIVERS AND REGISTERS WITH 3-STATE OUTPUTS  
 SDAS039F – DECEMBER 1983 – REVISED JANUARY 1995

logic diagrams (positive logic)

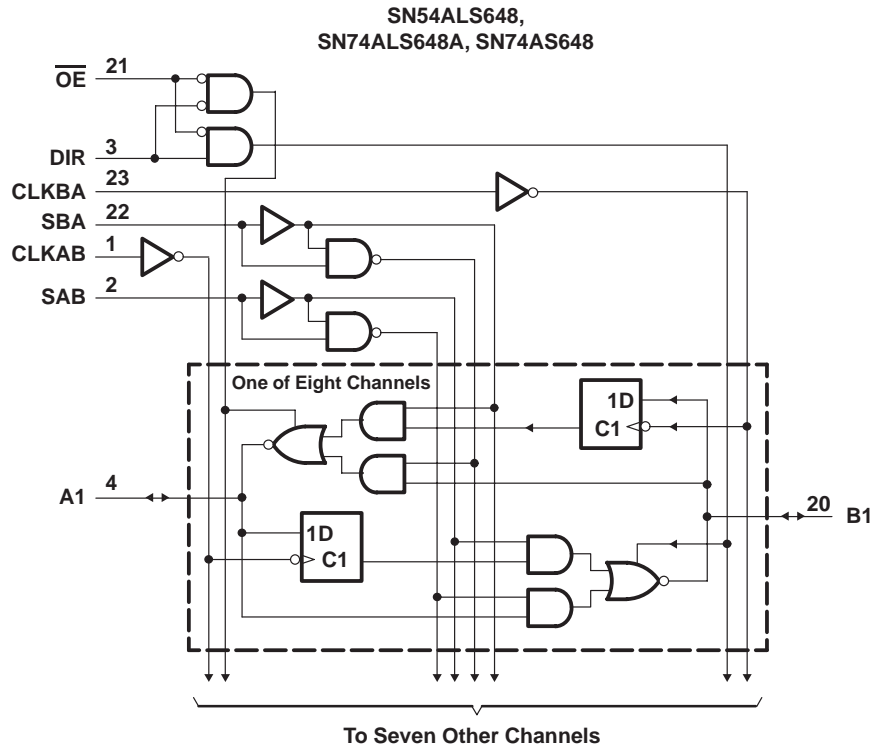
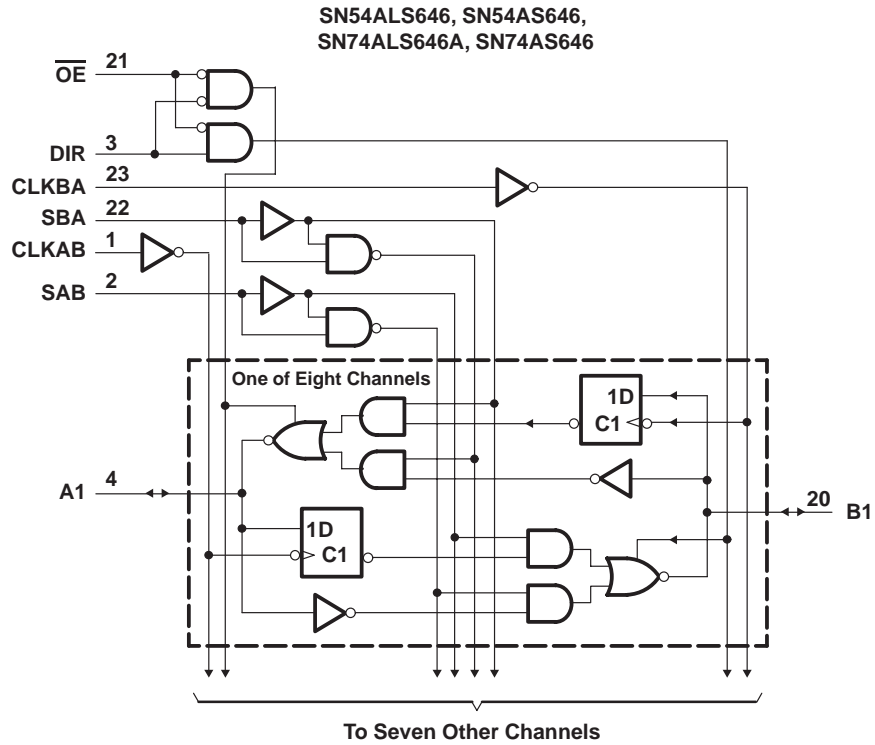

Pin numbers shown are for the DW, JT, and NT packages.



**SN54ALS646, SN54ALS648, SN54AS646**  
**SN74ALS646A, SN74ALS648A, SN74AS646, SN74AS648**  
**OCTAL BUS TRANSCEIVERS AND REGISTERS WITH 3-STATE OUTPUTS**

SDAS039F – DECEMBER 1983 – REVISED JANUARY 1995

**electrical characteristics over recommended operating free-air temperature range (unless otherwise noted)**

PARAMETER		TEST CONDITIONS	SN54ALS646		SN74ALS646A		UNIT	
			MIN	TYP†	MAX	MIN		TYP†
V <sub>IK</sub>		V <sub>CC</sub> = 4.5 V, I <sub>I</sub> = -18 mA			-1.2		V	
V <sub>OH</sub>		V <sub>CC</sub> = 4.5 V to 5.5 V, I <sub>OH</sub> = -0.4 mA	V <sub>CC</sub> -2		V <sub>CC</sub> -2		V	
		V <sub>CC</sub> = 4.5 V	I <sub>OH</sub> = -3 mA	2.4	3.2	2.4		3.2
			I <sub>OH</sub> = -12 mA	2				
V <sub>OL</sub>		V <sub>CC</sub> = 4.5 V	I <sub>OL</sub> = -15 mA			2	V	
			I <sub>OL</sub> = 12 mA	0.25	0.4	0.25		0.4
			I <sub>OL</sub> = 24 mA			0.35		0.5
I <sub>I</sub>		V <sub>CC</sub> = 5.5 V	I <sub>OL</sub> = 48 mA‡			0.35	0.5	
			Control inputs	V <sub>I</sub> = 7 V			0.1	0.1
			A or B ports	V <sub>I</sub> = 5.5 V			0.1	0.1
I <sub>IH</sub>		V <sub>CC</sub> = 5.5 V, V <sub>I</sub> = 2.7 V			20	20	μA	
			Control inputs			20		20
I <sub>IL</sub>		V <sub>CC</sub> = 5.5 V, V <sub>I</sub> = 0.4 V			-0.2	-0.2	mA	
			A or B ports§			-0.2		-0.2
I <sub>O</sub> ¶		V <sub>CC</sub> = 5.5 V, V <sub>O</sub> = 2.25 V	-20	-112	-30	-112	mA	
I <sub>CC</sub>		V <sub>CC</sub> = 5.5 V	Outputs high	47	76	47	76	mA
			Outputs low	55	88	55	88	
			Outputs disabled	55	88	55	88	

† All typical values are at V<sub>CC</sub> = 5 V, T<sub>A</sub> = 25°C.

‡ Applies only to the -1 version and only if V<sub>CC</sub> is maintained between 4.75 V and 5.25 V.

§ For I/O ports, the parameters I<sub>IH</sub> and I<sub>IL</sub> include the off-state output current.

¶ The output conditions have been chosen to produce a current that closely approximates one half of the true short-circuit output current, I<sub>OS</sub>.

SN54ALS646, SN54ALS648, SN54AS646  
 SN74ALS646A, SN74ALS648A, SN74AS646, SN74AS648  
 OCTAL BUS TRANSCEIVERS AND REGISTERS WITH 3-STATE OUTPUTS

SDAS039F – DECEMBER 1983 – REVISED JANUARY 1995

switching characteristics (see Figure 2)

PARAMETER	FROM (INPUT)	TO (OUTPUT)	V <sub>CC</sub> = 4.5 V to 5.5 V, C <sub>L</sub> = 50 pF, R <sub>1</sub> = 500 Ω, R <sub>2</sub> = 500 Ω, T <sub>A</sub> = MIN to MAX†				UNIT
			SN54ALS646		SN74ALS646A		
			MIN	MAX	MIN	MAX	
f <sub>max</sub>			35		40	MHz	
t <sub>PLH</sub>	CLKBA or CLKAB	A or B	10	35	7	30	ns
t <sub>PHL</sub>			5	20	5	17	
t <sub>PLH</sub>	A or B	B or A	5	22	3	20	ns
t <sub>PHL</sub>			3	15	3	12	
t <sub>PLH</sub>	SBA or SAB‡ (stored data low)	A or B	10	40	7	35	ns
t <sub>PHL</sub>			5	23	5	20	
t <sub>PLH</sub>	SBA or SAB‡ (stored data high)	A or B	8	30	6	25	ns
t <sub>PHL</sub>			5	24	5	20	
t <sub>PZH</sub>	$\overline{OE}$	A or B	3	20	2	17	ns
t <sub>PZL</sub>			5	22	4	20	
t <sub>PHZ</sub>	$\overline{OE}$	A or B	1	12	1	10	ns
t <sub>PLZ</sub>			1	20	2	16	
t <sub>PZH</sub>	DIR	A or B	5	38	3	30	ns
t <sub>PZL</sub>			5	30	4	25	
t <sub>PHZ</sub>	DIR	A or B	1	12	1	10	ns
t <sub>PLZ</sub>			2	21	2	16	

† For conditions shown MIN or MAX, use the appropriate value specified under recommended operating conditions.

‡ These parameters are measured with the internal output state of the storage register opposite that of the bus input.

**SN54ALS646, SN54ALS648, SN54AS646  
SN74ALS646A, SN74ALS648A, SN74AS646, SN74AS648  
OCTAL BUS TRANSCEIVERS AND REGISTERS WITH 3-STATE OUTPUTS**

SDAS039F – DECEMBER 1983 – REVISED JANUARY 1995

**absolute maximum ratings over operating free-air temperature range (unless otherwise noted)†**

Supply voltage, $V_{CC}$ .....	7 V
Input voltage, $V_I$ : Control inputs .....	7 V
I/O ports .....	5.5 V
Operating free-air temperature range, $T_A$ : SN54ALS648 .....	–55°C to 125°C
SN74ALS648A .....	0°C to 70°C
Storage temperature range .....	–65°C to 150°C

† Stresses beyond those listed under “absolute maximum ratings” may cause permanent damage to the device. These are stress ratings only, and functional operation of the device at these or any other conditions beyond those indicated under “recommended operating conditions” is not implied. Exposure to absolute-maximum-rated conditions for extended periods may affect device reliability.

**recommended operating conditions**

		SN54ALS648			SN74ALS648A			UNIT
		MIN	NOM	MAX	MIN	NOM	MAX	
$V_{CC}$	Supply voltage	4.5	5	5.5	4.5	5	5.5	V
$V_{IH}$	High-level input voltage	2			2			V
$V_{IL}$	Low-level input voltage			0.7			0.8	V
$I_{OH}$	High-level output current			–12			–15	mA
$I_{OL}$	Low-level output current			12			24	mA
$f_{clock}$	Clock frequency	0		35	0		40	MHz
$t_w$	Pulse duration, CLKBA or CLKAB high or low	14.5			12.5			ns
$t_{su}$	Setup time, A before CLKAB↑ or B before CLKBA↑	15			10			ns
$t_h$	Hold time, A after CLKAB↑ or B after CLKBA↑	0			0			ns
$T_A$	Operating free-air temperature	–55		125	0		70	°C



**SN54ALS646, SN54ALS648, SN54AS646  
SN74ALS646A, SN74ALS648A, SN74AS646, SN74AS648  
OCTAL BUS TRANSCEIVERS AND REGISTERS WITH 3-STATE OUTPUTS**

SDAS039F – DECEMBER 1983 – REVISED JANUARY 1995

**electrical characteristics over recommended operating free-air temperature range (unless otherwise noted)**

PARAMETER		TEST CONDITIONS	SN54ALS648		SN74ALS648A		UNIT		
			MIN	TYP†	MAX	MIN		TYP†	MAX
V <sub>IK</sub>		V <sub>CC</sub> = 4.5 V, I <sub>I</sub> = -18 mA			-1.2			V	
V <sub>OH</sub>		V <sub>CC</sub> = 4.5 V to 5.5 V, I <sub>OH</sub> = -0.4 mA	V <sub>CC</sub> -2		V <sub>CC</sub> -2		V		
		V <sub>CC</sub> = 4.5 V	I <sub>OH</sub> = -3 mA	2.4	3.2	2.4		3.2	
			I <sub>OH</sub> = -12 mA	2					
V <sub>OL</sub>		V <sub>CC</sub> = 4.5 V	I <sub>OL</sub> = 12 mA	0.25	0.4	0.25	0.4	V	
			I <sub>OL</sub> = 24 mA			0.35	0.5		
I <sub>I</sub>	Control inputs	V <sub>CC</sub> = 5.5 V	V <sub>I</sub> = 7 V			0.1	0.1	mA	
	A or B ports		V <sub>I</sub> = 5.5 V			0.1	0.1		
I <sub>IH</sub>	Control inputs	V <sub>CC</sub> = 5.5 V,	V <sub>I</sub> = 2.7 V			20	20	μA	
	A or B ports‡					20	20		
I <sub>IL</sub>	Control inputs	V <sub>CC</sub> = 5.5 V,	V <sub>I</sub> = 0.4 V			-0.2	-0.2	mA	
	A or B ports‡					-0.2	-0.2		
I <sub>O</sub> §		V <sub>CC</sub> = 5.5 V,	V <sub>O</sub> = 2.25 V		-20	-112	-30	-112	mA
I <sub>CC</sub>		V <sub>CC</sub> = 5.5 V	Outputs high		47	76	47	76	mA
			Outputs low		57	88	57	88	
			Outputs disabled		57	88	57	88	

† All typical values are at V<sub>CC</sub> = 5 V, T<sub>A</sub> = 25°C.

‡ For I/O ports, the parameters I<sub>IH</sub> and I<sub>IL</sub> include the off-state output current.

§ The output conditions have been chosen to produce a current that closely approximates one half of the true short-circuit output current, I<sub>OS</sub>.

**SN54ALS646, SN54ALS648, SN54AS646  
SN74ALS646A, SN74ALS648A, SN74AS646, SN74AS648  
OCTAL BUS TRANSCEIVERS AND REGISTERS WITH 3-STATE OUTPUTS**

SDAS039F – DECEMBER 1983 – REVISED JANUARY 1995

**switching characteristics (see Figure 2)**

PARAMETER	FROM (INPUT)	TO (OUTPUT)	V <sub>CC</sub> = 4.5 V to 5.5 V, C <sub>L</sub> = 50 pF, R <sub>1</sub> = 500 Ω, R <sub>2</sub> = 500 Ω, T <sub>A</sub> = MIN to MAX†				UNIT
			SN54ALS648		SN74ALS648A		
			MIN	MAX	MIN	MAX	
f <sub>max</sub>			35		40		MHz
t <sub>PLH</sub>	CLKBA or CLKAB	A or B	8	39	7	33	ns
t <sub>PHL</sub>			5	23	5	20	
t <sub>PLH</sub>	A or B	B or A	3	20	2	17	ns
t <sub>PHL</sub>			2	12	2	10	
t <sub>PLH</sub>	SBA or SAB‡ (stored data low)	A or B	5	44	5	39	ns
t <sub>PHL</sub>			4	26	4	22	
t <sub>PLH</sub>	SBA or SAB‡ (stored data high)	A or B	6	30	6	25	ns
t <sub>PHL</sub>			6	25	6	21	
t <sub>PZH</sub>	$\overline{OE}$	A or B	4	25	2	22	ns
t <sub>PZL</sub>			4	25	4	22	
t <sub>PHZ</sub>	$\overline{OE}$	A or B	1	12	1	10	ns
t <sub>PLZ</sub>			2	21	2	15	
t <sub>PZH</sub>	DIR	A or B	4	35	2	27	ns
t <sub>PZL</sub>			3	25	3	19	
t <sub>PHZ</sub>	DIR	A or B	1	17	1	14	ns
t <sub>PLZ</sub>			2	22	2	15	

† For conditions shown MIN or MAX, use the appropriate value specified under recommended operating conditions.

‡ These parameters are measured with the internal output state of the storage register opposite that of the bus input.



**SN54ALS646, SN54ALS648, SN54AS646**  
**SN74ALS646A, SN74ALS648A, SN74AS646, SN74AS648**  
**OCTAL BUS TRANSCEIVERS AND REGISTERS WITH 3-STATE OUTPUTS**

SDAS039F – DECEMBER 1983 – REVISED JANUARY 1995

**electrical characteristics over recommended operating free-air temperature range (unless otherwise noted)**

PARAMETER	TEST CONDITIONS	SN54AS646		SN74AS646		UNIT		
		MIN	TYP†	MAX	MIN		TYP†	MAX
$V_{IK}$	$V_{CC} = 4.5\text{ V}$ , $I_I = -18\text{ mA}$			-1.2		-1.2	V	
$V_{OH}$	$V_{CC} = 4.5\text{ V to }5.5\text{ V}$ , $I_{OH} = -2\text{ mA}$	$V_{CC}-2$		$V_{CC}-2$		V		
	$V_{CC} = 4.5\text{ V}$	$I_{OH} = -3\text{ mA}$	2.4	3.2	2.4		3.2	
		$I_{OH} = -12\text{ mA}$	2					
$V_{OL}$	$V_{CC} = 4.5\text{ V}$	$I_{OL} = 32\text{ mA}$	0.25	0.5			V	
		$I_{OL} = 48\text{ mA}$			0.35	0.5		
$I_I$	Control inputs	$V_{CC} = 5.5\text{ V}$ ,	$V_I = 7\text{ V}$		0.1		mA	
	A or B ports	$V_{CC} = 5.5\text{ V}$ ,	$V_I = 5.5\text{ V}$		0.1			
$I_{IH}$	Control inputs	$V_{CC} = 5.5\text{ V}$ ,	$V_I = 2.7\text{ V}$		20		$\mu\text{A}$	
	A or B ports‡				70			
$I_{IL}$	Control input	$V_{CC} = 5.5\text{ V}$ ,	$V_I = 0.4\text{ V}$		-0.5		mA	
	A or B ports‡				-0.75			
$I_{OS}§$	$V_{CC} = 5.5\text{ V}$ ,	$V_O = 2.25\text{ V}$		-30	-112	-30	-112	mA
$I_{CC}$	$V_{CC} = 5.5\text{ V}$	Outputs high	120	195	120	195	mA	
		Outputs low	130	211	130	211		
		Outputs disabled	130	211	130	211		

† All typical values are at  $V_{CC} = 5\text{ V}$ ,  $T_A = 25\text{ }^\circ\text{C}$ .

‡ For I/O ports, the parameters  $I_{IH}$  and  $I_{IL}$  include the off-state output current.

§ The output conditions have been chosen to produce a current that closely approximates one half of the true short-circuit output current,  $I_{OS}$ .

SN54ALS646, SN54ALS648, SN54AS646  
 SN74ALS646A, SN74ALS648A, SN74AS646, SN74AS648  
 OCTAL BUS TRANSCEIVERS AND REGISTERS WITH 3-STATE OUTPUTS

SDAS039F – DECEMBER 1983 – REVISED JANUARY 1995

switching characteristics (see Figure 2)

PARAMETER	FROM (INPUT)	TO (OUTPUT)	V <sub>CC</sub> = 4.5 V to 5.5 V, C <sub>L</sub> = 50 pF, R <sub>1</sub> = 500 Ω, R <sub>2</sub> = 500 Ω, T <sub>A</sub> = MIN to MAX†				UNIT
			SN54AS646		SN74AS646		
			MIN	MAX	MIN	MAX	
f <sub>max</sub> *			75		90	MHz	
t <sub>PLH</sub>	CLKBA or CLKAB	A or B	2	9.5	2	8.5	ns
t <sub>PHL</sub>			2	10	2	9	
t <sub>PLH</sub>	A or B	B or A	2	11.5	2	9	ns
t <sub>PHL</sub>			1	8	1	7	
t <sub>PLH</sub>	SBA or SAB‡	A or B	2	13.5	2	11	ns
t <sub>PHL</sub>			2	11	2	9	
t <sub>PZH</sub>	$\overline{OE}$	A or B	2	11	2	9	ns
t <sub>PZL</sub>			3	15	3	14	
t <sub>PHZ</sub>	$\overline{OE}$	A or B	2	11	2	9	ns
t <sub>PLZ</sub>			2	11	2	9	
t <sub>PZH</sub>	DIR	A or B	3	21	3	16	ns
t <sub>PZL</sub>			3	24	3	18	
t <sub>PHZ</sub>	DIR	A or B	2	12	2	10	ns
t <sub>PLZ</sub>			2	12	2	10	

\* On products compliant to MIL-STD-883, Class B, this parameter is based on characterization data but is not production tested.

† For conditions shown MIN or MAX, use the appropriate value specified under recommended operating conditions.

‡ These parameters are measured with the internal output state of the storage register opposite that of the bus input.

**SN54ALS646, SN54ALS648, SN54AS646**  
**SN74ALS646A, SN74ALS648A, SN74AS646, SN74AS648**  
**OCTAL BUS TRANSCEIVERS AND REGISTERS WITH 3-STATE OUTPUTS**

SDAS039F – DECEMBER 1983 – REVISED JANUARY 1995

**absolute maximum ratings over operating free-air temperature range (unless otherwise noted)†**

Supply voltage, $V_{CC}$ .....	7 V
Input voltage, $V_I$ : Control inputs .....	7 V
I/O ports .....	5.5 V
Operating free-air temperature range, $T_A$ : SN74AS648 .....	0°C to 70°C
Storage temperature range .....	–65°C to 150°C

† Stresses beyond those listed under “absolute maximum ratings” may cause permanent damage to the device. These are stress ratings only, and functional operation of the device at these or any other conditions beyond those indicated under “recommended operating conditions” is not implied. Exposure to absolute-maximum-rated conditions for extended periods may affect device reliability.

**recommended operating conditions**

		SN74AS648			UNIT
		MIN	NOM	MAX	
$V_{CC}$	Supply voltage	4.5	5	5.5	V
$V_{IH}$	High-level input voltage	2			V
$V_{IL}$	Low-level input voltage			0.8	V
$I_{OH}$	High-level output current			–15	mA
$I_{OL}$	Low-level output current			48	mA
$f_{clock}$	Clock frequency	0		90	MHz
$t_w$	Pulse duration	CLKBA or CLKAB high	5		ns
		CLKBA or CLKAB low	6		
$t_{su}$	Setup time, A before CLKAB↑ or B before CLKBA↑	6			ns
$t_h$	Hold time, A after CLKAB↑ or B before CLKBA	0			ns
$T_A$	Operating free-air temperature	0		70	°C

**electrical characteristics over recommended operating free-air temperature range (unless otherwise noted)**

PARAMETER		TEST CONDITIONS		SN74AS648			UNIT
				MIN	TYP‡	MAX	
$V_{IK}$		$V_{CC} = 4.5\text{ V}$ ,	$I_I = -18\text{ mA}$	–1.2		V	
$V_{OH}$		$V_{CC} = 4.5\text{ V to } 5.5\text{ V}$ ,	$I_{OH} = -2\text{ mA}$	$V_{CC} - 2$		V	
		$V_{CC} = 4.5\text{ V}$	$I_{OH} = -3\text{ mA}$	2.4	3.2		
			$I_{OH} = -15\text{ mA}$	2			
$V_{OL}$		$V_{CC} = 4.5\text{ V}$ ,	$I_{OL} = 48\text{ mA}$	0.35	0.5	V	
$I_I$	Control inputs	$V_{CC} = 5.5\text{ V}$	$V_I = 7\text{ V}$	0.1		mA	
	A or B ports		$V_I = 5.5\text{ V}$	0.1			
$I_{IH}$	Control inputs	$V_{CC} = 5.5\text{ V}$ ,	$V_I = 2.7\text{ V}$	20		µA	
	A or B ports§			70			
$I_{IL}$	Control input	$V_{CC} = 5.5\text{ V}$ ,	$V_I = 0.4\text{ V}$	–0.5		mA	
	A or B ports§			–0.75			
$I_{O}^{\parallel}$		$V_{CC} = 5.5\text{ V}$ ,	$V_O = 2.25\text{ V}$	–30	–112	mA	
$I_{CC}$		$V_{CC} = 5.5\text{ V}$	Outputs high	110	185	mA	
			Outputs low	120	195		
			Outputs disabled	120	195		

‡ All typical values are at  $V_{CC} = 5\text{ V}$ ,  $T_A = 25\text{ °C}$ .

§ For I/O ports, the parameters  $I_{IH}$  and  $I_{IL}$  include the off-state output current.

¶ The output conditions have been chosen to produce a current that closely approximates one half of the true short-circuit output current,  $I_{OS}$ .



SN54ALS646, SN54ALS648, SN54AS646  
 SN74ALS646A, SN74ALS648A, SN74AS646, SN74AS648  
 OCTAL BUS TRANSCEIVERS AND REGISTERS WITH 3-STATE OUTPUTS

SDAS039F – DECEMBER 1983 – REVISED JANUARY 1995

switching characteristics (see Figure 2)

PARAMETER	FROM (INPUT)	TO (OUTPUT)	V <sub>CC</sub> = 4.5 V to 5.5 V, C <sub>L</sub> = 50 pF, R1 = 500 Ω, R2 = 500 Ω, T <sub>A</sub> = MIN to MAX†		UNIT
			SN74AS648		
			MIN	MAX	
f <sub>max</sub>			90		MHz
t <sub>PLH</sub>	CLKBA or CLKAB	A or B	2	8.5	ns
t <sub>PHL</sub>			2	9	
t <sub>PLH</sub>	A or B	B or A	2	8	ns
t <sub>PHL</sub>			1	7	
t <sub>PLH</sub>	SBA or SAB‡	A or B	2	11	ns
t <sub>PHL</sub>			2	9	
t <sub>PZH</sub>	$\overline{OE}$	A or B	2	9	ns
t <sub>PZL</sub>			3	15	
t <sub>PHZ</sub>	$\overline{OE}$	A or B	2	9	ns
t <sub>PLZ</sub>			2	9	
t <sub>PZH</sub>	DIR	A or B	3	16	ns
t <sub>PZL</sub>			3	18	
t <sub>PHZ</sub>	DIR	A or B	2	10	ns
t <sub>PLZ</sub>			2	10	

† For conditions shown MIN or MAX, use the appropriate value specified under recommended operating conditions.

‡ These parameters are measured with the internal output state of the storage register opposite that of the bus input.



SN54ALS646, SN54ALS648, SN54AS646  
SN74ALS646A, SN74ALS648A, SN74AS646, SN74AS648  
OCTAL BUS TRANSCEIVERS AND REGISTERS WITH 3-STATE OUTPUTS

SDAS039F – DECEMBER 1983 – REVISED JANUARY 1995

**PARAMETER MEASUREMENT INFORMATION**

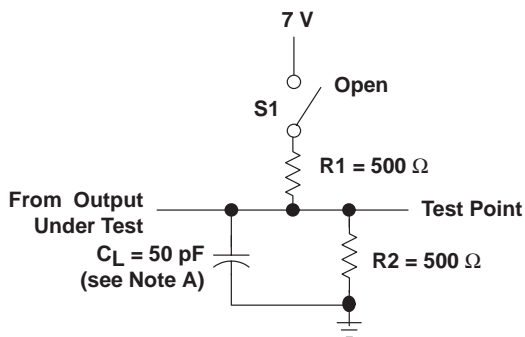

**LOAD CIRCUIT  
FOR 3-STATE OUTPUTS**

**SWITCH POSITION TABLE**

TEST	S1
t <sub>PLH</sub>	Open
t <sub>PHL</sub>	Open
t <sub>PZH</sub>	Open
t <sub>PZL</sub>	Closed
t <sub>PHZ</sub>	Open
t <sub>PLZ</sub>	Closed

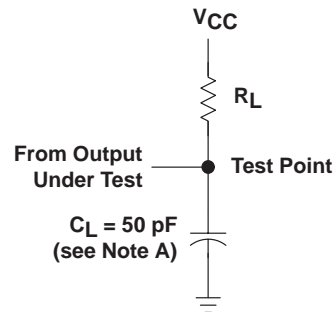

**LOAD CIRCUIT  
FOR OPEN-COLLECTOR OUTPUTS**

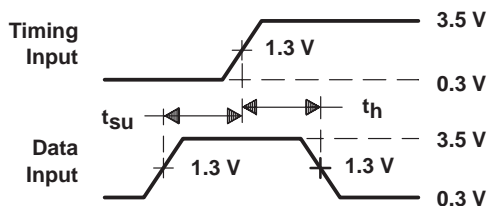

**VOLTAGE WAVEFORMS  
SETUP AND HOLD TIMES**

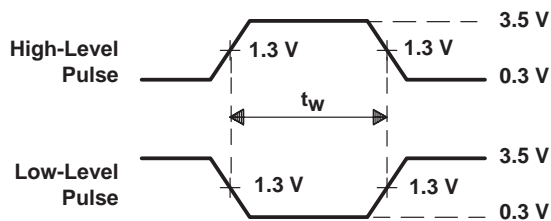

**VOLTAGE WAVEFORMS  
PULSE DURATION**

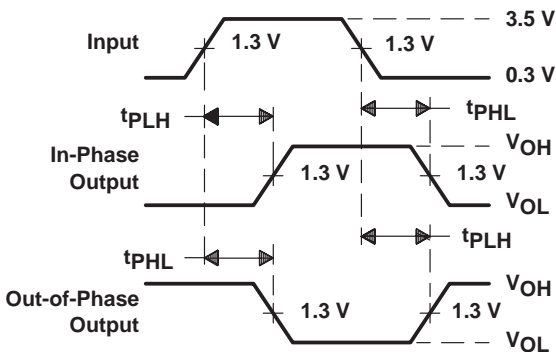

**VOLTAGE WAVEFORMS  
PROPAGATION DELAY TIMES**

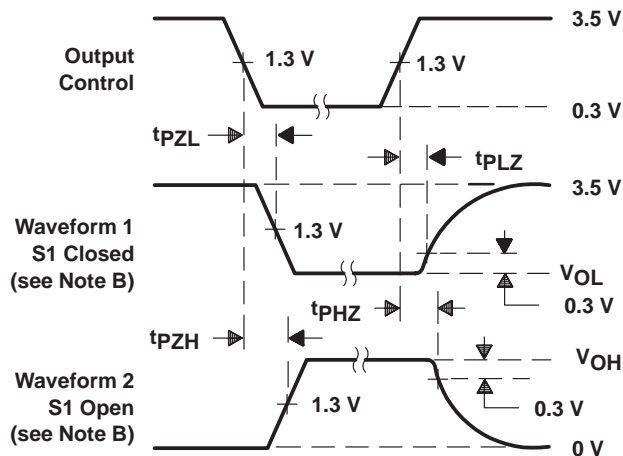

**VOLTAGE WAVEFORMS  
ENABLE AND DISABLE TIMES, 3-STATE OUTPUTS**

- NOTES: A.  $C_L$  includes probe and jig capacitance.  
B. Waveform 1 is for an output with internal conditions such that the output is low except when disabled by the output control. Waveform 2 is for an output with internal conditions such that the output is high except when disabled by the output control.  
C. All input pulses are supplied by generators having the following characteristics:  $PRR \leq 1$  MHz,  $Z_O = 50 \Omega$ ,  $t_r \leq 2$  ns,  $t_f \leq 2$  ns.  
D. The outputs are measured one at a time with one transition per measurement.

**Figure 2. Load Circuits and Voltage Waveforms**

**PACKAGING INFORMATION**

Orderable Device	Status (1)	Package Type	Package Drawing	Pins	Package Qty	Eco Plan (2)	Lead/Ball Finish (6)	MSL Peak Temp (3)	Op Temp (°C)	Device Marking (4/5)	Samples
5962-8759501LA	ACTIVE	CDIP	JT	24	1	TBD	A42	N / A for Pkg Type	-55 to 125	5962-8759501LA SNJ54AS646JT	<a href="#">Samples</a>
5962-8995601LA	ACTIVE	CDIP	JT	24	1	TBD	A42	N / A for Pkg Type	-55 to 125	5962-8995601LA SNJ54ALS646JT	<a href="#">Samples</a>
5962-9052301LA	ACTIVE	CDIP	JT	24	1	TBD	A42	N / A for Pkg Type	-55 to 125	5962-9052301LA SNJ54ALS648JT	<a href="#">Samples</a>
SN74ALS646A-1DWR	OBSOLETE	SOIC	DW	24		TBD	Call TI	Call TI	0 to 70		
SN74ALS646A-1DWR4	OBSOLETE	SOIC	DW	24		TBD	Call TI	Call TI	0 to 70		
SN74ALS646A-1DWRG4	OBSOLETE	SOIC	DW	24		TBD	Call TI	Call TI	0 to 70		
SN74ALS646ADW	ACTIVE	SOIC	DW	24	25	Green (RoHS & no Sb/Br)	CU NIPDAU	Level-1-260C-UNLIM	0 to 70	ALS646A	<a href="#">Samples</a>
SN74ALS646ADWE4	ACTIVE	SOIC	DW	24	25	Green (RoHS & no Sb/Br)	CU NIPDAU	Level-1-260C-UNLIM	0 to 70	ALS646A	<a href="#">Samples</a>
SN74ALS646ADWR	ACTIVE	SOIC	DW	24	2000	Green (RoHS & no Sb/Br)	CU NIPDAU	Level-1-260C-UNLIM	0 to 70	ALS646A	<a href="#">Samples</a>
SN74ALS648ADW	ACTIVE	SOIC	DW	24	25	Green (RoHS & no Sb/Br)	CU NIPDAU	Level-1-260C-UNLIM	0 to 70	ALS648A	<a href="#">Samples</a>
SN74AS646DW	ACTIVE	SOIC	DW	24	25	Green (RoHS & no Sb/Br)	CU NIPDAU	Level-1-260C-UNLIM	0 to 70	AS646	<a href="#">Samples</a>
SN74AS648NT3	OBSOLETE	PDIP	NT	24		TBD	Call TI	Call TI	0 to 70		
SNJ54ALS646JT	ACTIVE	CDIP	JT	24	1	TBD	A42	N / A for Pkg Type	-55 to 125	5962-8995601LA SNJ54ALS646JT	<a href="#">Samples</a>
SNJ54ALS646W	OBSOLETE	CFP	W	24		TBD	Call TI	Call TI	-55 to 125		
SNJ54ALS648FK	OBSOLETE	LCCC	FK	24		TBD	Call TI	Call TI	-55 to 125		
SNJ54ALS648JT	ACTIVE	CDIP	JT	24	1	TBD	A42	N / A for Pkg Type	-55 to 125	5962-9052301LA SNJ54ALS648JT	<a href="#">Samples</a>
SNJ54ALS648W	OBSOLETE	CFP	W	24		TBD	Call TI	Call TI	-55 to 125		
SNJ54AS646JT	ACTIVE	CDIP	JT	24	1	TBD	A42	N / A for Pkg Type	-55 to 125	5962-8759501LA SNJ54AS646JT	<a href="#">Samples</a>

(1) The marketing status values are defined as follows:

**ACTIVE:** Product device recommended for new designs.

**LIFEBUY:** TI has announced that the device will be discontinued, and a lifetime-buy period is in effect.

**NRND:** Not recommended for new designs. Device is in production to support existing customers, but TI does not recommend using this part in a new design.

**PREVIEW:** Device has been announced but is not in production. Samples may or may not be available.

**OBSOLETE:** TI has discontinued the production of the device.

(2) Eco Plan - The planned eco-friendly classification: Pb-Free (RoHS), Pb-Free (RoHS Exempt), or Green (RoHS & no Sb/Br) - please check <http://www.ti.com/productcontent> for the latest availability information and additional product content details.

**TBD:** The Pb-Free/Green conversion plan has not been defined.

**Pb-Free (RoHS):** TI's terms "Lead-Free" or "Pb-Free" mean semiconductor products that are compatible with the current RoHS requirements for all 6 substances, including the requirement that lead not exceed 0.1% by weight in homogeneous materials. Where designed to be soldered at high temperatures, TI Pb-Free products are suitable for use in specified lead-free processes.

**Pb-Free (RoHS Exempt):** This component has a RoHS exemption for either 1) lead-based flip-chip solder bumps used between the die and package, or 2) lead-based die adhesive used between the die and leadframe. The component is otherwise considered Pb-Free (RoHS compatible) as defined above.

**Green (RoHS & no Sb/Br):** TI defines "Green" to mean Pb-Free (RoHS compatible), and free of Bromine (Br) and Antimony (Sb) based flame retardants (Br or Sb do not exceed 0.1% by weight in homogeneous material)

(3) MSL, Peak Temp. - The Moisture Sensitivity Level rating according to the JEDEC industry standard classifications, and peak solder temperature.

(4) There may be additional marking, which relates to the logo, the lot trace code information, or the environmental category on the device.

(5) Multiple Device Markings will be inside parentheses. Only one Device Marking contained in parentheses and separated by a "~" will appear on a device. If a line is indented then it is a continuation of the previous line and the two combined represent the entire Device Marking for that device.

(6) Lead/Ball Finish - Orderable Devices may have multiple material finish options. Finish options are separated by a vertical ruled line. Lead/Ball Finish values may wrap to two lines if the finish value exceeds the maximum column width.

**Important Information and Disclaimer:** The information provided on this page represents TI's knowledge and belief as of the date that it is provided. TI bases its knowledge and belief on information provided by third parties, and makes no representation or warranty as to the accuracy of such information. Efforts are underway to better integrate information from third parties. TI has taken and continues to take reasonable steps to provide representative and accurate information but may not have conducted destructive testing or chemical analysis on incoming materials and chemicals. TI and TI suppliers consider certain information to be proprietary, and thus CAS numbers and other limited information may not be available for release.

In no event shall TI's liability arising out of such information exceed the total purchase price of the TI part(s) at issue in this document sold by TI to Customer on an annual basis.

**OTHER QUALIFIED VERSIONS OF SN54ALS646, SN54ALS648, SN54AS646, SN74AS646 :**

● Catalog: [SN74ALS646](#), [SN74ALS648](#), [SN74AS646](#)

● Military: [SN54AS646](#)

NOTE: Qualified Version Definitions:

● Catalog - TI's standard catalog product

- Military - QML certified for Military and Defense Applications

## TAPE AND REEL INFORMATION



### QUADRANT ASSIGNMENTS FOR PIN 1 ORIENTATION IN TAPE



\*All dimensions are nominal

Device	Package Type	Package Drawing	Pins	SPQ	Reel Diameter (mm)	Reel Width W1 (mm)	A0 (mm)	B0 (mm)	K0 (mm)	P1 (mm)	W (mm)	Pin1 Quadrant
SN74ALS646ADWR	SOIC	DW	24	2000	330.0	24.4	10.75	15.7	2.7	12.0	24.0	Q1

TAPE AND REEL BOX DIMENSIONS



\*All dimensions are nominal

Device	Package Type	Package Drawing	Pins	SPQ	Length (mm)	Width (mm)	Height (mm)
SN74ALS646ADWR	SOIC	DW	24	2000	367.0	367.0	45.0

JT (R-GDIP-T\*\*)

CERAMIC DUAL-IN-LINE

24 LEADS SHOWN

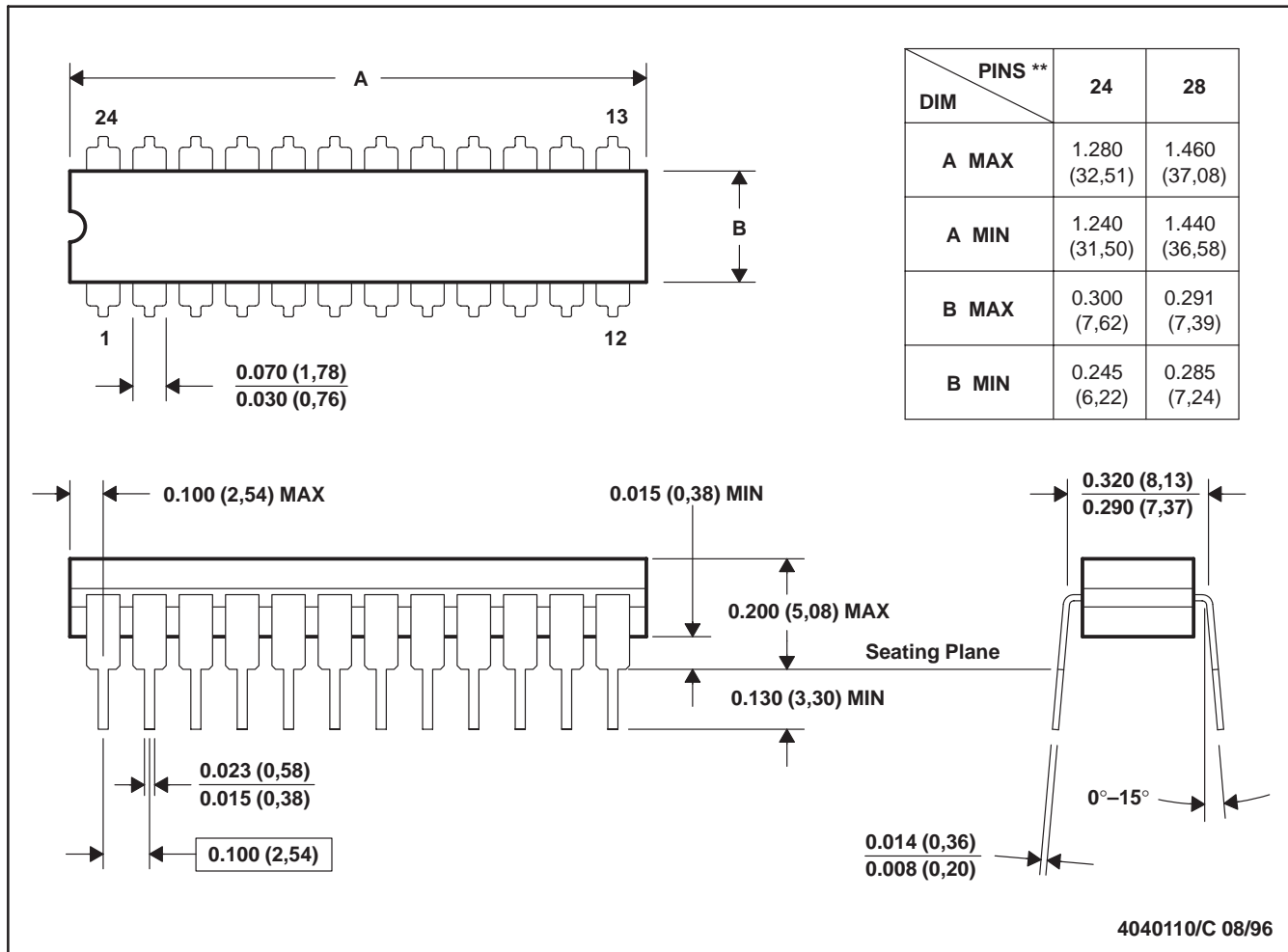

- NOTES: A. All linear dimensions are in inches (millimeters).  
 B. This drawing is subject to change without notice.  
 C. This package can be hermetically sealed with a ceramic lid using glass frit.  
 D. Index point is provided on cap for terminal identification.  
 E. Falls within MIL STD 1835 GDIP3-T24, GDIP4-T28, and JEDEC MO-058 AA, MO-058 AB

W (R-GDFP-F24)

CERAMIC DUAL FLATPACK

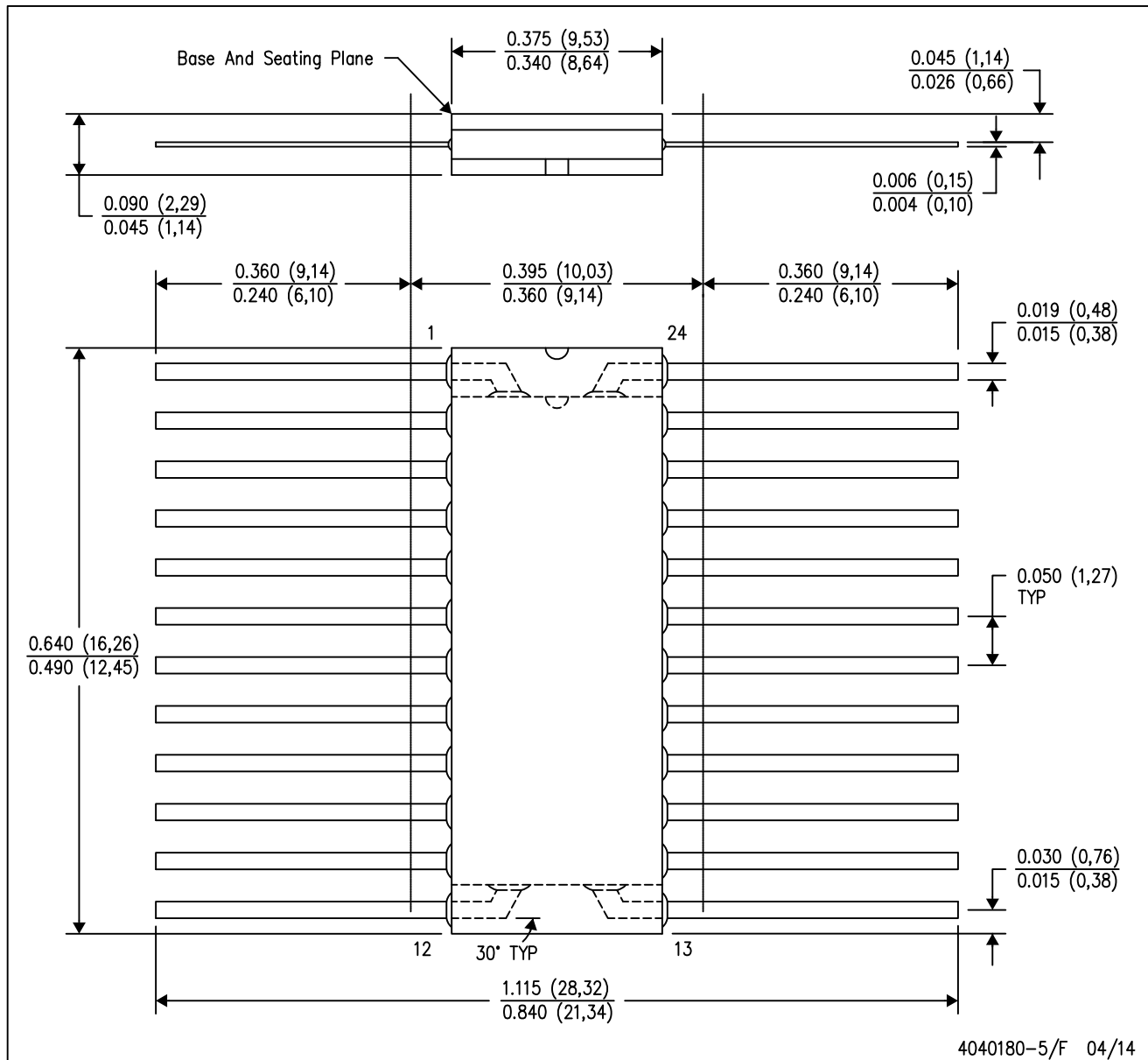



- NOTES:
- A. All linear dimensions are in inches (millimeters).
  - B. This drawing is subject to change without notice.
  - C. This package can be hermetically sealed with a ceramic lid using glass frit.
  - D. Index point is provided on cap for terminal identification only.
  - E. Falls within Mil-Std 1835 GDFP2-F20

# MECHANICAL DATA

NT (R-PDIP-T\*\*) 24 PINS SHOWN

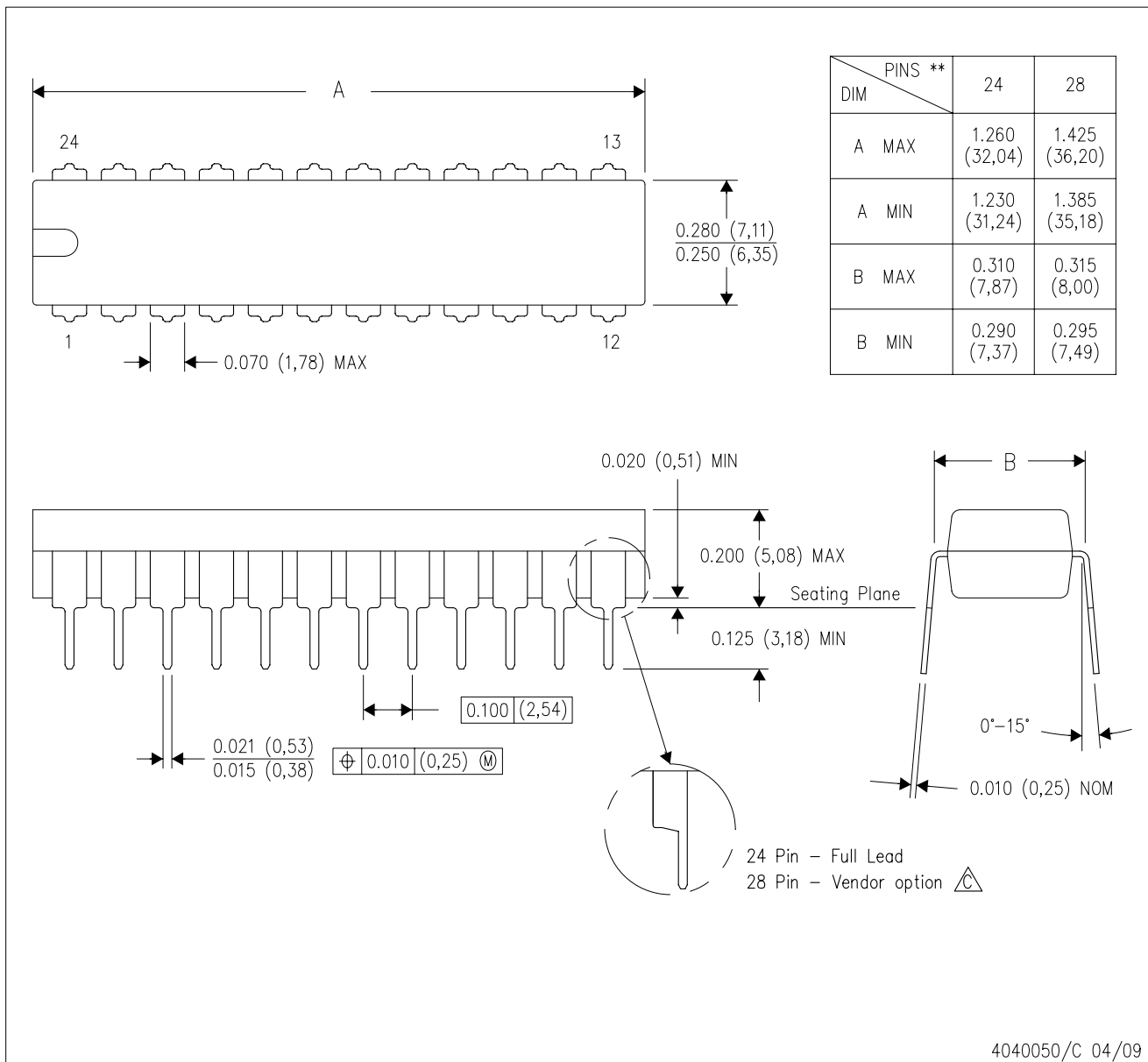
PLASTIC DUAL-IN-LINE PACKAGE



- NOTES:
- A. All linear dimensions are in millimeters. Dimensioning and tolerancing per ASME Y14.5M-1994.
  - B. This drawing is subject to change without notice.
  -  The 28 pin end lead shoulder width is a vendor option, either half or full width.

DW (R-PDSO-G24)

PLASTIC SMALL OUTLINE

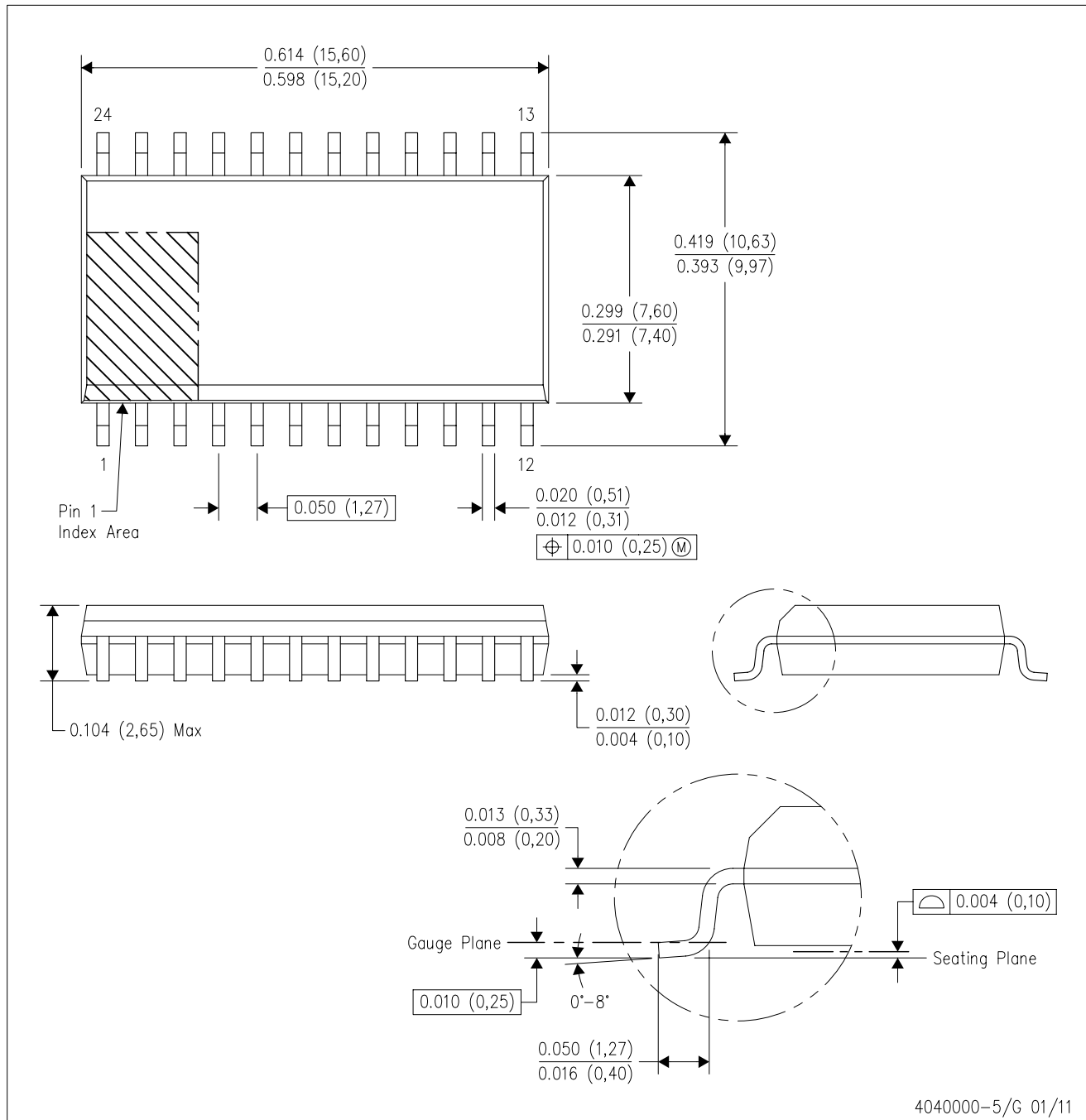

- NOTES:
- A. All linear dimensions are in inches (millimeters). Dimensioning and tolerancing per ASME Y14.5M-1994.
  - B. This drawing is subject to change without notice.
  - C. Body dimensions do not include mold flash or protrusion not to exceed 0.006 (0,15).
  - D. Falls within JEDEC MS-013 variation AD.

## IMPORTANT NOTICE

Texas Instruments Incorporated and its subsidiaries (TI) reserve the right to make corrections, enhancements, improvements and other changes to its semiconductor products and services per JESD46, latest issue, and to discontinue any product or service per JESD48, latest issue. Buyers should obtain the latest relevant information before placing orders and should verify that such information is current and complete. All semiconductor products (also referred to herein as "components") are sold subject to TI's terms and conditions of sale supplied at the time of order acknowledgment.

TI warrants performance of its components to the specifications applicable at the time of sale, in accordance with the warranty in TI's terms and conditions of sale of semiconductor products. Testing and other quality control techniques are used to the extent TI deems necessary to support this warranty. Except where mandated by applicable law, testing of all parameters of each component is not necessarily performed.

TI assumes no liability for applications assistance or the design of Buyers' products. Buyers are responsible for their products and applications using TI components. To minimize the risks associated with Buyers' products and applications, Buyers should provide adequate design and operating safeguards.

TI does not warrant or represent that any license, either express or implied, is granted under any patent right, copyright, mask work right, or other intellectual property right relating to any combination, machine, or process in which TI components or services are used. Information published by TI regarding third-party products or services does not constitute a license to use such products or services or a warranty or endorsement thereof. Use of such information may require a license from a third party under the patents or other intellectual property of the third party, or a license from TI under the patents or other intellectual property of TI.

Reproduction of significant portions of TI information in TI data books or data sheets is permissible only if reproduction is without alteration and is accompanied by all associated warranties, conditions, limitations, and notices. TI is not responsible or liable for such altered documentation. Information of third parties may be subject to additional restrictions.

Resale of TI components or services with statements different from or beyond the parameters stated by TI for that component or service voids all express and any implied warranties for the associated TI component or service and is an unfair and deceptive business practice. TI is not responsible or liable for any such statements.

Buyer acknowledges and agrees that it is solely responsible for compliance with all legal, regulatory and safety-related requirements concerning its products, and any use of TI components in its applications, notwithstanding any applications-related information or support that may be provided by TI. Buyer represents and agrees that it has all the necessary expertise to create and implement safeguards which anticipate dangerous consequences of failures, monitor failures and their consequences, lessen the likelihood of failures that might cause harm and take appropriate remedial actions. Buyer will fully indemnify TI and its representatives against any damages arising out of the use of any TI components in safety-critical applications.

In some cases, TI components may be promoted specifically to facilitate safety-related applications. With such components, TI's goal is to help enable customers to design and create their own end-product solutions that meet applicable functional safety standards and requirements. Nonetheless, such components are subject to these terms.

No TI components are authorized for use in FDA Class III (or similar life-critical medical equipment) unless authorized officers of the parties have executed a special agreement specifically governing such use.

Only those TI components which TI has specifically designated as military grade or "enhanced plastic" are designed and intended for use in military/aerospace applications or environments. Buyer acknowledges and agrees that any military or aerospace use of TI components which have **not** been so designated is solely at the Buyer's risk, and that Buyer is solely responsible for compliance with all legal and regulatory requirements in connection with such use.

TI has specifically designated certain components as meeting ISO/TS16949 requirements, mainly for automotive use. In any case of use of non-designated products, TI will not be responsible for any failure to meet ISO/TS16949.

### Products

Audio	<a href="http://www.ti.com/audio">www.ti.com/audio</a>
Amplifiers	<a href="http://amplifier.ti.com">amplifier.ti.com</a>
Data Converters	<a href="http://dataconverter.ti.com">dataconverter.ti.com</a>
DLP® Products	<a href="http://www.dlp.com">www.dlp.com</a>
DSP	<a href="http://dsp.ti.com">dsp.ti.com</a>
Clocks and Timers	<a href="http://www.ti.com/clocks">www.ti.com/clocks</a>
Interface	<a href="http://interface.ti.com">interface.ti.com</a>
Logic	<a href="http://logic.ti.com">logic.ti.com</a>
Power Mgmt	<a href="http://power.ti.com">power.ti.com</a>
Microcontrollers	<a href="http://microcontroller.ti.com">microcontroller.ti.com</a>
RFID	<a href="http://www.ti-rfid.com">www.ti-rfid.com</a>
OMAP Applications Processors	<a href="http://www.ti.com/omap">www.ti.com/omap</a>
Wireless Connectivity	<a href="http://www.ti.com/wirelessconnectivity">www.ti.com/wirelessconnectivity</a>

### Applications

Automotive and Transportation	<a href="http://www.ti.com/automotive">www.ti.com/automotive</a>
Communications and Telecom	<a href="http://www.ti.com/communications">www.ti.com/communications</a>
Computers and Peripherals	<a href="http://www.ti.com/computers">www.ti.com/computers</a>
Consumer Electronics	<a href="http://www.ti.com/consumer-apps">www.ti.com/consumer-apps</a>
Energy and Lighting	<a href="http://www.ti.com/energy">www.ti.com/energy</a>
Industrial	<a href="http://www.ti.com/industrial">www.ti.com/industrial</a>
Medical	<a href="http://www.ti.com/medical">www.ti.com/medical</a>
Security	<a href="http://www.ti.com/security">www.ti.com/security</a>
Space, Avionics and Defense	<a href="http://www.ti.com/space-avionics-defense">www.ti.com/space-avionics-defense</a>
Video and Imaging	<a href="http://www.ti.com/video">www.ti.com/video</a>

### TI E2E Community

[e2e.ti.com](http://e2e.ti.com)